

MAX16840

LED Driver with Integrated MOSFET for MR16 and Other 12V AC Input Lamps

General Description

The MAX16840 is an LED driver IC for lighting applications. It includes all the necessary features to design low-component-count LED drivers for 12V AC and 24V AC input (e.g., MR16) light bulbs. A proprietary input-current control scheme allows LED lamps based on this device to be compatible with electronic transformers, and dimmable with standard trailing-edge dimmers (where electronic transformers are present).

The IC can be used in buck, boost, and buck-boost topologies and features. It has an integrated 0.2Ω (max), 48V switching MOSFET.

The IC uses constant-frequency average current-mode control. It senses the input current through the voltage at the FB pin, and regulates its average. An input pin (REFI) allows the setting of the input-current level. When the voltage at this pin is set below a certain threshold, the input current is proportional to this voltage, while when that voltage is beyond the threshold, the input current is set at a fixed, predefined level. This nonlinear behavior of REFI allows its use to achieve thermal foldback, by connecting it to an NTC resistor.

The IC also features an internal overvoltage protection on the IN pin to protect the internal switching MOSFET from damage if the LED string is open or if the voltage on the LED string is too high.

The IC has a separate EXT pin that can be used to guarantee that there is a kick-start of current at turn-on for low-input voltages for proper operation with electronic transformers. EXT drives an external npn transistor. Once the UVLO threshold of 5.5V is crossed on IN, EXT is pulled to ground and the external npn transistor is turned off.

The IC is available in a 3mm x 3mm, 10-pin TDFN power package, and is rated over the -40°C to +125°C operating temperature range.

Applications

MR16 and Other 12V AC or DC Input LED Lighting Applications

Benefits and Features

- Cost-Effective Solution for MR16 and Other SSL Applications
 - Proprietary Input Current-Control Scheme to Achieve Electronic Transformer Compatibility and Dimmability
 - Buck, Boost, SEPIC, and Buck-Boost Topologies
 - Analog Dimming
- Minimal Component Count Saves Cost and Space
 - Integrated 0.2Ω (max) 48V Switching MOSFET
- Protection Features and Wide Operating Temperature Range Improves Reliability
 - Thermal-Foldback Protection
 - Output Overvoltage Protection
 - Internal Overtemperature Protection
 - Available in a 10-Pin Thermally Enhanced TDFN Package
 - Operation Over -40°C to +125°C Temperature Range

Ordering Information

PART	TEMP RANGE	PIN-PACKAGE
MAX16840ATB+	-40°C to +125°C	10 TDFN-EP*

+Denotes a lead(Pb)-free/RoHS-compliant package.

*EP = Exposed pad.

Typical Operating Circuit

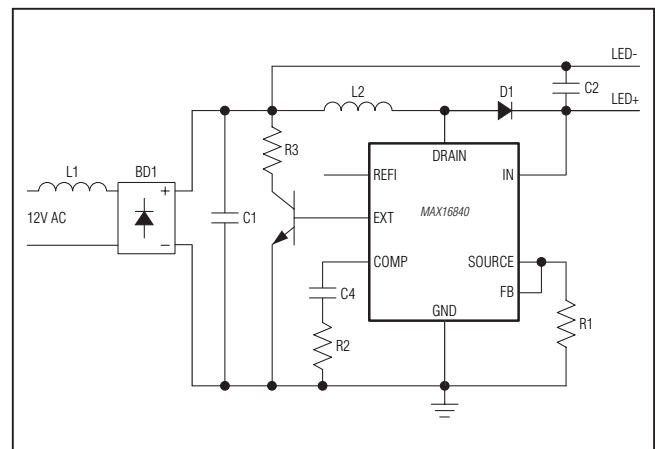

Absolute Maximum Ratings

IN, DRAIN to GND..... -0.3V, +52V
 EXT, COMP, REFI to GND..... -0.3V, +6.0V
 FB, SOURCE to GND..... -0.3V, +1.5V
 Maximum RMS Current, FB, SOURCE to GND..... 0.8A
 Maximum RMS Current Through DRAIN and SOURCE ±2A
 Continuous Power Dissipation (T_A = +70°C)
 TDFN (derate 24.4mW/°C above +70°C)..... 1951mW

Any Pin to Any Pin ESD Rating ±2kV (HBM)
 Operating Temperature Range..... -40°C to +125°C
 Maximum Junction Temperature..... +150°C
 Storage Temperature Range..... -65°C to +150°C
 Lead Temperature (soldering, 10s) +300°C
 Soldering Temperature (reflow) +260°C

Package Thermal Characteristics (Note 1)

TDFN

Junction-to-Ambient Thermal Resistance (θ_{JA}) 41°C/W
 Junction-to-Case Thermal Resistance (θ_{JC}) 9°C/W

Note 1: Package thermal resistances were obtained using the method described in JEDEC specification JESD51-7, using a four-layer board. For detailed information on package thermal considerations, refer to www.maximintegrated.com/thermal-tutorial.

Stresses beyond those listed under "Absolute Maximum Ratings" may cause permanent damage to the device. These are stress ratings only, and functional operation of the device at these or any other conditions beyond those indicated in the operational sections of the specifications is not implied. Exposure to absolute maximum rating conditions for extended periods may affect device reliability.

Electrical Characteristics

(V_{IN} = 12V; V_{EXT} = V_{SOURCE} = V_{FB} = V_{GND} = 0V; COMP, REFI, and DRAIN = open; T_A = T_J = -40°C to +125°C, unless otherwise noted. Typical values are at T_A = +25°C.) (Note 2)

PARAMETER	SYMBOL	CONDITIONS	MIN	TYP	MAX	UNITS
Operating Voltage Range	V _{IN}		6.5		48	V
IN Supply Current	I _{IN}	When MOSFET fully on		1	2	mA
		When MOSFET switching, V _{COMP} = 2V, drain to 5V through 50Ω		1.5	3	
Undervoltage Lockout	UVLO _{IN}	IN rising	5	5.6	6.1	V
UVLO Hysteresis				200		mV
Overshoot Protection on IN	VOVP	IN rising	43.6	46	48	V
OVP Hysteresis				1.2		V
Switching Frequency			270	300	330	kHz
Ramp P-P Voltage				2		V
FB Average Voltage		T _A = +25°C	196	200	204	mV
		-40°C ≤ T _A ≤ +125°C	190		210	
Transconductance	g _m			550		μS
No-Load Gain	A			75		dB
COMP Sink Current	I _{SINK}	V _{COMP} = 2V, V _{FB} = 0.65V	150	250	350	μA
COMP Source Current	I _{SOURCE}	V _{COMP} = 2V, V _{FB} = 0V	70	115	160	μA
Power Switch On-Resistance	R _{DSON}	I _{DS} = 1A		0.1	0.2	Ω
Switch Leakage Current	I _{LEAK}	V _{DRAIN} = 48V, V _{COMP} = 0V			25	μA
DRAIN Rise Time	t _{RDRAIN}	I _{DS} = 1A		10		ns
DRAIN Fall Time	t _{FDRAIN}	I _{DS} = 1A		10		ns
SOURCE Limit Threshold	V _{SOURCE} ETH	SOURCE connected to FB	0.66	0.72	0.78	V

Electrical Characteristics (continued)

($V_{IN} = 12V$; $V_{EXT} = V_{SOURCE} = V_{FB} = V_{GND} = 0V$; COMP, REFI, and DRAIN = open; $T_A = T_J = -40^{\circ}C$ to $+125^{\circ}C$, unless otherwise noted. Typical values are at $T_A = +25^{\circ}C$.) (Note 2)

PARAMETER	SYMBOL	CONDITIONS	MIN	TYP	MAX	UNITS
SOURCE Current-Limit Comparator Propagation Delay				25		ns
FB Input Bias Current	I_{FB}	$V_{FB} = 0V$ and $V_{FB} = 0.3V$	-1		+1	μA
FB Current-Limit Comparator Leading-Edge Blanking				50		ns
REFI Source Current		$V_{REFI} = 1.224V$	47.5	50	52.5	μA
Foldback Kick in Threshold		Falling on REFI	1.135	1.2	1.255	V
FB Average Voltage During Foldback		$V_{REFI} = 1.15V$	178	189	201	mV
		$V_{REFI} = 1V$	153	164.5	176	
		$V_{REFI} = 0.8V$	120	132	143	
FB Average Voltage to REFI Gain		$V_{REFI} = 1V$		6.075		
EXT Drive Current		$V_{IN} = 2V$, $V_{EXT} = 1V$	12.5	40		mA
EXT Pulldown Resistance			5	10	20	$k\Omega$
Thermal-Shutdown Temperature		Temperature rising		165		$^{\circ}C$
Thermal Shutdown Hysteresis				15		$^{\circ}C$

Note 2: All devices are 100% tested at $T_A = T_J = +25^{\circ}C$. Limits over temperature are guaranteed by design.

Typical Operating Characteristics

(TA = +25°C, unless otherwise noted.)

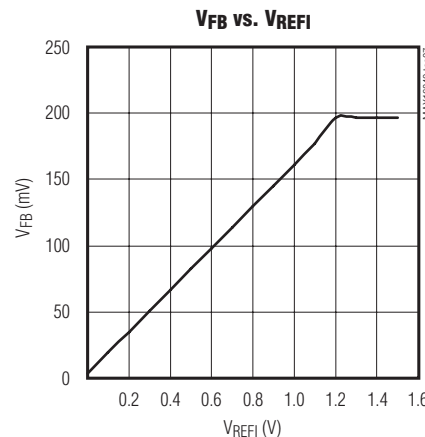
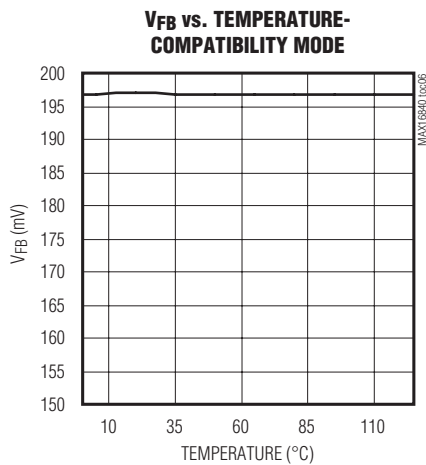
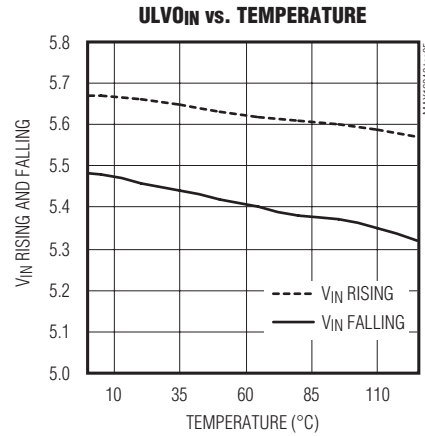
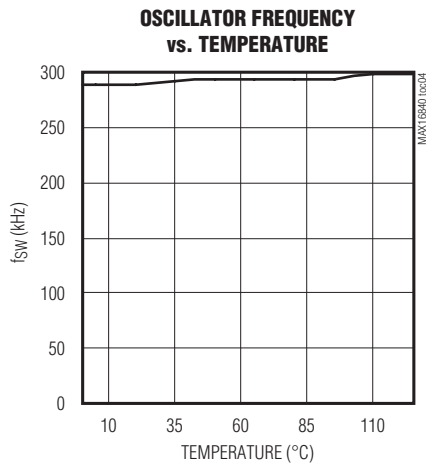
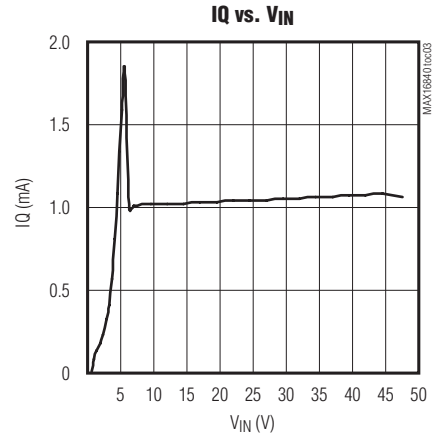
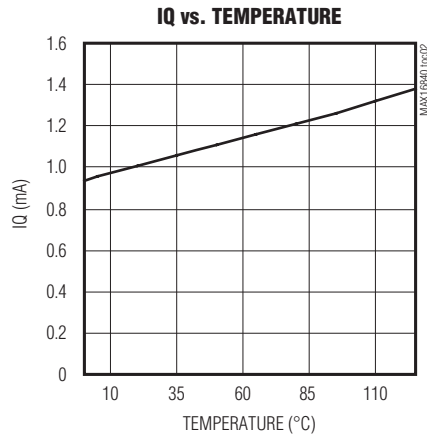
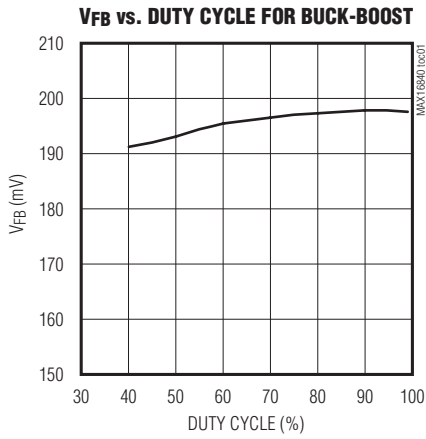

Pin Configuration

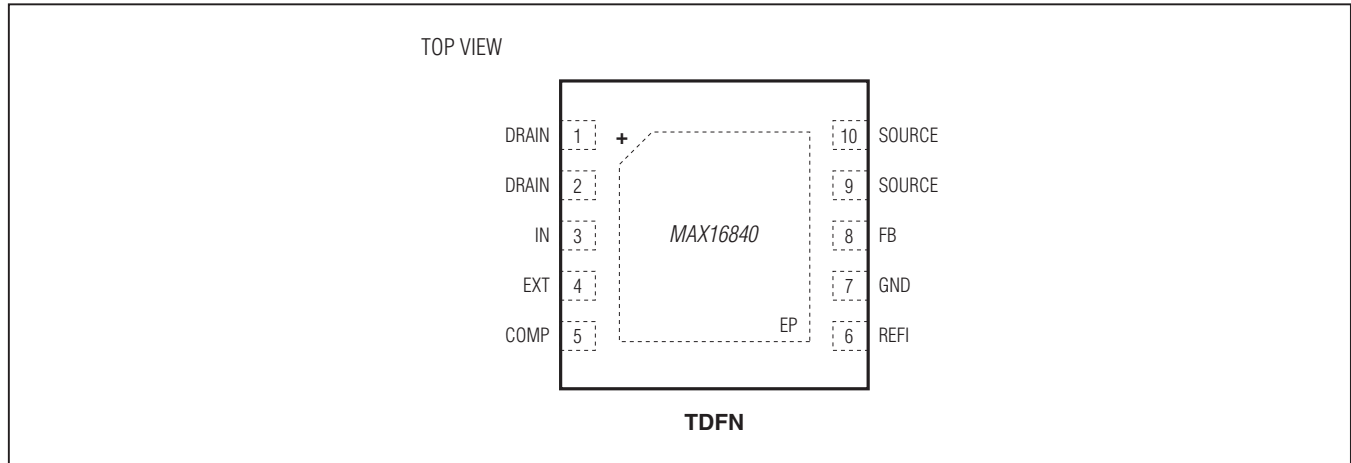

Pin Description

PIN	NAME	FUNCTION
1, 2	DRAIN	Drain of the Internal Switching MOSFET
3	IN	Input. Connect to LED string anode in boost and buck-boost configuration to get OVP protection during open LED. Bypass it with a sufficient capacitor not to allow IN to go below 6.5V in buck applications.
4	EXT	Base Drive for External Bipolar Until Internal Driver Starts Switching for the First Time After Power-Up
5	COMP	Compensation Component Connection for the Switching Stage. Connect a suitable RC network to ground. This is the output of the g_m amplifier
6	REFI	Analog Dimming and Thermal Foldback. The IC sources 50 μ A current out of this pin. Whenever this pin voltage is > 1.2V, the FB voltage is regulated to internal 200mV reference. Whenever this pin voltage < 1.2V, the FB voltage is regulated to $V_{REFI}/6$. Leave this pin unconnected to disable this foldback feature.
7	GND	Ground
8	FB	Current-Sense. This pin includes a 5k Ω /4pF RC filter at its input to average the current information over the switching cycle. Connect this pin directly to SOURCE.
9, 10	SOURCE	Source of the Internal Switching MOSFET
—	EP	Exposed Pad. Connect EP to the ground plane for heatsinking. Do not use the EP as the only electrical connection to ground.

Functional Diagram

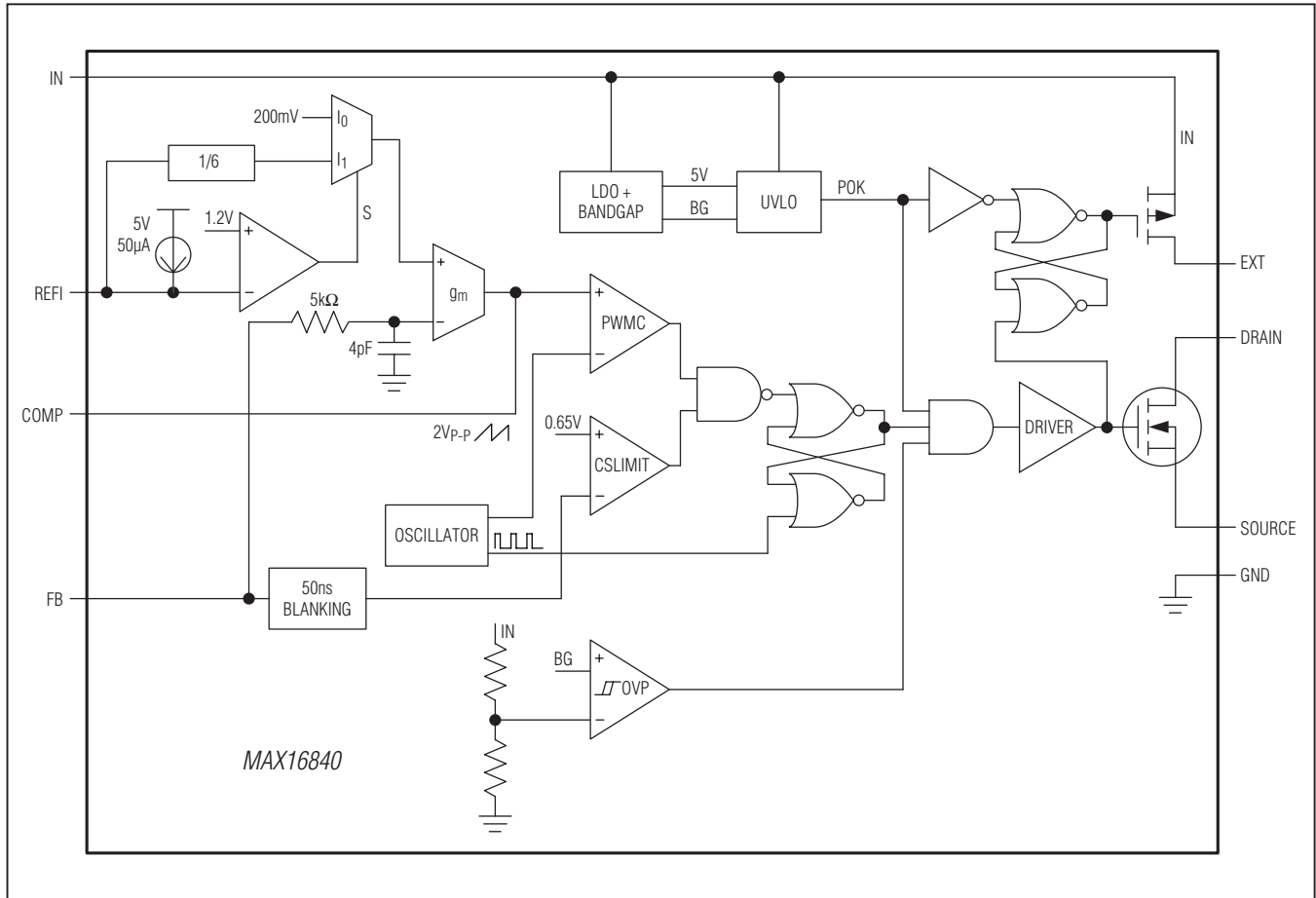

Detailed Description

The MAX16840 is an average current-mode control LED driver IC for buck, boost, and buck-boost topologies in low-voltage SSL applications. The IC has an integrated 0.2Ω (max), 48V switching MOSFET that allows the device to be used in lighting applications for MR16 and other SSL applications. The LED driver uses constant-frequency average current-mode control to control the duty cycle of the integrated switching MOSFET. The IC has all the necessary features required for MR16 lighting applications using LEDs. The IC uses an input-current control scheme to achieve power factor correction. This feature allows the IC to be compatible with electronic transformers and dimmable with trailing-edge (for electronic transformers).

The switch current is sensed on FB. The voltage on FB goes through an RC filter as shown in the *Functional Diagram*. This voltage is then fed to the negative input of a transconductance amplifier. The positive input of the gm amplifier is the programmed input current level. The output voltage of the gm amplifier is compared with a ramp at the switching frequency to set the duty cycle. The switching frequency is set at 300kHz. The average current-mode controller inside the IC regulates the input current. The IC also features an internal overvoltage protection of 46V on IN to protect the internal switching MOSFET from damage if the LED string is open or if the voltage on the LED string is too high.

The IC has a control pin, REFI, to program the input current. The IC regulates the average voltage on FB to 200mV if REFI is left open. A control voltage on REFI can be used to control the input current. The average voltage on FB is regulated to $V_{REFI}/6$, where V_{REFI} is the voltage on REFI. The linear control of the FB voltage ceases once the voltage on REFI exceeds 1.2V. Once the voltage increases beyond 1.2V, the voltage on FB is regulated to 200mV. REFI has an internal current source of 50 μ A and the voltage on REFI can also be set with a resistor to ground on REFI. This pin can also be used with an NTC resistor on the pin to achieve thermal foldback.

The IC has a separate EXT pin that can be used to guarantee that there is a kick-start of current at turn-on for low-input voltages for proper operation with electronic transformers. EXT drives an external npn transistor. Once the regulator MOSFET switches for the first time, after the IN voltage has passed the 5.5V UVLO threshold, EXT is pulled to ground and the external npn transistor is turned off.

Internal Oscillator

The IC has an internal oscillator with a fixed switching frequency of 300kHz.

Input Voltage (IN)

The IC is powered by the voltage on IN. The operating voltage range on IN is from 6.5V to 48V. An internal UVLO is set at 5.6V. Below 5.4V, there is no switching of the internal power MOSFET and the gate driver for the MOSFET is low. The typical hysteresis of the UVLO threshold is 200mV. There is an internal LDO of 5V that is used to power all the internal circuitry and the gate driver for the internal switching MOSFET. An internal overvoltage protection on IN stops switching once the voltage on IN exceeds 46V. The switching of the internal MOSFET ceases once the rising voltage on IN exceeds 46V and stays off until the voltage on IN drops by 1.2V from the OVP threshold of 46V.

External BJT Driver (EXT)

EXT is a separate driver for an external npn transistor that is used to drive an external resistive load when the input voltage on IN is below the UVLO. This is useful for operation with electronic transformers at low-input voltages. The minimum current capability of this pin is 20mA.

Internal Switching MOSFET

The IC has an integrated switching MOSFET with a maximum $R_{DS(on)}$ of 0.2 Ω at +125°C. The typical $R_{DS(on)}$ at +25°C is 0.1 Ω . This allows the IC to be used in a boost LED driver for power levels up to 20W and for buck-boost applications in MR16s for power levels up to 7W. The maximum voltage rating of the MOSFET is 48V operation. The drain of the internal MOSFET is connected to the DRAIN pin and the source of the internal MOSFET is connected to the SOURCE pin.

Current Sense (FB)

The source of the internal MOSFET is connected to SOURCE, so a current-sense resistor must be connected between SOURCE and ground and the current information is read by FB, so SOURCE must be connected to FB. The set point of the current is determined by REFI. If REFI is left open, the average current-sense voltage on FB is regulated by the IC's control loop to 200mV. There is a separate peak-limit comparator that terminates switching every cycle if the voltage on FB exceeds 650mV. This comparator has a leading-edge blanking time of 50ns.

Control Loop

The IC uses an average current-mode control scheme to regulate the input current (Figure 1). The control loop regulates the average voltage on FB. An internal RC filter removes current spikes appearing on this pin. Additional filtering can be added if necessary. The current-regulation loop consists of the current-sense resistor RCS, the RC filter shown in Figure 1, the transconductance error amplifier (g_m), an oscillator providing the 300kHz ramp, the control voltage on the positive input of the g_m amplifier, and the PWM comparator (PWMC).

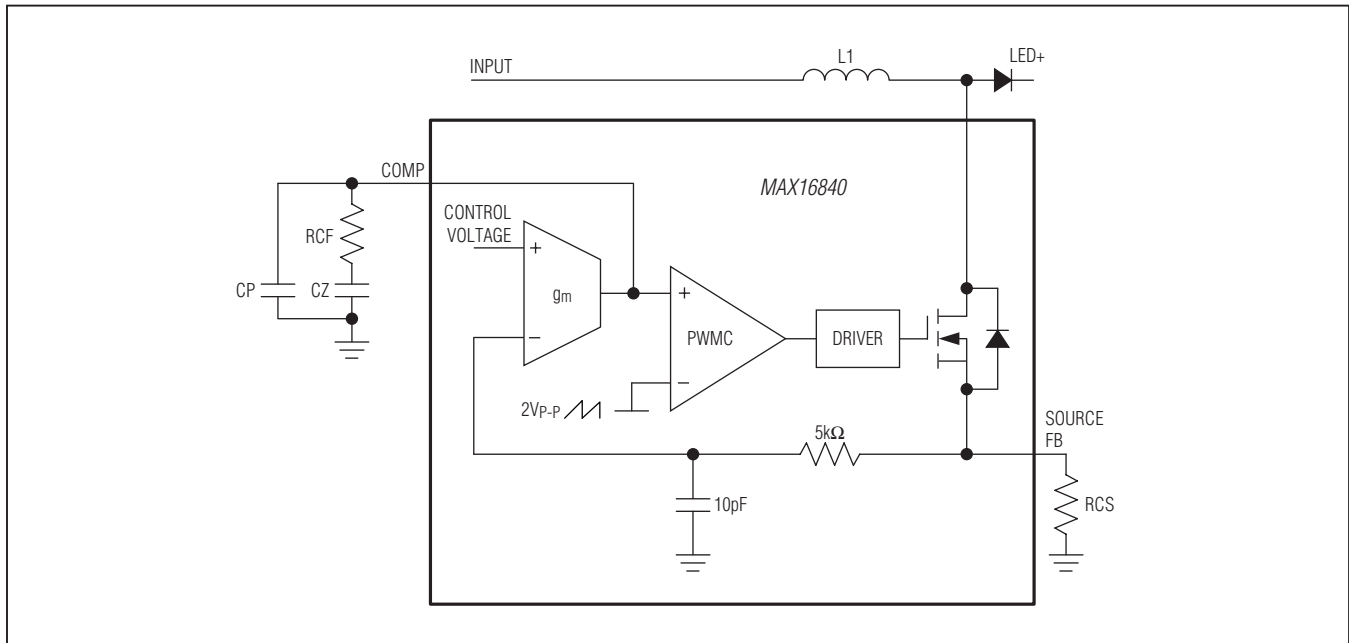

Figure 1. Control Loop

Peak-Limit Comparator

The IC has a peak-limit comparator that limits the peak current in the switching MOSFET. If the current-sense voltage on FB exceeds 0.65V, the peak-limit comparator terminates switching for that switching cycle. This limits the peak current in the switching MOSFET and the inductor during transients.

PWM Comparator

The PWM comparator (PWMC) determines the on-time of the switching MOSFET on a cycle-by-cycle basis by comparing the output of the gm amplifier to a 2VP-P ramp signal. At the start of each clock cycle, an RS flip-flop resets and the gate driver turns on the switching MOSFET. The comparator sets the flip-flop as soon as the ramp signal exceeds the COMP voltage, thus terminating the on cycle.

Current-Reference Input (REFI)

The IC has a current-reference input (REFI). For $V_{REFI} > 1.2V$, an internal reference sets the input average current to $200mV/RCS$. For $V_{REFI} < 1.2V$, the input current is reduced proportionally to V_{REFI} , and it can be reduced down to zero. The maximum withstand voltage of this input is 6V. REFI has an internal current source of $50\mu A$, and the voltage on REFI can also be set with a resistor to ground on REFI. This pin can also be used with an NTC resistor on the pin to achieve thermal foldback.

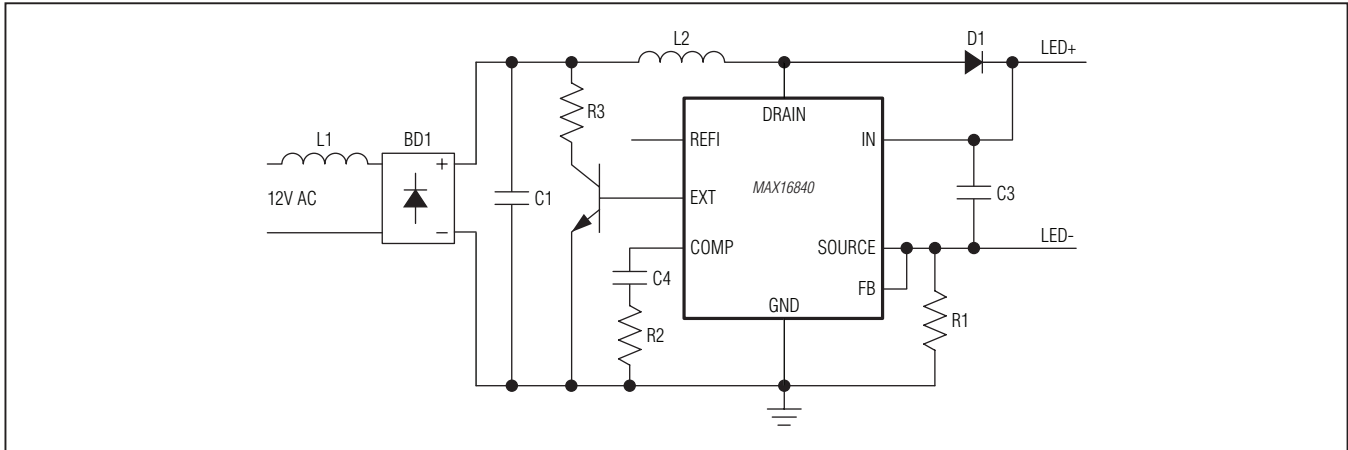

Figure 2. Boost LED Driver

Applications information

Boost Configuration

In MR16 and other 12V AC input applications, the boost configuration is used when the LED string voltage exceeds 18V. This means that, in general, if the number of LEDs in series in the application is greater than or equal to 6 LEDs, the IC can be used in the boost configuration to provide the best efficiency. Figure 2 shows a boost MR16 application. The number of LEDs can range from 6 to 10 LEDs. The maximum voltage across the LED string should not exceed 40V.

In the boost configuration, the current in the inductor is the same as the current in the current-sense resistor R1.

Resistor (R1)

The current in resistor R1 is the same as the current in inductor L2. If the desired maximum output power with 12V AC at 50Hz or 60Hz is P_{OUT} , the input power P_{IN} is given:

$$P_{IN} = P_{OUT}/n$$

where n is the efficiency. The input current is given by:

$$I_{IN} = P_{IN}/10.8V$$

Resistor R1 is then given by:

$$R1 = 0.2V/I_{IN}$$

where R1 is in ohms and I_{IN} is in amps.

Boost Inductor (L2)

For optimum efficiency, the boost inductor must be operating in continuous-conduction mode. The maximum

peak current in the inductor occurs at the peak of the highest input voltage. The p-p ripple at this input voltage is ΔI_L . The highest input voltage is 13.2V AC, which is 10% higher than the typical value.

The peak current in the inductor is:

$$I_{PK} = I_{IN} + 0.5\Delta I_L$$

The output voltage of the LED string is given by V_{LED} . As a first-order approximation, the LED voltage is assumed constant. The duty cycle at the peak of the input voltage is therefore:

$$D_{MIN} = 1 - \frac{13.2V \times \sqrt{2}}{V_{LED}} = 1 - \frac{18.66V}{V_{LED}}$$

The percentage p-p ripple is typically selected in the 30% to 60% range of the maximum input current. Assuming a 60% p-p inductor-current ripple, the maximum inductor current is given by:

$$I_{PK} = 1.3I_{INMAX}$$

The minimum inductor value is given by:

$$L_{MIN} = \frac{18.66V \times D_{MIN}}{0.6I_{INMAX} \times 300kHz}$$

where the switching frequency is 300kHz. The saturation current of the inductor should be higher than p-p and the minimum value of the inductor at I_{p-p} should exceed L_{MIN} .

The temperature of the inductor can be in the +90°C to +100°C range in the application and the losses should be estimated at these elevated temperatures.

Boost Diode (D1)

A Schottky diode must be used as rectifier diode D1 to reduce power dissipation. The voltage rating of diode D1 must be greater than the maximum output voltage. Choose a diode that minimizes dissipation at temperatures in the +90° to +100°C range. The diode should be selected to minimize reverse leakage at the maximum output voltage while minimizing forward losses when the diode is conducting.

Loop Compensation (R2, C4)

The crossover frequency of the loop must be maximized to get the optimum performance. The maximum value of R2 is given by:

$$R2_{MAX} = \frac{2 \times 300kHz \times L2}{R1 \times V_{LED} \times g_m} \text{ in } k\Omega$$

where R1 is in ohms, V_{LED} is in volts, g_m is the transconductance of the error amplifier in μS, and the value of the inductor L2 is in μH. Choose a value of R2 20% lower than the above value.

The zero from C4, R2 should be placed at:

$$f_z = \frac{R1 \times V_{LED} \times g_m \times R2}{12V \times \pi \times L}$$

Therefore, C4 is given by:

$$C4 = \frac{1}{2 \times \pi \times f_z \times R2}$$

Buck-Boost Configuration

In MR16 applications, the buck-boost configuration is used when the number of LEDs is in the 3-to-5 LED range. Figure 3 shows the schematic of a buck-boost LED driver. The maximum voltage on LED+ should not exceed 40V.

Resistor (R1)

If the desired maximum output power with 12V AC at 50Hz or 60Hz is P_{OUT}, the input power P_{IN} is given:

$$P_{IN} = P_{OUT}/\eta$$

where η is the efficiency. The input current is given by:

$$I_{IN} = P_{IN}/12V$$

The resistor R1 is then given by:

$$R1 = 0.2V/I_{IN}$$

where R1 is in ohms and I_{IN} is in amps.

Buck-Boost Inductor (L2)

For optimum efficiency, the inductor must be operating in continuous-conduction mode. The maximum peak current in the inductor occurs at the peak of the highest input voltage. The P-P ripple at this input voltage is ΔI_L. The maximum input current occurs at the highest input voltage. Typically, the highest input voltage is 13.2V AC, which is 10% higher than the typical value.

The peak current in the inductor is:

$$I_{PK} = I_{INDMIN} + 0.5\Delta I_L$$

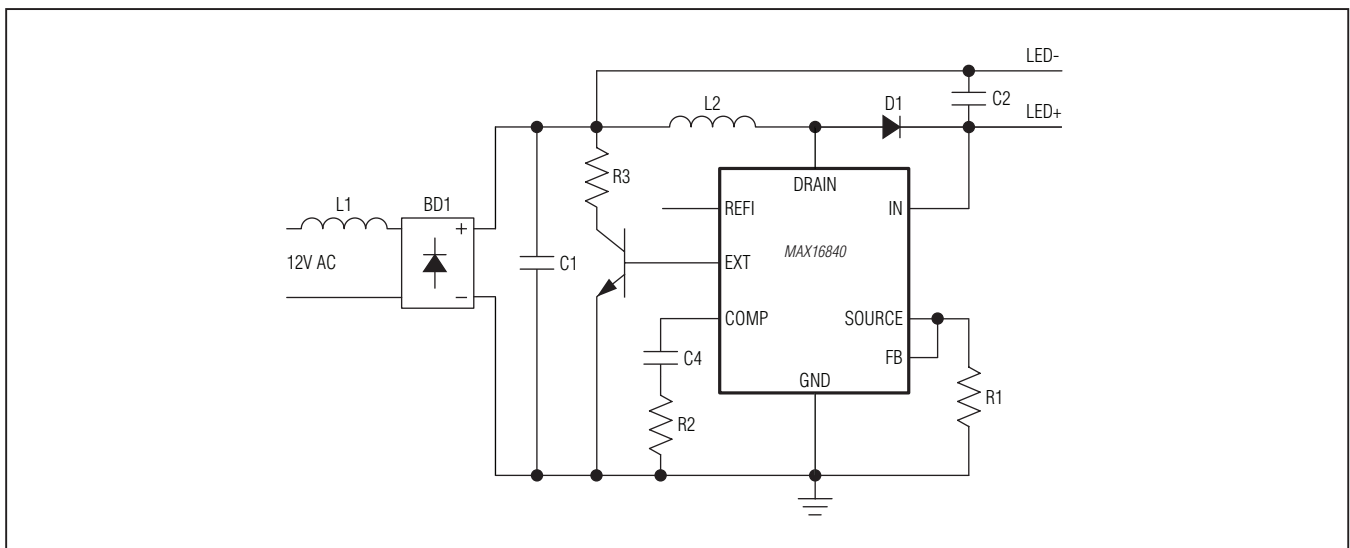

Figure 3. Buck-Boost LED Driver

The output voltage of the LED string is given by V_{LED} . As a first-order approximation, the LED voltage is assumed constant. The duty cycle at the peak of the input voltage is, therefore:

$$D_{MIN} = 1 - \frac{13.2V \times \sqrt{2}}{V_{LED} + 13.2V \times \sqrt{2}} = 1 - \frac{18.66V}{V_{LED} + 18.66V}$$

The percentage P-P ripple is typically selected in the 30% to 60% range of the maximum input current. Assuming a 60% P-P inductor-current ripple, the maximum inductor current is given by:

$$I_{P-P} = 1.3I_{IN}$$

The minimum inductor value is given by:

$$L_{MIN} = \frac{18.66V \times D_{MIN}^2}{0.6I_{IN} \times 300kHz}$$

where the switching frequency is 300kHz. The saturation current of the inductor should be higher than I_{P-P} and the minimum value of the inductor at I_{P-P} should exceed L_{MIN} .

Output Diode (D1)

A Schottky diode must be used as rectifier diode D1 to reduce power dissipation. The voltage rating of diode D1 must be greater than the maximum peak input voltage plus the maximum output voltage. Choose a diode that minimizes dissipation at temperatures in the +90°C to +100°C range. The diode should be selected to minimize reverse leakage at the maximum output voltage while minimizing forward losses when the diode is conducting.

Package Information

For the latest package outline information and land patterns (footprints), go to www.maximintegrated.com/packages. Note that a "+", "#", or "-" in the package code indicates RoHS status only. Package drawings may show a different suffix character, but the drawing pertains to the package regardless of RoHS status.

PACKAGE TYPE	PACKAGE CODE	OUTLINE NO.	LAND PATTERN NO.
10 TDFN-EP	T1033+1	21-0137	90-0003

Revision History

REVISION NUMBER	REVISION DATE	DESCRIPTION	PAGES CHANGED
0	12/10	Initial release	—
1	2/11	Changed minimum temperature to -40°C	1, 2, 3, 8
2	5/11	Added missing dots in <i>Typical Operating Circuit</i> and Figure 3	1, 10
3	8/11	Added missing dots in <i>Typical Operating Circuit</i> and Figure 3 and updated PWM block in Figure 1	1, 8, 10
4	1	Updated <i>Benefits and Features</i> section	1

For pricing, delivery, and ordering information, please contact Maxim Direct at 1-888-629-4642, or visit Maxim Integrated's website at www.maximintegrated.com.

Maxim Integrated cannot assume responsibility for use of any circuitry other than circuitry entirely embodied in a Maxim Integrated product. No circuit patent licenses are implied. Maxim Integrated reserves the right to change the circuitry and specifications without notice at any time. The parametric values (min and max limits) shown in the Electrical Characteristics table are guaranteed. Other parametric values quoted in this data sheet are provided for guidance.

Компания «Океан Электроники» предлагает заключение долгосрочных отношений при поставках импортных электронных компонентов на взаимовыгодных условиях!

Наши преимущества:

- Поставка оригинальных импортных электронных компонентов напрямую с производств Америки, Европы и Азии, а так же с крупнейших складов мира;
- Широкая линейка поставок активных и пассивных импортных электронных компонентов (более 30 млн. наименований);
- Поставка сложных, дефицитных, либо снятых с производства позиций;
- Оперативные сроки поставки под заказ (от 5 рабочих дней);
- Экспресс доставка в любую точку России;
- Помощь Конструкторского Отдела и консультации квалифицированных инженеров;
- Техническая поддержка проекта, помощь в подборе аналогов, поставка прототипов;
- Поставка электронных компонентов под контролем ВП;
- Система менеджмента качества сертифицирована по Международному стандарту ISO 9001;
- При необходимости вся продукция военного и аэрокосмического назначения проходит испытания и сертификацию в лаборатории (по согласованию с заказчиком);
- Поставка специализированных компонентов военного и аэрокосмического уровня качества (Xilinx, Altera, Analog Devices, Intersil, Interpoint, Microsemi, Actel, Aeroflex, Peregrine, VPT, Syfer, Eurofarad, Texas Instruments, MS Kennedy, Miteq, Cobham, E2V, MA-COM, Hittite, Mini-Circuits, General Dynamics и др.);

Компания «Океан Электроники» является официальным дистрибьютором и эксклюзивным представителем в России одного из крупнейших производителей разъемов военного и аэрокосмического назначения «JONHON», а так же официальным дистрибьютором и эксклюзивным представителем в России производителя высокотехнологичных и надежных решений для передачи СВЧ сигналов «FORSTAR».



JONHON

«JONHON» (основан в 1970 г.)

Разъемы специального, военного и аэрокосмического назначения:

(Применяются в военной, авиационной, аэрокосмической, морской, железнодорожной, горно- и нефтедобывающей отраслях промышленности)

«FORSTAR» (основан в 1998 г.)

ВЧ соединители, коаксиальные кабели, кабельные сборки и микроволновые компоненты:

(Применяются в телекоммуникациях гражданского и специального назначения, в средствах связи, РЛС, а так же военной, авиационной и аэрокосмической отраслях промышленности).



Телефон: 8 (812) 309-75-97 (многоканальный)

Факс: 8 (812) 320-03-32

Электронная почта: ocean@oceanchips.ru

Web: <http://oceanchips.ru/>

Адрес: 198099, г. Санкт-Петербург, ул. Калинина, д. 2, корп. 4, лит. А