



Is Now Part of



ON Semiconductor®

To learn more about ON Semiconductor, please visit our website at
www.onsemi.com

Please note: As part of the Fairchild Semiconductor integration, some of the Fairchild orderable part numbers will need to change in order to meet ON Semiconductor's system requirements. Since the ON Semiconductor product management systems do not have the ability to manage part nomenclature that utilizes an underscore (_), the underscore (_) in the Fairchild part numbers will be changed to a dash (-). This document may contain device numbers with an underscore (_). Please check the ON Semiconductor website to verify the updated device numbers. The most current and up-to-date ordering information can be found at www.onsemi.com. Please email any questions regarding the system integration to Fairchild_questions@onsemi.com.

ON Semiconductor and the ON Semiconductor logo are trademarks of Semiconductor Components Industries, LLC dba ON Semiconductor or its subsidiaries in the United States and/or other countries. ON Semiconductor owns the rights to a number of patents, trademarks, copyrights, trade secrets, and other intellectual property. A listing of ON Semiconductor's product/patent coverage may be accessed at www.onsemi.com/site/pdf/Patent-Marking.pdf. ON Semiconductor reserves the right to make changes without further notice to any products herein. ON Semiconductor makes no warranty, representation or guarantee regarding the suitability of its products for any particular purpose, nor does ON Semiconductor assume any liability arising out of the application or use of any product or circuit, and specifically disclaims any and all liability, including without limitation special, consequential or incidental damages. Buyer is responsible for its products and applications using ON Semiconductor products, including compliance with all laws, regulations and safety requirements or standards, regardless of any support or applications information provided by ON Semiconductor. "Typical" parameters which may be provided in ON Semiconductor data sheets and/or specifications can and do vary in different applications and actual performance may vary over time. All operating parameters, including "Typicals" must be validated for each customer application by customer's technical experts. ON Semiconductor does not convey any license under its patent rights nor the rights of others. ON Semiconductor products are not designed, intended, or authorized for use as a critical component in life support systems or any FDA Class 3 medical devices or medical devices with a same or similar classification in a foreign jurisdiction or any devices intended for implantation in the human body. Should Buyer purchase or use ON Semiconductor products for any such unintended or unauthorized application, Buyer shall indemnify and hold ON Semiconductor and its officers, employees, subsidiaries, affiliates, and distributors harmless against all claims, costs, damages, and expenses, and reasonable attorney fees arising out of, directly or indirectly, any claim of personal injury or death associated with such unintended or unauthorized use, even if such claim alleges that ON Semiconductor was negligent regarding the design or manufacture of the part. ON Semiconductor is an Equal Opportunity/Affirmative Action Employer. This literature is subject to all applicable copyright laws and is not for resale in any manner.



FSUSB74

4:1 High-Speed USB Multiplexer/Switch

Features

Switch Type	4:1
USB	USB 2.0 High-Speed Compliant USB 2.0 Full-Speed Compliant
R _{ON}	6.5Ω
C _{ON}	7.5pF
ESD (IEC61000-4-2)	15kV (Air) 8kV (Contact)
V _{CC}	2.7 to 4.4V
I _{CCSLP}	<1μA
I _{CCACT}	9μA
Package	16- Lead UMLP 1.80 x 2.60 x 0.55mm, 0.40mm Pitch 16-Lead MLP 3 x 3 x 0.7mm, 0.5mm Pitch
Ordering Information	FSUSB74UMX (UMLP) FSUSB74MPX (MLP)

Description

The FSUSB74 is a bi-directional, low-power, high-speed USB 2.0 4:1 MUX. It is optimized for switching from four high-speed (480Mbps) sources or any combination of high-speed and full-/low-speed USB/UART sources to one USB 2.0 connector.

Applications

- MP3 Portable Media Players
- Cellular Phones, Smart Phones
- Netbooks, Mobile Internet Devices (MID)

Related Resources

- For samples and questions, please contact: Analog.Switch@fairchildsemi.com.
- FSUSB74 Demonstration Board
- FSUSB74 Evaluation Board

Typical Application

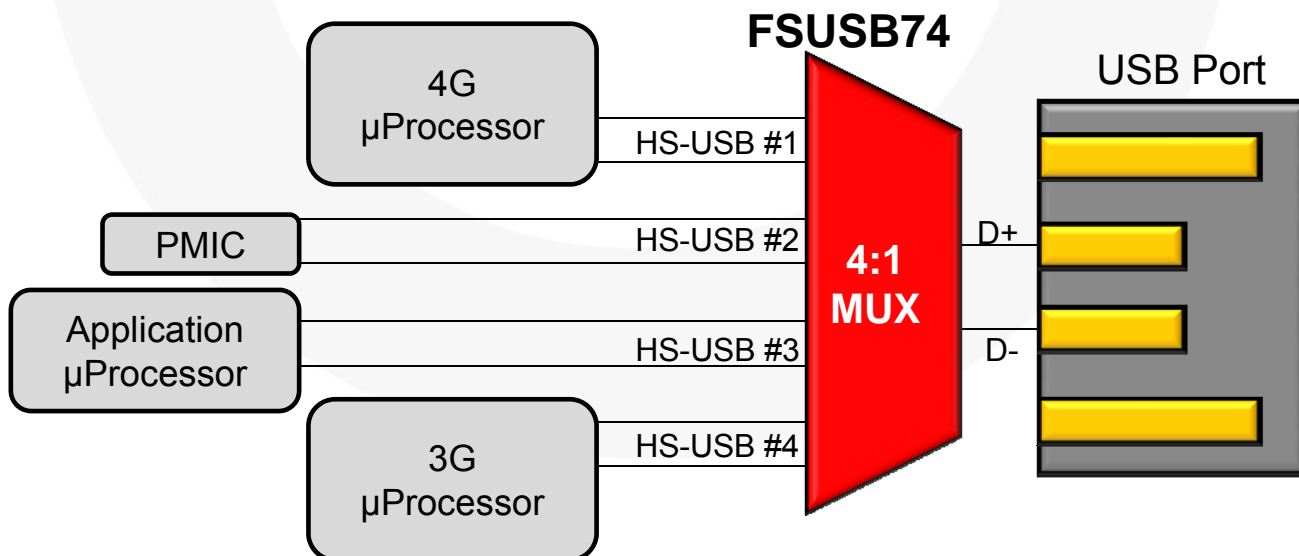

Figure 1. Mobile Phone Example

Pin Configurations

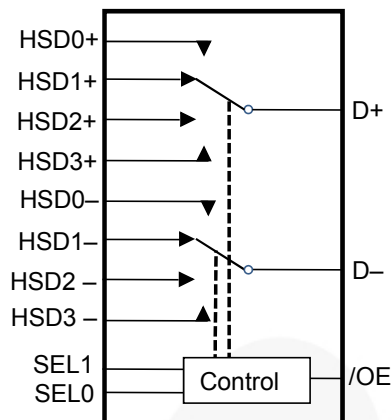

Figure 2. UMLP Analog Symbol

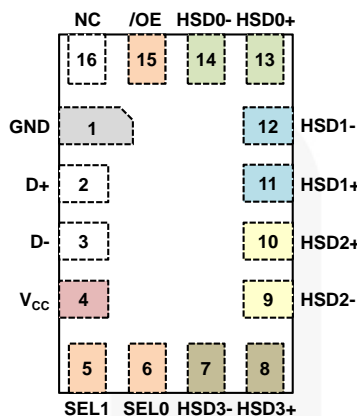

Figure 3. UMLP (Top View)

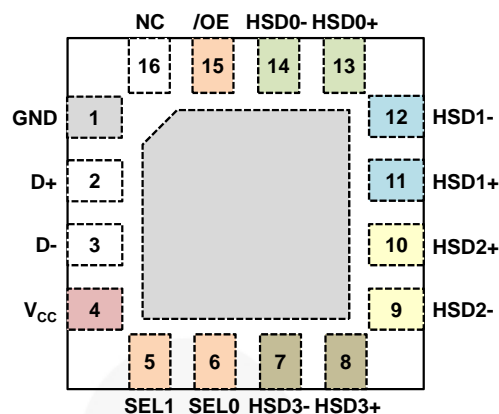

Figure 4. MLP (Top View)

Pin Descriptions

Pin #	Name	Type	Description
1	GND	Ground	Ground
2	D+	I/O	D+ common port (HS or FS USB)
3	D-	I/O	D- common port (HS or FS USB)
4	V _{CC}	Power Supply	Supply Voltage
5	SEL1	Input	Path Selection Control Input (see truth table below)
6	SEL0	Input	Path Selection Control Input (see truth table below)
7	HSD3-	I/O	D- from fourth source path (HS or FS USB)
8	HSD3+	I/O	D+ from fourth source path (HS or FS USB)
9	HSD2-	I/O	D- from third source path (HS or FS USB)
10	HSD2+	I/O	D+ from third source path (HS or FS USB)
11	HSD1+	I/O	D+ from second source path (HS or FS USB)
12	HSD1-	I/O	D- from second source path (HS or FS USB)
13	HSD0+	I/O	D+ from first source path (HS or FS USB)
14	HSD0-	I/O	D- from first source path (HS or FS USB)
15	/OE	Input	Enable Control Input (see truth table below)
16	NC		No Connect

Truth Table

/OE	SEL1	SEL0	Function
1	X	X	D+, D- Switch Paths Open
0	0	0	D+=HSD0+, D-=HSD0-
0	0	1	D+=HSD1+, D-=HSD1-
0	1	0	D+=HSD2+, D-=HSD2-
0	1	1	D+=HSD3+, D-=HSD3-

Absolute Maximum Ratings

Stresses exceeding the absolute maximum ratings may damage the device. The device may not function or be operable above the recommended operating conditions and stressing the parts to these levels is not recommended. In addition, extended exposure to stresses above the recommended operating conditions may affect device reliability. The absolute maximum ratings are stress ratings only.

Symbol	Parameter	Min.	Max.	Unit
V _{CC}	Supply Voltage	-0.5	5.25	V
V _{CNTRL}	DC Input Voltage (SEL1, SEL0, /OE, SELS) ⁽¹⁾	-0.50	V _{CC}	V
V _{SW}	DC Switch I/O Voltage ⁽¹⁾	-0.50	5.25	V
I _{IK}	DC Input Diode Current	-50		mA
T _{STG}	Storage Temperature	-65	+150	°C
MSL	Moisture Sensitivity Level (JEDEC J-STD-020A)		1	Level
ESD	IEC61000-4-2 System on USB connector pins D+ & D-	Air Gap	15	kV
		Contact	8	
	Human Body Model, JEDEC: JESD22-A114	D+,D- to GND	6	
		Power to GND	12	
		All Other Pins	2	

Note:

- The input and output negative ratings may be exceeded if the input and output diode current ratings are observed.

Recommended Operating Conditions

The Recommended Operating Conditions table defines the conditions for actual device operation. Recommended operating conditions are specified to ensure optimal performance to the datasheet specifications. Fairchild does not recommend exceeding them or designing to Absolute Maximum Ratings.

Symbol	Parameter	Min.	Max.	Unit
V _{CC}	Supply Voltage	2.5	4.4	V
V _{CNTRL} ⁽²⁾	Control Input Voltage (SEL1, SEL0, /OE, and SELS)	0	V _{CC}	V
V _{SW}	Switch I/O Voltage	-0.5	4.4	V
T _A	Operating Temperature	-40	+85	°C

Note:

- The control input must be held HIGH or LOW; it must not float.

DC Electrical Characteristics

All typical values are for $V_{CC}=3.3V$ at $25^{\circ}C$ unless otherwise specified.

Symbol	Parameter	Conditions	V_{CC} (V)	$T_A=-40^{\circ}C$ to $+85^{\circ}C$			Unit
				Min.	Typ.	Max.	
$R_{ON}^{(3)}$	HS Switch On Resistance	$V_{SW}=0.4V$, $I_{ON}=-8mA$, Figure 5	3.3		6.5	9.0	Ω
$\Delta R_{ON}^{(3)}$	HS Delta Ron ⁽⁴⁾	$V_{SW}=0.4V$, $I_{ON}=-8mA$	3.3		0.5		Ω
I_{IN}	Control Input Leakage	All Combinations of /OE, SEL1 & SEL0 in the Truth Table (1= V_{CC} , 0=0V)	4.4	-1		1	μA
I_{OZ}	Off State Leakage	$0 \leq Dn$, HSD0n, HSD1n, HSD2n, HSD3n $\leq 4.4V$	4.4	-1		1	μA
I_{OFF}	Power-Off Leakage Current (All I/O Ports)	$V_{SW}=0V$ to $4.4V$, $V_{CC}=0V$, Figure 6	0	-1		1	μA
I_{CCSLP}	Sleep Mode Supply Current	/OE= V_{CC}	4.4			1	μA
I_{CCACT}	Active Mode Supply Current	All Active Modes in Truth Table	4.4		9	18	μA
I_{CCT}	Increase in I_{CC} Current per Control Input and V_{CC}	$V_{CNTRL}=1.8V$	4.4		3.3	4.0	μA
		$V_{CNTRL}=1.2V$	4.4		4.9	6.0	μA
V_{IK}	Clamp Diode Voltage	$I_{IN}=-18mA$	2.5			-1.2	V
V_{IH}	Control Input Voltage High	SEL1, SEL0, /OE	2.5 to 4.4	1.0			V
V_{IL}	Control Input Voltage Low	SEL1, SEL0, /OE	2.5 to 4.4			0.35	V

Notes:

3. Measured by the voltage drop between HSDn and Dn pins at the indicated current through the switch. On resistance is determined by the lower of the voltage on the two (HSDn or Dn ports).
4. Guaranteed by characterization.

AC Electrical Characteristics

All typical values are for $V_{CC}=3.3V$ at $T_A=25^{\circ}C$ unless otherwise specified.

Symbol	Parameter	Conditions	V_{CC} (V)	$T_A=-40^{\circ}C$ to $+85^{\circ}C$			Unit
				Min.	Typ.	Max.	
t_{ON}	Turn-On Time when Switching from One USB Path (or Disabled i.e. /OE=1) to Another USB Path	$R_L=50\Omega$, $C_L=35pF$, $V_{SW}=0.8V$, Figure 7, Figure 8	2.5 to 4.4	126		400	μs
t_{OFF}	Turn-Off Time, Turning Off Any of the USB Paths	$R_L=50\Omega$, $C_L=35pF$, $V_{SW}=0.8V$, Figure 7, Figure 8	2.5 to 4.4			80	ns
t_{PD}	Propagation Delay ⁽⁵⁾	$C_L=5pF$, $R_L=50\Omega$, Figure 7, Figure 9	3.3		0.25		ns
t_{RF}	Slow Turn-On/Off Switch Paths ⁽⁵⁾	$C_L=5pF$, Dn at 0V or 3.6V, 40.5Ω in series with switch 10% to 90%	3.3		4.5		ns
t_{BBM}	Break-Before-Make Time ⁽⁵⁾	$R_L=50\Omega$, $C_L=35pF$, $V_{SW1}=V_{SW2}=0.8V$, Figure 11	2.5 to 4.4	126		400	μs
O_{IRR}	Off Isolation ⁽⁵⁾	$R_L=50\Omega$, $f=240MHz$, Figure 13	2.5 to 4.4		-40		dB
Xtalk	Channel-to-Channel Crosstalk ⁽⁵⁾	$R_L=50\Omega$, $f=240MHz$, Figure 14	2.5 to 4.4		-40		dB
$t_{SK(P)}$	Pulse Skew ⁽⁵⁾	$V_{SW}=0.2V_{diffPP}$, Figure 10, $C_L=5pF$	2.5 to 4.4		25		ps
$t_{SK(I)}$	Skew Between Differential Signals Within a Pair ⁽⁵⁾	$V_{SW}=0.2V_{diffPP}$, Figure 10, $C_L=5pF$	2.5 to 4.4		25		ps

Note:

5. Guaranteed by characterization.

Capacitance Characteristics

All typical values are for $V_{CC}=3.3V$ at $T_A=25^{\circ}C$ unless otherwise specified.

Symbol	Parameter	Conditions	V_{CC} (V)	Typical	Unit
C_{IN}	Input Capacitance ⁽⁶⁾		0	3	pF
C_{ON}	D+/D- On Capacitance ⁽⁶⁾	Any Switch Path Enabled, $f=1MHz$, Figure 16	3.3	7.5	
C_{OFF}	HSD0n, HSD1n, HSD2n, HSD3n Off Capacitance ⁽⁶⁾	If $V_{CC}=3.3V$, then /OE=3.3V; $f=1MHz$, Figure 15	0 or 3.3	2.2	

Note:

6. Guaranteed by characterization.

Test Diagrams

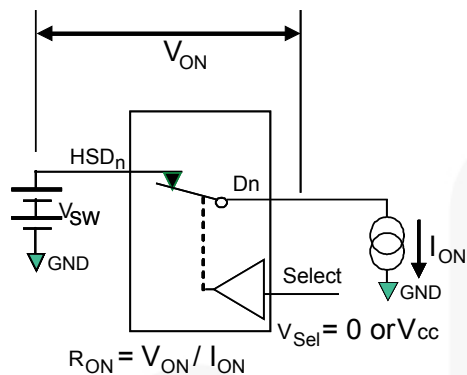
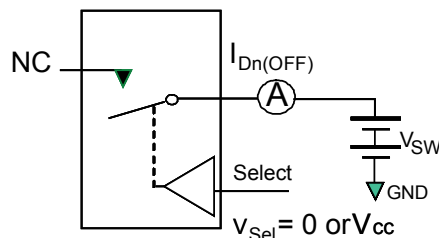
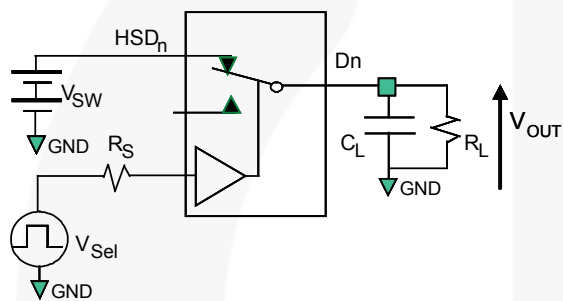

Figure 5. On Resistance



**Each switch port is tested separately

Figure 6. Off Leakage



R_L , R_S , and C_L are functions of the application environment (see AC Tables for specific values)
 C_L includes test fixture and stray capacitance.

Figure 7. AC Test Circuit Load

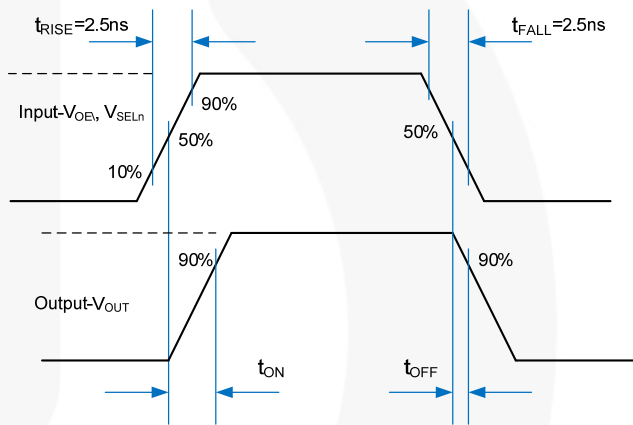

Figure 8. Turn-On / Turn-Off Waveforms

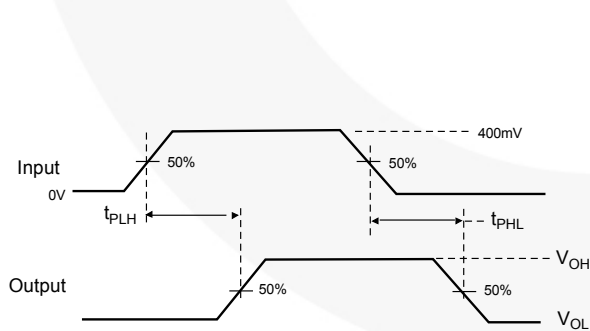

Figure 9. Propagation Delay ($t_{rF} - 500ps$)

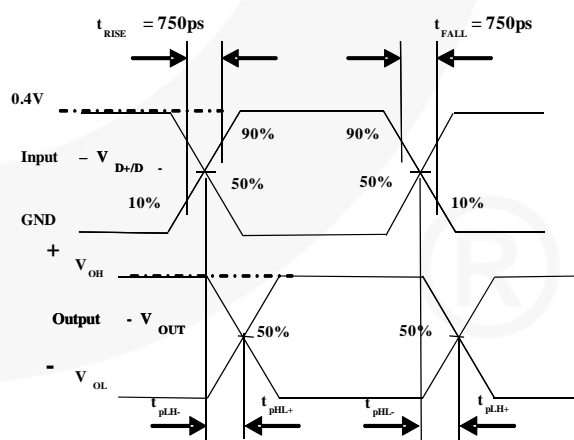

Figure 10. Skew Test Waveforms

$$t_{SK(P)} = |t_{PLH-} - t_{PHL-}| \text{ or } |t_{PLH+} - t_{PHL+}|$$

$$t_{SK(I)} = |t_{PLH-} - t_{PHL+}| \text{ or } |t_{PLH+} - t_{PHL-}|$$

Test Diagrams (Continued)

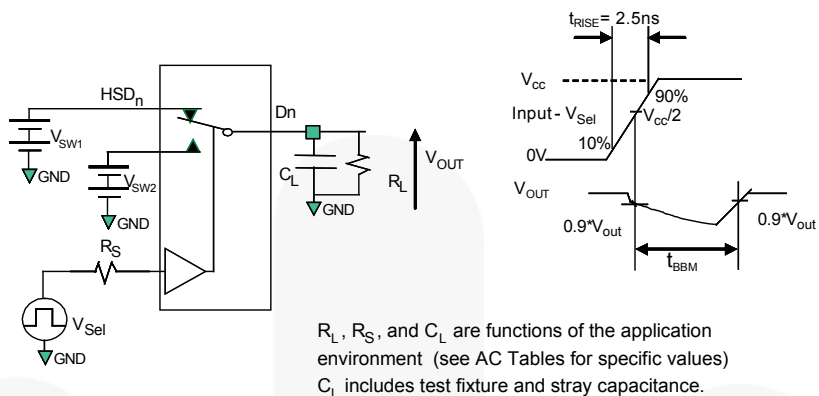

Figure 11. Break-Before-Make Interval Timing

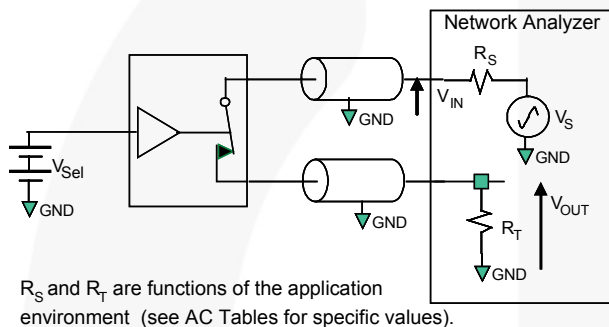

Figure 12. Bandwidth

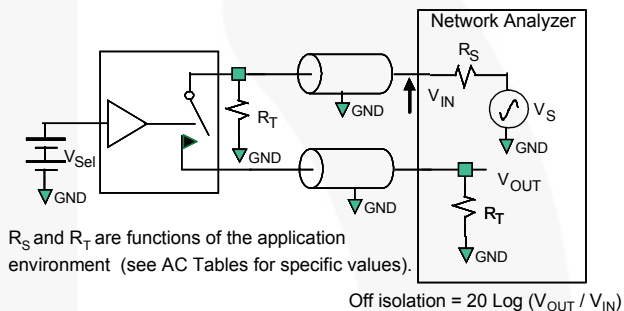

Figure 13. Channel Off Isolation

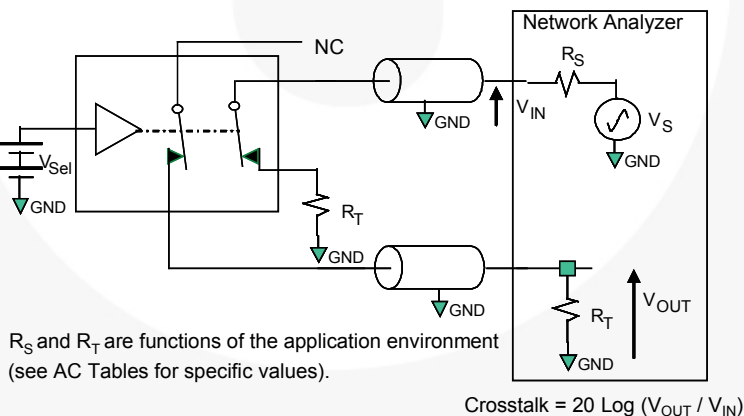

Figure 14. Non-Adjacent Channel-to-Channel Crosstalk

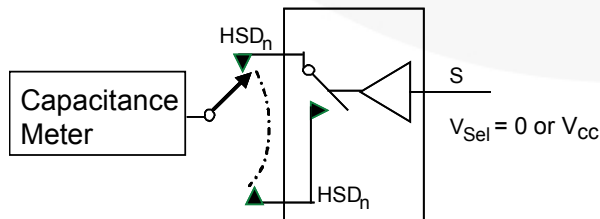

Figure 15. Channel Off Capacitance

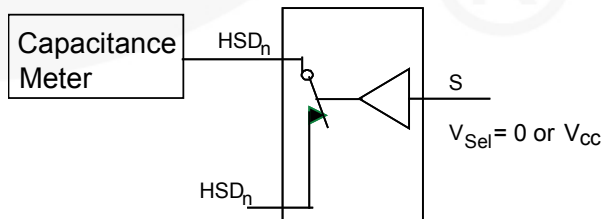
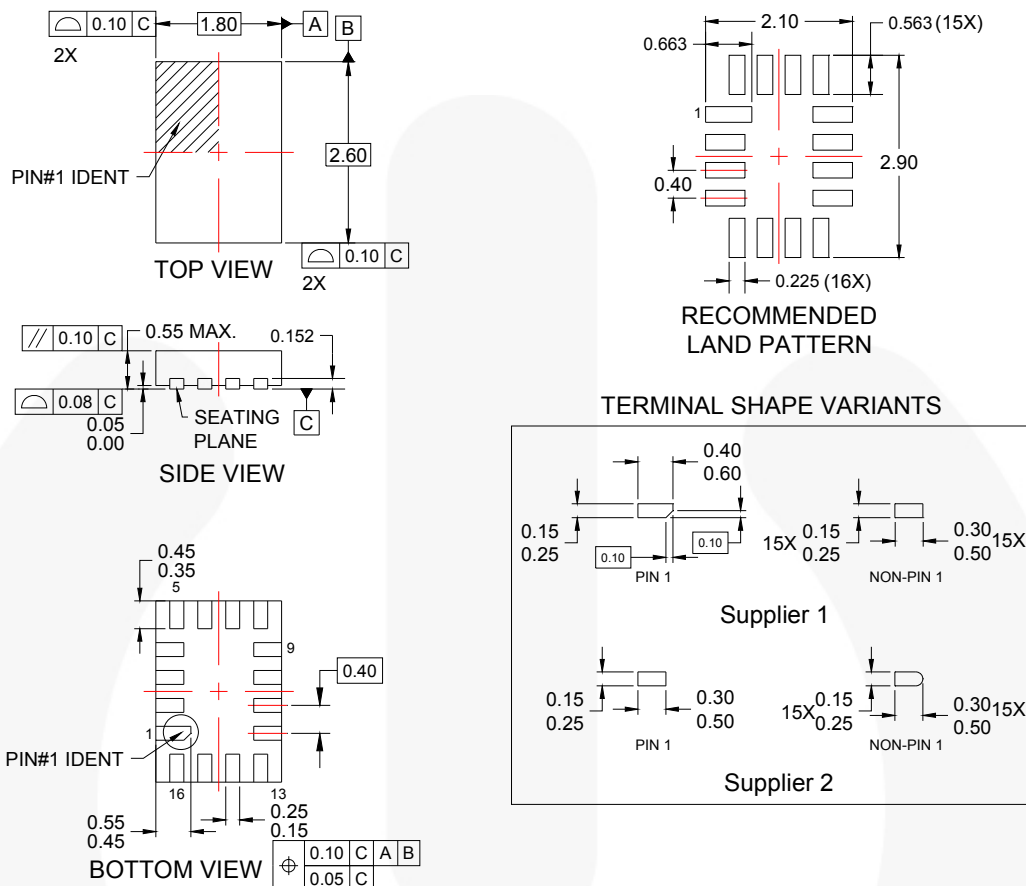

Figure 16. Channel On Capacitance

Physical Dimensions



NOTES:

- A. PACKAGE DOES NOT FULLY CONFORM TO JEDEC STANDARD.
- B. DIMENSIONS ARE IN MILLIMETERS.
- C. DIMENSIONS AND TOLERANCES PER ASME Y14.5M, 1994.
- D. LAND PATTERN RECOMMENDATION IS BASED ON FSC DESIGN ONLY.
- E. DRAWING FILENAME: MKT-UMLP16Arev4.
- F. TERMINAL SHAPE MAY VARY ACCORDING TO PACKAGE SUPPLIER, SEE TERMINAL SHAPE VARIANTS.

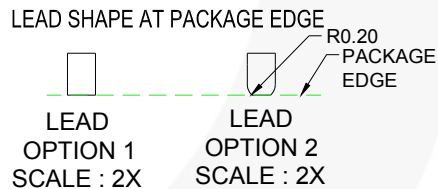

Figure 17. 16-Pin, Ultrathin Molded Leadless Package (UMLP)

Order Number	Operating Temperature Range	Package Description	Packing Method
FSUSB74UMX	-40 to 85°C	16-Terminal, Ultrathin Molded Leadless Package (UMLP)	Tape & Reel

Package drawings are provided as a service to customers considering Fairchild components. Drawings may change in any manner without notice. Please note the revision and/or date on the drawing and contact a Fairchild Semiconductor representative to verify or obtain the most recent revision. Package specifications do not expand the terms of Fairchild's worldwide terms and conditions, specifically the warranty therein, which covers Fairchild products.

Always visit Fairchild Semiconductor's online packaging area for the most recent package drawings: <http://www.fairchildsemi.com/packaging/>.

Physical Dimensions

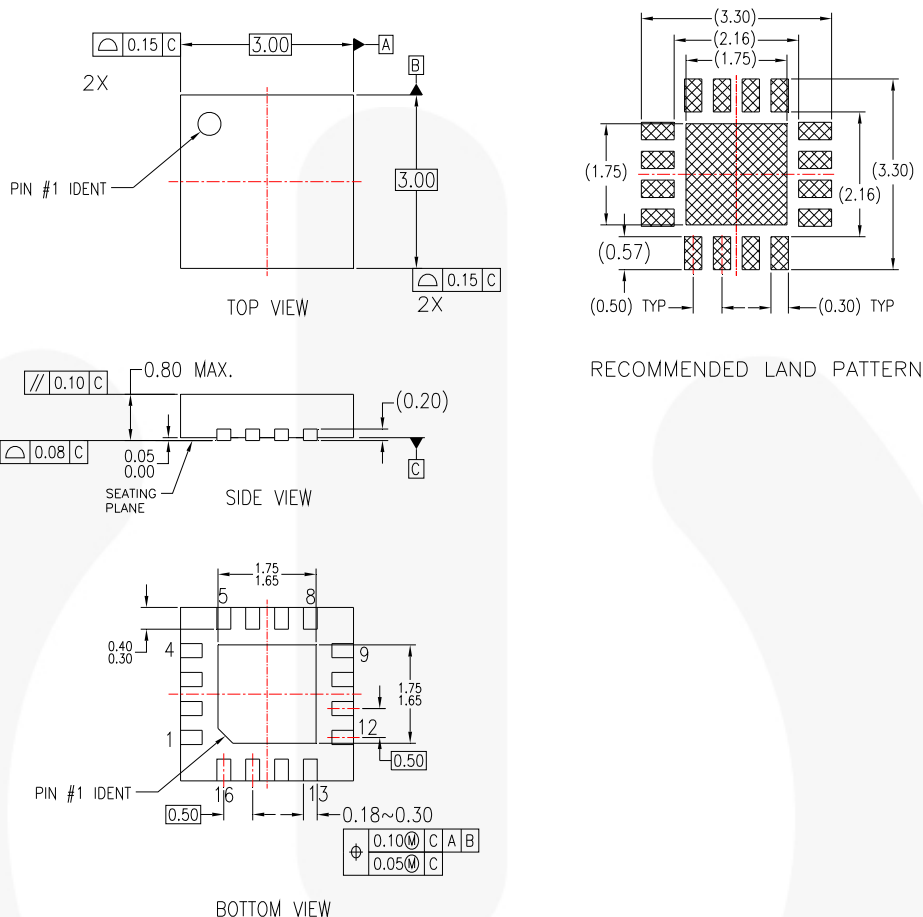

NOTES:

- A. CONFORMS TO JEDEC REGISTRATION MO-220, VARIATION WEED-Pending, DATED pending
- B. DIMENSIONS ARE IN MILLIMETERS.
- C. DIMENSIONS AND TOLERANCES PER ASME Y14.5M, 1994
- D. DIMENSIONS ARE EXCLUSIVE OF BURS, MOLD FLASH, AND TIE BAR EXTRUSIONS.

MLP16BrevB

Figure 18. 16-Lead, Quad Molded Leadless Package (MLP)

Order Number	Operating Temperature Range	Package Description	Packing Method
FSUSB74MPX	-40 to 85°C	16-Lead, Quad, Molded Leadless Package (MLP), 3mm x 3mm	Tape & Reel



Package drawings are provided as a service to customers considering Fairchild components. Drawings may change in any manner without notice. Please note the revision and/or date on the drawing and contact a Fairchild Semiconductor representative to verify or obtain the most recent revision. Package specifications do not expand the terms of Fairchild's worldwide terms and conditions, specifically the warranty therein, which covers Fairchild products.

Always visit Fairchild Semiconductor's online packaging area for the most recent package drawings: <http://www.fairchildsemi.com/packaging/>.



TRADEMARKS

The following includes registered and unregistered trademarks and service marks, owned by Fairchild Semiconductor and/or its global subsidiaries, and is not intended to be an exhaustive list of all such trademarks.

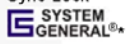
- | | | | |
|--|--|--|--|
| 2Cool™ | F-PFS™ | PowerTrench® | The Power Franchise® |
| AccuPower™ | FRFET® | PowerXS™ | the power franchise |
| AX-CAP™* | Global Power Resource™ | Programmable Active Droop™ | TinyBoost™ |
| BitSiC™ | GreenBridge™ | QFET® | TinyBuck™ |
| Build it Now™ | Green FPS™ | QS™ | TinyCalc™ |
| CorePLUS™ | Green FPS™ e-Series™ | Quiet Series™ | TinyLogic® |
| CorePOWER™ | Gmax™ | RapidConfigure™ | TINYOPTO™ |
| CROSSVOLT™ | GTO™ |  ™ | TinyPower™ |
| CTL™ | IntelliMAX™ | Saving our world, 1mW/W/kW at a time™ | TinyPWM™ |
| Current Transfer Logic™ | ISOPLANAR™ | SignalWise™ | TinyWire™ |
| DEUXPEED® | Making Small Speakers Sound Louder and Better™ | SmartMax™ | TranSiC™ |
| Dual Cool™ | MegaBuck™ | SMART START™ | TriFault Detect™ |
| EcoSPARK® | MICROCOUPLER™ | Solutions for Your Success™ | TRUECURRENT®* |
| EfficientMax™ | MicroFET™ | SPM® | µSerDes™ |
| ESBC™ | MicroPak™ | STEALTH™ |  SerDes |
|  Fairchild® | MicroPak2™ | SuperFET® | UHC |
| Fairchild Semiconductor® | MillerDrive™ | SuperSOT™-3 | Ultra FRFET™ |
| FACT Quiet Series™ | MotionMax™ | SuperSOT™-6 | UniFET™ |
| FACT® | Motion-SPM™ | SuperSOT™-8 | VcX™ |
| FAST® | mWSaver™ | SupreMOS® | VisualMax™ |
| FastvCore™ | OptoHiT™ | SyncFET™ | VoltagePlus™ |
| FETBench™ | OPTOLOGIC® | Sync-Lock™ | XS™ |
| FlashWriter®* | OPTOPLANAR® |  SYSTEM GENERAL®* | |
| FPS™ | | | |

* Trademarks of System General Corporation, used under license by Fairchild Semiconductor.

DISCLAIMER

FAIRCHILD SEMICONDUCTOR RESERVES THE RIGHT TO MAKE CHANGES WITHOUT FURTHER NOTICE TO ANY PRODUCTS HEREIN TO IMPROVE RELIABILITY, FUNCTION, OR DESIGN. FAIRCHILD DOES NOT ASSUME ANY LIABILITY ARISING OUT OF THE APPLICATION OR USE OF ANY PRODUCT OR CIRCUIT DESCRIBED HEREIN; NEITHER DOES IT CONVEY ANY LICENSE UNDER ITS PATENT RIGHTS, NOR THE RIGHTS OF OTHERS. THESE SPECIFICATIONS DO NOT EXPAND THE TERMS OF FAIRCHILD'S WORLDWIDE TERMS AND CONDITIONS, SPECIFICALLY THE WARRANTY THEREIN, WHICH COVERS THESE PRODUCTS.

LIFE SUPPORT POLICY

FAIRCHILD'S PRODUCTS ARE NOT AUTHORIZED FOR USE AS CRITICAL COMPONENTS IN LIFE SUPPORT DEVICES OR SYSTEMS WITHOUT THE EXPRESS WRITTEN APPROVAL OF FAIRCHILD SEMICONDUCTOR CORPORATION.

As used herein:

1. Life support devices or systems are devices or systems which, (a) are intended for surgical implant into the body or (b) support or sustain life, and (c) whose failure to perform when properly used in accordance with instructions for use provided in the labeling, can be reasonably expected to result in a significant injury of the user.
2. A critical component in any component of a life support, device, or system whose failure to perform can be reasonably expected to cause the failure of the life support device or system, or to affect its safety or effectiveness.

ANTI-COUNTERFEITING POLICY

Fairchild Semiconductor Corporation's Anti-Counterfeiting Policy. Fairchild's Anti-Counterfeiting Policy is also stated on our external website, www.fairchildsemi.com, under Sales Support.

Counterfeiting of semiconductor parts is a growing problem in the industry. All manufacturers of semiconductor products are experiencing counterfeiting of their parts. Customers who inadvertently purchase counterfeit parts experience many problems such as loss of brand reputation, substandard performance, failed applications, and increased cost of production and manufacturing delays. Fairchild is taking strong measures to protect ourselves and our customers from the proliferation of counterfeit parts. Fairchild strongly encourages customers to purchase Fairchild parts either directly from Fairchild or from Authorized Fairchild Distributors who are listed by country on our web page cited above. Products customers buy either from Fairchild directly or from Authorized Fairchild Distributors are genuine parts, have full traceability, meet Fairchild's quality standards for handling and storage and provide access to Fairchild's full range of up-to-date technical and product information. Fairchild and our Authorized Distributors will stand behind all warranties and will appropriately address any warranty issues that may arise. Fairchild will not provide any warranty coverage or other assistance for parts bought from Unauthorized Sources. Fairchild is committed to combat this global problem and encourage our customers to do their part in stopping this practice by buying direct or from authorized distributors.

PRODUCT STATUS DEFINITIONS

Definition of Terms

Datasheet Identification	Product Status	Definition
Advance Information	Formative / In Design	Datasheet contains the design specifications for product development. Specifications may change in any manner without notice.
Preliminary	First Production	Datasheet contains preliminary data; supplementary data will be published at a later date. Fairchild Semiconductor reserves the right to make changes at any time without notice to improve design.
No Identification Needed	Full Production	Datasheet contains final specifications. Fairchild Semiconductor reserves the right to make changes at any time without notice to improve the design.
Obsolete	Not In Production	Datasheet contains specifications on a product that is discontinued by Fairchild Semiconductor. The datasheet is for reference information only.

Rev. I61

ON Semiconductor and  are trademarks of Semiconductor Components Industries, LLC dba ON Semiconductor or its subsidiaries in the United States and/or other countries. ON Semiconductor owns the rights to a number of patents, trademarks, copyrights, trade secrets, and other intellectual property. A listing of ON Semiconductor's product/patent coverage may be accessed at www.onsemi.com/site/pdf/Patent-Marking.pdf. ON Semiconductor reserves the right to make changes without further notice to any products herein. ON Semiconductor makes no warranty, representation or guarantee regarding the suitability of its products for any particular purpose, nor does ON Semiconductor assume any liability arising out of the application or use of any product or circuit, and specifically disclaims any and all liability, including without limitation special, consequential or incidental damages. Buyer is responsible for its products and applications using ON Semiconductor products, including compliance with all laws, regulations and safety requirements or standards, regardless of any support or applications information provided by ON Semiconductor. "Typical" parameters which may be provided in ON Semiconductor data sheets and/or specifications can and do vary in different applications and actual performance may vary over time. All operating parameters, including "Typicals" must be validated for each customer application by customer's technical experts. ON Semiconductor does not convey any license under its patent rights nor the rights of others. ON Semiconductor products are not designed, intended, or authorized for use as a critical component in life support systems or any FDA Class 3 medical devices or medical devices with a same or similar classification in a foreign jurisdiction or any devices intended for implantation in the human body. Should Buyer purchase or use ON Semiconductor products for any such unintended or unauthorized application, Buyer shall indemnify and hold ON Semiconductor and its officers, employees, subsidiaries, affiliates, and distributors harmless against all claims, costs, damages, and expenses, and reasonable attorney fees arising out of, directly or indirectly, any claim of personal injury or death associated with such unintended or unauthorized use, even if such claim alleges that ON Semiconductor was negligent regarding the design or manufacture of the part. ON Semiconductor is an Equal Opportunity/Affirmative Action Employer. This literature is subject to all applicable copyright laws and is not for resale in any manner.

PUBLICATION ORDERING INFORMATION

LITERATURE FULFILLMENT:

Literature Distribution Center for ON Semiconductor
19521 E. 32nd Pkwy, Aurora, Colorado 80011 USA
Phone: 303-675-2175 or 800-344-3860 Toll Free USA/Canada
Fax: 303-675-2176 or 800-344-3867 Toll Free USA/Canada
Email: orderlit@onsemi.com

N. American Technical Support: 800-282-9855 Toll Free
USA/Canada
Europe, Middle East and Africa Technical Support:
Phone: 421 33 790 2910
Japan Customer Focus Center
Phone: 81-3-5817-1050

ON Semiconductor Website: www.onsemi.com
Order Literature: <http://www.onsemi.com/orderlit>
For additional information, please contact your local
Sales Representative

Mouser Electronics

Authorized Distributor

Click to View Pricing, Inventory, Delivery & Lifecycle Information:

[ON Semiconductor:](#)

[FSUSB74MPX](#) [FSUSB74UMX](#)

Компания «Океан Электроники» предлагает заключение долгосрочных отношений при поставках импортных электронных компонентов на взаимовыгодных условиях!

Наши преимущества:

- Поставка оригинальных импортных электронных компонентов напрямую с производств Америки, Европы и Азии, а так же с крупнейших складов мира;
- Широкая линейка поставок активных и пассивных импортных электронных компонентов (более 30 млн. наименований);
- Поставка сложных, дефицитных, либо снятых с производства позиций;
- Оперативные сроки поставки под заказ (от 5 рабочих дней);
- Экспресс доставка в любую точку России;
- Помощь Конструкторского Отдела и консультации квалифицированных инженеров;
- Техническая поддержка проекта, помощь в подборе аналогов, поставка прототипов;
- Поставка электронных компонентов под контролем ВП;
- Система менеджмента качества сертифицирована по Международному стандарту ISO 9001;
- При необходимости вся продукция военного и аэрокосмического назначения проходит испытания и сертификацию в лаборатории (по согласованию с заказчиком);
- Поставка специализированных компонентов военного и аэрокосмического уровня качества (Xilinx, Altera, Analog Devices, Intersil, Interpoint, Microsemi, Actel, Aeroflex, Peregrine, VPT, Syfer, Eurofarad, Texas Instruments, MS Kennedy, Miteq, Cobham, E2V, MA-COM, Hittite, Mini-Circuits, General Dynamics и др.);

Компания «Океан Электроники» является официальным дистрибьютором и эксклюзивным представителем в России одного из крупнейших производителей разъемов военного и аэрокосмического назначения «JONHON», а так же официальным дистрибьютором и эксклюзивным представителем в России производителя высокотехнологичных и надежных решений для передачи СВЧ сигналов «FORSTAR».



JONHON

«JONHON» (основан в 1970 г.)

Разъемы специального, военного и аэрокосмического назначения:

(Применяются в военной, авиационной, аэрокосмической, морской, железнодорожной, горно- и нефтедобывающей отраслях промышленности)

«FORSTAR» (основан в 1998 г.)

ВЧ соединители, коаксиальные кабели, кабельные сборки и микроволновые компоненты:

(Применяются в телекоммуникациях гражданского и специального назначения, в средствах связи, РЛС, а так же военной, авиационной и аэрокосмической отраслях промышленности).



Телефон: 8 (812) 309-75-97 (многоканальный)

Факс: 8 (812) 320-03-32

Электронная почта: ocean@oceanchips.ru

Web: <http://oceanchips.ru/>

Адрес: 198099, г. Санкт-Петербург, ул. Калинина, д. 2, корп. 4, лит. А