

TFA32 Series

Automotive Grade Tuning Fork Crystal

Features

- AEC-Q200 Compliant
- Hermetic Ceramic Surface Mount Package
- Tuning Fork Crystal Design
- 32.7680kHz Frequency Reference
- Frequency Tolerance, ± 20 ppm Standard
- Parabolic Temperature Coefficient
- Tape and Reel Packaging, EIA-418

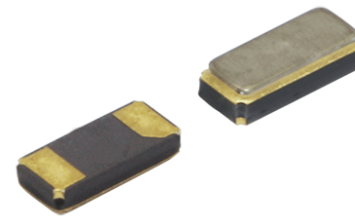

Part Dimensions:
3.2 x 1.5 x 0.9mm • 12.1467mg

Applications

- Automotive Electronics
- Car Navigation Systems
- Car Infotainment Systems
- Industrial Control Equipment
- M2M Communications
- FPGAs & Microcontrollers

Description

CTS TFA32 Series is ideal for supporting wide range of electronic designs requiring a Real Time Clock reference. This series will support general automotive and industrial applications.

Ordering Information

Model		Frequency Tolerance	Load Capacitance	Temperature Range	Frequency Code [kHz]	Packaging																																	
TF	A32	2	P	I	327K	R																																	
<table border="1"> <thead> <tr> <th>Code</th> <th>Package</th> </tr> </thead> <tbody> <tr> <td>A</td> <td>Automotive</td> </tr> <tr> <td>32</td> <td>3.2x1.5mm</td> </tr> </tbody> </table>		Code	Package	A	Automotive	32	3.2x1.5mm	<table border="1"> <thead> <tr> <th>Code</th> <th>Capacitance</th> </tr> </thead> <tbody> <tr> <td>P</td> <td>12.5pF</td> </tr> <tr> <td>J</td> <td>9pF</td> </tr> <tr> <td>V</td> <td>7pF</td> </tr> <tr> <td>T</td> <td>6pF</td> </tr> </tbody> </table>		Code	Capacitance	P	12.5pF	J	9pF	V	7pF	T	6pF	<table border="1"> <thead> <tr> <th>Code</th> <th>Temp. Range</th> </tr> </thead> <tbody> <tr> <td>I</td> <td>-40°C to +85°C</td> </tr> <tr> <td>G</td> <td>-40°C to +105°C</td> </tr> <tr> <td>H</td> <td>-40°C to +125°C¹</td> </tr> </tbody> </table>		Code	Temp. Range	I	-40°C to +85°C	G	-40°C to +105°C	H	-40°C to +125°C ¹	<table border="1"> <thead> <tr> <th>Code</th> <th>Frequency</th> </tr> </thead> <tbody> <tr> <td>327K</td> <td>Frequency = 32.7680kHz</td> </tr> </tbody> </table>	Code	Frequency	327K	Frequency = 32.7680kHz	<table border="1"> <thead> <tr> <th>Code</th> <th>Packing</th> </tr> </thead> <tbody> <tr> <td>R</td> <td>3k pcs./reel</td> </tr> </tbody> </table>	Code	Packing	R	3k pcs./reel
Code	Package																																						
A	Automotive																																						
32	3.2x1.5mm																																						
Code	Capacitance																																						
P	12.5pF																																						
J	9pF																																						
V	7pF																																						
T	6pF																																						
Code	Temp. Range																																						
I	-40°C to +85°C																																						
G	-40°C to +105°C																																						
H	-40°C to +125°C ¹																																						
Code	Frequency																																						
327K	Frequency = 32.7680kHz																																						
Code	Packing																																						
R	3k pcs./reel																																						
<table border="1"> <thead> <tr> <th>Code</th> <th>@ +25°C</th> </tr> </thead> <tbody> <tr> <td>2</td> <td>± 20ppm</td> </tr> <tr> <td>1</td> <td>± 10ppm</td> </tr> </tbody> </table>		Code	@ +25°C	2	± 20 ppm	1	± 10 ppm																																
Code	@ +25°C																																						
2	± 20 ppm																																						
1	± 10 ppm																																						

Notes:

1] Check with factory for availability.

**Not all performance combinations and frequencies may be available.
Contact your local CTS Representative or CTS Customer Service for availability.**

This product is specified for use only in standard commercial applications. Supplier disclaims all express and implied warranties and liability in connection with any use of this product in any non-commercial applications or in any application that may expose the product to conditions that are outside of the tolerances provided in its specification.

Electrical Specifications

Operating Conditions

PARAMETER	SYMBOL	CONDITIONS	MIN	TYP	MAX	UNIT
Operating Temperature	T_A	-	-40	+25	+105	°C
Turnover Temperature	T_M	-	+20	+25	+30	°C
Storage Temperature	T_{STG}	-	-55	-	+125	°C

Frequency Stability

PARAMETER	SYMBOL	CONDITIONS	MIN	TYP	MAX	UNIT
Frequency	f_0	-		32.7680		kHz
Frequency Tolerance [Note 1]	$\Delta f/f_0$	Standard @ +25°C	-20	-	20	ppm
Parabolic Coefficient	β	See Figure 1		-0.034 ±0.010		ppm/°C ²
Aging	$\Delta f/f_0$	First Year @ +25°C	-3	-	3	ppm

Crystal Parameters

PARAMETER	SYMBOL	CONDITIONS	MIN	TYP	MAX	UNIT
Operating Mode	-	-		Flexural Mode [Tuning Fork]		-
Load Capacitance [Note 1]	C_L	Standard	-	12.5	-	pF
Shunt Capacitance	C_0	-	-	1.2	-	pF
Motional Capacitance	C_1	-	-	3.4	-	fF
Series Resistance	R_1	-	-	-	70	kΩ
Drive Level	DL	-	-	0.5	1.0	μW
Insulation Resistance	R_i	+100Vdc ±15Vdc	500	-	-	MΩ

1.] See Ordering Information for available options.

Figure 1

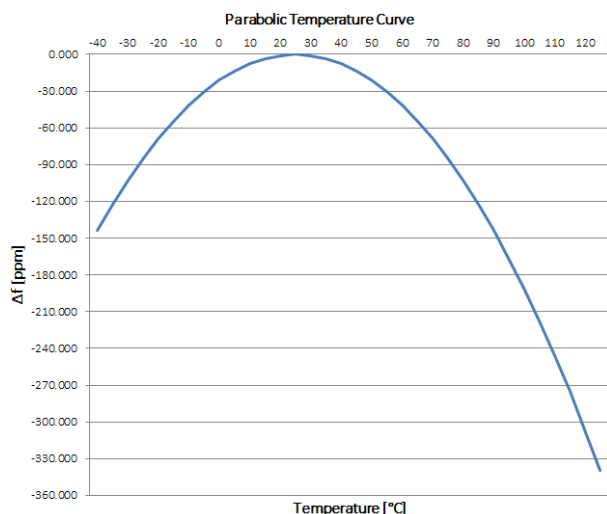

Frequency Stability [Δf] at a given temperature,

$$\Delta f = \beta [T_A - T_M]^2$$

β = Parabolic Coefficient
 T_A = Ambient Temperature
 T_M = Turnover Temperature

Ex. Find frequency stability at $T_A = +60^\circ\text{C}$
 $\Delta f = -0.034[60-25]^2$
 $\Delta f = -0.034[35]^2$
 $\Delta f = -41.65\text{ppm}$

Mechanical Specifications

Package Drawing

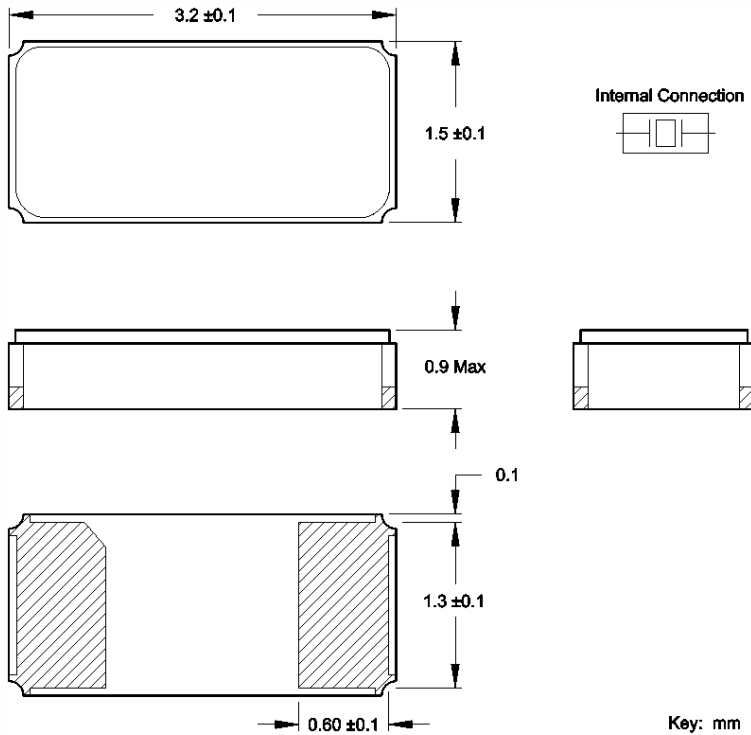

Marking Information

Refer to document 016-0071-0, TF Marking Guide, for marking formats by product family.

Recommended Pad Layout

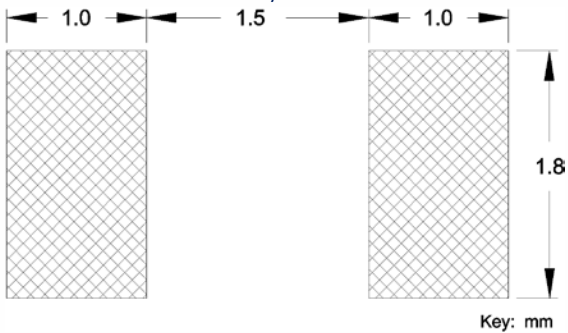

Notes

1. JEDEC termination code (e4). Barrier-plating is nickel [Ni] with gold [Au] flash plate.
2. Reflow conditions per JEDEC J-STD-020; +260°C maximum, 20 seconds.
3. MSL = 1.

Packaging - Tape and Reel

Tape Drawing

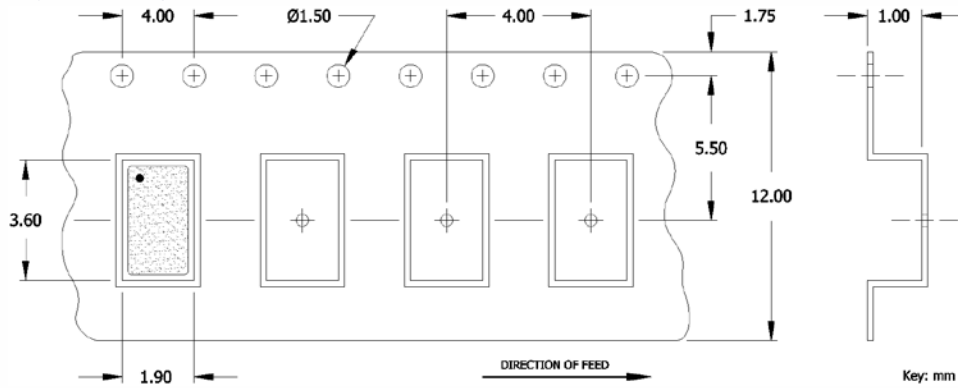

Reel Drawing

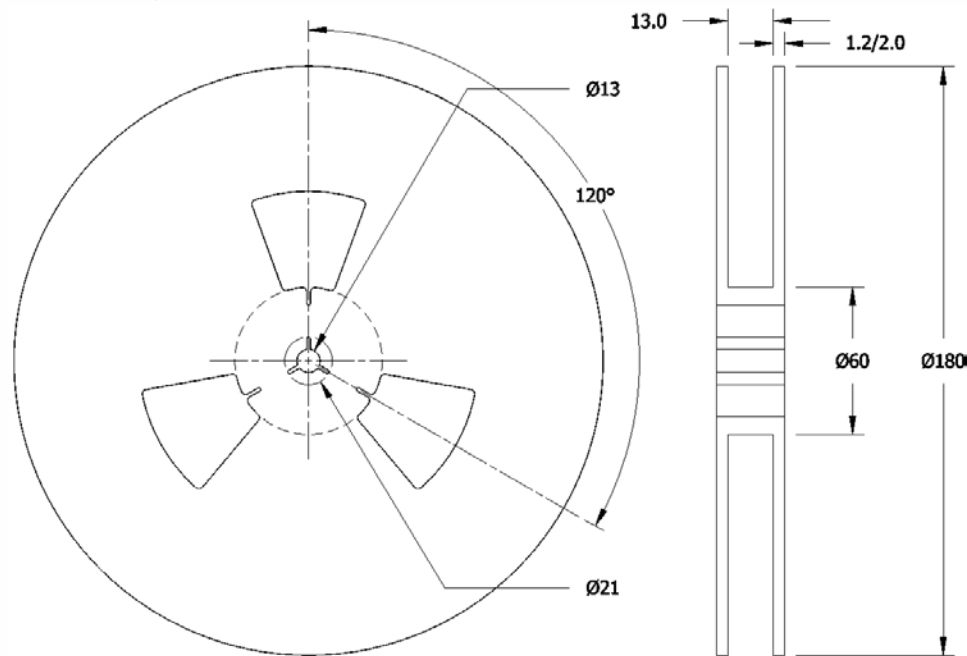

Notes

1. Device quantity is 3k pieces maximum per 180mm reel.
2. Complete CTS part number, frequency value, date code and manufacturing site code information must appear on reel and carton labels.

Компания «Океан Электроники» предлагает заключение долгосрочных отношений при поставках импортных электронных компонентов на взаимовыгодных условиях!

Наши преимущества:

- Поставка оригинальных импортных электронных компонентов напрямую с производств Америки, Европы и Азии, а так же с крупнейших складов мира;
- Широкая линейка поставок активных и пассивных импортных электронных компонентов (более 30 млн. наименований);
- Поставка сложных, дефицитных, либо снятых с производства позиций;
- Оперативные сроки поставки под заказ (от 5 рабочих дней);
- Экспресс доставка в любую точку России;
- Помощь Конструкторского Отдела и консультации квалифицированных инженеров;
- Техническая поддержка проекта, помощь в подборе аналогов, поставка прототипов;
- Поставка электронных компонентов под контролем ВП;
- Система менеджмента качества сертифицирована по Международному стандарту ISO 9001;
- При необходимости вся продукция военного и аэрокосмического назначения проходит испытания и сертификацию в лаборатории (по согласованию с заказчиком);
- Поставка специализированных компонентов военного и аэрокосмического уровня качества (Xilinx, Altera, Analog Devices, Intersil, Interpoint, Microsemi, Actel, Aeroflex, Peregrine, VPT, Syfer, Eurofarad, Texas Instruments, MS Kennedy, Miteq, Cobham, E2V, MA-COM, Hittite, Mini-Circuits, General Dynamics и др.);

Компания «Океан Электроники» является официальным дистрибьютором и эксклюзивным представителем в России одного из крупнейших производителей разъемов военного и аэрокосмического назначения «JONHON», а так же официальным дистрибьютором и эксклюзивным представителем в России производителя высокотехнологичных и надежных решений для передачи СВЧ сигналов «FORSTAR».



JONHON

«JONHON» (основан в 1970 г.)

Разъемы специального, военного и аэрокосмического назначения:

(Применяются в военной, авиационной, аэрокосмической, морской, железнодорожной, горно- и нефтедобывающей отраслях промышленности)

«FORSTAR» (основан в 1998 г.)

ВЧ соединители, коаксиальные кабели, кабельные сборки и микроволновые компоненты:

(Применяются в телекоммуникациях гражданского и специального назначения, в средствах связи, РЛС, а так же военной, авиационной и аэрокосмической отраслях промышленности).



Телефон: 8 (812) 309-75-97 (многоканальный)

Факс: 8 (812) 320-03-32

Электронная почта: ocean@oceanchips.ru

Web: <http://oceanchips.ru/>

Адрес: 198099, г. Санкт-Петербург, ул. Калинина, д. 2, корп. 4, лит. А