

## EMC1187

# Triple Channel 1°C Temperature Sensor with Hardware Thermal Shutdown and 1.8V SMBus Communications

### PRODUCT FEATURES

Datasheet

#### General Description

The EMC1187 is a high accuracy, low cost, 1.8V System Management Bus (SMBus) compatible temperature sensor. Advanced features such as Resistance Error Correction (REC), Beta Compensation (to support CPU diodes requiring the BJT/transistor model including 65nm and lower geometry processors) and automatic diode type detection combine to provide a robust solution for complex environmental monitoring applications. The ability to communicate at 1.8V SMBus levels provides compatible I/O for the advanced processors found in today's tablet and smartphone applications.

The EMC1187 monitors three temperature channels (two external and one internal), providing  $\pm 1^\circ\text{C}$  accuracy for both external and internal diode temperatures.

Additionally, the EMC1187 provides a hardware programmable system shutdown feature that is programmed at part power-up via two pull-up resistor values and that cannot be masked or corrupted through the SMBus.

REC automatically eliminates the temperature error caused by series resistance allowing greater flexibility in routing thermal diodes. Frequency hopping\* and analog filters ensure remote diode traces can be as far as eight (8) inches without degrading the signal. Beta Compensation eliminates temperature errors caused by low, variable beta transistors common in today's fine geometry processors. The automatic beta detection feature monitors the external diode/transistor and determines the optimum sensor settings for accurate temperature measurements regardless of processor technology. This frees the user from providing unique sensor configurations for each temperature monitoring application. These advanced features plus  $\pm 1^\circ\text{C}$  measurement accuracy provide a low-cost, highly flexible and accurate solution for critical temperature monitoring applications.

#### Applications

- Notebook Computers
- Desktop Computers
- Industrial
- Embedded applications

#### Features

- **Hardware Thermal Shutdown**
  - triggers dedicated SYS\_SHDN pin
  - hardware configured range  $77^\circ\text{C}$  to  $112^\circ\text{C}$  in  $1^\circ\text{C}$  steps
  - cannot be disabled or modified by software
- Support for diodes requiring the BJT/transistor model
  - Supports 65nm and lower geometry CPU thermal diodes
- Pin and register compatible with EMC1423
- Automatically determines external diode type and optimal settings
- Resistance Error Correction
- Frequency hops the remote sample frequency to reject DC converter and other coherent noise sources\*
- Consecutive Alert queue to further reduce false Alerts
- Up to 2 External Temperature Monitor
  - $25^\circ\text{C}$  typ,  $\pm 1^\circ\text{C}$  max accuracy ( $20^\circ\text{C} < T_{\text{DIODE}} < 110^\circ\text{C}$ )
  - $0.125^\circ\text{C}$  resolution
  - Supports up to 2.2nF diode filter capacitor
- Internal Temperature Monitor
  - $\pm 1^\circ\text{C}$  accuracy
  - $0.125^\circ\text{C}$  resolution
- 3.3V Supply Voltage
- 1.8V SMBus operation
- Programmable temperature limits for ALERT ( $85^\circ\text{C}$  default high limit and  $0^\circ\text{C}$  default low limit)
- Available in small 10-pin 3mm x 3mm DFN RoHS compliant package

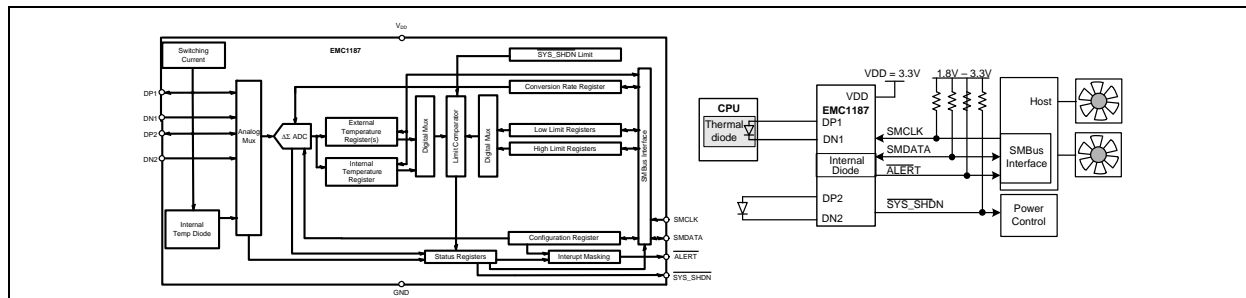

\* Technology covered under the US patent 7,193,543.

**Ordering Information:**

<b>ORDERING NUMBER</b>	<b>PACKAGE</b>	<b>FEATURES</b>	<b>SMBUS ADDRESS</b>
EMC1187-1-AIA-TR	10-pin DFN 3mm x 3mm (RoHS compliant)	Up to three temperature sensors, hardware set system shutdown, $\overline{\text{ALERT}}$ and $\overline{\text{SYS\_SHDN}}$ pins, fixed SMBus address	1001_1100( $\overline{\text{r/w}}$ )

**This product meets the halogen maximum concentration values per IEC61249-2-21**

**For RoHS compliance and environmental information, please visit [www.smcs.com/rohs](http://www.smcs.com/rohs)**

*Please contact your SMSC sales representative for additional documentation related to this product such as application notes, anomaly sheets, and design guidelines.*

Copyright © 2013 SMSC or its subsidiaries. All rights reserved.

Circuit diagrams and other information relating to SMSC products are included as a means of illustrating typical applications. Consequently, complete information sufficient for construction purposes is not necessarily given. Although the information has been checked and is believed to be accurate, no responsibility is assumed for inaccuracies. SMSC reserves the right to make changes to specifications and product descriptions at any time without notice. Contact your local SMSC sales office to obtain the latest specifications before placing your product order. The provision of this information does not convey to the purchaser of the described semiconductor devices any licenses under any patent rights or other intellectual property rights of SMSC or others. All sales are expressly conditional on your agreement to the terms and conditions of the most recently dated version of SMSC's standard Terms of Sale Agreement dated before the date of your order (the "Terms of Sale Agreement"). The product may contain design defects or errors known as anomalies which may cause the product's functions to deviate from published specifications. Anomaly sheets are available upon request. SMSC products are not designed, intended, authorized or warranted for use in any life support or other application where product failure could cause or contribute to personal injury or severe property damage. Any and all such uses without prior written approval of an Officer of SMSC and further testing and/or modification will be fully at the risk of the customer. Copies of this document or other SMSC literature, as well as the Terms of Sale Agreement, may be obtained by visiting SMSC's website at <http://www.smcs.com>. SMSC is a registered trademark of Standard Microsystems Corporation ("SMSC"). Product names and company names are the trademarks of their respective holders.

The Microchip name and logo, and the Microchip logo are registered trademarks of Microchip Technology Incorporated in the U.S.A. and other countries.

**SMSC DISCLAIMS AND EXCLUDES ANY AND ALL WARRANTIES, INCLUDING WITHOUT LIMITATION ANY AND ALL IMPLIED WARRANTIES OF MERCHANTABILITY, FITNESS FOR A PARTICULAR PURPOSE, TITLE, AND AGAINST INFRINGEMENT AND THE LIKE, AND ANY AND ALL WARRANTIES ARISING FROM ANY COURSE OF DEALING OR USAGE OF TRADE. IN NO EVENT SHALL SMSC BE LIABLE FOR ANY DIRECT, INCIDENTAL, INDIRECT, SPECIAL, PUNITIVE, OR CONSEQUENTIAL DAMAGES; OR FOR LOST DATA, PROFITS, SAVINGS OR REVENUES OF ANY KIND; REGARDLESS OF THE FORM OF ACTION, WHETHER BASED ON CONTRACT; TORT; NEGLIGENCE OF SMSC OR OTHERS; STRICT LIABILITY; BREACH OF WARRANTY; OR OTHERWISE; WHETHER OR NOT ANY REMEDY OF BUYER IS HELD TO HAVE FAILED OF ITS ESSENTIAL PURPOSE, AND WHETHER OR NOT SMSC HAS BEEN ADVISED OF THE POSSIBILITY OF SUCH DAMAGES.**

## Table of Contents

<b>Chapter 1 Block Diagram</b> .....	<b>7</b>
<b>Chapter 2 Pin Description</b> .....	<b>8</b>
<b>Chapter 3 Electrical Specifications</b> .....	<b>10</b>
3.1 Absolute Maximum Ratings .....	10
3.2 Electrical Specifications .....	10
3.3 SMBus Electrical Characteristics .....	11
<b>Chapter 4 System Management Bus Interface Protocol</b> .....	<b>13</b>
4.1 Communications Protocol .....	13
4.1.1 SMBus Start Bit .....	13
4.1.2 SMBus Address and RD / WR Bit .....	13
4.1.3 SMBus Data Bytes .....	13
4.1.4 SMBus ACK and NACK Bits .....	13
4.1.5 SMBus Stop Bit .....	14
4.1.6 SMBus Timeout .....	14
4.1.7 SMBus and I <sup>2</sup> C Compatibility .....	14
4.2 SMBus Protocols .....	14
4.2.1 Write Byte .....	15
4.2.2 Read Byte .....	15
4.2.3 Send Byte .....	15
4.2.4 Receive Byte .....	15
4.3 Alert Response Address .....	16
<b>Chapter 5 Product Description</b> .....	<b>17</b>
5.1 Conversion Rates .....	17
5.2 Dynamic Averaging .....	17
5.3 .SYS_SHDN Output .....	18
5.4 Hardware Thermal Shutdown Limit .....	19
5.5 ALERT Output .....	20
5.5.1 ALERT Pin Interrupt Mode .....	20
5.5.2 ALERT Pin Comparator Mode .....	20
5.6 ALERT and SYS_SHDN Pin Considerations .....	20
5.7 Temperature Measurement .....	21
5.7.1 Beta Compensation .....	21
5.7.2 Resistance Error Correction (REC) .....	21
5.7.3 Programmable External Diode Ideality Factor .....	22
5.8 Diode Faults .....	22
5.9 Consecutive Alerts .....	22
5.10 Digital Filter .....	22
5.11 Temperature Measurement Results and Data .....	24
<b>Chapter 6 Register Description</b> .....	<b>25</b>
6.1 Data Read Interlock .....	28
6.2 Temperature Data Registers .....	28
6.3 Status Register 02h .....	28
6.4 Configuration Register 03h / 09h .....	29

6.5 Conversion Rate Register 04h / 0Ah . . . . .	30
6.6 Limit Registers . . . . .	31
6.7 Scratchpad Registers 11h and 12h . . . . .	32
6.8 Therm Limit Registers . . . . .	33
6.9 External Diode Fault Register 1Bh . . . . .	33
6.10 Software Thermal Shutdown Configuration Register 1Dh . . . . .	33
6.11 Hardware Thermal Shutdown Limit Register 1Eh . . . . .	34
6.12 Channel Mask Register 1Fh . . . . .	35
6.13 Consecutive ALERT Register 22h . . . . .	35
6.14 Beta Configuration Registers 25h and 26h . . . . .	37
6.15 External Diode Ideality Factor Register 27h . . . . .	38
6.16 High Limit Status Register 35h . . . . .	40
6.17 Low Limit Status Register 36h . . . . .	40
6.18 Therm Limit Status Register 37h . . . . .	41
6.19 Filter Control Register 40h . . . . .	41
6.20 Product ID Register . . . . .	42
6.21 SMSC ID Register . . . . .	42
6.22 Revision Register . . . . .	42
<hr/>	
<b>Chapter 7 Typical Operating Curves . . . . .</b>	<b>43</b>
<hr/>	
<b>Chapter 8 Package Information . . . . .</b>	<b>44</b>
8.1 Package Markings . . . . .	45
<hr/>	
<b>Chapter 9 Datasheet Revision History . . . . .</b>	<b>47</b>

## List of Figures

Figure 1.1	EMC1187 Block Diagram . . . . .	7
Figure 2.1	EMC1187 Pin Diagram DFN-10 . . . . .	8
Figure 4.1	SMBus Timing Diagram . . . . .	13
Figure 5.1	System Diagram for EMC1187 . . . . .	17
Figure 5.2	Block Diagram of Hardware Thermal Shutdown . . . . .	19
Figure 5.3	Isolating ALERT and SYS_SHDN Pin . . . . .	21
Figure 5.4	Temperature Filter Step Response . . . . .	23
Figure 5.5	Temperature Filter Impulse Response . . . . .	23
Figure 8.1	10-Pin DFN Package Drawing . . . . .	44
Figure 8.2	10-Pin DFN Package Dimensions . . . . .	45
Figure 8.3	10 Pin DFN PCB Footprint . . . . .	45
Figure 8.4	EMC1187-1 10-Pin DFN Package Markings . . . . .	46

## List of Tables

Table 2.1	EMC1187 Pin Description	8
Table 2.2	Pin Types	9
Table 3.1	Absolute Maximum Ratings	10
Table 3.2	Electrical Specifications	10
Table 3.3	SMBus Electrical Specifications	11
Table 4.1	Protocol Format	14
Table 4.2	Write Byte Protocol	15
Table 4.3	Read Byte Protocol	15
Table 4.4	Send Byte Protocol	15
Table 4.5	Receive Byte Protocol	15
Table 4.6	Alert Response Address Protocol	16
Table 5.1	Supply Current vs. Conversion Rate for EMC1187	18
Table 5.2	SYS_SHDN Threshold Temperature	19
Table 5.3	Temperature Data Format	24
Table 6.1	Register Set in Hexadecimal Order	25
Table 6.2	Temperature Data Registers	28
Table 6.3	Status Register	28
Table 6.4	Configuration Register	29
Table 6.5	Conversion Rate Register	30
Table 6.6	Conversion Rate	30
Table 6.7	Temperature Limit Registers	31
Table 6.8	Scratchpad Register	32
Table 6.9	Therm Limit Registers	33
Table 6.10	External Diode Fault Register	33
Table 6.11	Software Thermal Shutdown Configuration Register	33
Table 6.12	Hardware Thermal Shutdown Limit Register	34
Table 6.13	Channel Mask Register	35
Table 6.14	Consecutive ALERT Register	35
Table 6.15	Consecutive Alert / Therm Settings	37
Table 6.16	Beta Configuration Register	37
Table 6.17	CPU Beta Values	37
Table 6.18	Ideality Configuration Registers	38
Table 6.19	Ideality Factor Look-Up Table (Diode Model)	38
Table 6.20	Substrate Diode Ideality Factor Look-Up Table (BJT Model)	39
Table 6.21	High Limit Status Register	40
Table 6.22	Low Limit Status Register	40
Table 6.23	Therm Limit Status Register	41
Table 6.24	Filter Configuration Register	41
Table 6.25	FILTER Decode	42
Table 6.26	Product ID Register	42
Table 6.27	Manufacturer ID Register	42
Table 6.28	Revision Register	42
Table 9.1	Customer Revision History	47

# Chapter 1 Block Diagram

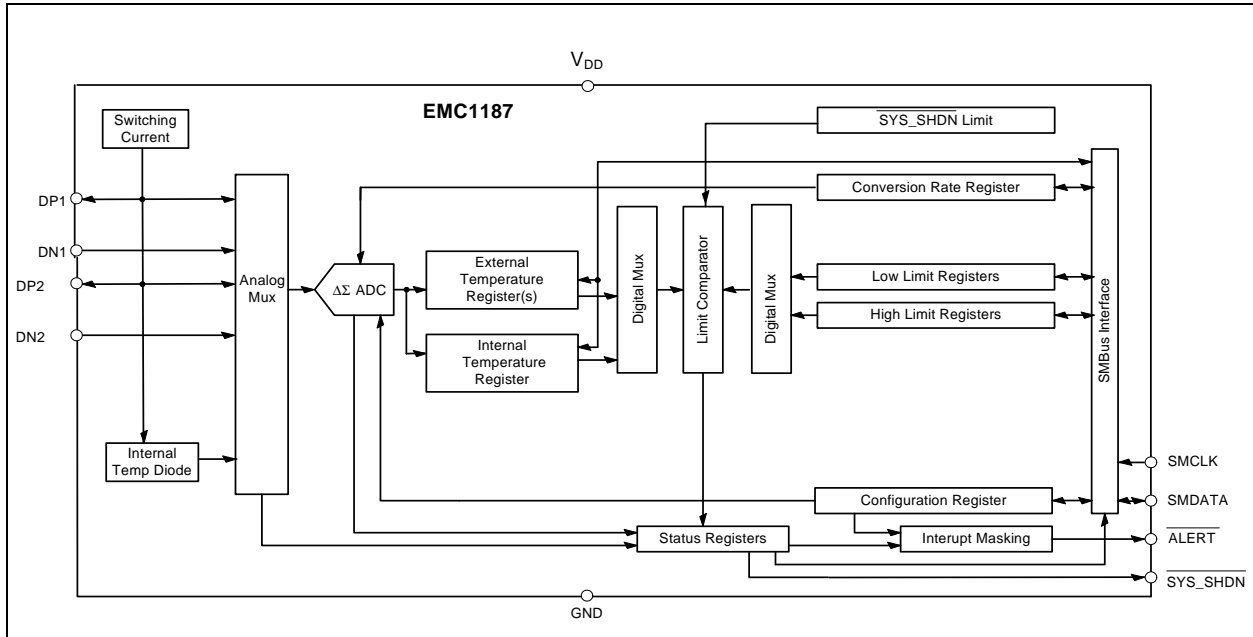

Figure 1.1 EMC1187 Block Diagram

## Chapter 2 Pin Description

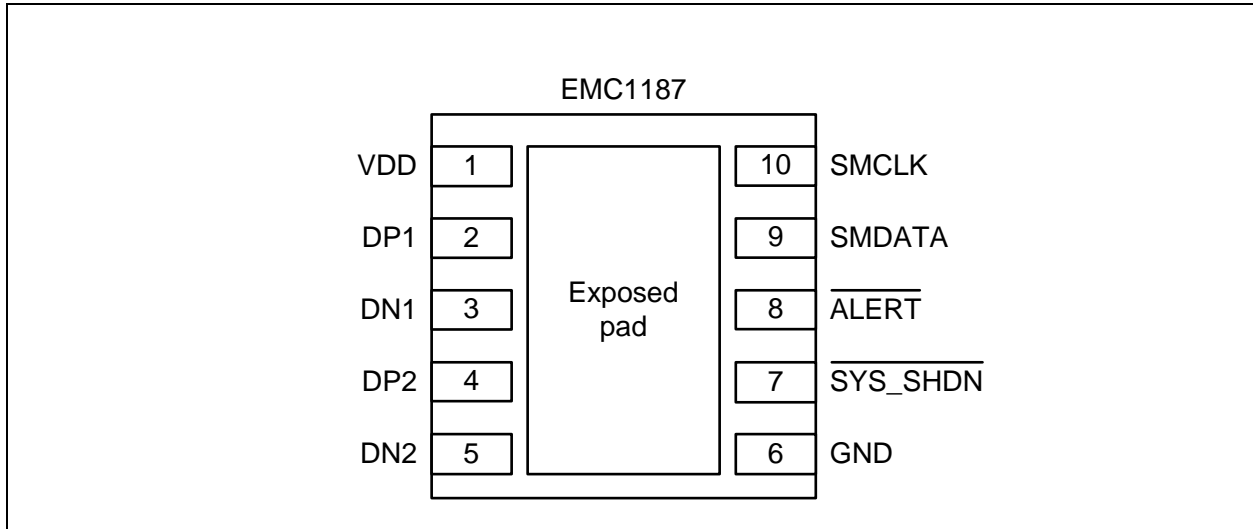

Figure 2.1 EMC1187 Pin Diagram DFN-10

Table 2.1 EMC1187 Pin Description

PIN NUMBER	NAME	FUNCTION	TYPE
1	VDD	Power supply	Power
2	DP1	External diode 1 positive (anode) connection	AIO
3	DN1	External diode 1 negative (cathode) connection	AIO
4	DP2 / DN3	External diode 2 positive (anode) connection / External Diode 3 negative (cathode) connection for anti-parallel diodes	AIO
5	DN2 / DP3	External diode 2 negative (cathode) connection / External Diode 3 positive (anode) connection for anti-parallel diodes	AIO
6	GND	Ground	Power
7	$\overline{\text{SYS\_SHDN}}$	Active low system shutdown output signal - requires pull-up resistor which selects the Hardware Thermal Shutdown Limit	OD (5V)
8	$\overline{\text{ALERT}}$	Active low digital $\overline{\text{ALERT}}$ output signal - requires pull-up resist	OD (5V)
9	SMDATA	SMBus Data input/output - requires pull-up resistor	DIOD (5V)



**Table 2.1 EMC1187 Pin Description (continued)**

PIN NUMBER	NAME	FUNCTION	TYPE
10	SMCLK	SMBus Clock input - requires pull-up resistor	DI (5V)
Bottom Pad	Exposed Pad	Not internally connected, but recommend grounding.	-

The pin types are described [Table 2.2](#).

**Table 2.2 Pin Types**

PIN TYPE	DESCRIPTION
Power	This pin is used to supply power or ground to the device.
AIO	Analog Input / Output -This pin is used as an I/O for analog signals.
DI	Digital Input - This pin is used as a digital input. This pin is 5V tolerant.
DIOD	Digital Input / Open Drain Output - This pin is used as a digital I/O. When it is used as an output, it is open drain and requires a pull-up resistor. This pin is 5V tolerant.
OD	Open Drain Digital Output - This pin is used as a digital output. It is open drain and requires a pull-up resistor. This pin is 5V tolerant.

## Chapter 3 Electrical Specifications

### 3.1 Absolute Maximum Ratings

Table 3.1 Absolute Maximum Ratings

DESCRIPTION	RATING	UNIT
Supply Voltage ( $V_{DD}$ )	-0.3 to 4.0	V
Voltage on 5V tolerant pins ( $V_{5VT\_pin}$ )	-0.3 to 5.5	V
Voltage on 5V tolerant pins ( $ V_{5VT\_pin} - V_{DD} $ ) (see Note 3.1)	0 to 3.6	V
Voltage on any other pin to Ground	-0.3 to $V_{DD} + 0.3$	V
Operating Temperature Range	-40 to +125	°C
Storage Temperature Range	-55 to +150	°C
Lead Temperature Range	Refer to JEDEC Spec. J-STD-020	
ESD Rating, All pins HBM	2000	V

**Note:** Stresses at or above those listed could cause permanent damage to the device. This is a stress rating only and functional operation of the device at any other condition above those indicated in the operation sections of this specification is not implied.

**Note 3.1** For the 5V tolerant pins that have a pull-up resistor (SMCLK, SMDATA,  $\overline{\text{SYS\_SHDN}}$  and ALERT), the pull-up voltage must not exceed 3.6V when the device is unpowered.

### 3.2 Electrical Specifications

Table 3.2 Electrical Specifications

$V_{DD} = 3.0V$ to $3.6V$ , $T_A = -40^\circ C$ to $125^\circ C$ , all typical values at $T_A = 27^\circ C$ unless otherwise noted.						
CHARACTERISTIC	SYMBOL	MIN	TYP	MAX	UNITS	CONDITIONS
DC Power						
Supply Voltage	$V_{DD}$	3.0	3.3	3.6	V	
Supply Current	$I_{DD}$		200	410	$\mu A$	0.0625 conversion / sec, dynamic averaging disabled
			215	425	$\mu A$	1 conversion / sec, dynamic averaging disabled
			325	465	$\mu A$	4 conversions / sec, dynamic averaging disabled
			890	1050	$\mu A$	4 conversions / sec, dynamic averaging enabled

**Table 3.2 Electrical Specifications (continued)**

V <sub>DD</sub> = 3.0V to 3.6V, T <sub>A</sub> = -40°C to 125°C, all typical values at T <sub>A</sub> = 27°C unless otherwise noted.						
CHARACTERISTIC	SYMBOL	MIN	TYP	MAX	UNITS	CONDITIONS
			1120		μA	≥ 16 conversions / sec, dynamic averaging enabled
Internal Temperature Monitor						
Temperature Accuracy			±0.25	±1	°C	-5°C < T <sub>A</sub> < 100°C
				±2	°C	-40°C < T <sub>A</sub> < 125°C
Temperature Resolution			0.125		°C	
External Temperature Monitor						
Temperature Accuracy			±0.25	±1	°C	+20°C < T <sub>DIODE</sub> < +110°C 0°C < T <sub>A</sub> < 100°C
			±0.5	±2	°C	-40°C < T <sub>DIODE</sub> < 127°C
Temperature Resolution			0.125		°C	
Capacitive Filter	C <sub>FILTER</sub>		2.2	2.7	nF	Connected across external diode
$\overline{\text{ALERT}}$ and SYS_SHDN pins						
Output Low Voltage	V <sub>OL</sub>	0.4			V	I <sub>SINK</sub> = 8mA
Leakage Current	I <sub>LEAK</sub>			±5	μA	$\overline{\text{ALERT}}$ and pins Device powered or unpowered T <sub>A</sub> < 85°C pull-up voltage ≤ 3.6V

### 3.3 SMBus Electrical Characteristics

**Table 3.3 SMBus Electrical Specifications**

V <sub>DD</sub> = 3.0 to 3.6V, T <sub>A</sub> = -40°C to 125°C, all typical values are at T <sub>A</sub> = 27°C unless otherwise noted.						
CHARACTERISTIC	SYMBOL	MIN	TYP	MAX	UNITS	CONDITIONS
SMBus Interface						
Input High Voltage	V <sub>IH</sub>	1.4		V <sub>DD</sub>	V	5V Tolerant. Voltage threshold based on 1.8V operation
Input Low Voltage	V <sub>IL</sub>	-0.3		0.8	V	5V Tolerant. Voltage threshold based on 1.8V operation
Leakage Current	I <sub>LEAK</sub>			±5	μA	Powered or unpowered T <sub>A</sub> < 85°C
Hysteresis		50			mV	
Input Capacitance	C <sub>IN</sub>		5		pF	
Output Low Sink Current	I <sub>OL</sub>	8.2		15	mA	SMDATA = 0.4V

**Table 3.3 SMBus Electrical Specifications (continued)**

V <sub>DD</sub> = 3.0 to 3.6V, T <sub>A</sub> = -40°C to 125°C, all typical values are at T <sub>A</sub> = 27°C unless otherwise noted.						
CHARACTERISTIC	SYMBOL	MIN	TYP	MAX	UNITS	CONDITIONS
SMBus Timing						
Clock Frequency	f <sub>SMB</sub>	10		400	kHz	
Spike Suppression	t <sub>SP</sub>			50	ns	
Bus Free Time Stop to Start	t <sub>BUF</sub>	1.3			μs	
Hold Time: Start	t <sub>HD:STA</sub>	0.6			μs	
Setup Time: Start	t <sub>SU:STA</sub>	0.6			μs	
Setup Time: Stop	t <sub>SU:STO</sub>	0.6			μs	
Data Hold Time	t <sub>HD:DAT</sub>	0			μs	When transmitting to the master
Data Hold Time	t <sub>HD:DAT</sub>	0.3			μs	When receiving from the master
Data Setup Time	t <sub>SU:DAT</sub>	100			ns	
Clock Low Period	t <sub>LOW</sub>	1.3			μs	
Clock High Period	t <sub>HIGH</sub>	0.6			μs	
Clock/Data Fall time	t <sub>FALL</sub>			300	ns	Min = 20+0.1C <sub>LOAD</sub> ns
Clock/Data Rise time	t <sub>RISE</sub>			300	ns	Min = 20+0.1C <sub>LOAD</sub> ns
Capacitive Load	C <sub>LOAD</sub>			400	pF	per bus line
Timeout	t <sub>TIMEOUT</sub>	25		35	ms	Disabled by default

## Chapter 4 System Management Bus Interface Protocol

### 4.1 Communications Protocol

The EMC1187 communicates with a host controller, such as an SMSC SIO, through the SMBus. The SMBus is a two-wire serial communication protocol between a computer host and its peripheral devices. A detailed timing diagram is shown in [Figure 4.1](#).

For the first 15ms after power-up the device may not respond to SMBus communications.

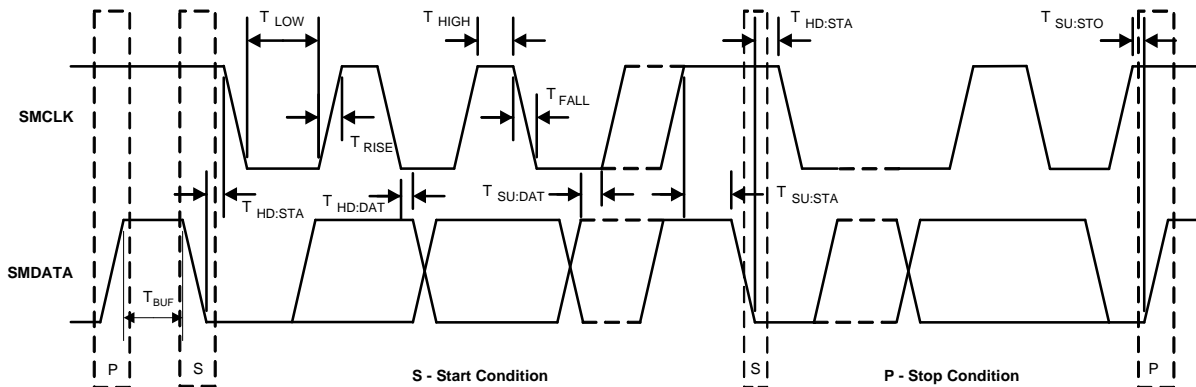

Figure 4.1 SMBus Timing Diagram

#### 4.1.1 SMBus Start Bit

The SMBus Start bit is defined as a transition of the SMBus Data line from a logic '1' state to a logic '0' state while the SMBus Clock line is in a logic '1' state.

#### 4.1.2 SMBus Address and RD / $\overline{\text{WR}}$ Bit

The SMBus Address Byte consists of the 7-bit client address followed by the RD /  $\overline{\text{WR}}$  indicator bit. If this RD /  $\overline{\text{WR}}$  bit is a logic '0', the SMBus Host is writing data to the client device. If this RD /  $\overline{\text{WR}}$  bit is a logic '1', the SMBus Host is reading data from the client device.

The EMC1187-1 SMBus address is hard coded to 1001\_1100( $r/\overline{w}$ ).

#### 4.1.3 SMBus Data Bytes

All SMBus Data bytes are sent most significant bit first and composed of 8-bits of information.

#### 4.1.4 SMBus ACK and NACK Bits

The SMBus client will acknowledge all data bytes that it receives. This is done by the client device pulling the SMBus data line low after the 8th bit of each byte that is transmitted. This applies to the Write Byte protocol.

The Host will NACK (not acknowledge) the last data byte to be received from the client by holding the SMBus data line high after the 8th data bit has been sent.

### 4.1.5 SMBus Stop Bit

The SMBus Stop bit is defined as a transition of the SMBus Data line from a logic '0' state to a logic '1' state while the SMBus clock line is in a logic '1' state. When the device detects an SMBus Stop bit and it has been communicating with the SMBus protocol, it will reset its client interface and prepare to receive further communications.

### 4.1.6 SMBus Timeout

The EMC1187 supports SMBus Timeout. If the clock line is held low for longer than  $t_{\text{TIMEOUT}}$ , the device will reset its SMBus protocol. This function can be enabled by setting the TIMEOUT bit (see [Section 6.13, "Consecutive ALERT Register 22h"](#)).

### 4.1.7 SMBus and I<sup>2</sup>C Compatibility

The EMC1187 is compatible with SMBus and I<sup>2</sup>C. The major differences between SMBus and I<sup>2</sup>C devices are highlighted here. For more information, refer to the SMBus 2.0 and I<sup>2</sup>C specifications. For information on using the EMC1187 in an I<sup>2</sup>C system, refer to SMSC AN 14.0 SMSC Dedicated Slave Devices in I<sup>2</sup>C Systems.

1. EMC1187 supports I<sup>2</sup>C fast mode at 400kHz. This covers the SMBus max time of 100kHz.
2. Minimum frequency for SMBus communications is 10kHz.
3. The SMBus client protocol will reset if the clock is held at a logic '0' for longer than 30ms. This timeout functionality is disabled by default in the EMC1187 and can be enabled by writing to the TIMEOUT bit. I<sup>2</sup>C does not have a timeout.
4. I<sup>2</sup>C devices do not support the Alert Response Address functionality (which is optional for SMBus).

Attempting to communicate with the EMC1187 SMBus interface with an invalid slave address or invalid protocol will result in no response from the device and will not affect its register contents. Stretching of the SMCLK signal is supported, provided other devices on the SMBus control the timing.

## 4.2 SMBus Protocols

The device supports Send Byte, Read Byte, Write Byte, Receive Byte, and the Alert Response Address as valid protocols as shown below.

All of the below protocols use the convention in [Table 4.1](#).

**Table 4.1 Protocol Format**

DATA SENT TO DEVICE	DATA SENT TO THE HOST
# of bits sent	# of bits sent

### 4.2.1 Write Byte

The Write Byte is used to write one byte of data to the registers, as shown in [Table 4.2](#).

**Table 4.2 Write Byte Protocol**

START	SLAVE ADDRESS	WR	ACK	REGISTER ADDRESS	ACK	REGISTER DATA	ACK	STOP
1 -> 0	YYYY_YYY	0	0	XXh	0	XXh	0	0 -> 1

### 4.2.2 Read Byte

The Read Byte protocol is used to read one byte of data from the registers as shown in [Table 4.3](#).

**Table 4.3 Read Byte Protocol**

START	SLAVE ADDRESS	WR	ACK	REGISTER ADDRESS	ACK	START	SLAVE ADDRESS	RD	ACK	REGISTER DATA	NACK	STOP
1 -> 0	YYYY_YYY	0	0	XXh	0	1 -> 0	YYYY_YYY	1	0	XX	1	0 -> 1

### 4.2.3 Send Byte

The Send Byte protocol is used to set the internal address register pointer to the correct address location. No data is transferred during the Send Byte protocol as shown in [Table 4.4](#).

**Table 4.4 Send Byte Protocol**

START	SLAVE ADDRESS	WR	ACK	REGISTER ADDRESS	ACK	STOP
1 -> 0	YYYY_YYY	0	0	XXh	0	0 -> 1

### 4.2.4 Receive Byte

The Receive Byte protocol is used to read data from a register when the internal register address pointer is known to be at the right location (e.g. set via Send Byte). This is used for consecutive reads of the same register as shown in [Table 4.5](#).

**Table 4.5 Receive Byte Protocol**

START	SLAVE ADDRESS	RD	ACK	REGISTER DATA	NACK	STOP
1 -> 0	YYYY_YYY	1	0	XXh	1	0 -> 1

### 4.3 Alert Response Address

The  $\overline{\text{ALERT}}$  output can be used as a processor interrupt or as an SMBus Alert.

When it detects that the  $\overline{\text{ALERT}}$  pin is asserted, the host will send the Alert Response Address (ARA) to the general address of 0001\_100xb. All devices with active interrupts will respond with their client address as shown in [Table 4.6](#).

**Table 4.6 Alert Response Address Protocol**

START	ALERT RESPONSE ADDRESS	RD	ACK	DEVICE ADDRESS	NACK	STOP
1 -> 0	0001_100	1	0	YYYY_YYY	1	0 -> 1

The EMC1187 will respond to the ARA in the following way:

1. Send Slave Address and verify that full slave address was sent (i.e. the SMBus communication from the device was not prematurely stopped due to a bus contention event).
2. Set the MASK\_ALL bit to clear the  $\overline{\text{ALERT}}$  pin.

**APPLICATION NOTE:** The ARA does not clear the Status Register and if the MASK\_ALL bit is cleared prior to the Status Register being cleared, the  $\overline{\text{ALERT}}$  pin will be reasserted.



## Chapter 5 Product Description

The EMC1187 is an SMBus temperature sensor with Hardware Thermal Shutdown. The EMC1187 monitors one internal diode and up to two externally connected temperature diodes.

Thermal management is performed in cooperation with a host device. This consists of the host reading the temperature data of both the external and internal temperature diodes of the EMC1187 and using that data to control the speed of one or more fans.

The EMC1187 has two levels of monitoring. The first provides a maskable  $\overline{\text{ALERT}}$  signal to the host when the measured temperatures exceed user programmable limits. This allows the EMC1187 to be used as an independent thermal watchdog to warn the host of temperature hot spots without direct control by the host. The second level of monitoring asserts the  $\overline{\text{SYS\_SHDN}}$  pin when the External Diode temperature exceeds a hardware specified threshold temperature. Additionally, the internal diode and External Diode 2 can be configured to assert the  $\overline{\text{SYS\_SHDN}}$  pin when the measured temperature exceeds user programmable limits.

For the EMC1187, the External Diode 2 channel is compatible with any diode type.

Figure 5.1 shows a system level block diagram of the EMC1187.

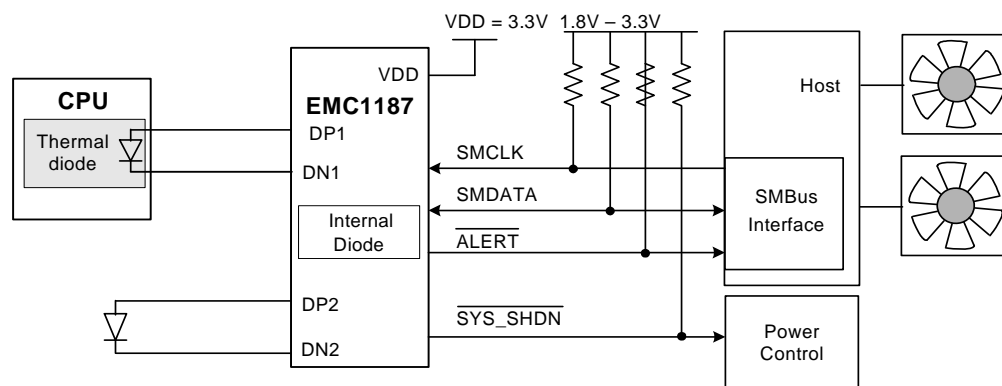

Figure 5.1 System Diagram for EMC1187

### 5.1 Conversion Rates

The EMC1187 may be configured for different conversion rates based on the system requirements. The conversion rate is configured as described in Section 6.5. The default conversion rate is 4 conversions per second. Other available conversion rates are shown in Table 6.6, "Conversion Rate".

### 5.2 Dynamic Averaging

Dynamic averaging causes the EMC1187 to measure the external diode channels for an extended time based on the selected conversion rate. This functionality can be disabled for increased power savings at the lower conversion rates (see Section 6.4, "Configuration Register 03h / 09h"). When dynamic averaging is enabled, the device will automatically adjust the sampling and measurement time for the external diode channels. This allows the device to average 2x or 16x longer than the normal 11 bit operation (nominally 21ms per channel) while still maintaining the selected conversion rate. The benefits of dynamic averaging are improved noise rejection due to the longer integration time as well as less random variation of the temperature measurement.

When enabled, the dynamic averaging applies when a one-shot command is issued. The device will perform the desired averaging during the one-shot operation according to the selected conversion rate.

When enabled, the dynamic averaging will affect the average supply current based on the chosen conversion rate as shown in [Table 5.1](#).

**Table 5.1 Supply Current vs. Conversion Rate for EMC1187**

CONVERSION RATE	AVERAGE SUPPLY CURRENT (TYPICAL)		AVERAGING FACTOR (BASED ON 11-BIT OPERATION)	
	ENABLED (DEFAULT)	DISABLED	ENABLED (DEFAULT)	DISABLED
1 / 16 sec	230uA	220uA	16x	1x
1 / 8 sec	275uA	220uA	16x	1x
1 / 4 sec	350uA	220uA	16x	1x
1 / 2 sec	405uA	220uA	16x	1x
1 / sec	480uA	250uA	8x	1x
2 / sec	850uA	290uA	4x	1x
4 / sec (default)	890uA	370uA	2x	1x
8 / sec	970uA	525uA	1x	1x
16 / sec	990uA	690uA	0.5x	0.5x
32 / sec	1030uA	1050uA	0.25x	0.25x
64 / sec	1500uA	1100uA	0.125x	0.125x

### 5.3 SYS\_SHDN Output

The SYS\_SHDN output is asserted independently of the ALERT output and cannot be masked. If the External Diode 1 temperature exceeds the Hardware Thermal Shutdown Limit for the programmed number of consecutive measurements, the SYS\_SHDN pin is asserted.

The Hardware Thermal Shutdown Limit is defined at power-up via the pull-up resistors on the SYS\_SHDN and ALERT pins as shown in [Table 5.2](#). This limit cannot be modified or masked via software.

In addition to External Diode 1 channel triggering the SYS\_SHDN pin when the measured temperature exceeds to the Hardware Thermal Shutdown Limit, each of the measurement channels can be configured to assert the SYS\_SHDN pin when they exceed the corresponding THERM Limit.

When the SYS\_SHDN pin is asserted, it will not release until the External Diode 1 temperature drops below the Hardware Thermal Shutdown Limit minus 10°C and all other measured temperatures drop below the THERM Limit minus the THERM Hysteresis value (when linked to SYS\_SHDN).

[Figure 5.2](#) shows a block diagram of the interaction between the input channels and the SYS\_SHDN pin.

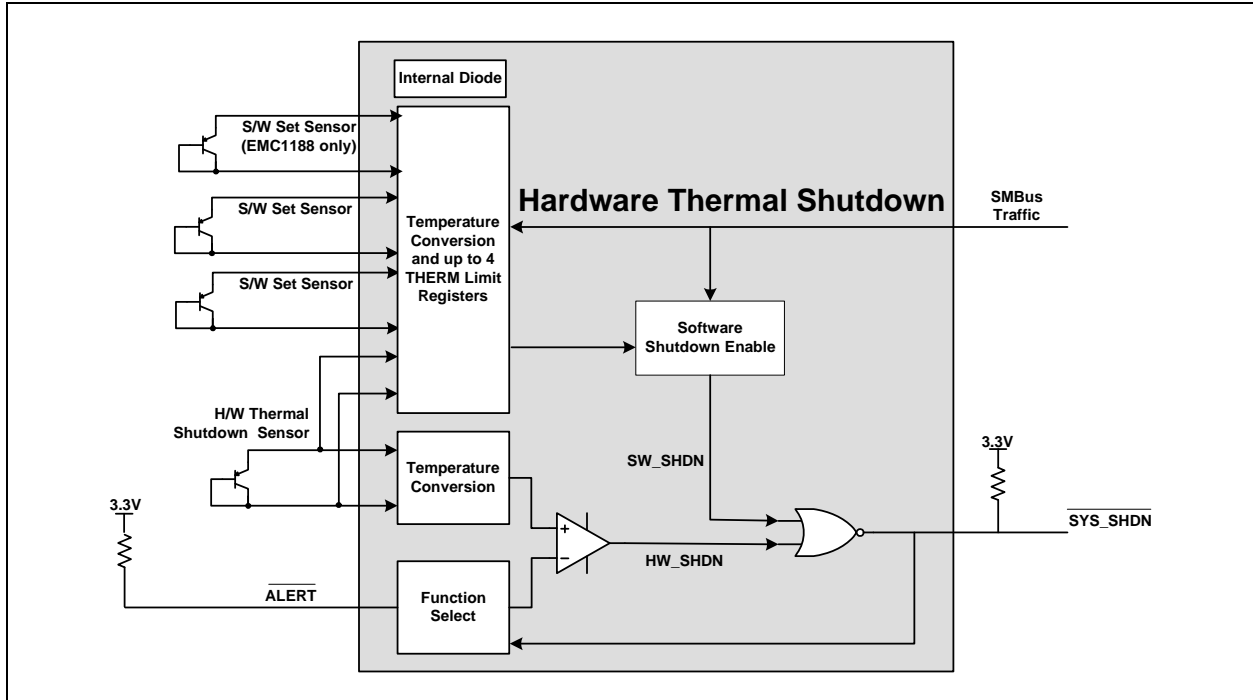

Figure 5.2 Block Diagram of Hardware Thermal Shutdown

## 5.4 Hardware Thermal Shutdown Limit

The Hardware Thermal Shutdown Limit temperature is determined by pull-up resistors on the SYS\_SHDN and ALERT pins shown in [Table 5.2](#).

Table 5.2 SYS\_SHDN Threshold Temperature

<u>SYS_SHD</u> PULL-UP <u>ALERT</u> PULL-UP	4.7K OHM ±10%	6.8K OHM ±10%	10K OHM ±10%	15K OHM ±10%	22K OHM ±10%	33K OHM ±10%
4.7K OHM ±10%	77°C	83°C	89°C	95°C	101°C	107°C
6.8K OHM ±10%	78°C	84°C	90°C	96°C	102°C	108°C
10K OHM ±10%	79°C	85°C	91°C	97°C	103°C	109°C
15K OHM ±10%	80°C	86°C	92°C	98°C	104°C	110°C
22K OHM ±10%	81°C	87°C	93°C	99°C	105°C	111°C
33K OHM ±10%	82°C	88°C	94°C	100°C	106°C	112°C

## 5.5 **ALERT** Output

The **ALERT** pin is an open drain output and requires a pull-up resistor to  $V_{DD}$  and has two modes of operation: interrupt mode and comparator mode. The mode of the **ALERT** output is selected via the **ALERT / COMP** bit in the Configuration Register (see [Section 6.4](#)).

### 5.5.1 **ALERT** Pin Interrupt Mode

When configured to operate in interrupt mode, the **ALERT** pin asserts low when an out of limit measurement ( $\geq$  high limit or  $<$  low limit) is detected on any diode or when a diode fault is detected, functioning as any standard **ALERT** in on the SMBus. The **ALERT** pin will remain asserted as long as an out-of-limit condition remains. Once the out-of-limit condition has been removed, the **ALERT** pin will remain asserted until the appropriate status bits are cleared.

The **ALERT** pin can be masked by setting the **MASK\_ALL** bit. Once the **ALERT** pin has been masked, it will be de-asserted and remain de-asserted until the **MASK\_ALL** bit is cleared by the user. Any interrupt conditions that occur while the **ALERT** pin is masked will update the Status Register normally. There are also individual channel masks (see [Section 6.12](#)).

The **ALERT** pin is used as an interrupt signal or as an SMBus Alert signal that allows an SMBus slave to communicate an error condition to the master. One or more **ALERT** outputs can be hard-wired together.

### 5.5.2 **ALERT** Pin Comparator Mode

When the **ALERT** pin is configured to operate in comparator mode, it will be asserted if any of the measured temperatures exceeds the respective high limit. The **ALERT** pin will remain asserted until all temperatures drop below the corresponding high limit minus the Therm Hysteresis value.

When the **ALERT** pin is asserted in comparator mode, the corresponding high limit status bits will be set. Reading these bits will not clear them until the **ALERT** pin is deasserted. Once the **ALERT** pin is deasserted, the status bits will be automatically cleared.

The **MASK\_ALL** bit will not block the **ALERT** pin in this mode; however, the individual channel masks (see [Section 6.12](#)) will prevent the respective channel from asserting the **ALERT** pin.

## 5.6 **ALERT** and **SYS\_SHDN** Pin Considerations

Because of the decode method used to determine the Hardware Thermal Shutdown Limit, it is important that the pull-up resistance on both the **ALERT** and **SYS\_SHDN** pins be within the tolerances shown in [Table 5.2](#). Additionally, the pull-up resistor on the **ALERT** and **SYS\_SHDN** pins must be connected to the same 3.3V supply that drives the **VDD** pin.

For 15ms after power up, the **ALERT** and **SYS\_SHDN** pins must not be pulled low or the Hardware Thermal Shutdown Limit will not be decoded properly. If the system requirements do not permit these conditions, the **ALERT** and **SYS\_SHDN** pins must be isolated from their respective busses during this time.

One method of isolating the **ALERT** pin is shown in [Figure 5.3](#).

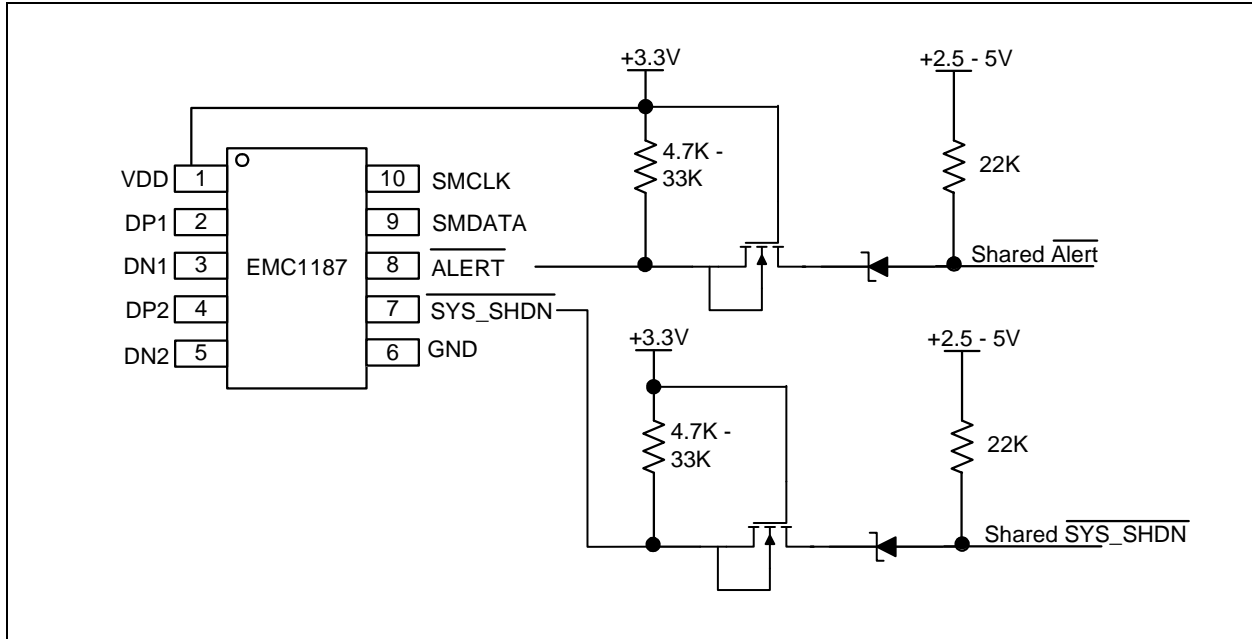
Figure 5.3 Isolating `ALERT` and `SYS_SHDN` Pin

## 5.7 Temperature Measurement

The EMC1187 can monitor the temperature of up to two externally connected diodes.

The device contains programmable High, Low, and Therm limits for all measured temperature channels. If the measured temperature goes below the Low limit or above the High limit, the `ALERT` pin can be asserted (based on user settings).

### 5.7.1 Beta Compensation

The EMC1187 is configured to monitor the temperature of basic diodes (e.g., 2N3904) or CPU thermal diodes. It automatically detects the type of external diode (CPU diode or diode connected transistor) and determines the optimal setting to reduce temperature errors introduced by beta variation. Compensating for this error is also known as implementing the transistor or BJT model for temperature measurement.

For discrete transistors configured with the collector and base shorted together, the beta is generally sufficiently high such that the percent change in beta variation is very small. For example, a 10% variation in beta for two forced emitter currents with a transistor whose ideal beta is 50 would contribute approximately 0.25°C error at 100°C. However for substrate transistors where the base-emitter junction is used for temperature measurement and the collector is tied to the substrate, the proportional beta variation will cause large error. For example, a 10% variation in beta for two forced emitter currents with a transistor whose ideal beta is 0.5 would contribute approximately 8.25°C error at 100°C.

### 5.7.2 Resistance Error Correction (REC)

Parasitic resistance in series with the external diodes will limit the accuracy obtainable from temperature measurement devices. The voltage developed across this resistance by the switching diode currents cause the temperature measurement to read higher than the true temperature. Contributors to series resistance are PCB trace resistance, on die (i.e. on the processor) metal resistance, bulk resistance in the base and emitter of the temperature transistor. Typically, the error

caused by series resistance is +0.7°C per ohm. The EMC1187 automatically corrects up to 100 ohms of series resistance.

### 5.7.3 Programmable External Diode Ideality Factor

The EMC1187 is designed for external diodes with an ideality factor of 1.008. Not all external diodes, processor or discrete, will have this exact value. This variation of the ideality factor introduces error in the temperature measurement which must be corrected for. This correction is typically done using programmable offset registers. Since an ideality factor mismatch introduces an error that is a function of temperature, this correction is only accurate within a small range of temperatures. To provide maximum flexibility to the user, the EMC1187 provides a 6-bit register for each external diode where the ideality factor of the diode used is programmed to eliminate errors across all temperatures.

**APPLICATION NOTE:** When monitoring a substrate transistor or CPU diode and beta compensation is enabled, the Ideality Factor should not be adjusted. Beta Compensation automatically corrects for most ideality errors.

## 5.8 Diode Faults

The EMC1187 detects an open on the DP and DN pins, and a short across the DP and DN pins. For each temperature measurement made, the device checks for a diode fault on the external diode channel(s). When a diode fault is detected, the  $\overline{\text{ALERT}}$  pin asserts (unless masked, see [Section 5.9](#)) and the temperature data reads 00h in the MSB and LSB registers (note: the low limit will not be checked). A diode fault is defined as one of the following: an open between DP and DN, a short from  $V_{DD}$  to DP, or a short from  $V_{DD}$  to DN.

If a short occurs across DP and DN or a short occurs from DP to GND, the low limit status bit is set and the  $\overline{\text{ALERT}}$  pin asserts (unless masked). This condition is indistinguishable from a temperature measurement of 0.000°C (-64°C in extended range) resulting in temperature data of 00h in the MSB and LSB registers.

If a short from DN to GND occurs (with a diode connected), temperature measurements will continue as normal with no alerts.

## 5.9 Consecutive Alerts

The EMC1187 contain multiple consecutive alert counters. One set of counters applies to the  $\overline{\text{ALERT}}$  pin and the second set of counters applies to the  $\overline{\text{SYS\_SHDN}}$  pin. Each temperature measurement channel has a separate consecutive alert counter for each of the  $\overline{\text{ALERT}}$  and  $\overline{\text{SYS\_SHDN}}$  pins. All counters are user programmable and determine the number of consecutive measurements that a temperature channel(s) must be out-of-limit or reporting a diode fault before the corresponding pin is asserted.

See [Section 6.13, "Consecutive ALERT Register 22h"](#) for more details on the consecutive alert function.

## 5.10 Digital Filter

To reduce the effect of noise and temperature spikes on the reported temperature, the External Diode channel uses a programmable digital filter. This filter can be configured as Level 1, Level 2, or Disabled (default) (see [Section 6.19](#)). The typical filter performance is shown in [Figure 5.4](#) and [Figure 5.5](#).

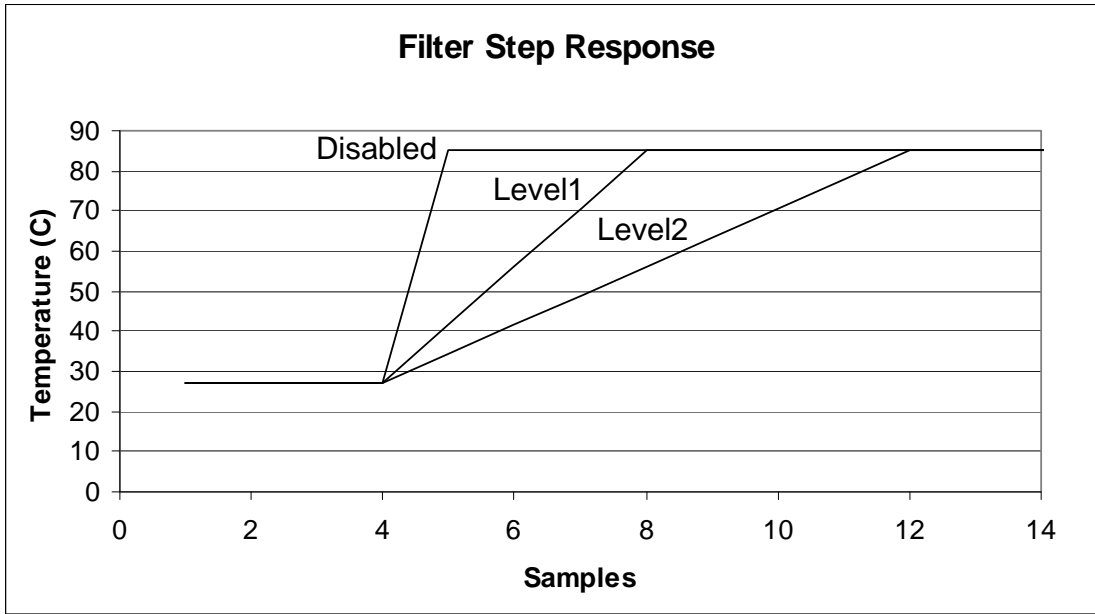

Figure 5.4 Temperature Filter Step Response

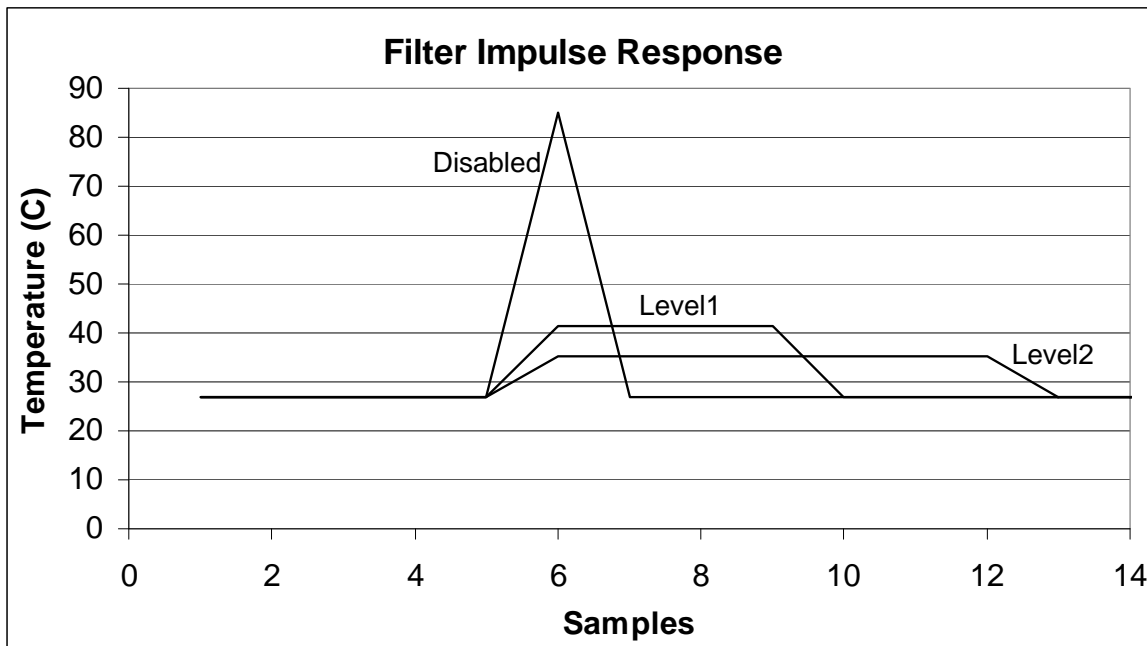

Figure 5.5 Temperature Filter Impulse Response

## 5.11 Temperature Measurement Results and Data

The temperature measurement results are stored in the internal and external temperature registers. These are then compared with the values stored in the high and low limit registers. Both external and internal temperature measurements are stored in 11-bit format with the eight (8) most significant bits stored in a high byte register and the three (3) least significant bits stored in the three (3) MSB positions of the low byte register. All other bits of the low byte register are set to zero.

The EMC1187 has two selectable temperature ranges. The default range is from 0°C to +127°C and the temperature is represented as binary number able to report a temperature from 0°C to +127.875°C in 0.125°C steps.

The extended range is an extended temperature range from -64°C to +191°C. The data format is a binary number offset by 64°C. The extended range is used to measure temperature diodes with a large known offset (such as AMD processor diodes) where the diode temperature plus the offset would be equivalent to a temperature higher than +127°C.

Table 5.3 shows the default and extended range formats.

**Table 5.3 Temperature Data Format**

TEMPERATURE (°C)	DEFAULT RANGE 0°C TO 127°C	EXTENDED RANGE -64°C TO 191°C
Diode Fault	000 0000 0000	000 0000 0000
-64	000 0000 0000	000 0000 0000
-1	000 0000 0000	001 1111 1000
0	000 0000 0000	010 0000 0000
0.125	000 0000 0001	010 0000 0001
1	000 0000 1000	010 0000 1000
64	010 0000 0000	100 0000 0000
65	010 0000 1000	100 0000 1000
127	011 1111 1000	101 1111 1000
127.875	011 1111 1111	101 1111 1111
128	011 1111 1111	110 0000 0000
190	011 1111 1111	111 1111 0000
191	011 1111 1111	111 1111 1000
>= 191.875	011 1111 1111	111 1111 1111



## Chapter 6 Register Description

The registers shown in [Table 6.1](#) are accessible through the SMBus. An entry of '-' indicates that the bit is not used and will always read '0'.

**Table 6.1 Register Set in Hexadecimal Order**

REGISTER ADDRESS	R/W	REGISTER NAME	FUNCTION	DEFAULT VALUE	PAGE
00h	R	Internal Diode Data High Byte	Stores the integer data for the Internal Diode	00h	Page 28
01h	R	External Diode Data High Byte	Stores the integer data for External Diode	00h	
02h	R	Status	Stores the status bits for the Internal Diode and External Diode	00h	Page 28
03h	R/W	Configuration	Controls the general operation of the device (mirrored at address 09h)		Page 29
04h	R/W	Conversion Rate	Controls the conversion rate for updating temperature data (mirrored at address 0Ah)	06h (4/sec)	Page 30
05h	R/W	Internal Diode High Limit	Stores the 8-bit high limit for the Internal Diode (mirrored at address 0Bh)	55h (85°C)	Page 31
06h	R/W	Internal Diode Low Limit	Stores the 8-bit low limit for the Internal Diode (mirrored at address 0Ch)	00h (0°C)	
07h	R/W	External Diode High Limit High Byte	Stores the integer portion of the high limit for External Diode (mirrored at register 0Dh)	55h (85°C)	
08h	R/W	External Diode Low Limit High Byte	Stores the integer portion of the low limit for External Diode (mirrored at register 0Eh)	00h (0°C)	
09h	R/W	Configuration	Controls the general operation of the device (mirrored at address 03h)		Page 29
0Ah	R/W	Conversion Rate	Controls the conversion rate for updating temperature data (mirrored at address 04h)	06h (4/sec)	Page 30

**Table 6.1 Register Set in Hexadecimal Order (continued)**

REGISTER ADDRESS	R/W	REGISTER NAME	FUNCTION	DEFAULT VALUE	PAGE
0Bh	R/W	Internal Diode High Limit	Stores the 8-bit high limit for the Internal Diode (mirrored at address 05h)	55h (85°C)	Page 31
0Ch	R/W	Internal Diode Low Limit	Stores the 8-bit low limit for the Internal Diode (mirrored at address 06h)	00h (0°C)	
0Dh	R/W	External Diode High Limit High Byte	Stores the integer portion of the high limit for External Diode (mirrored at register 07h)	55h (85°C)	
0Eh	R/W	External Diode Low Limit High Byte	Stores the integer portion of the low limit for External Diode (mirrored at register 08h)	00h (0°C)	
10h	R	External Diode Data Low Byte	Stores the fractional data for External Diode	00h	Page 28
11h	R/W	Scratchpad	Scratchpad register for software compatibility	00h	Page 32
12h	R/W	Scratchpad	Scratchpad register for software compatibility	00h	Page 32
13h	R/W	External Diode High Limit Low Byte	Stores the fractional portion of the high limit for External Diode	00h	Page 31
14h	R/W	External Diode Low Limit Low Byte	Stores the fractional portion of the low limit for External Diode	00h	
15h	R/W	External Diode 2 High Limit High Byte	Stores the integer portion of the high limit for External Diode 2	55h (85°C)	Page 31
16h	R/W	External Diode 2 Low Limit High Byte	Stores the integer portion of the low limit for External Diode 2	00h (0°C)	
17h	R/W	External Diode 2 High Limit Low Byte	Stores the fractional portion of the high limit External Diode 2	00h	Page 31
18h	R/W	External Diode 2 Low Limit Low Byte	Stores the fractional portion of the low limit for External Diode 2	00h	
19h	R/W	External Diode Therm Limit	Stores the 8-bit critical temperature limit for External Diode	55h (85°C)	Page 33
1Ah	R/W	External Diode 2 Therm Limit	Stores the 8-bit critical temperature limit for External Diode 2	55h (85°C)	Page 33
1Bh	R-C	External Diode Fault	Stores status bits indicating which external diode detected a diode fault	00h	Page 33
1Dh	R/W	SYS_SHDN Configuration	Controls which software channels, if any, are linked to the SYS_SHDN pin	00h	Page 33

**Table 6.1 Register Set in Hexadecimal Order (continued)**

REGISTER ADDRESS	R/W	REGISTER NAME	FUNCTION	DEFAULT VALUE	PAGE
1Eh	R	Hardware Thermal Shutdown Limit	When read, returns the selected Hardware Thermal Shutdown Limit	N/A	<a href="#">Page 34</a>
1Fh	R/W	Channel Mask Register	Controls the masking of individual channels	00h	<a href="#">Page 35</a>
20h	R/W	Internal Diode Therm Limit	Stores the 8-bit critical temperature limit for the Internal Diode	55h (85°C)	<a href="#">Page 33</a>
21h	R/W	Therm Hysteresis	Stores the 8-bit hysteresis value that applies to all Therm limits	0Ah (10°C)	
22h	R/W	Consecutive ALERT	Controls the number of out-of-limit conditions that must occur before an interrupt is asserted	70h	<a href="#">Page 35</a>
23h	R	External Diode 2 Data High Byte	Stores the integer data for External Diode 2	00h	<a href="#">Page 28</a>
24h	R	External Diode 2 Data Low Byte	Stores the fractional data for External Diode 2	00h	
26h	R/W	External Diode 2 Beta Configuration	Stores the Beta Compensation circuitry settings for External Diode 2	08h(EMC1 187) 07h	<a href="#">Page 38</a>
27h	R/W	External Diode Ideality Factor	Stores the ideality factor for External Diode	12h (1.008)	<a href="#">Page 38</a>
28h	R/W	External Diode 2 Ideality Factor	Stores the ideality factor for External Diode 2	12h (1.008)	<a href="#">Page 38</a>
29h	R	Internal Diode Data Low Byte	Stores the fractional data for the Internal Diode	00h	<a href="#">Page 28</a>
35h	R-C	High Limit Status	Status bits for the High Limits	00h	<a href="#">Page 40</a>
36h	R-C	Low Limit Status	Status bits for the Low Limits	00h	<a href="#">Page 40</a>
37h	R	Therm Limit Status	Status bits for the Therm Limits	00h	<a href="#">Page 41</a>
40h	R/W	Filter Control	Controls the digital filter setting for the External Diode channel	00h	<a href="#">Page 41</a>
FDh	R	Product ID (EMC1823)	Stores a fixed value that identifies the device	23h	<a href="#">Page 42</a>
FEh	R	Manufacturer ID	Stores a fixed value that represents SMSC	5Dh	<a href="#">Page 42</a>
FFh	R	Revision	Stores a fixed value that represents the revision number	07h	<a href="#">Page 42</a>

## 6.1 Data Read Interlock

When any temperature channel high byte register is read, the corresponding low byte is copied into an internal 'shadow' register. The user is free to read the low byte at any time and be guaranteed that it will correspond to the previously read high byte. Regardless if the low byte is read or not, reading from the same high byte register again will automatically refresh this stored low byte data.

## 6.2 Temperature Data Registers

Table 6.2 Temperature Data Registers

ADDR	R/W	REGISTER	B7	B6	B5	B4	B3	B2	B1	B0	DEFAULT
00h	R	Internal Diode High Byte	128	64	32	16	8	4	2	1	00h
29h	R	Internal Diode Low Byte	0.5	0.25	0.125	-	-	-	-	-	00h
01h	R	External Diode High Byte	128	64	32	16	8	4	2	1	00h
10h	R	External Diode Low Byte	0.5	0.25	0.125	-	-	-	-	-	00h
23h	R	External Diode 2 High Byte	128	64	32	16	8	4	2	1	00h
24h	R	External Diode 2 Low Byte	0.5	0.25	0.125	-	-	-	-	-	00h
2Ah	R	External Diode 3 High Byte	128	64	32	16	8	4	2	1	00h
2Bh	R	External Diode 3 Low Byte	0.5	0.25	0.125	-	-	-	-	-	00h

As shown in [Table 6.2](#), all temperatures are stored as an 11-bit value with the high byte representing the integer value and the low byte representing the fractional value left justified to occupy the MSBits.

## 6.3 Status Register 02h

Table 6.3 Status Register

ADDR	R/W	REGISTER	B7	B6	B5	B4	B3	B2	B1	B0	DEFAULT
02h	R	Status	BUSY	-	-	HIGH	LOW	FAULT	THERM	HWSD	00h

The Status Register reports general error conditions. To identify specific channels, refer to [Section 6.9](#), [Section 6.16](#), [Section 6.17](#), and [Section 6.18](#). The individual Status Register bits are cleared when the appropriate High Limit, Low Limit, or Therm Limit register has been read or cleared.

Bit 7 - **BUSY** - This bit indicates that the ADC is currently converting. This bit does not cause either the ALERT or THERM pin to be asserted.

Bit 4 - HIGH - This bit is set when any of the temperature channels exceeds its programmed high limit. See the High Limit Status Register for specific channel information ([Section 6.16](#)). When set, this bit will assert the  $\overline{\text{ALERT}}$  pin.

Bit 3 - LOW - This bit is set when any of the temperature channels drops below its programmed low limit. See the Low Limit Status Register for specific channel information ([Section 6.17](#)). When set, this bit will assert the  $\overline{\text{ALERT}}$  pin.

Bit 2 - FAULT - This bit is asserted when a diode fault is detected on any of the external diode channels. See the External Diode Fault Register for specific channel information ([Section 6.9](#)). When set, this bit will assert the  $\overline{\text{ALERT}}$  pin.

Bit 1 - THERM - This bit is set when the any of the temperature channels exceeds its programmed Therm Limit. See the Therm Limit Status Register for specific channel information ([Section 6.18](#)). When set, this bit will assert the  $\overline{\text{THERM}}$  pin.

Bit 0 - HWSD - This bit is set when the External Diode 1 Temperature exceeds the Hardware Thermal Shutdown Limit set by the pull-up resistors on the  $\overline{\text{ALERT}}$  and  $\text{SYS\_SHDN}$  pins. When set, this bit will assert the  $\text{SYS\_SHDN}$  pin.

## 6.4 Configuration Register 03h / 09h

Table 6.4 Configuration Register

ADDR	R/W	REGISTER	B7	B6	B5	B4	B3	B2	B1	B0	DEFAULT
03h	R/W	Configuration	MASK_ ALL	-	ALERT/ COMP	RECD	RECD2	RANGE	DAVG_ DIS	APDD	00h
09h											

The Configuration Register controls the basic operation of the device. This register is fully accessible at either address.

Bit 7 - MASK\_ALL - Masks the  $\overline{\text{ALERT}}$  pin from asserting.

- '0' - (default) - The  $\overline{\text{ALERT}}$  pin is not masked. If any of the appropriate status bits are set the  $\overline{\text{ALERT}}$  pin will be asserted.
- '1' - The  $\overline{\text{ALERT}}$  pin is masked. It will not be asserted for any interrupt condition unless it is configured in comparator mode. The Status Register will be updated normally.

Bit 5 - ALERT/COMP - Controls the operation of the  $\overline{\text{ALERT}}$  pin.

- '0' (default) - The  $\overline{\text{ALERT}}$  acts as an Alert pin and has interrupt behavior as described in [Section 5.5.1](#).
- '1' - The  $\overline{\text{ALERT}}$  acts as a THERM pin and has comparator behavior as described in [Section 5.5.2](#). In this mode the MASK\_ALL bit is ignored.

Bit 4 - RECD - Disables the Resistance Error Correction (REC) for External Diode.

- '0' (default) - REC is enabled for External Diode.
- '1' - REC is disabled for External Diode.

Bit 3 - RECD2 - Disables the Resistance Error Correction (REC) for External Diode 2 and External Diode 3.

- '0' (default) - REC is enabled for External Diode 2 and External Diode 3.
- '1' - REC is disabled for External Diode 2 and External Diode 3.

Bit 2 - RANGE - Configures the measurement range and data format of the temperature channels.

- '0' (default) - The temperature measurement range is 0°C to +127.875°C and the data format is binary.
- '1' -The temperature measurement range is -64°C to +191.875°C and the data format is offset binary (see [Table 5.3](#)).

Bit 1 - DAVG\_DIS - Disables the dynamic averaging feature on all temperature channels.

- '0' (default) - The dynamic averaging feature is enabled. All temperature channels will be converted with an averaging factor that is based on the conversion rate as shown in [Table 6.6](#).
- '1' - The dynamic averaging feature is disabled. All temperature channels will be converted with a maximum averaging factor of 1x (equivalent to 11-bit conversion). For higher conversion rates, this averaging factor will be reduced as shown in [Table 6.6](#).

## 6.5 Conversion Rate Register 04h / 0Ah

**Table 6.5 Conversion Rate Register**

ADDR	R/W	REGISTER	B7	B6	B5	B4	B3	B2	B1	B0	DEFAULT
04h	R/W	Conversion Rate	-	-	-	-	CONV[3:0]			06h (4/sec)	
0Ah											

The Conversion Rate Register controls how often the temperature measurement channels are updated and compared against the limits. This register is fully accessible at either address.

Bits 3-0 - CONV[3:0] - Determines the conversion rate as shown in [Table 6.6](#).

**Table 6.6 Conversion Rate**

CONV[3:0]					CONVERSIONS / SECOND
HEX	3	2	1	0	
0h	0	0	0	0	1
1h	0	0	0	1	1
2h	0	0	1	0	1
3h	0	0	1	1	
4h	0	1	0	0	1
5h	0	1	0	1	2
6h	0	1	1	0	4 (default)
7h	0	1	1	1	8
8h	1	0	0	0	16
9h	1	0	0	1	32

Table 6.6 Conversion Rate (continued)

CONV[3:0]					CONVERSIONS / SECOND
HEX	3	2	1	0	
Ah	1	0	1	0	64
Bh - Fh	All others				1

## 6.6 Limit Registers

Table 6.7 Temperature Limit Registers

ADDR.	R/W	REGISTER	B7	B6	B5	B4	B3	B2	B1	B0	DEFAULT
05h	R/W	Internal Diode High Limit	128	64	32	16	8	4	2	1	55h (85°C)
0Bh											
06h	R/W	Internal Diode Low Limit	128	64	32	16	8	4	2	1	00h (0°C)
0Ch											
07h	R/W	External Diode High Limit High Byte	128	64	32	16	8	4	2	1	55h (85°C)
0Dh											
13h	R/W	External Diode High Limit Low Byte	0.5	0.25	0.125	-	-	-	-	-	00h
08h	R/W	External Diode Low Limit High Byte	128	64	32	16	8	4	2	1	00h (0°C)
0Eh											
14h	R/W	External Diode Low Limit Low Byte	0.5	0.25	0.125	-	-	-	-	-	00h
15h	R/W	External Diode 2 High Limit High Byte	128	64	32	16	8	4	2	1	55h (85°C)
16h	R/W	External Diode 2 Low Limit High Byte	128	64	32	16	8	4	2	1	00h (0°C)
17h	R/W	External Diode 2 High Limit Low Byte	0.5	0.25	0.125	-	-	-	-	-	00h

**Table 6.7 Temperature Limit Registers (continued)**

ADDR.	R/W	REGISTER	B7	B6	B5	B4	B3	B2	B1	B0	DEFAULT
18h	R/W	External Diode 2 Low Limit Low Byte	0.5	0.25	0.125	-	-	-	-	-	00h
2Ch	R/W	External Diode 3 High Limit High Byte	128	64	32	16	8	4	2	1	55h (85°C)
2Dh	R/W	External Diode 3 Low Limit High Byte	128	64	32	16	8	4	2	1	00h (0°C)
2Eh	R/W	External Diode 3 High Limit Low Byte	0.5	0.25	0.125	-	-	-	-	-	00h
2Fh	R/W	External Diode 3 Low Limit Low Byte	0.5	0.25	0.125	-	-	-	-	-	00h

The device contains both high and low limits for all temperature channels. If the measured temperature exceeds the high limit, then the corresponding status bit is set and the ALERT pin is asserted. Likewise, if the measured temperature is less than or equal to the low limit, the corresponding status bit is set and the ALERT pin is asserted.

The data format for the limits must match the selected data format for the temperature so that if the extended temperature range is used, the limits must be programmed in the extended data format.

The limit registers with multiple addresses are fully accessible at either address.

## 6.7 Scratchpad Registers 11h and 12h

**Table 6.8 Scratchpad Register**

ADDR	R/W	REGISTER	B7	B6	B5	B4	B3	B2	B1	B0	DEFAULT
11h	R/W	Scratchpad	7	6	5	4	3	2	1	0	00h
12h	R/W	Scratchpad	7	6	5	4	3	2	1	0	00h

The Scratchpad Registers are Read / Write registers that are used for place holders to be software compatible with legacy programs. Reading from the registers will return what is written to them.



## 6.8 Therm Limit Registers

Table 6.9 Therm Limit Registers

ADDR.	R/W	REGISTER	B7	B6	B5	B4	B3	B2	B1	B0	DEFAULT
19h	R/W	External Diode Therm Limit	128	64	32	16	8	4	2	1	55h (85°C)
1Ah	R/W	External Diode 2 Therm Limit	128	64	32	16	8	4	2	1	55h (85°C)
20h	R/W	Internal Diode Therm Limit	128	64	32	16	8	4	2	1	55h (85°C)
21h	R/W	Therm Hysteresis	128	64	32	16	8	4	2	1	0Ah (10°C)

The Therm Limit Registers are used to determine whether a critical thermal event has occurred. If the measured temperature exceeds the Therm Limit, the  $\overline{\text{SYS\_SHDN}}$  pin will be asserted (if the corresponding measurement channel is linked to the  $\overline{\text{SYS\_SHDN}}$  pin - see [Section 6.10, "Software Thermal Shutdown Configuration Register 1Dh"](#)). The limit setting must match the chosen data format of the temperature reading registers.

## 6.9 External Diode Fault Register 1Bh

Table 6.10 External Diode Fault Register

ADDR.	R/W	REGISTER	B7	B6	B5	B4	B3	B2	B1	B0	DEFAULT
1Bh	R-C	External Diode Fault	-	-	-	-		E2FLT	E1FLT	-	00h

The External Diode Fault Register indicates which of the external diodes caused the FAULT bit in the Status Register to be set. This register is cleared when it is read.

Bit 2 - E2FLT - This bit is set if the External Diode 2 channel reported a diode fault.

Bit 1 - E1FLT - This bit is set if the External Diode 1 channel reported a diode fault.

## 6.10 Software Thermal Shutdown Configuration Register 1Dh

Table 6.11 Software Thermal Shutdown Configuration Register

ADDR.	R/W	REGISTER	B7	B6	B5	B4	B3	B2	B1	B0	DEFAULT
1Dh	R/W	Software Thermal Shutdown Configuration	-	-	-	-	-	E2SYS	EXT1SYS	INTSYS	00h

The Software Thermal Shutdown Configuration Register controls whether any of the software channels will assert the  $\overline{\text{SYS\_SHDN}}$  pin. If a channel is enabled, the temperature is compared against the corresponding Therm Limit. If the measured temperature exceeds the Therm Limit, the  $\overline{\text{SYS\_SHDN}}$  pin is asserted. This functionality is in addition to the Hardware Shutdown circuitry.

Bit 2 - E2SYS - Configures the External Diode 2 channel to assert the  $\overline{\text{SYS\_SHDN}}$  pin based on its Therm Limit.

- '0' (default) - The External Diode 2 channel is not linked to the  $\overline{\text{SYS\_SHDN}}$  pin. If the temperature exceeds its Therm Limit, the E2THERM status bit is set but the  $\overline{\text{SYS\_SHDN}}$  pin is not asserted.
- '1' - The External Diode 2 channel is linked to the  $\overline{\text{SYS\_SHDN}}$  pin. If the temperature exceeds its Therm Limit, the E2THERM status bit is set and the  $\overline{\text{SYS\_SHDN}}$  pin is asserted. It will remain asserted until the temperature drops below its Therm Limit minus the Therm Hysteresis.

Bit 1 - EXT1SYS - configures the External Diode 1 channel to assert the  $\overline{\text{SYS\_SHDN}}$  pin based on its Therm Limit.

- '0' (default) - The External Diode 1 channel is not linked to the  $\overline{\text{SYS\_SHDN}}$  pin. If the temperature exceeds the Therm Limit, the E1THERM status bit is set but the  $\overline{\text{SYS\_SHDN}}$  pin is not asserted.
- '1' - The External Diode 1 channel is linked to the  $\overline{\text{SYS\_SHDN}}$  pin. If the temperature exceeds its Therm Limit, the E1THERM status bit is set and the  $\overline{\text{SYS\_SHDN}}$  pin is asserted. It will remain asserted until the temperature drops below its Therm Limit minus the Therm Hysteresis.

Bit 0 - INTSYS - Configures the Internal Diode channel to assert the  $\overline{\text{SYS\_SHDN}}$  pin based on its Therm Limit.

- '0' (default) - The Internal Diode channel is not linked to the  $\overline{\text{SYS\_SHDN}}$  pin. If the temperature exceeds its Therm Limit, the ITHERM status bit is set but the  $\overline{\text{SYS\_SHDN}}$  pin is not asserted.
- '1' - The Internal Diode channel is linked to the  $\overline{\text{SYS\_SHDN}}$  pin. If the temperature exceeds its Therm Limit, the ITHERM status bit is set and the  $\overline{\text{SYS\_SHDN}}$  pin is asserted. It will remain asserted until the temperature drops below its Therm Limit minus the Therm Hysteresis.

## 6.11 Hardware Thermal Shutdown Limit Register 1Eh

Table 6.12 Hardware Thermal Shutdown Limit Register

ADDR.	R/W	REGISTER	B7	B6	B5	B4	B3	B2	B1	B0	DEFAULT
1Eh	R	Hardware Thermal Shutdown Limit	128	64	32	16	8	4	2	1	N/A

This read only register returns the Hardware Thermal Shutdown Limit selected by the value of the pull-up resistors on the  $\overline{\text{ALERT}}$  and  $\overline{\text{SYS\_SHDN}}$  pins. The data represents the hardware set temperature in °C using the active temperature setting set by the RANGE bit in the Configuration Register. See [Table 5.3, "Temperature Data Format"](#) for the data format.

When the External Diode 1 Temperature exceeds this limit, the  $\overline{\text{SYS\_SHDN}}$  pin is asserted and will remain asserted until the External Diode 1 Temperature drops below this limit minus 10°C.

## 6.12 Channel Mask Register 1Fh

Table 6.13 Channel Mask Register

ADDR.	R/W	REGISTER	B7	B6	B5	B4	B3	B2	B1	B0	DEFAULT
1Fh	R/W	Channel Mask	-	-	-	-	-	E2 MASK	E1 MASK	INT MASK	00h

The Channel Mask Register controls individual channel masking. When a channel is masked, the  $\overline{\text{ALERT}}$  pin will not be asserted when the masked channel reads a diode fault or out of limit error. The channel mask does not mask the  $\overline{\text{SYS\_SHDN}}$  pin.

Bit 2 - E2MASK - Masks the  $\overline{\text{ALERT}}$  pin from asserting when the External Diode 2 channel is out of limit or reports a diode fault.

- '0' (default) - The External Diode 2 channel will cause the  $\overline{\text{ALERT}}$  pin to be asserted if it is out of limit or reports a diode fault.
- '1' - The External Diode 2 channel will not cause the  $\overline{\text{ALERT}}$  pin to be asserted if it is out of limit or reports a diode fault.

Bit 1 - E1MASK - Masks the  $\overline{\text{ALERT}}$  pin from asserting when the External Diode1 channel is out of limit or reports a diode fault.

- '0' (default) - The External Diode1 channel will cause the  $\overline{\text{ALERT}}$  pin to be asserted if it is out of limit or reports a diode fault.
- '1' - The External Diode1 channel will not cause the  $\overline{\text{ALERT}}$  pin to be asserted if it is out of limit or reports a diode fault.

Bit 0 - INTMASK - Masks the  $\overline{\text{ALERT}}$  pin from asserting when the Internal Diode temperature is out of limit.

- '0' (default) - The Internal Diode channel will cause the  $\overline{\text{ALERT}}$  pin to be asserted if it is out of limit.
- '1' - The Internal Diode channel will not cause the  $\overline{\text{ALERT}}$  pin to be asserted if it is out of limit.

## 6.13 Consecutive ALERT Register 22h

Table 6.14 Consecutive ALERT Register

ADDR.	R/W	REGISTER	B7	B6	B5	B4	B3	B2	B1	B0	DEFAULT
22h	R/W	Consecutive ALERT	TIME OUT	CTHRM[2:0]			CALRT[2:0]			-	70h

The Consecutive ALERT Register determines how many times an out-of-limit error or diode fault must be detected in consecutive measurements before the  $\overline{\text{ALERT}}$  or  $\overline{\text{SYS\_SHDN}}$  pin is asserted. Additionally, the Consecutive ALERT Register controls the SMBus Timeout functionality.

An out-of-limit condition (i.e. HIGH, LOW, or FAULT) occurring on the same temperature channel in consecutive measurements will increment the consecutive alert counter. The counters will also be reset if no out-of-limit condition or diode fault condition occurs in a consecutive reading.

When the  $\overline{\text{ALERT}}$  pin is configured as an interrupt, when the consecutive alert counter reaches its programmed value, the following will occur: the STATUS bit(s) for that channel and the last error condition(s) (i.e. E1HIGH or E2LOW and/or E2FAULT) will be set to '1', the  $\overline{\text{ALERT}}$  pin will be asserted, the consecutive alert counter will be cleared, and measurements will continue.

When the  $\overline{\text{ALERT}}$  pin is configured as a comparator, the consecutive alert counter will ignore diode fault and low limit errors and only increment if the measured temperature exceeds the High Limit. Additionally, once the consecutive alert counter reaches the programmed limit, the  $\overline{\text{ALERT}}$  pin will be asserted, but the counter will not be reset. It will remain set until the temperature drops below the High Limit minus the Therm Hysteresis value.

For example, if the CALRT[2:0] bits are set for 4 consecutive alerts on an EMC1187 device, the high limits are set at 70°C, and none of the channels are masked, the  $\overline{\text{ALERT}}$  pin will be asserted after the following four measurements:

1. Internal Diode reads 71°C and external diodes read 69°C. Consecutive alert counter for INT is incremented to 1.
2. Both the Internal Diode and External Diode1 read 71°C and External Diode 2 reads 68°C. Consecutive alert counter for INT is incremented to 2 and for EXT is set to 1.
3. The External Diode1 reads 71°C and both the Internal Diode and External Diode 2 read 69°C. Consecutive alert counter for INT and EXT2 are cleared and EXT1 is incremented to 2.
4. The Internal Diode reads 71°C and external diodes read 71°C. Consecutive alert counter for INT is set to 1, EXT2 is set to 1, and EXT is incremented to 3.
5. The Internal Diode reads 71°C and both the external diode read 71°C. Consecutive alert counter for INT is incremented to 2, EXT2 is set to 2, and EXT is incremented to 4. The appropriate status bits are set for EXT and the  $\overline{\text{ALERT}}$  pin is asserted. EXT counter is reset to 0 and all other counters hold the last value until the next temperature measurement.

Bit 7 - TIMEOUT - Determines whether the SMBus Timeout function is enabled.

- '0' (default) - The SMBus Timeout feature is disabled. The SMCLK line can be held low indefinitely without the device resetting its SMBus protocol.
- '1' - The SMBus Timeout feature is enabled. If the SMCLK line is held low for more than  $t_{\text{TIMEOUT}}$ , the device will reset the SMBus protocol.

Bits 6-4 CTHRM[2:0] - Determines the number of consecutive measurements that must exceed the corresponding Therm Limit and Hardware Thermal Shutdown Limit before the  $\overline{\text{SYS\_SHDN}}$  pin is asserted. All temperature channels use this value to set the respective counters. The consecutive THERM counter is incremented whenever any of the measurements exceed the corresponding Therm Limit or if the External Diode 1 measurement exceeds the Hardware Thermal Shutdown Limit.

If the temperature drops below the Therm Limit or Hardware Thermal Shutdown Limit, the counter is reset. If the programmed number of consecutive measurements exceed the Therm Limit or Hardware Thermal Shutdown Limit, and the appropriate channel is linked to the  $\overline{\text{SYS\_SHDN}}$  pin, the  $\overline{\text{SYS\_SHDN}}$  pin will be asserted low.

Once the  $\overline{\text{SYS\_SHDN}}$  pin is asserted, the consecutive Therm counter will not reset until the corresponding temperature drops below the appropriate limit minus the corresponding hysteresis.

The bits are decoded as shown in [Table 6.15](#). The default setting is 4 consecutive out of limit conversions.

Bits 3-1 - CALRT[2:0] - Determine the number of consecutive measurements that must have an out of limit condition or diode fault before the  $\overline{\text{ALERT}}$  pin is asserted. temperature channels use this value to set the respective counters. The bits are decoded as shown in [Table 6.15](#). The default setting is 1 consecutive out of limit conversion.

Table 6.15 Consecutive Alert / Therm Settings

2	1	0	NUMBER OF CONSECUTIVE OUT OF LIMIT MEASUREMENTS
0	0	0	1 (default for CALRT[2:0])
0	0	1	2
0	1	1	3
1	1	1	4 (default for CTHRM[2:0])

## 6.14 Beta Configuration Registers 25h and 26h

Table 6.16 Beta Configuration Register

ADDR.	R/W	REGISTER	B7	B6	B5	B4	B3	B2	B1	B0	DEFAULT
26h	R	External Diode 2 Beta Configuration	-	-	-	-	ENABLE2	BETA2[2:0]			

This register is used to set the Beta Compensation factor that is used for External Diode 2s.  
External Diode 2.

- '0' - The Beta Compensation Factor auto-detection circuitry is disabled.
- '1' (default) - The Beta Compensation factor auto-detection circuitry is enabled. At the beginning of every conversion, the optimal Beta Compensation factor setting will be determined and applied. The BETA2X[2:0] bits will be automatically updated to indicate the current setting. This is the default for EMC1187

Bit 2-0 - BETA2[2:0] - These bits always reflect the current beta configuration settings. If auto-detection circuitry is enabled, these bits will be updated automatically and writing to these bits will have no effect. If the auto-detection circuitry is disabled, these bits will determine the beta configuration setting that is used for the respective channels. Care should be taken when setting the BETA2[2:0] bits when the auto-detection circuitry is disabled. If the Beta Compensation factor is set at a beta value that is higher than the transistor beta, the circuit may introduce measurement errors. When measuring a discrete thermal diode (such as 2N3904) or a CPU diode that functions like a discrete thermal diode (such as an AMD processor diode), the BETA2[2:0] bits should be set to '111b'.

Table 6.17 CPU Beta Values

HEX	ENABLE2	BETA2[2:0]			MINIMUM BETA
		2	1	0	
0h	0	0	0	0	0.11
1h	0	0	0	1	0.18

**Table 6.17 CPU Beta Values (continued)**

HEX	ENABLE2	BETA2[2:0]			MINIMUM BETA
		2	1	0	
2h	0	0	1	0	0.25
3h	0	0	1	1	0.33
4h	0	1	0	0	0.43
5h	0	1	0	1	1.00
6h	0	1	1	0	2.33
7h	0	1	1	1	Disabled
8h - Fh	1	X	X	X	Auto-detection

## 6.15 External Diode Ideality Factor Register 27h

**Table 6.18 Ideality Configuration Registers**

ADDR.	R/W	REGISTER	B7	B6	B5	B4	B3	B2	B1	B0	DEFAULT
27h	R/W	External Diode Ideality Factor	-	-	IDEALITY[5:0]					12h	
28h	R/W	External Diode 2 Ideality Factor	-	-	IDEALITY2[5:0]					12h	
31h	R/W	External Diode 3 Ideality Factor	-	-	IDEALITY3[5:0]					12h	

This register stores the ideality factors that are applied to the external diode. [Table 6.19](#) defines each setting and the corresponding ideality factor. Beta Compensation and Resistance Error Correction automatically correct for most diode ideality errors; therefore, it is not recommended that these settings be updated without consulting SMSC.

**Table 6.19 Ideality Factor Look-Up Table (Diode Model)**

SETTING	FACTOR	SETTING	FACTOR	SETTING	FACTOR
08h	0.9949	18h	1.0159	28h	1.0371
09h	0.9962	19h	1.0172	29h	1.0384
0Ah	0.9975	1Ah	1.0185	2Ah	1.0397

**Table 6.19 Ideality Factor Look-Up Table (Diode Model) (continued)**

SETTING	FACTOR	SETTING	FACTOR	SETTING	FACTOR
0Bh	0.9988	1Bh	1.0200	2Bh	1.0410
0Ch	1.0001	1Ch	1.0212	2Ch	1.0423
0Dh	1.0014	1Dh	1.0226	2Dh	1.0436
0Eh	1.0027	1Eh	1.0239	2Eh	1.0449
0Fh	1.0040	1Fh	1.0253	2Fh	1.0462
10h	1.0053	20h	1.0267	30h	1.0475
11h	1.0066	21h	1.0280	31h	1.0488
12h	1.0080	22h	1.0293	32h	1.0501
13h	1.0093	23h	1.0306	33h	1.0514
14h	1.0106	24h	1.0319	34h	1.0527
15h	1.0119	25h	1.0332	35h	1.0540
16h	1.0133	26h	1.0345	36h	1.0553
17h	1.0146	27h	1.0358	37h	1.0566

For CPU substrate transistors that require the BJT transistor model, the ideality factor behaves slightly differently than for discrete diode-connected transistors. Refer to [Table 6.20](#) when using a CPU substrate transistor.

**Table 6.20 Substrate Diode Ideality Factor Look-Up Table (BJT Model)**

SETTING	FACTOR	SETTING	FACTOR	SETTING	FACTOR
08h	0.9869	18h	1.0079	28h	1.0291
09h	0.9882	19h	1.0092	29h	1.0304
0Ah	0.9895	1Ah	1.0105	2Ah	1.0317
0Bh	0.9908	1Bh	1.0120	2Bh	1.0330
0Ch	0.9921	1Ch	1.0132	2Ch	1.0343
0Dh	0.9934	1Dh	1.0146	2Dh	1.0356
0Eh	0.9947	1Eh	1.0159	2Eh	1.0369
0Fh	0.9960	1Fh	1.0173	2Fh	1.0382
10h	0.9973	20h	1.0187	30h	1.0395
11h	0.9986	21h	1.0200	31h	1.0408
12h	1.0000	22h	1.0213	32h	1.0421
13h	1.0013	23h	1.0226	33h	1.0434

**Table 6.20 Substrate Diode Ideality Factor Look-Up Table (BJT Model) (continued)**

SETTING	FACTOR	SETTING	FACTOR	SETTING	FACTOR
14h	1.0026	24h	1.0239	34h	1.0447
15h	1.0039	25h	1.0252	35h	1.0460
16h	1.0053	26h	1.0265	36h	1.0473
17h	1.0066	27h	1.0278	37h	1.0486

**APPLICATION NOTE:** When measuring a 65nm Intel CPU, the Ideality Setting should be the default 12h. When measuring a 45nm Intel CPU, the Ideality Setting should be 15h.

## 6.16 High Limit Status Register 35h

**Table 6.21 High Limit Status Register**

ADDR.	R/W	REGISTER	B7	B6	B5	B4	B3	B2	B1	B0	DEFAULT
35h	R-C	High Limit Status	-	-	-	-	-	E2HIGH	EHIGH	IHIGH	00h

The High Limit Status Register contains the status bits that are set when a temperature channel high limit is exceeded. If any of these bits are set, the HIGH status bit in the Status Register is set. Reading from the High Limit Status Register will clear all bits if. Reading from the register will also clear the HIGH status bit in the Status Register.

The  $\overline{\text{ALERT}}$  pin will be set if the programmed number of consecutive alert counts have been met and any of these status bits are set.

The status bits will remain set until read unless the  $\overline{\text{ALERT}}$  pin is configured as a comparator output (see [Section 5.5.2](#)).

Bit 2 - E2HIGH - This bit is set when the External Diode 2 channel exceeds its programmed high limit.

Bit 1 - E1HIGH - This bit is set when the External Diode 1 channel exceeds its programmed high limit.

Bit 0 - IHIGH - This bit is set when the Internal Diode channel exceeds its programmed high limit.

## 6.17 Low Limit Status Register 36h

**Table 6.22 Low Limit Status Register**

ADDR.	R/W	REGISTER	B7	B6	B5	B4	B3	B2	B1	B0	DEFAULT
36h	R-C	Low Limit Status	-	-	-	-	-	E2LOW	ELOW	ILOW	00h

The Low Limit Status Register contains the status bits that are set when a temperature channel drops below the low limit. If any of these bits are set, then the LOW status bit in the Status Register is set. Reading from the Low Limit Status Register will clear all bits. Reading from the register will also clear the LOW status bit in the Status Register.



The  $\overline{\text{ALERT}}$  pin will be set if the programmed number of consecutive alert counts have been met and any of these status bits are set.

The status bits will remain set until read unless the  $\overline{\text{ALERT}}$  pin is configured as a comparator output (see [Section 5.5.2](#)).

Bit 2 - E2LOW - This bit is set when the External Diode 2 channel drops below its programmed low limit.

Bit 1 - E1LOW - This bit is set when the External Diode 1 channel drops below its programmed low limit.

Bit 0 - ILOW - This bit is set when the Internal Diode channel drops below its programmed low limit.

## 6.18 Therm Limit Status Register 37h

Table 6.23 Therm Limit Status Register

ADDR.	R/W	REGISTER	B7	B6	B5	B4	B3	B2	B1	B0	DEFAULT
37h	R-C	Therm Limit Status	-	-	-	-		E2 THERM	E1 THERM	ITHERM	00h

The Therm Limit Status Register contains the status bits that are set when a temperature channel Therm Limit is exceeded. If any of these bits are set, the THERM status bit in the Status Register is set. Reading from the Therm Limit Status Register will not clear the status bits. Once the temperature drops below the Therm Limit minus the Therm Hysteresis, the corresponding status bits will be automatically cleared. The THERM bit in the Status Register will be cleared when all individual channel THERM bits are cleared.

Bit 2 - E2THERM - This bit is set when the External Diode 2 channel exceeds its programmed Therm Limit. When set, this bit will assert the  $\overline{\text{THERM}}$  pin.

Bit 1 - E1THERM - This bit is set when the External Diode 1 channel exceeds its programmed Therm Limit. When set, this bit will assert the  $\overline{\text{THERM}}$  pin.

Bit 0- ITHERM - This bit is set when the Internal Diode channel exceeds its programmed Therm Limit. When set, this bit will assert the  $\overline{\text{THERM}}$  pin.

## 6.19 Filter Control Register 40h

Table 6.24 Filter Configuration Register

ADDR.	R/W	REGISTER	B7	B6	B5	B4	B3	B2	B1	B0	DEFAULT
40h	R/W	Filter Control	-	-	-	-	-	-	FILTER[1:0]		00h

The Filter Configuration Register controls the digital filter on the External Diode channel.

Bits 1-0 - FILTER[1:0] - Control the level of digital filtering that is applied to the External Diode temperature measurement as shown in [Table 6.25](#). See [Figure 5.4](#) and [Figure 5.5](#) for examples on the filter behavior.

Table 6.25 FILTER Decode

FILTER[1:0]		AVERAGING
1	0	
0	0	Disabled (default)
0	1	Level 1
1	0	Level 1
1	1	Level 2

## 6.20 Product ID Register

Table 6.26 Product ID Register

ADDR	R/W	REGISTER	B7	B6	B5	B4	B3	B2	B1	B0	DEFAULT
FDh	R	Product ID (EMC1187)	0	0	1	0	0	0	1	1	23h

The Product ID Register holds a unique value that identifies the device.

## 6.21 SMSC ID Register

Table 6.27 Manufacturer ID Register

ADDR.	R/W	REGISTER	B7	B6	B5	B4	B3	B2	B1	B0	DEFAULT
FEh	R	SMSC ID	0	1	0	1	1	1	0	1	5Dh

The Manufacturer ID register contains an 8-bit word that identifies the SMSC as the manufacturer of the EMC1187.

## 6.22 Revision Register

Table 6.28 Revision Register

ADDR.	R/W	REGISTER	B7	B6	B5	B4	B3	B2	B1	B0	DEFAULT
FFh	R	Revision	0	0	0	0	0	1	1	1	07h

The Revision register contains an 8-bit word that identifies the die revision.

## Chapter 7 Typical Operating Curves

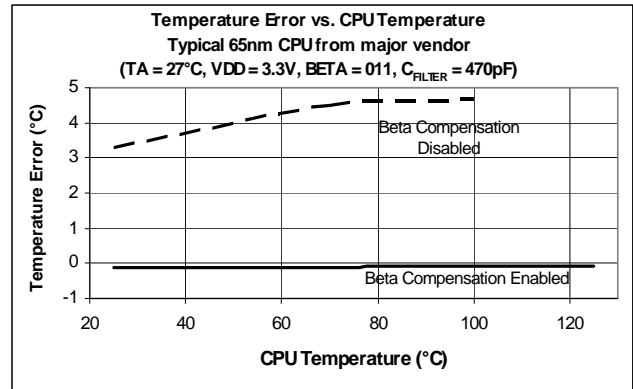
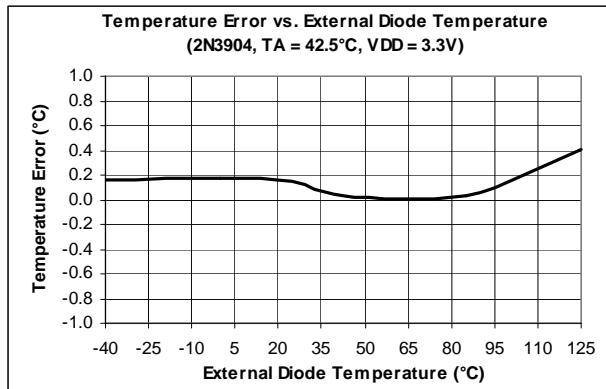
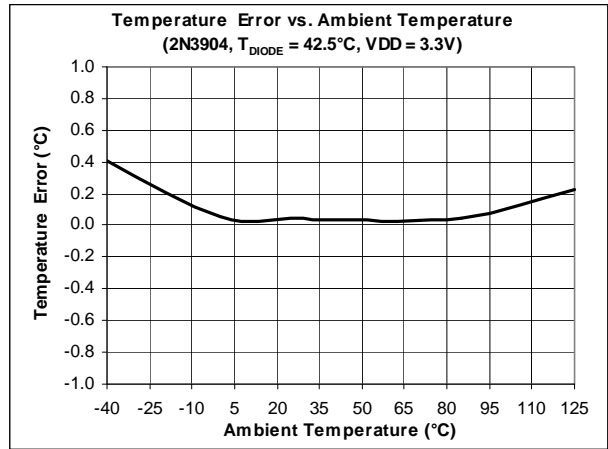
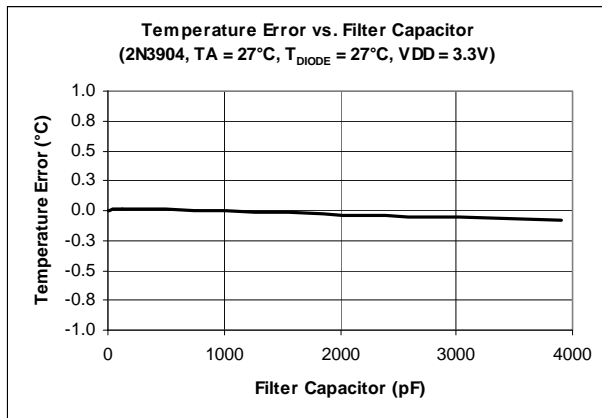

## Chapter 8 Package Information

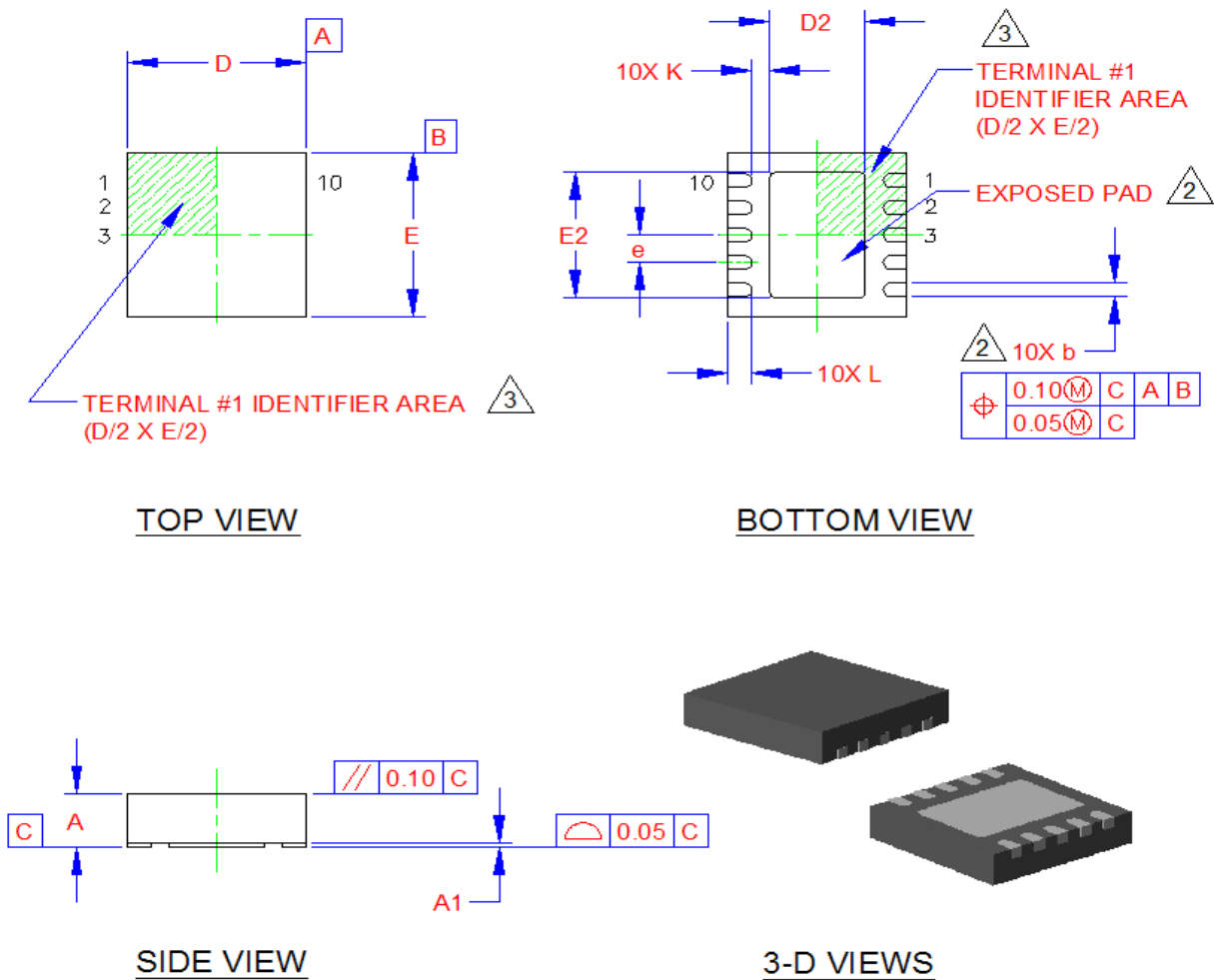

Figure 8.1 10-Pin DFN Package Drawing

## 8.1 Package Markings

COMMON DIMENSIONS					
SYMBOL	MIN	NOM	MAX	NOTE	REMARK
A	0.80	0.85	0.90	-	OVERALL PACKAGE HEIGHT
A1	0	0.02	0.05	-	STANDOFF
D/E	2.90	3.00	3.10	-	X/Y BODY SIZE
D2	1.50	1.60	1.70	2	X EXPOSED PAD SIZE
E2	2.20	2.30	2.40	2	Y EXPOSED PAD SIZE
L	0.35	0.40	0.45	-	TERMINAL LENGTH
b	0.18	0.25	0.30	2	TERMINAL WIDTH
K	0.25	0.30	-	-	TERMINAL TO PAD DISTANCE
e	0.50 BSC		-	-	TERMINAL PITCH

### NOTES:

1. ALL DIMENSIONS ARE IN MILLIMETERS.
2. UNILATERAL COPLANARITY ZONE APPLIES TO THE EXPOSED PAD, AS WELL AS THE TERMINALS. DIMENSIONS "b" APPLIES TO PLATED TERMINALS AND IT IS MEASURED BETWEEN 0.15 AND 0.30 mm FROM THE TERMINAL TIP.
3. DETAILS OF TERMINAL #1 IDENTIFIER ARE OPTIONAL BUT MUST BE LOCATED WITHIN THE AREA INDICATED.

Figure 8.2 10-Pin DFN Package Dimensions

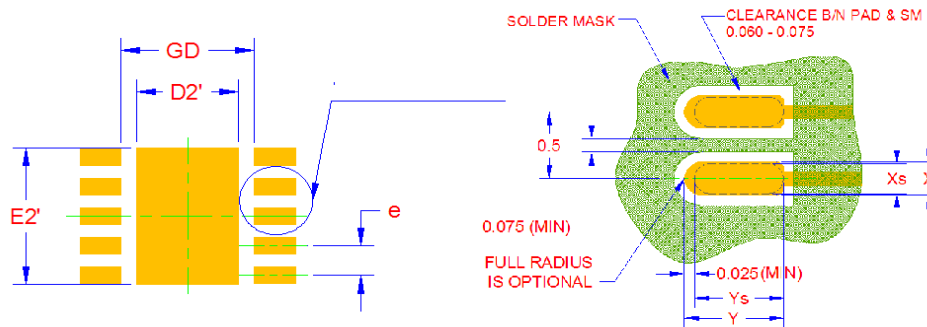

PCB LAND PATTERN

LAND PATTERN DIMENSIONS			
SYMBOL	MIN	NOM	MAX
GD	2.10	-	2.20
D2'	-	1.60	1.60
E2'	-	2.30	-
Pad: X	-	0.28	0.28
Pad: Y	-	0.69	0.69
e	0.50		

Figure 8.3 10 Pin DFN PCB Footprint

The EMC1187 devices will be marked as shown in [Figure 8.4](#).

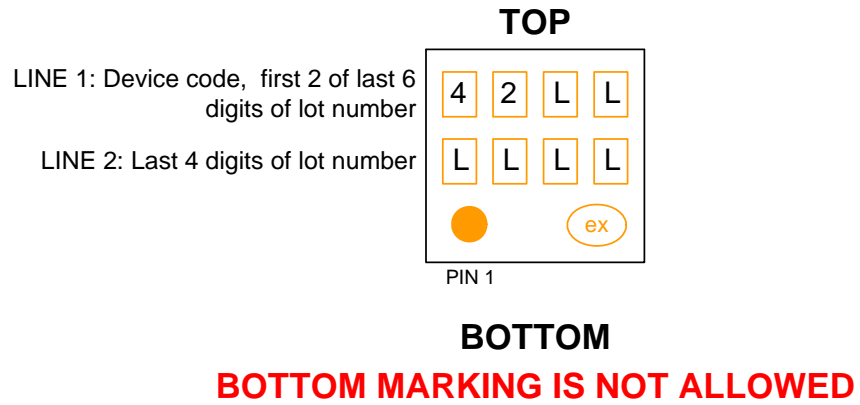

Figure 8.4 EMC1187-1 10-Pin DFN Package Markings

## Chapter 9 Datasheet Revision History

**Table 9.1 Customer Revision History**

<b>REVISION LEVEL &amp; DATE</b>	<b>SECTION/FIGURE/ENTRY</b>	<b>CORRECTION</b>
Rev. 1.0 (07-11-13)	Formal document release	

# Mouser Electronics

Authorized Distributor

Click to View Pricing, Inventory, Delivery & Lifecycle Information:

[Microchip:](#)

[EMC1187-1-AIA-TR](#) [EMC1187-1-AIA](#)



Компания «Океан Электроники» предлагает заключение долгосрочных отношений при поставках импортных электронных компонентов на взаимовыгодных условиях!

Наши преимущества:

- Поставка оригинальных импортных электронных компонентов напрямую с производств Америки, Европы и Азии, а так же с крупнейших складов мира;
- Широкая линейка поставок активных и пассивных импортных электронных компонентов (более 30 млн. наименований);
- Поставка сложных, дефицитных, либо снятых с производства позиций;
- Оперативные сроки поставки под заказ (от 5 рабочих дней);
- Экспресс доставка в любую точку России;
- Помощь Конструкторского Отдела и консультации квалифицированных инженеров;
- Техническая поддержка проекта, помощь в подборе аналогов, поставка прототипов;
- Поставка электронных компонентов под контролем ВП;
- Система менеджмента качества сертифицирована по Международному стандарту ISO 9001;
- При необходимости вся продукция военного и аэрокосмического назначения проходит испытания и сертификацию в лаборатории (по согласованию с заказчиком);
- Поставка специализированных компонентов военного и аэрокосмического уровня качества (Xilinx, Altera, Analog Devices, Intersil, Interpoint, Microsemi, Actel, Aeroflex, Peregrine, VPT, Syfer, Eurofarad, Texas Instruments, MS Kennedy, Miteq, Cobham, E2V, MA-COM, Hittite, Mini-Circuits, General Dynamics и др.);

Компания «Океан Электроники» является официальным дистрибьютором и эксклюзивным представителем в России одного из крупнейших производителей разъемов военного и аэрокосмического назначения «JONHON», а так же официальным дистрибьютором и эксклюзивным представителем в России производителя высокотехнологичных и надежных решений для передачи СВЧ сигналов «FORSTAR».



## JONHON

«JONHON» (основан в 1970 г.)

Разъемы специального, военного и аэрокосмического назначения:

(Применяются в военной, авиационной, аэрокосмической, морской, железнодорожной, горно- и нефтедобывающей отраслях промышленности)

«FORSTAR» (основан в 1998 г.)

ВЧ соединители, коаксиальные кабели, кабельные сборки и микроволновые компоненты:

(Применяются в телекоммуникациях гражданского и специального назначения, в средствах связи, РЛС, а так же военной, авиационной и аэрокосмической отраслях промышленности).



Телефон: 8 (812) 309-75-97 (многоканальный)

Факс: 8 (812) 320-03-32

Электронная почта: [ocean@oceanchips.ru](mailto:ocean@oceanchips.ru)

Web: <http://oceanchips.ru/>

Адрес: 198099, г. Санкт-Петербург, ул. Калинина, д. 2, корп. 4, лит. А