



# TAOGLAS®



# Datasheet

## 3-in-1 Sentinel

**Part No:**  
MA250.A.LBI.001

### **Description:**

Sentinel 3-in-1 Combination Adhesive Mount GNSS & 2\*4G MIMO antenna

### **Features:**

Ideal for IoT and Automotive Applications  
Small High-Performance Combination Antenna  
2 x Cellular 4G/3G/2G MIMO 1&2 Antennas  
1 x GPS-GLONASS-GALILEO-BeiDou L1 Active Antenna  
IP67 Waterproof  
High Efficiency  
Low Profile Housing – Only 14mm in Height  
Cables: 2m TGC-200 for Cellular and 2m RG-174 for GNSS  
Connector: SMA(M)  
Dimensions: 139\*76\*14mm  
RoHS & Reach Compliant

1. Introduction	3
2. Specifications	4
3. Antenna Characteristics	10
4. Radiation Patterns	15
5. Mechanical Drawing	17
6. Footprint	18
7. Packaging	19
<hr/>	
Changelog	20

Taoglas makes no warranties based on the accuracy or completeness of the contents of this document and reserves the right to make changes to specifications and product descriptions at any time without notice. Taoglas reserves all rights to this document and the information contained herein. Reproduction, use or disclosure to third parties without express permission is strictly prohibited.



# 1. Introduction

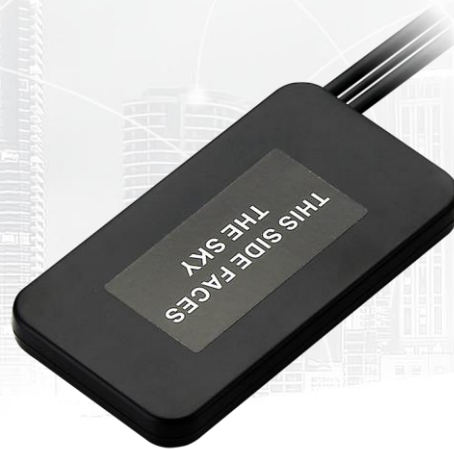

The MA250 Sentinel 3in1 Adhesive Mount 4G LTE MIMO and GPS/GLONASS/GALILEO/BeiDou L1/B1/E1 antenna is an omnidirectional, fully IP67 waterproof external M2M antenna for use in telematics, transportation and remote monitoring applications worldwide. It is designed to be mounted directly on glass or plastic in the interior of vehicles.

It is the smallest high performance solution in the market, 50% smaller than the previous generation, with higher efficiency and wider bandwidth to cover emerging LTE bands. Its performance is comparable with much larger permanent roof mount antennas and now offers a convenient and economical alternative in-cabin mounting solution.

Typical applications include:

- :: HD video over LTE
- :: Automotive vehicle tracking
- :: First Responder and Emergency Services
- :: Telematics

It is mounted via high quality, first tier automotive approved, 3M adhesive. In-house world leading dielectric ceramic antenna technology inside allows for smaller size antennas without loss in efficiency. It delivers powerful 2\*2 MIMO antenna technology for worldwide 4G LTE bands at 700MHz/ 800MHz/ 1700MHz/ 1800MHz /2300MHz /2600MHz, while allowing fallback to all common worldwide 3G and 2G frequency bands. The antenna has an output for GPS-GLONASS-GALILEO-BeiDou for next generation location accuracy.

4G wireless applications demand high speed data uplink and downlink. High efficiency and high gain MIMO antennas are necessary to achieve the required signal to noise ratio and throughput required to solve these challenges. Taoglas also takes care to have high isolation between the two MIMO antennas to prevent self-interference. Low loss cables are used to keep efficiency high over long cable lengths.

The IP67 waterproof housing measures just 139\*76\*14mm with 3M foam adhesive. The antenna can be mounted internally or externally on a vehicle. Both MIMO 1 and MIMO 2 coaxial cables are 2m low loss TGC-200 with SMA(M) connectors. The GPS-GLONASS-GALILEO-BeiDou cable is RG-174 with SMA(M) connector.

Customized cable and connector versions are also available. The antenna also comes in a 2in1 LTE/GNSS or a single LTE only variant. Contact your regional Taoglas customer support team for further information.

## 2. Specifications

GNSS Frequency Bands Covered							
<b>GPS/QZSS</b>	L1 1575.42MHz	L2 1227.6MHz	L5 1176.45MHz	L6 1278.75MHz			
	■	□	□	□			
<b>GLONASS</b>	L5R 1176.45MHz	L3PT 1201.5MHz	L2PT 1246MHz	L1CR 1575.42MHz	L1PT 1602MHz		
	□	□	□	■	■		
<b>Galileo</b>	E5a 1176.45MHz	E5b 1201.5MHz	E4 1215MHz	E3 1256MHz	E6 1278.75MHz	E2 1561MHz	L1 1575.42MHz
	□	□	□	□	□	■	■
<b>BeiDou</b>	B1 1561MHz	B2 1207.14MHz	B3 1268.52MHz				
	■	□	□				
<b>Compass</b>	E5B(B2)/ E6(B3) 1268.56MHz	E2(B1) 1561MHz					
	□	■					
<b>SBAS</b>	Omnistar 1542.5MHz	WAAS/EGN OS 1575.42MHz					
	□	■					

GNSS Electrical			
Frequency (MHz)	1561	1575.42	1602
VSWR (max.)	3:1	3:1	3:1
Passive Antenna Efficiency (%) (Without cable loss)	62.2	65.9	75.1
Passive Antenna Peak Gain at Zenith (dBi) (Without cable loss)	1.7	4.2	3
Average Gain	-2	-1.8	-1.3
Axial Ratio (dB)	9	12.5	20.6
Polarization	RHCP		
Impedance	50Ω		
Cable	2m RG-174		
Connector	SMA(M)ST		

<b>LNA and Filter Electrical Properties</b>			
<b>Frequency (MHz)</b>	<b>1561</b>	<b>1575.42</b>	<b>1602</b>
VSWR (max.)	2:1	2:1	2:1
Gain@1.8V (Typ.)	25.3	25.3	25.3
Gain@3.0V (Typ.)	28.6	28.6	28.6
Gain@5.5V (Typ.)	32.8	32.8	32.8
Noise@1.8V (Typ.)	2.3	2.3	2.3
Noise@3.0V (Typ.)	2.7	2.7	2.7
Noise@5.5V (Typ.)	3	3	3
Power consumption@1.8V (Typ.)	5mA		
Power consumption@3.0V (Typ.)	10mA		
Power consumption@5.5V (Typ.)	23mA		
<b>Total Specification (Through Antenna, SAW Filter and LNA)</b>			
<b>Frequency (MHz)</b>	<b>1561</b>	<b>1575.42</b>	<b>1602</b>
Gain@3V (dBi)	28.1	28.6	27.8
Output Impedance	50 Ω		
Return Loss	<-10dB		

4G/3G/2G MIMO 1 Antenna								
Frequency (MHz)		LTE700	GSM850	GSM900	DCS	PCS	UMTS1	LTE2600
		698~803	824~894	880~960	1710~1880	1850~1990	1920~2170	2490~2690
Efficiency (%)								
In free space	30cm	41.77	58.99	60.75	66.44	76.05	66.91	56.87
	1m	39.89	56.33	58.01	60.59	69.53	61.59	51.86
	2m	37.22	52.23	52.91	54.49	61.97	54.72	44.70
	3m	34.74	48.42	49.06	48.24	54.54	47.85	37.97
	5m	29.75	40.81	41.20	37.70	42.12	37.06	29.04
On 2mm ABS base	30cm	41.14	54.04	57.58	66.82	76.00	66.82	55.38
	1m	39.29	51.61	54.99	60.94	69.48	61.51	50.51
	2m	36.67	47.83	50.15	54.81	61.93	54.64	43.54
	3m	34.22	44.34	46.52	48.52	54.49	47.79	36.98
	5m	29.32	37.37	39.06	37.92	42.08	37.01	28.29
On glass base	30cm	43.33	55.50	58.33	63.40	63.83	55.87	56.49
	1m	41.38	53.00	55.71	57.82	58.35	51.42	51.52
	2m	38.62	49.13	50.81	52.03	52.01	45.69	44.42
	3m	36.04	45.54	47.12	46.04	45.77	39.95	37.74
	5m	30.91	38.38	39.57	36.00	35.35	30.95	28.86
Average Gain(dBi)								
In free space	30cm	-3.87	-2.29	-2.17	-1.81	-1.19	-1.81	-2.48
	1m	-4.07	-2.49	-2.37	-2.21	-1.58	-2.17	-2.88
	2m	-4.37	-2.82	-2.77	-2.66	-2.08	-2.68	-3.53
	3m	-4.67	-3.15	-3.10	-3.20	-2.63	-3.27	-4.23
	5m	-5.34	-3.89	-3.85	-4.26	-3.76	-4.37	-5.40
On 2mm ABS base	30cm	-3.89	-2.68	-2.41	-1.78	-1.19	-1.83	-2.60
	1m	-4.09	-2.88	-2.61	-2.18	-1.58	-2.18	-3.00
	2m	-4.39	-3.21	-3.01	-2.64	-2.08	-2.70	-3.64
	3m	-4.69	-3.54	-3.33	-3.17	-2.64	-3.28	-4.35
	5m	-5.36	-4.28	-4.09	-4.24	-3.76	-4.39	-5.51
On glass base	30cm	-3.65	-2.56	-2.34	-1.99	-1.95	-2.60	-2.50
	1m	-3.85	-2.76	-2.54	-2.39	-2.34	-2.95	-2.90
	2m	-4.15	-3.09	-2.94	-2.84	-2.84	-3.47	-3.54
	3m	-4.45	-3.42	-3.27	-3.38	-3.40	-4.05	-4.25
	5m	-5.12	-4.16	-4.03	-4.44	-4.52	-5.16	-5.41
Peak Gain(dBi)								
In free space	30cm	1.22	1.89	2.73	4.69	4.69	4.27	4.15
	1m	1.02	1.69	2.53	4.29	4.29	3.87	3.75
	2m	0.72	1.29	2.13	3.79	3.79	3.37	3.05
	3m	0.42	0.99	1.73	3.29	3.29	2.87	2.35
	5m	-0.28	0.19	1.03	2.19	2.19	1.67	1.15

On 2mm ABS base	30cm	0.76	1.57	1.79	3.68	3.68	3.22	3.24
	1m	0.56	1.37	1.59	3.28	3.28	2.86	2.84
	2m	0.26	0.97	1.19	2.78	2.78	2.36	2.14
	3m	-0.04	0.67	0.89	2.28	2.28	1.82	1.44
	5m	-0.74	-0.13	0.09	1.18	1.18	0.66	0.24
On glass base	30cm	1.86	1.94	2.06	3.10	2.90	2.90	3.66
	1m	1.66	1.74	1.86	2.70	2.50	2.50	3.26
	2m	1.36	1.44	1.46	2.30	2.00	2.00	2.56
	3m	1.06	1.14	1.06	1.70	1.40	1.40	1.86
	5m	0.46	0.34	0.36	0.70	0.30	0.30	0.75

### 4G/3G/2G MIMO 2 Antenna

Frequency (MHz)	LTE700	GSM850	GSM900	DCS	PCS	UMTS1	LTE2600	
	698~803	824~894	880~960	1710~1880	1850~1990	1920~2170	2490~2690	
Efficiency (%)								
In free space	30cm	46.24	33.45	35.37	54.05	57.08	51.87	67.48
	1m	44.16	31.95	33.78	49.29	52.17	47.71	61.55
	2m	41.21	29.61	30.81	44.42	46.50	42.38	53.09
	3m	38.46	27.44	28.56	39.27	40.93	37.07	45.10
	5m	33.09	23.13	24.00	30.73	31.59	28.70	34.48
On 2mm ABS base	30cm	50.50	40.14	42.93	53.67	56.84	53.32	66.89
	1m	48.23	38.33	41.00	48.95	51.96	49.05	61.01
	2m	45.01	35.53	37.39	44.10	46.31	43.57	52.61
	3m	42.01	32.93	34.66	39.00	40.76	38.10	44.68
	5m	36.10	27.75	29.12	30.51	31.46	29.51	34.17
On glass base	30cm	48.41	37.93	39.94	54.71	61.77	61.21	66.66
	1m	46.24	36.22	38.14	49.90	56.48	56.36	60.79
	2m	43.15	33.57	34.78	44.97	50.34	50.04	52.42
	3m	40.27	31.11	32.25	39.76	44.28	43.76	44.51
	5m	34.63	26.22	27.09	31.11	34.18	33.90	34.04
Average Gain(dBi)								
In free space	30cm	-3.87	-2.29	-2.17	-1.81	-1.19	-1.81	-2.48
	1m	-4.07	-2.49	-2.37	-2.21	-1.58	-2.17	-2.88
	2m	-4.37	-2.82	-2.77	-2.66	-2.08	-2.68	-3.53
	3m	-4.67	-3.15	-3.10	-3.20	-2.63	-3.27	-4.23
	5m	-5.34	-3.89	-3.85	-4.26	-3.76	-4.37	-5.40
On 2mm ABS base	30cm	-3.89	-2.68	-2.41	-1.78	-1.19	-1.83	-2.60
	1m	-4.09	-2.88	-2.61	-2.18	-1.58	-2.18	-3.00
	2m	-4.39	-3.21	-3.01	-2.64	-2.08	-2.70	-3.64
	3m	-4.69	-3.54	-3.33	-3.17	-2.64	-3.28	-4.35
	5m	-5.36	-4.28	-4.09	-4.24	-3.76	-4.39	-5.51

On glass base	30cm	-3.65	-2.56	-2.34	-1.99	-1.95	-2.60	-2.50
	1m	-3.85	-2.76	-2.54	-2.39	-2.34	-2.95	-2.90
	2m	-4.15	-3.09	-2.94	-2.84	-2.84	-3.47	-3.54
	3m	-4.45	-3.42	-3.27	-3.38	-3.40	-4.05	-4.25
	5m	-5.12	-4.16	-4.03	-4.44	-4.52	-5.16	-5.41
<b>Peak Gain(dBi)</b>								
In free space	30cm	1.22	1.89	2.73	4.69	4.69	4.27	4.15
	1m	1.02	1.69	2.53	4.29	4.29	3.87	3.75
	2m	0.72	1.29	2.13	3.79	3.79	3.37	3.05
	3m	0.42	0.99	1.73	3.29	3.29	2.87	2.35
	5m	-0.28	0.19	1.03	2.19	2.19	1.67	1.15
On 2mm ABS base	30cm	0.76	1.57	1.79	3.68	3.68	3.22	3.24
	1m	0.56	1.37	1.59	3.28	3.28	2.86	2.84
	2m	0.26	0.97	1.19	2.78	2.78	2.36	2.14
	3m	-0.04	0.67	0.89	2.28	2.28	1.82	1.44
	5m	-0.74	-0.13	0.09	1.18	1.18	0.66	0.24
On glass base	30cm	1.86	1.94	2.06	3.10	2.90	2.90	3.66
	1m	1.66	1.74	1.86	2.70	2.50	2.50	3.26
	2m	1.36	1.44	1.46	2.30	2.00	2.00	2.56
	3m	1.06	1.14	1.06	1.70	1.40	1.40	1.86
	5m	0.46	0.34	0.36	0.70	0.30	0.30	0.75



5G/4G Bands			
Band Number	5G NR / FR1 / LTE / LTE-Advanced / WCDMA / HSPA / HSPA+ / TD-SCDMA		
	Uplink	Downlink	Covered
1	UL: 1920 to 1980	DL: 2110 to 2170	✓
2	UL: 1850 to 1910	DL: 1930 to 1990	✓
3	UL: 1710 to 1785	DL: 1805 to 1880	✓
4	UL: 1710 to 1755	DL: 2110 to 2155	✓
5	UL: 824 to 849	DL: 869 to 894	✓
7	UL: 2500 to 2570	DL: 2620 to 2690	✓
8	UL: 880 to 915	DL: 925 to 960	✓
9	UL: 1749.9 to 1784.9	DL: 1844.9 to 1879.9	✓
11	UL: 1427.9 to 1447.9	DL: 1475.9 to 1495.9	✗
12	UL: 699 to 716	DL: 729 to 746	✓
13	UL: 777 to 787	DL: 746 to 756	✓
14	UL: 788 to 798	DL: 758 to 768	✓
17	UL: 704 to 716	DL: 734 to 746	✓
18	UL: 815 to 830	DL: 860 to 875	✓
19	UL: 830 to 845	DL: 875 to 890	✓
20	UL: 832 to 862	DL: 791 to 821	✓
21	UL: 1447.9 to 1462.9	DL: 1495.9 to 1510.9	✓
22	UL: 3410 to 3490	DL: 3510 to 3590	✗
23	UL: 2000 to 2020	DL: 2180 to 2200	✓
24	UL: 1625.5 to 1660.5	DL: 1525 to 1559	✓
25	UL: 1850 to 1915	DL: 1930 to 1995	✓
26	UL: 814 to 849	DL: 859 to 894	✓
27	UL: 807 to 824	DL: 852 to 869	✓
28	UL: 703 to 748	DL: 758 to 803	✓
29	UL: -	DL: 717 to 728	✓
30	UL: 2305 to 2315	DL: 2350 to 2360	✓
31	UL: 452.5 to 457.5	DL: 462.5 to 467.5	✗
32	UL: -	DL: 1452 – 1496	✗
35		1850 to 1910	✓
38		2570 to 2620	✓
39		1880 to 1920	✓
40		2300 to 2400	✓
41		2496 to 2690	✓
42		3400 to 3600	✗
43		3600 to 3800	✗
48		3550 to 3700	✗
66	UL: 1710-1780	DL: 2110-2200	✗
71		617 to 698	✗
74/75/76		1427 to 1518	✗
77		3300 to 4200	✗
78		3300 to 3800	✗
79		4400 to 5000	✗

<b>Mechanical</b>	
Dimension	139.27*76.27*14mm
Casing	ABS
Cable	GNSS: 2m RG-174 Cellular: 2m TGC-200
Connector	SMA(M)ST
Weight	280g
Adhesive	3M 1600TB-10
Ingress Protection	IP67
Temperature Range	-40°C to 85°C
Humidity	Non-condensing 65°C 95% RH

### 3. Antenna Characteristics

#### 3.1 Return Loss – GNSS

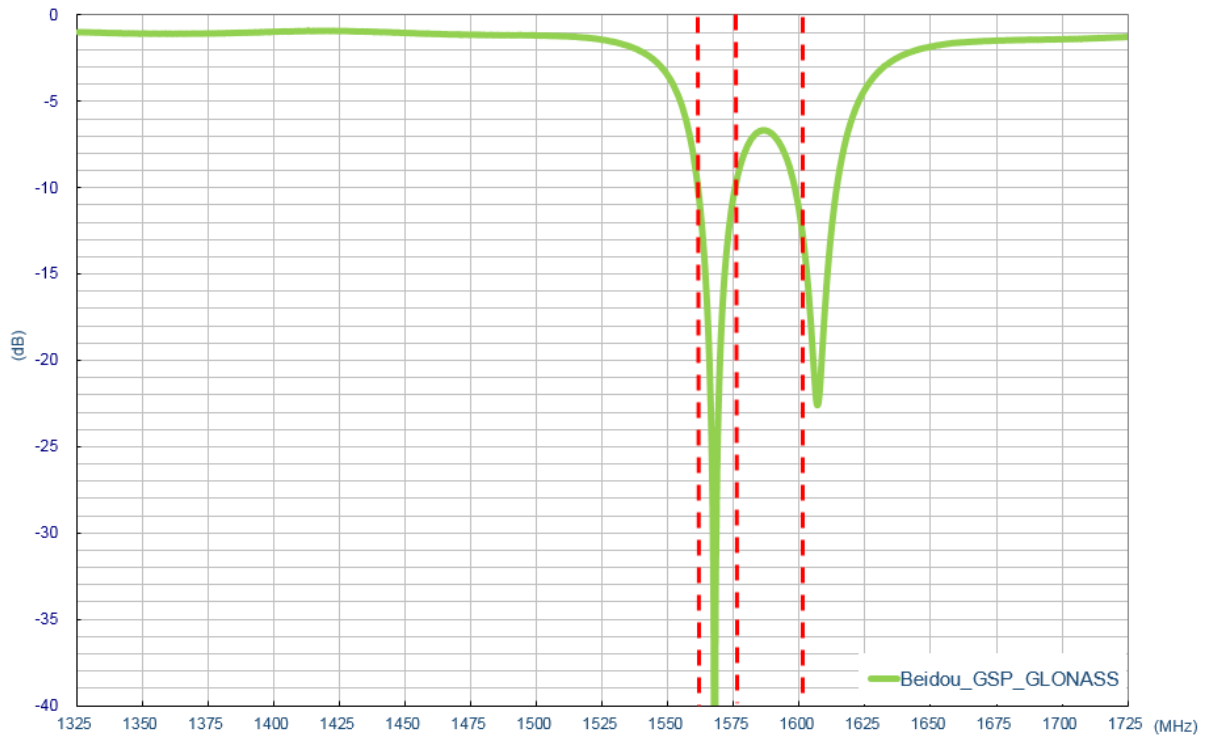

#### 3.2 Return Loss – 4G MIMO 1

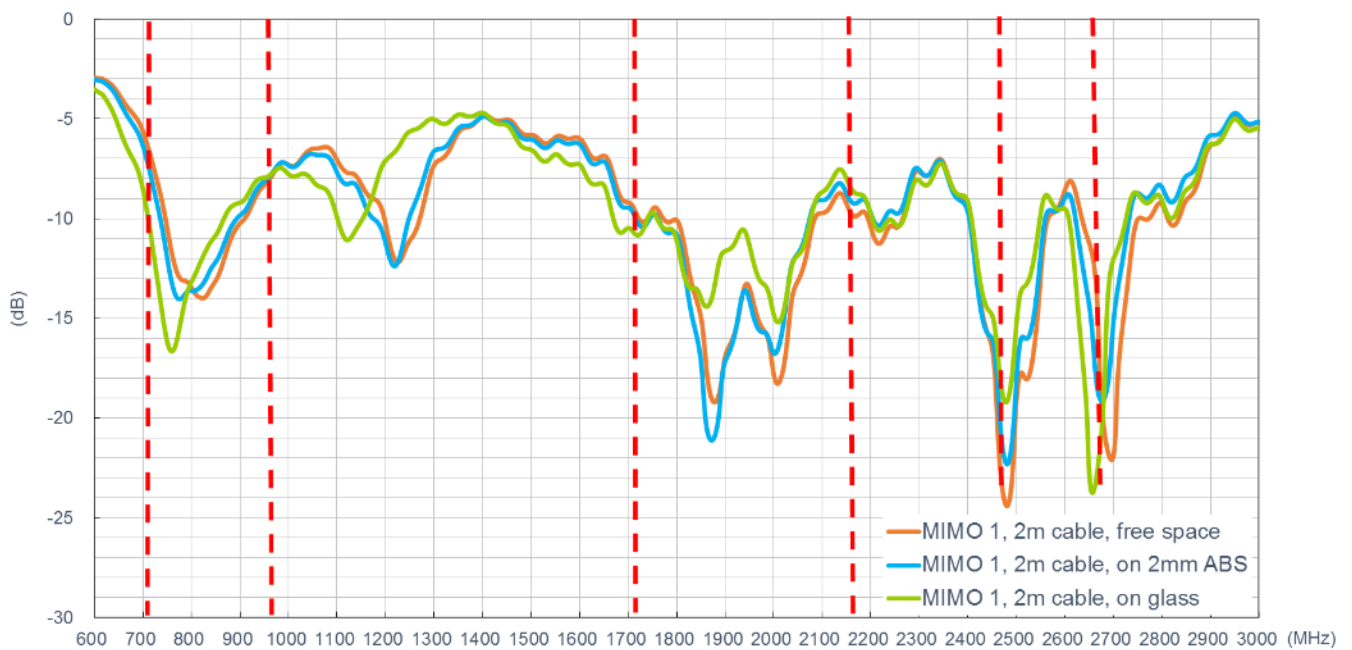

### 3.3 Return Loss – 4G MIMO 2

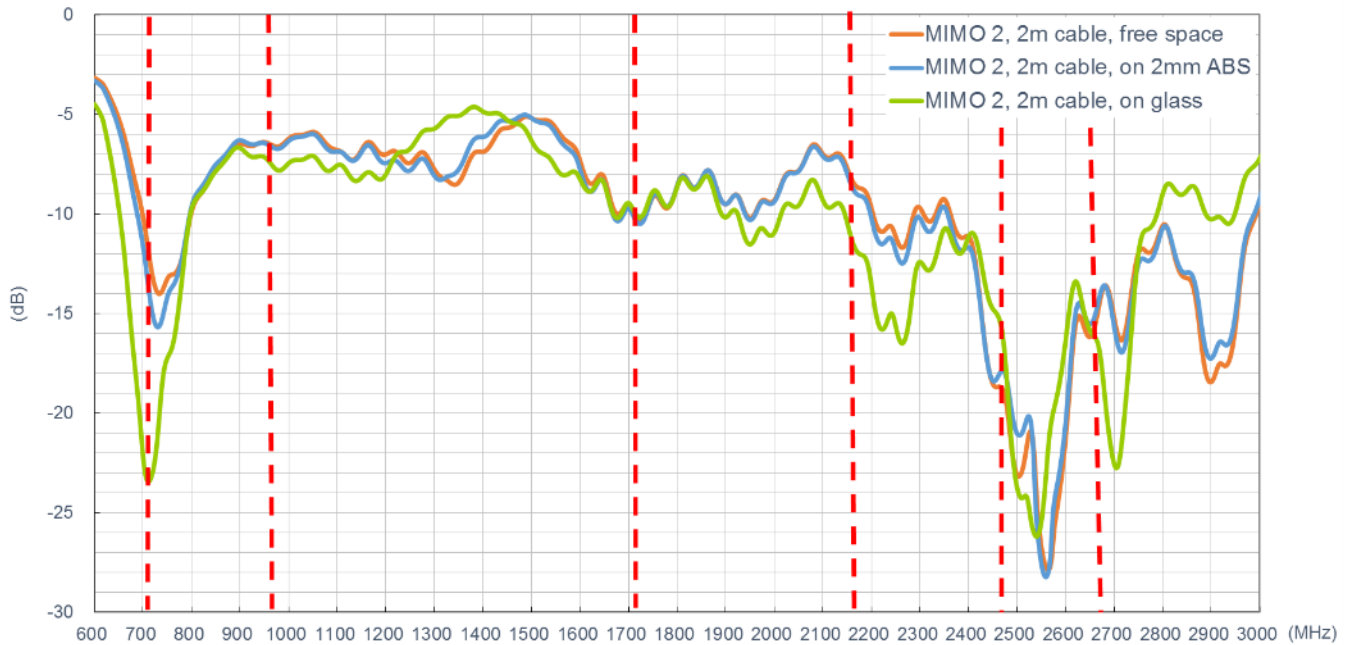

### 3.4 Isolation

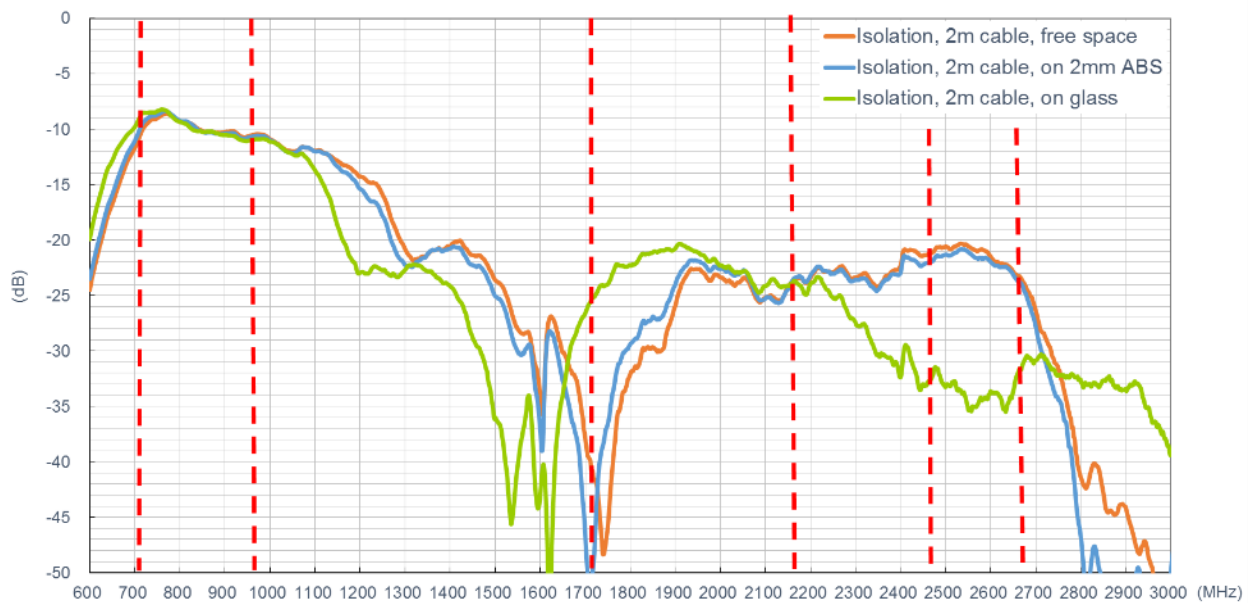

### 3.5 Efficiency – GNSS

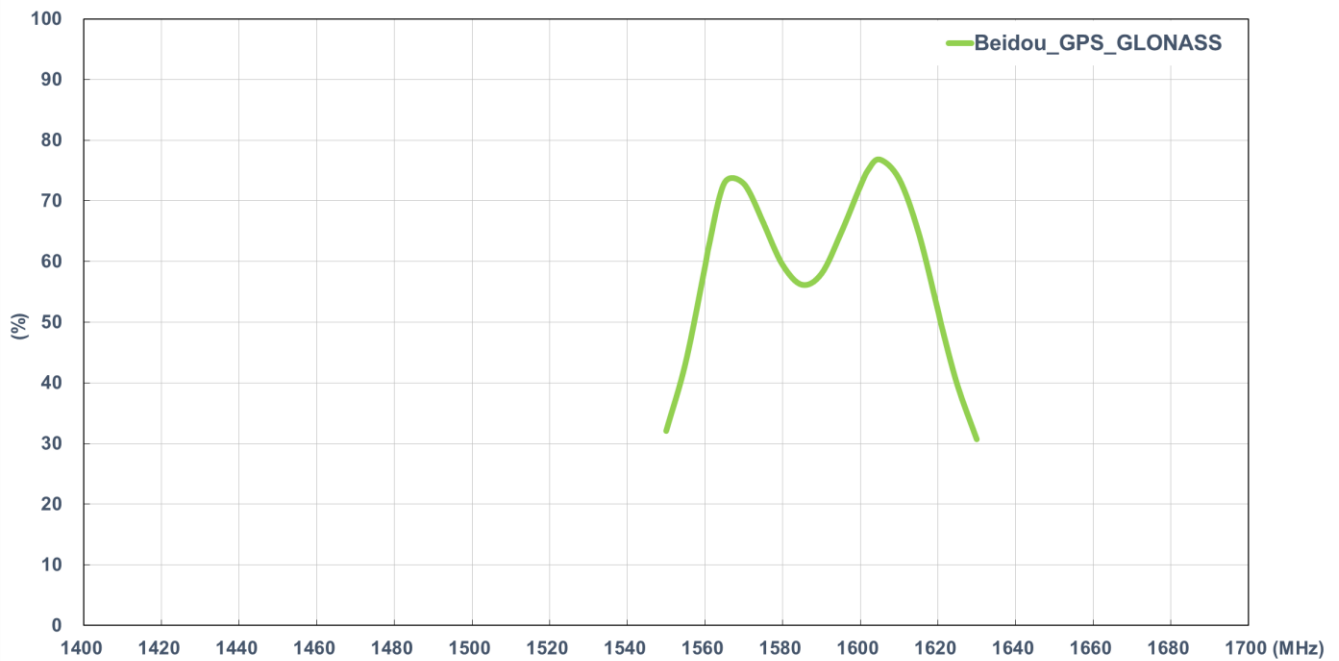

### 3.6 Efficiency – 4G MIMO 1

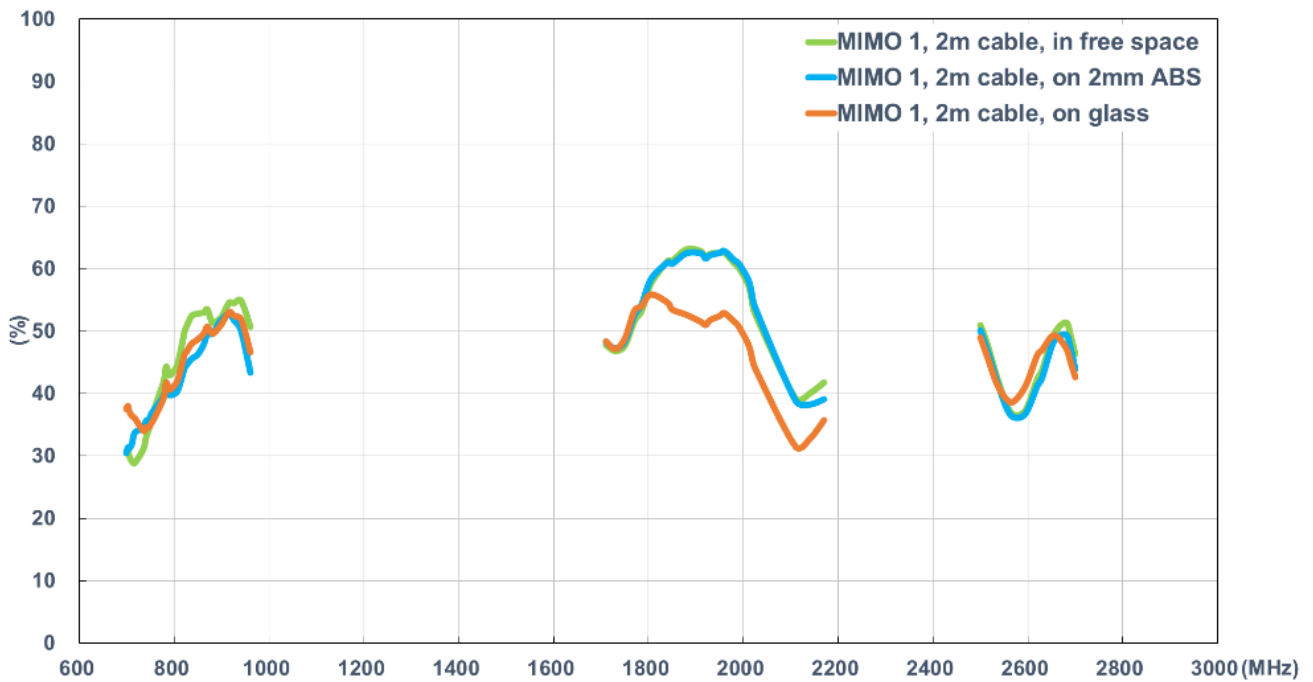

### 3.7 Efficiency – 4G MIMO 2

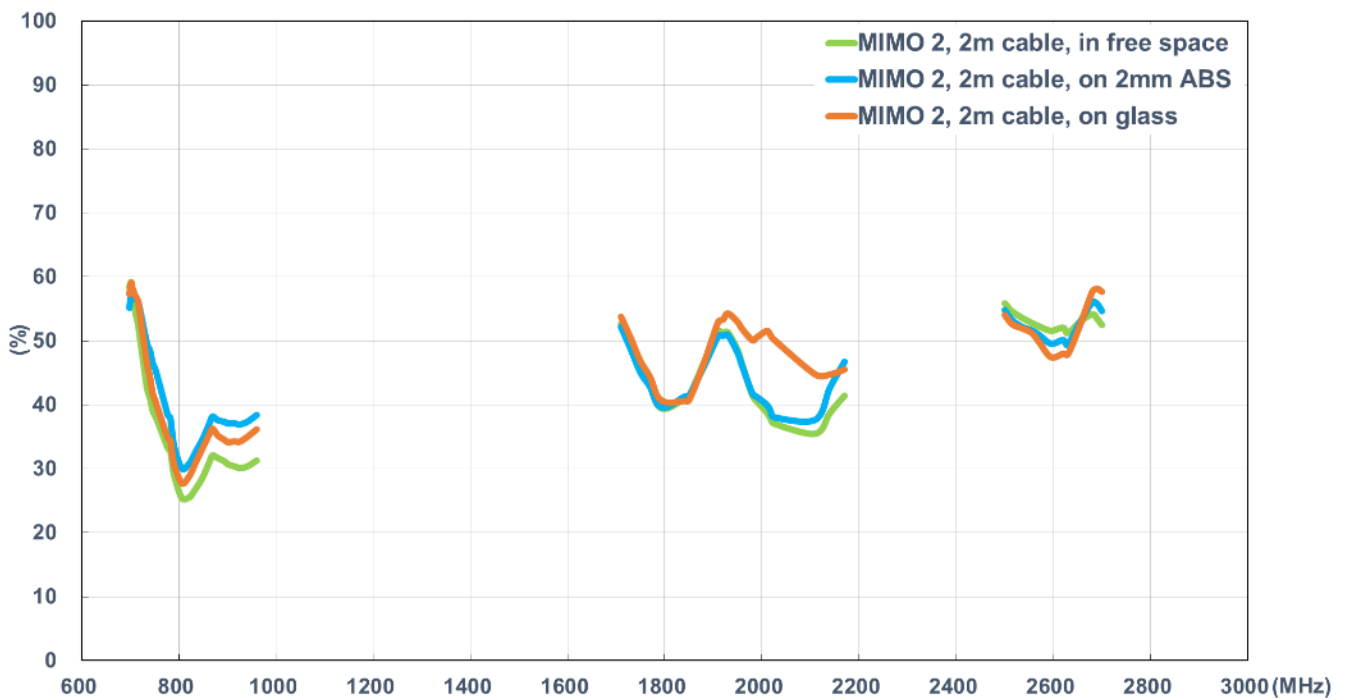

### 3.8 Average Gain - GNSS

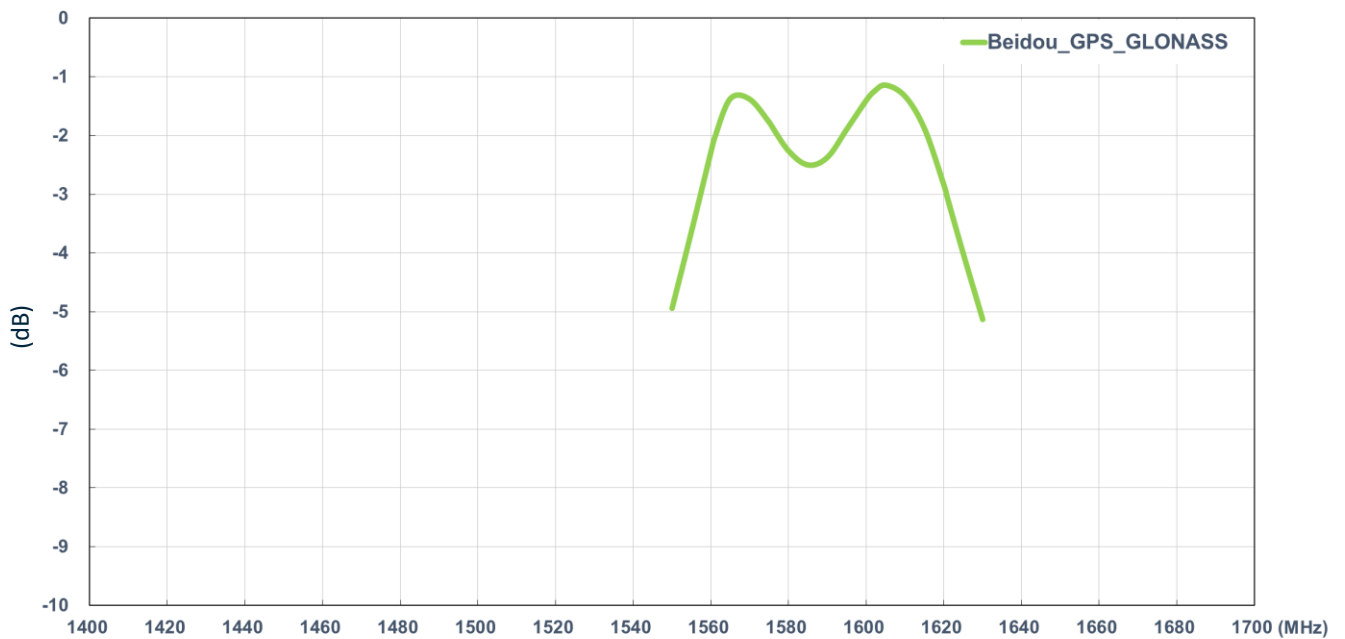

### 3.9 Average Gain – 4G MIMO 1

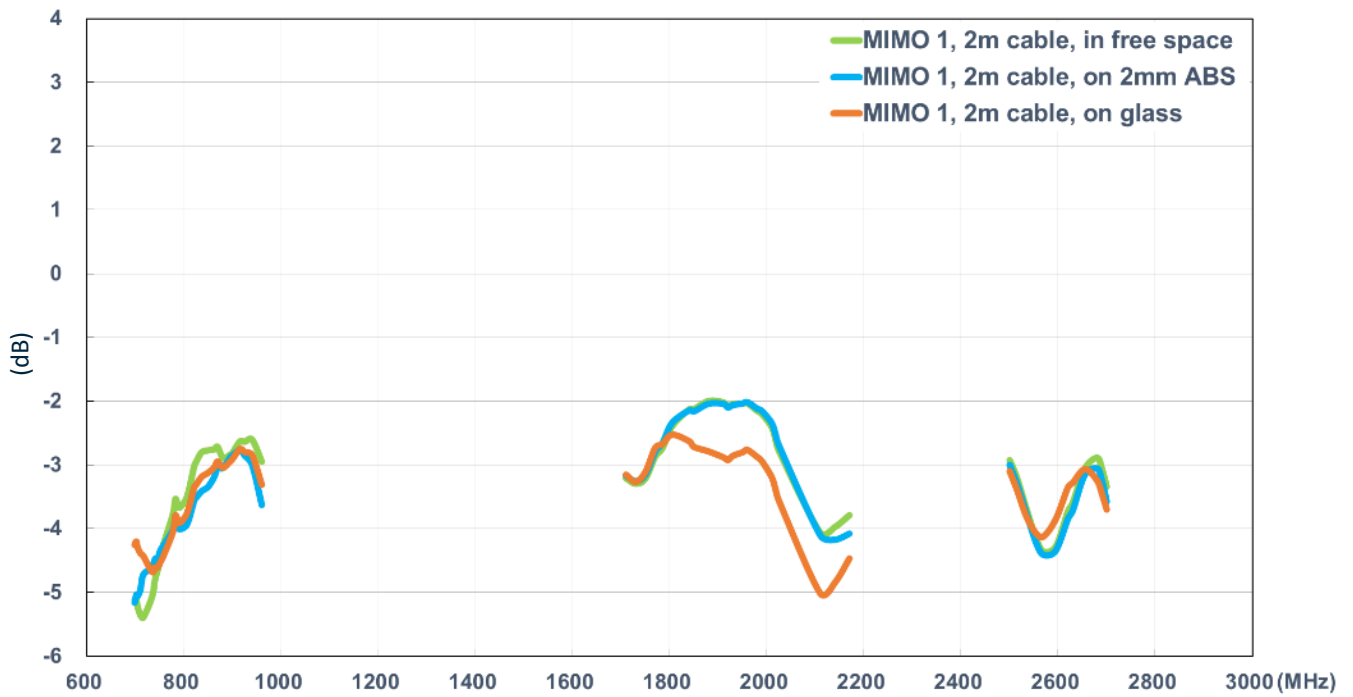

### 3.10 Average Gain – 4G MIMO 2

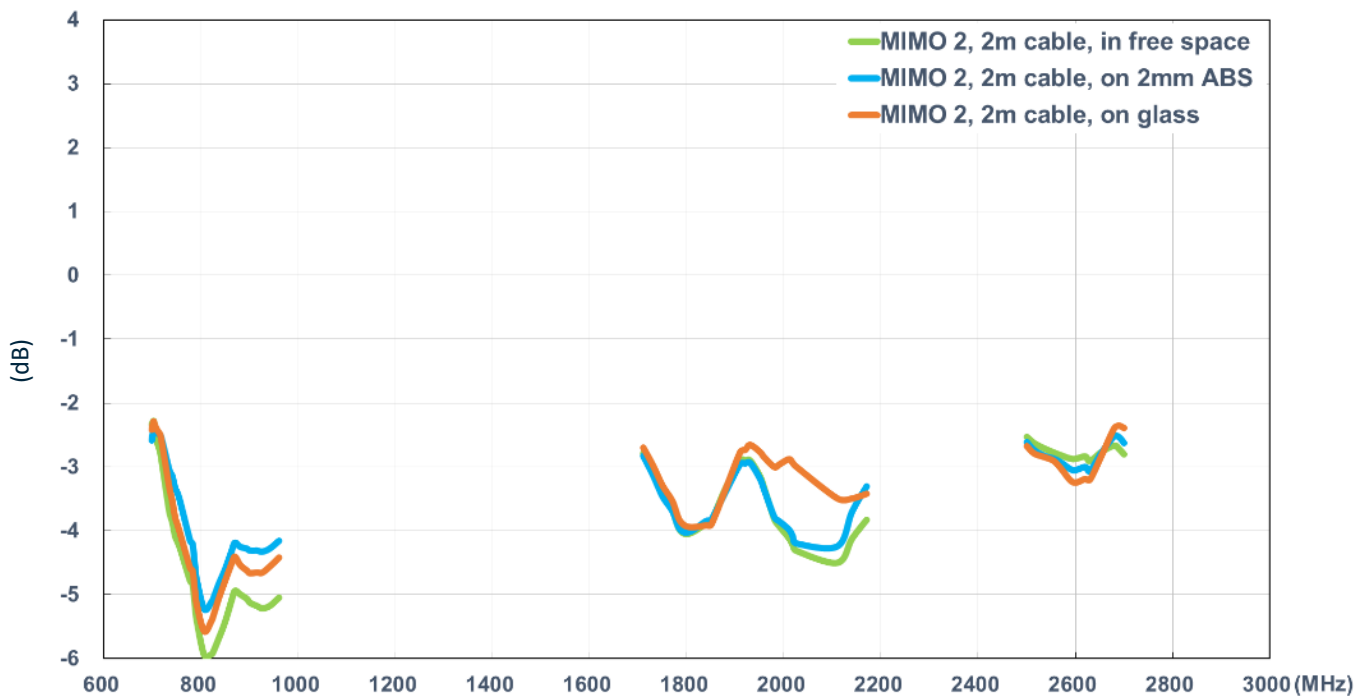

### 3.11 Peak Gain – GNSS

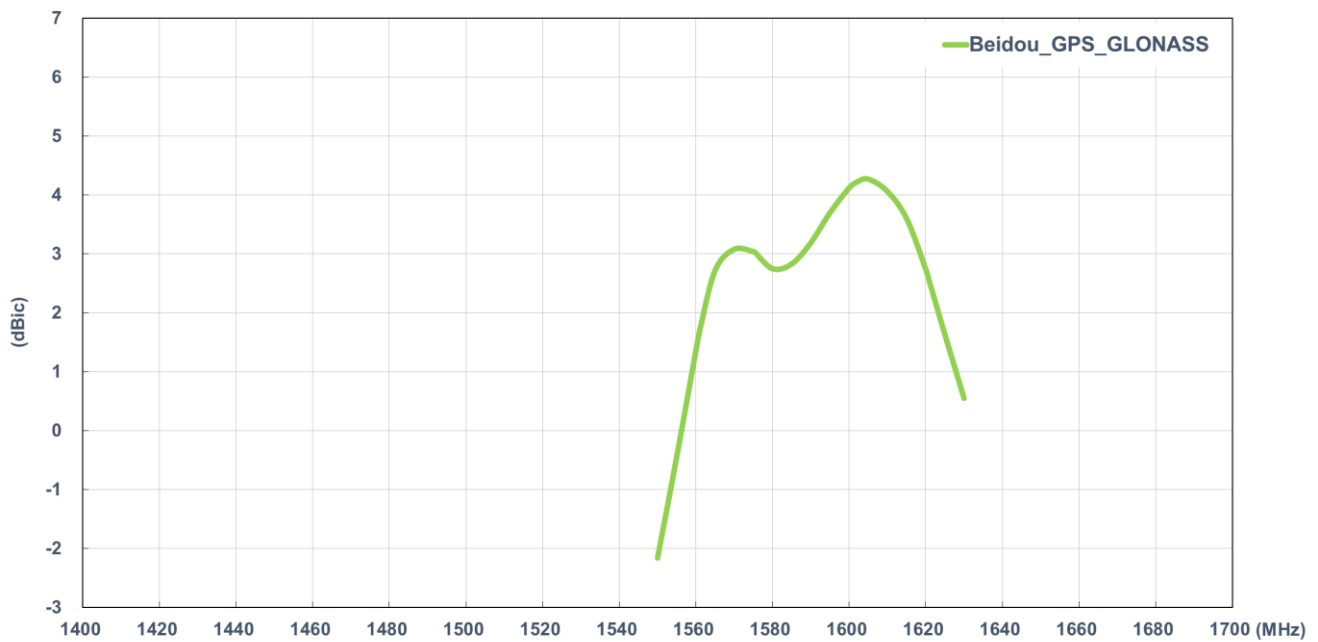

### 3.12 Peak Gain – 4G MIMO 1

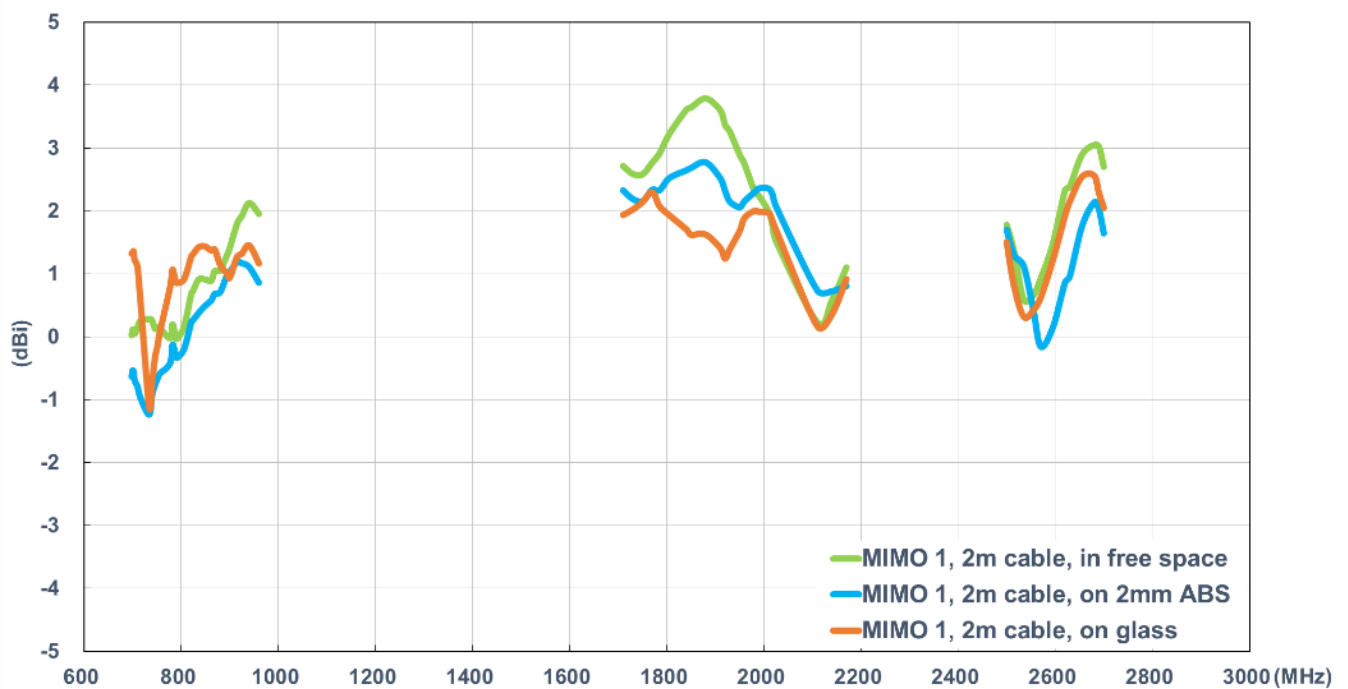



### 3.13 Peak Gain – 4G MIMO 2

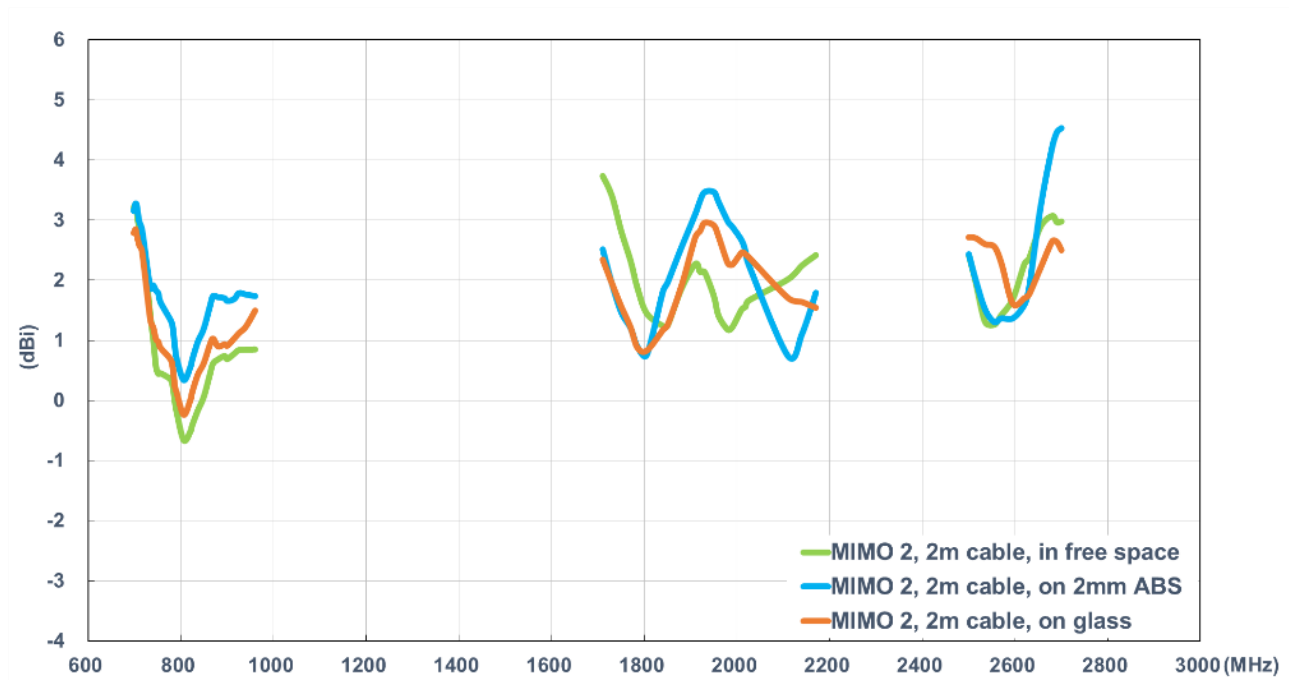

### 3.14 Envelope Correlation Coefficient

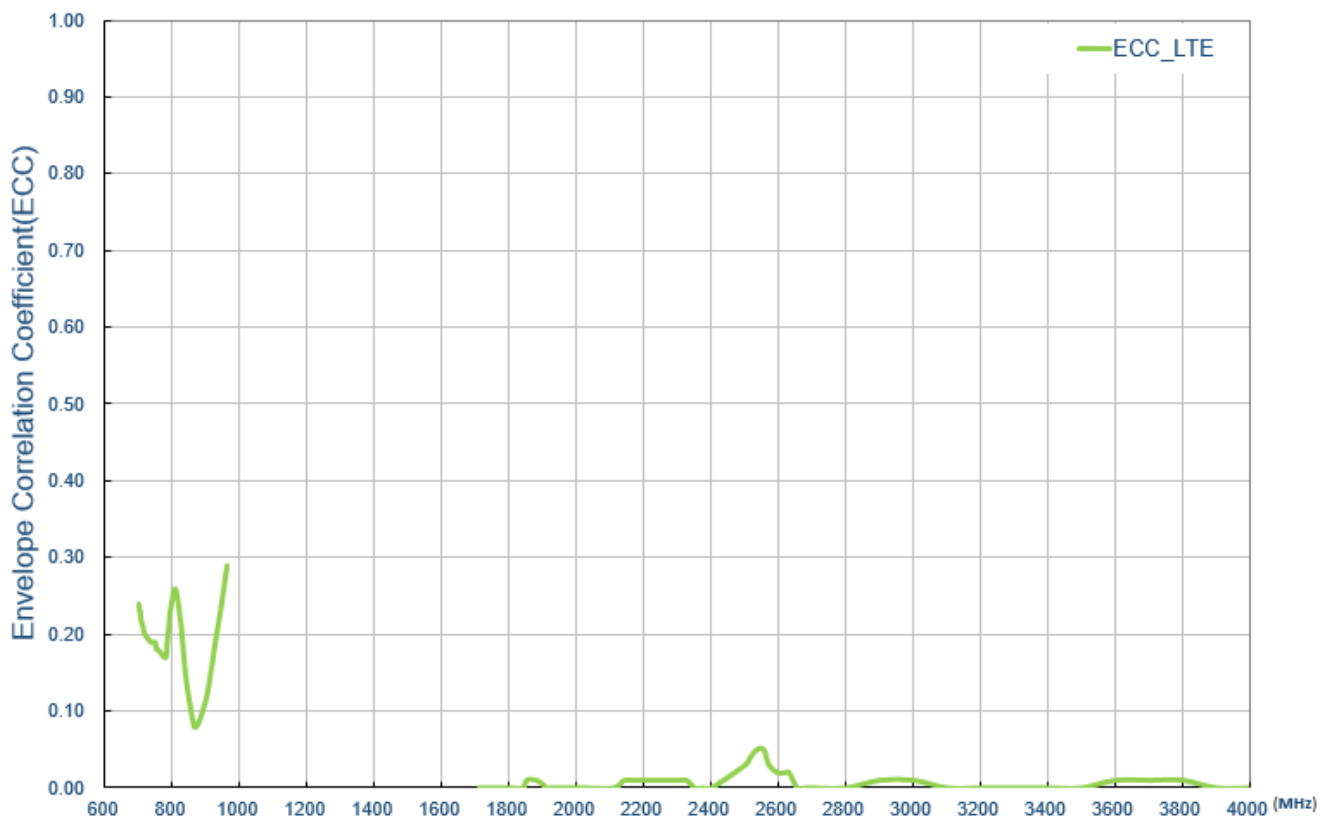

### 3.15 Smith Chart – GNSS

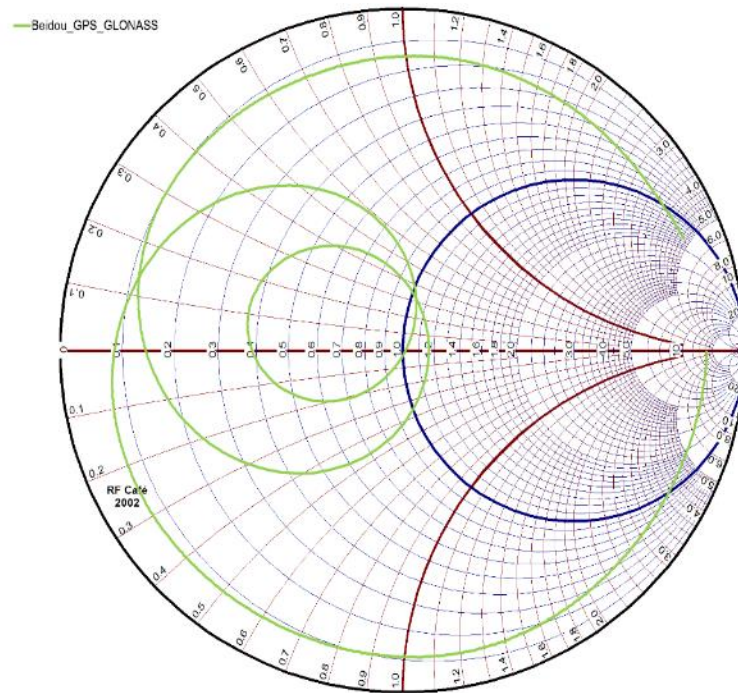

### 3.16 Axial Ratio – BeiDou

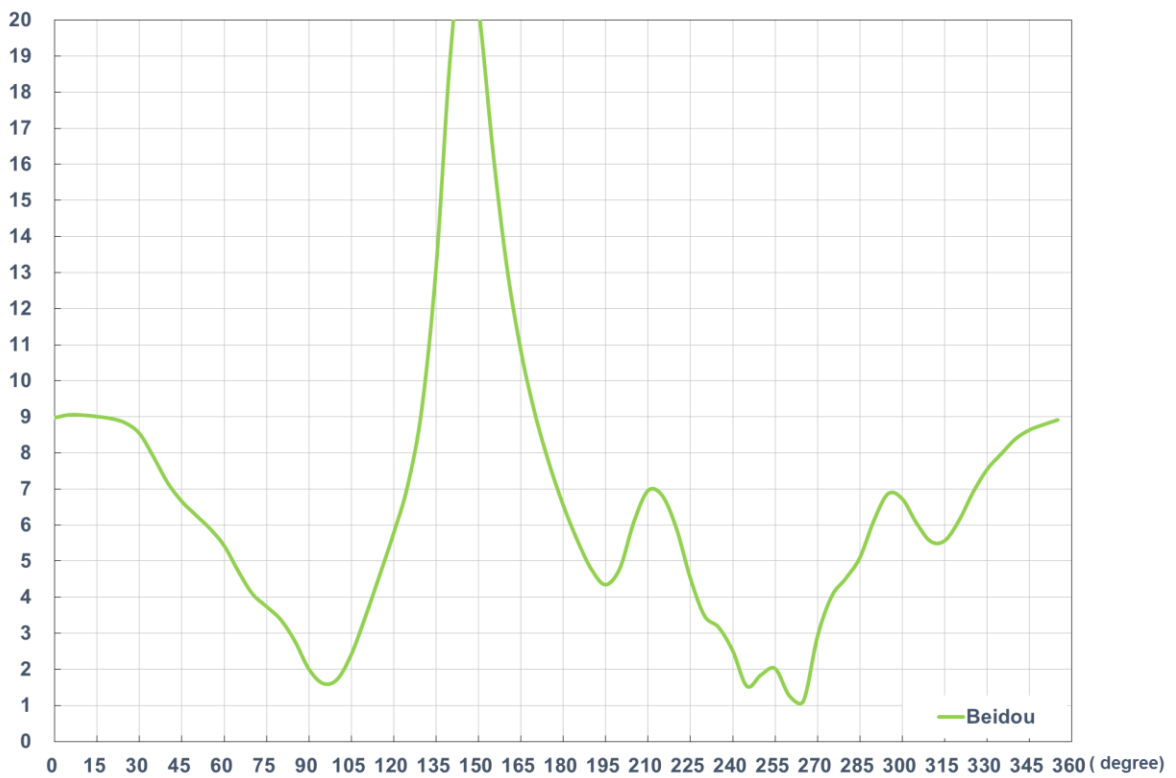

### 3.17 Axial Ratio – GPS/Galileo

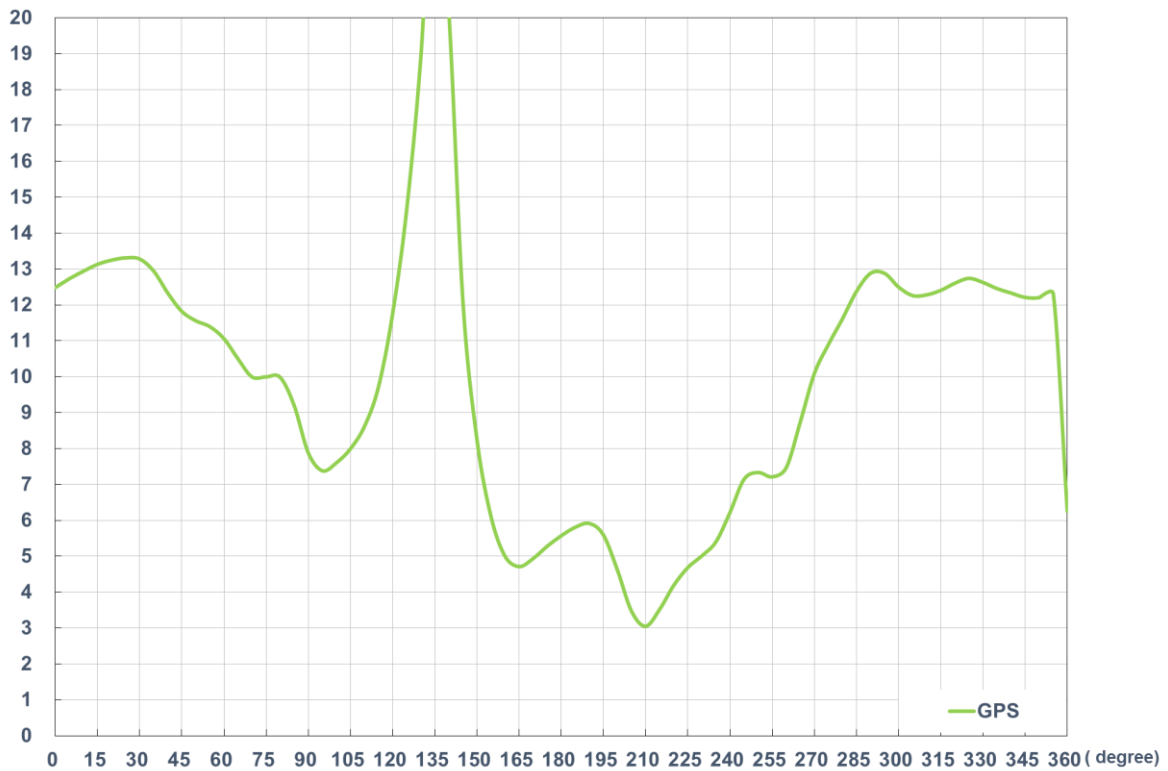

### 3.18 Axial Ratio – GLONASS

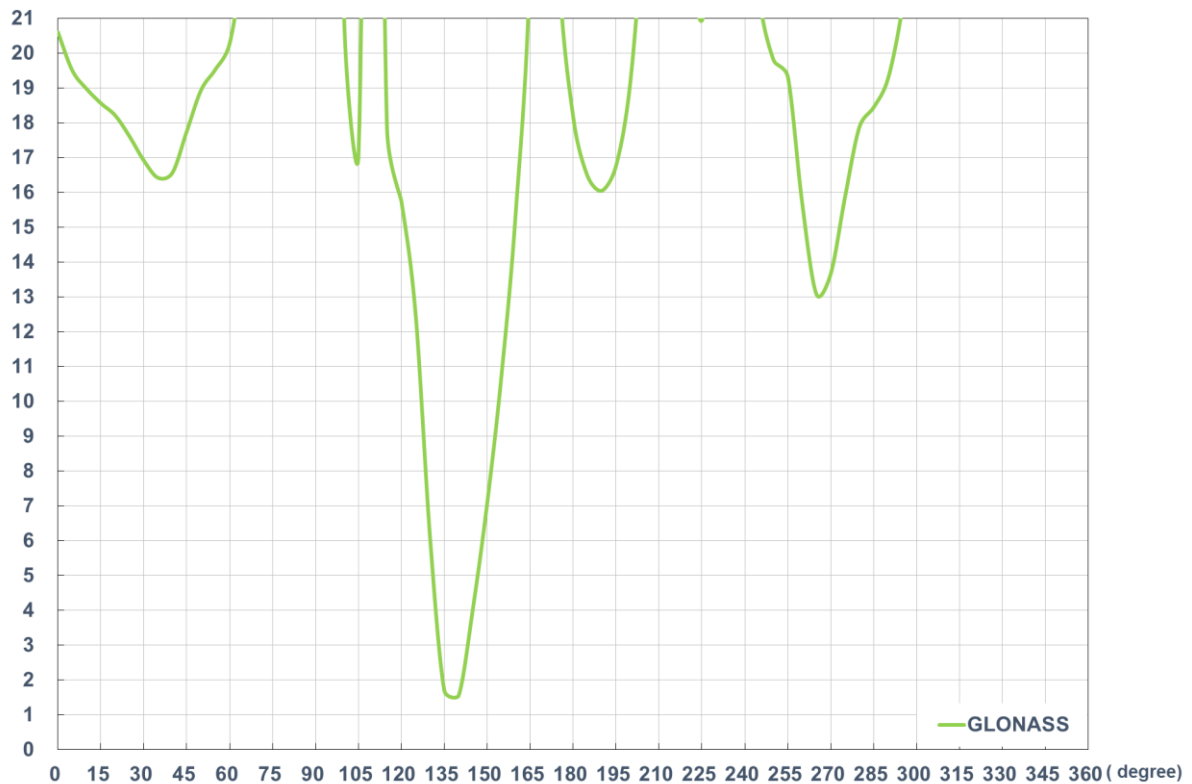

### 3.19 LNA Gain and Noise Figure @ 3V

#### LNA Gain @ 3V

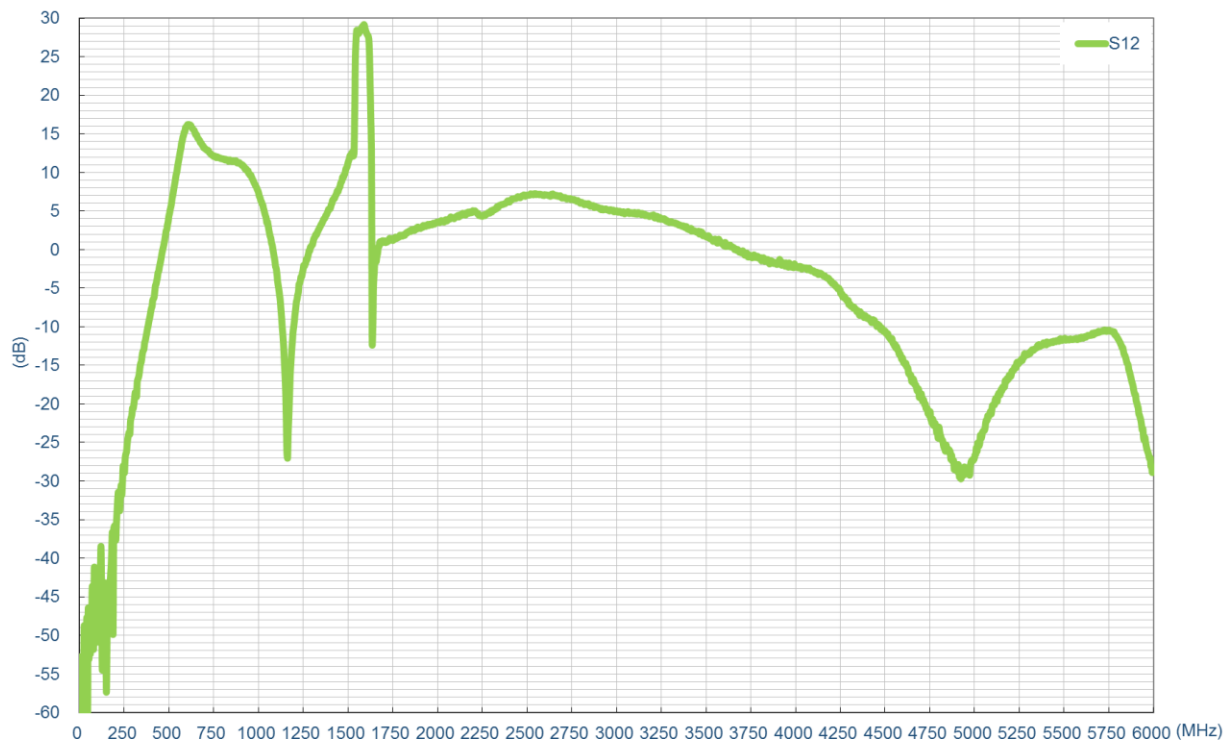

#### LNA Noise @ 3V

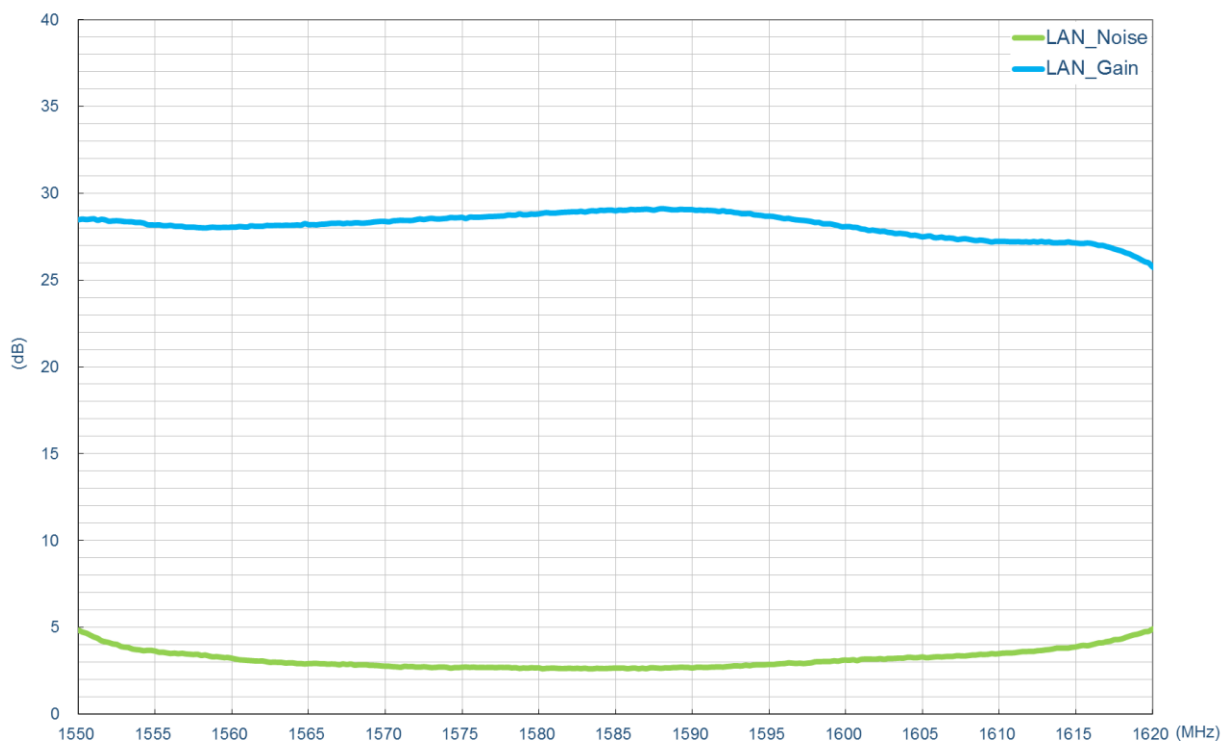

## 4. Radiation Patterns

### 4.1 Test Setup

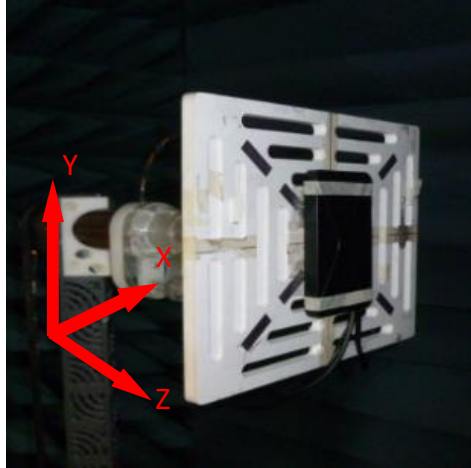

Free Space

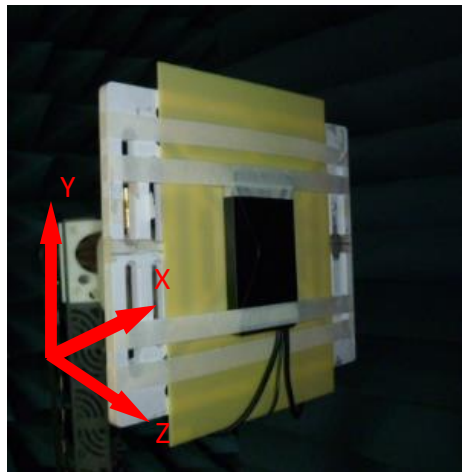

2mm ABS

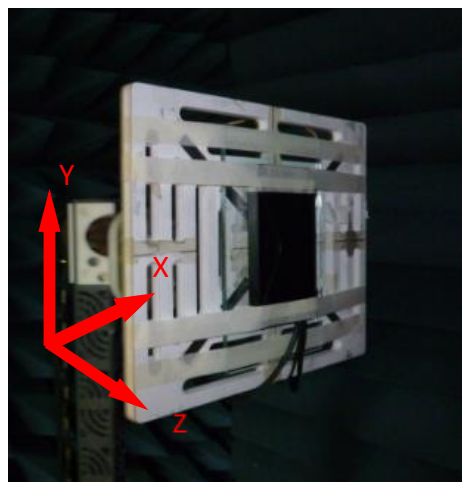

On Glass Base

4.2 GNSS 3D and 2D Radiation Patterns

1575.42MHz

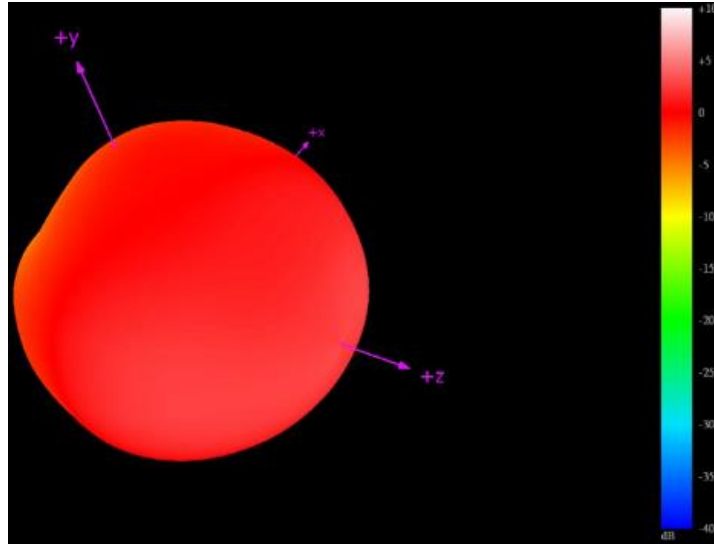

XY Plane

XZ Plane

YZ Plane

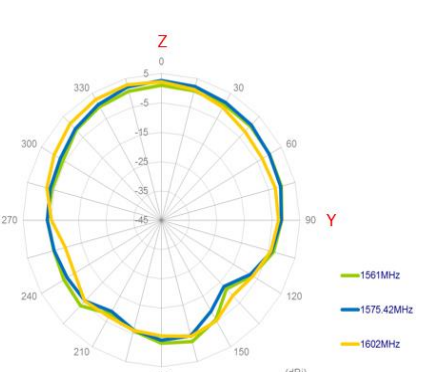
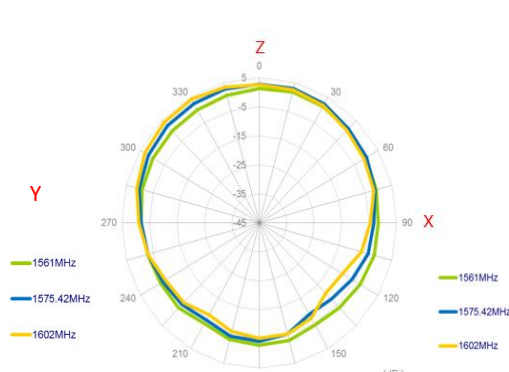
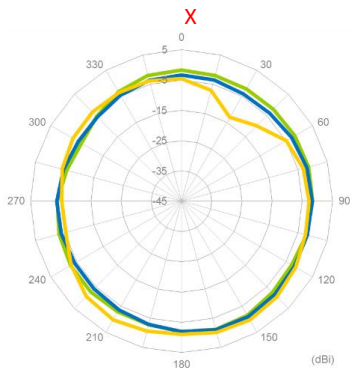

### 4.3 4G MIMO 1 3D and 2D Radiation Patterns – Free Space

704MHz

960MHz

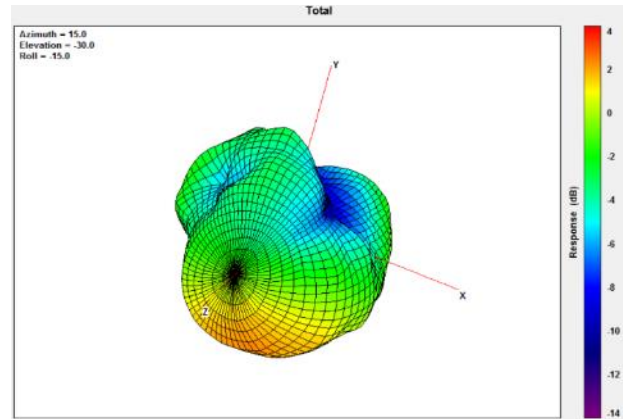
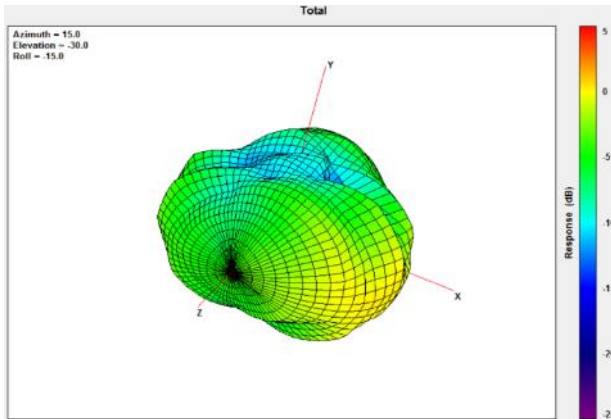

XY Plane

XZ Plane

YZ Plane

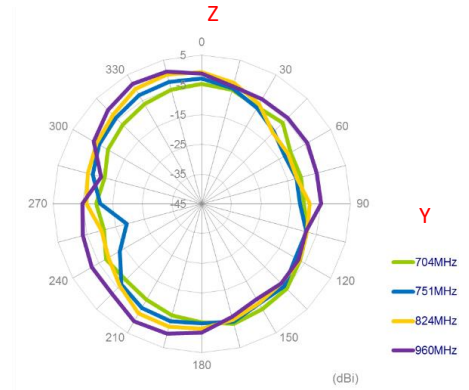
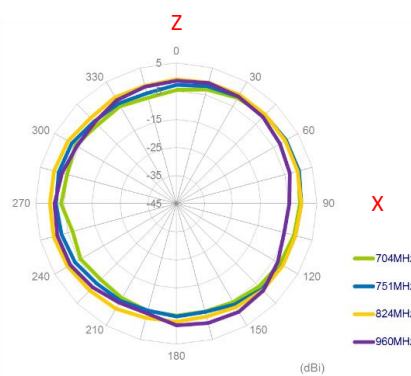
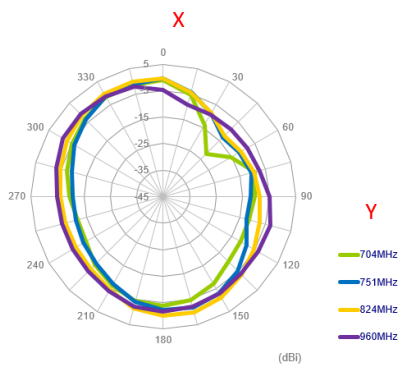

1710MHz

2170MHz

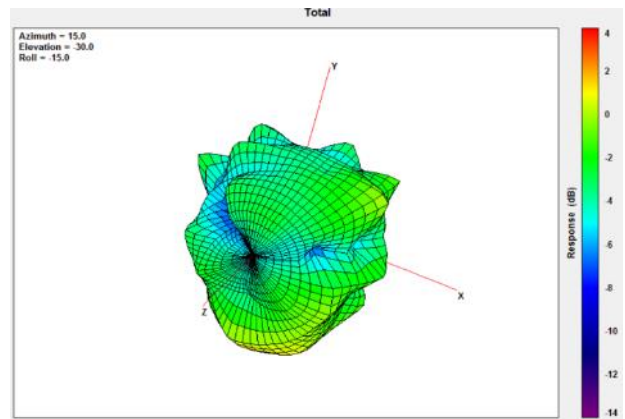
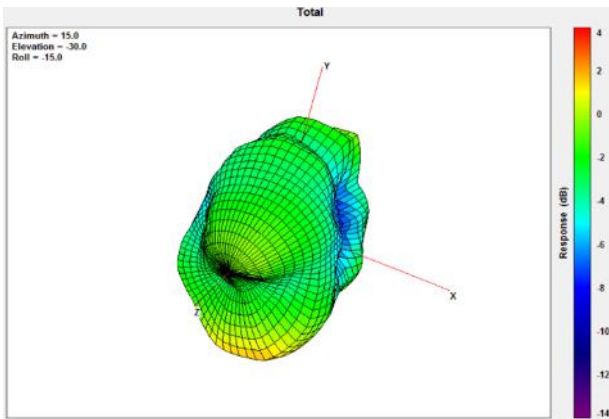

XY Plane

XZ Plane

YZ Plane

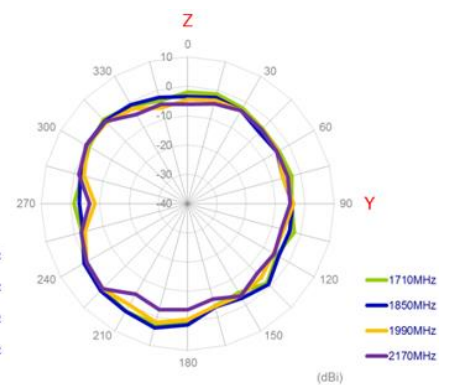
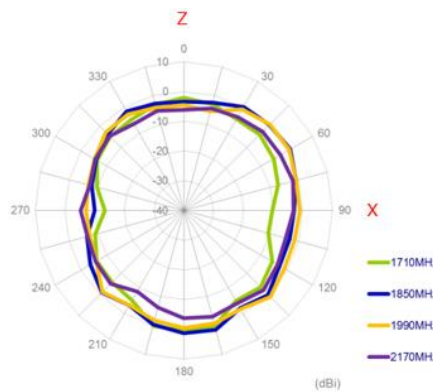
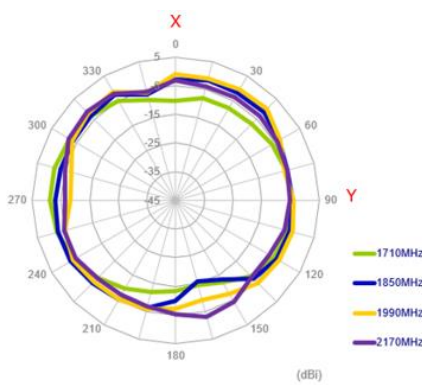



2690MHZ

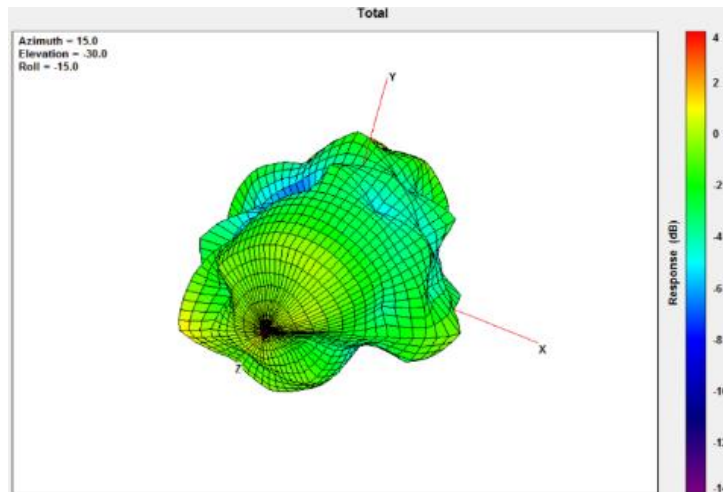

XY Plane

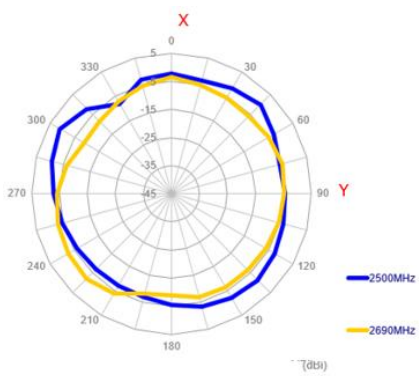

XZ Plane

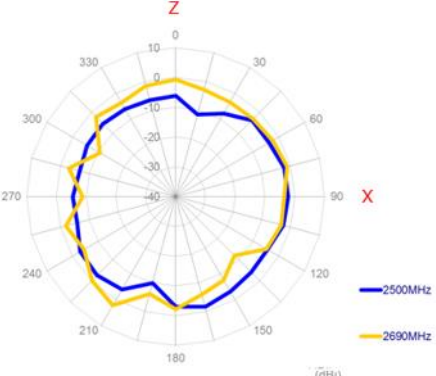

YZ Plane

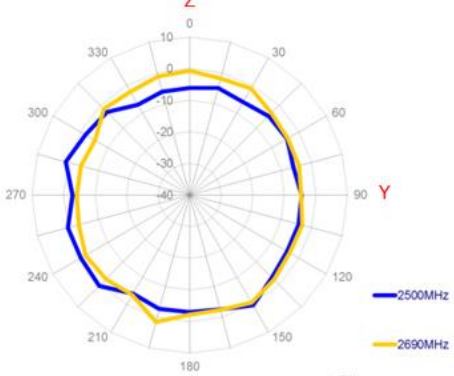

## 4.4 4G MIMO 2 3D and 2D Radiation Patterns – Free Space

704MHz

960MHz

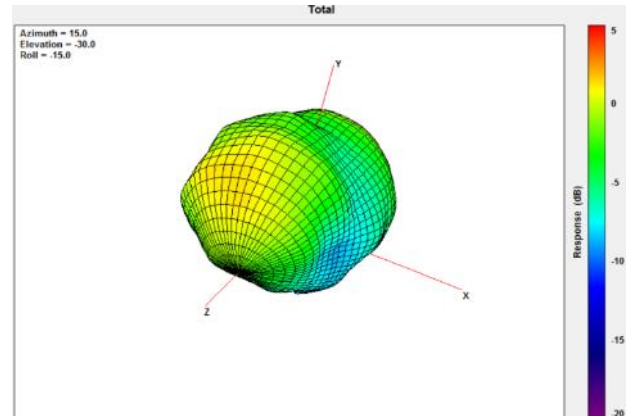
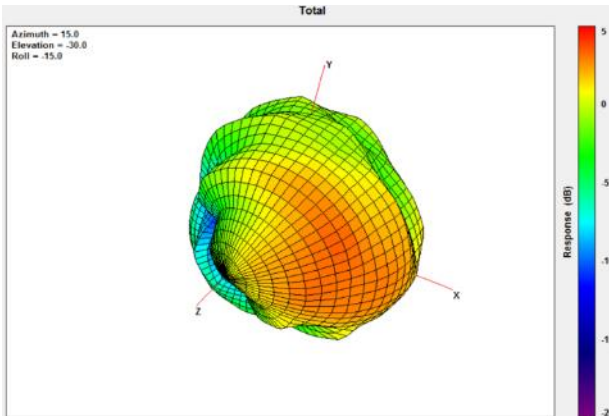

XY Plane

XZ Plane

YZ Plane

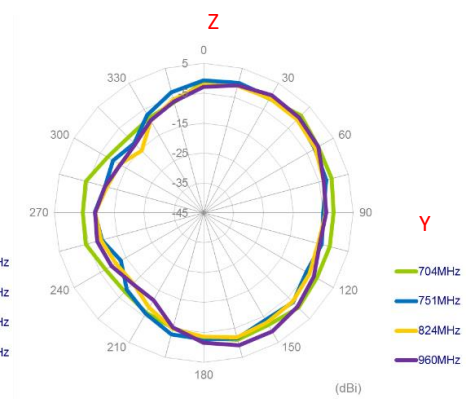
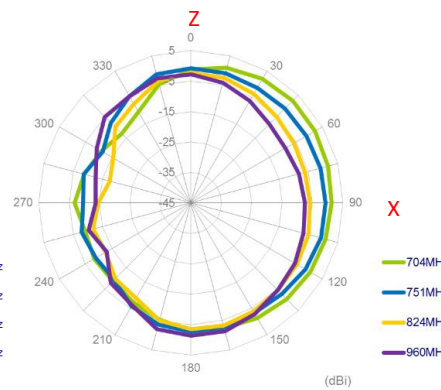
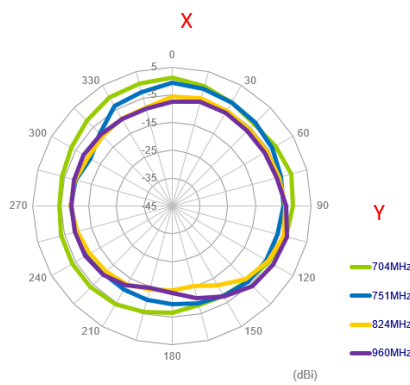

## 1710MHz

## 2170MHz

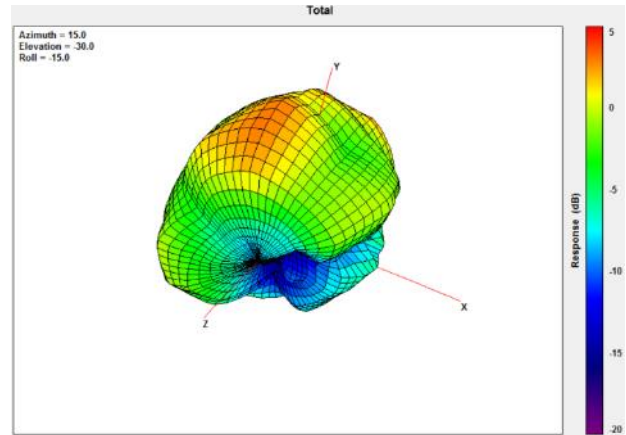
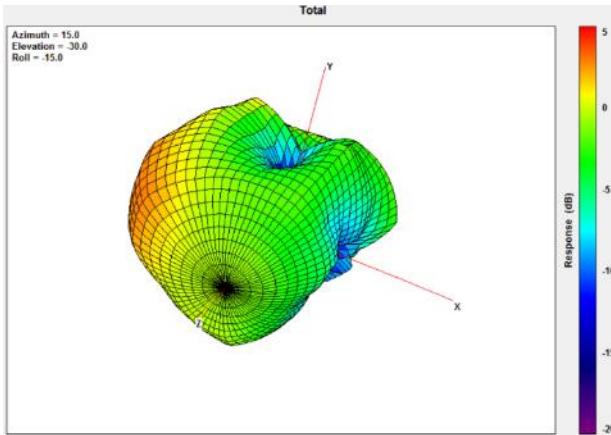

### XY Plane

### XZ Plane

### YZ Plane

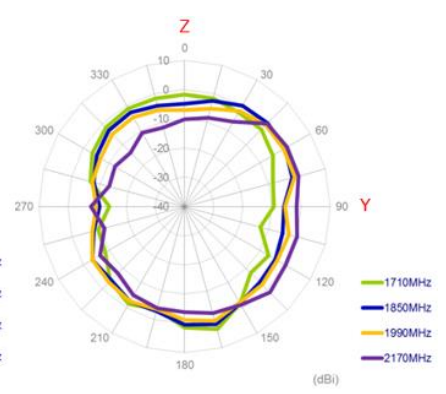
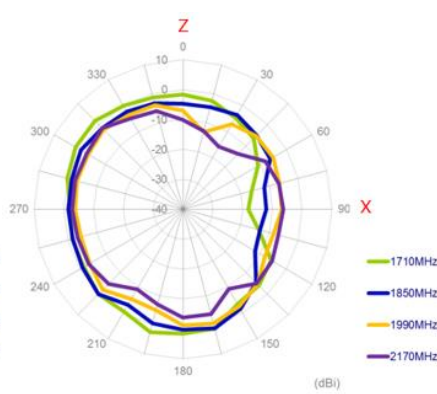
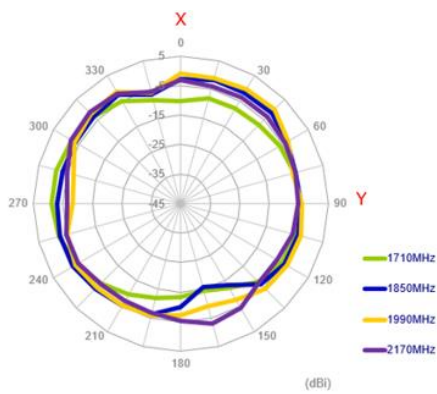

2690MHZ

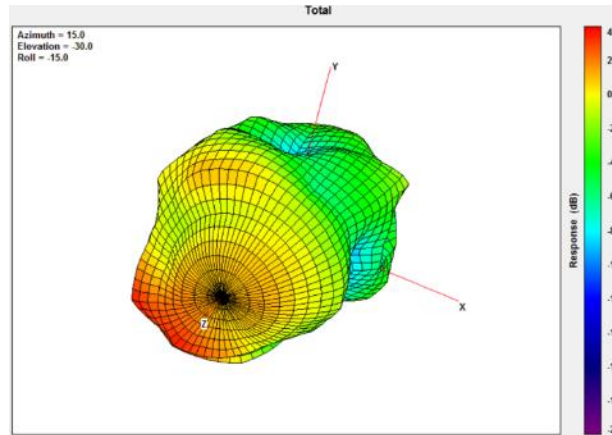

XY Plane

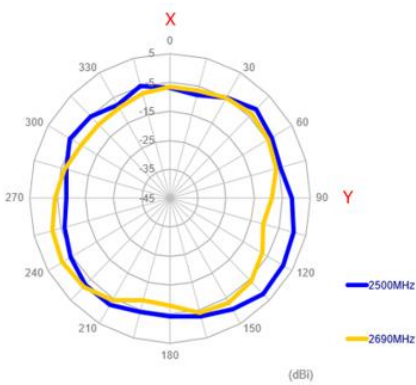

XZ Plane

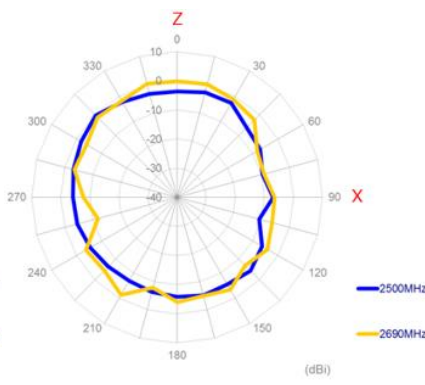

YZ Plane

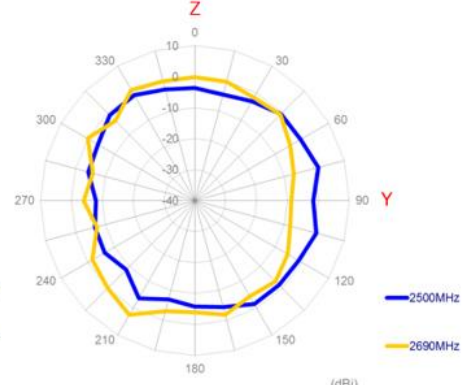

### 4.3 4G MIMO 1 3D and 2D Radiation Patterns – 2mm ABS

704MHz

960MHz

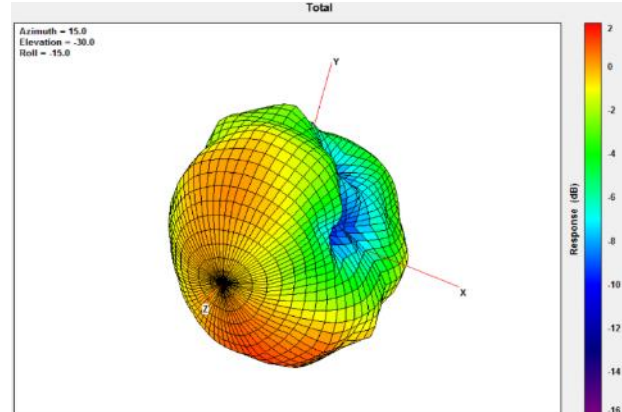
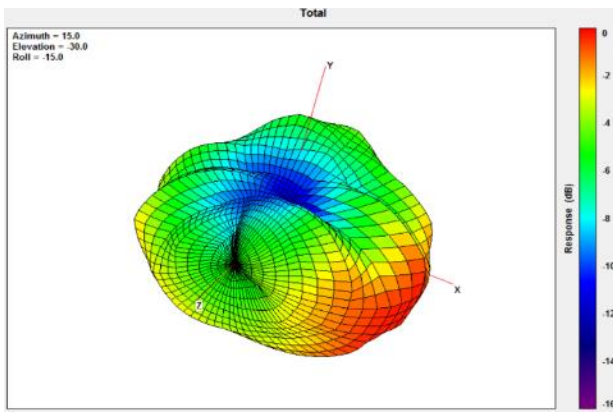

XY Plane

XZ Plane

YZ Plane

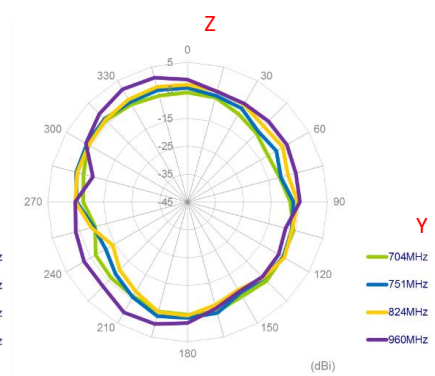
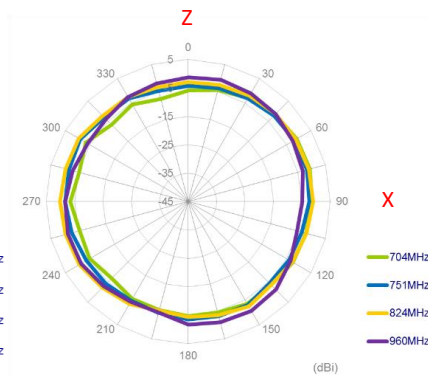
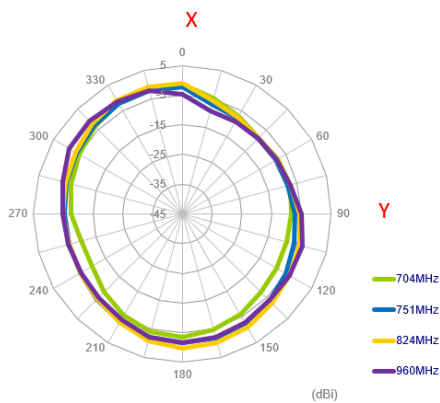

**1710MHz** **2170MHz**

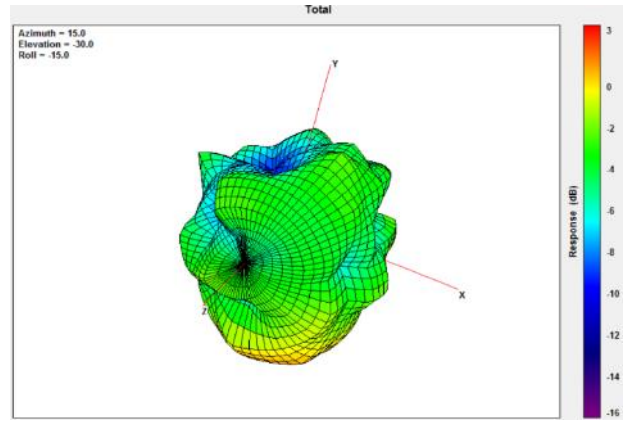
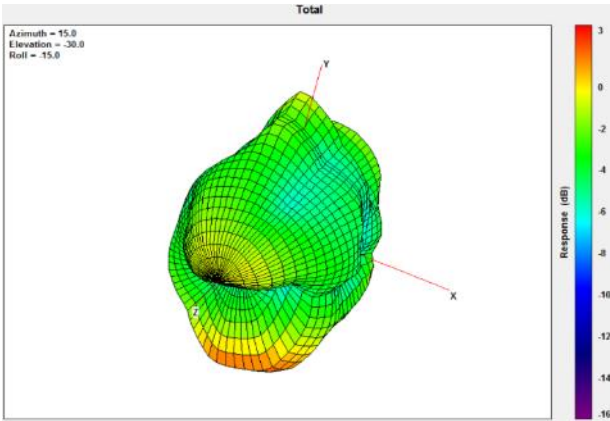

**XY Plane**

**XZ Plane**

**YZ Plane**

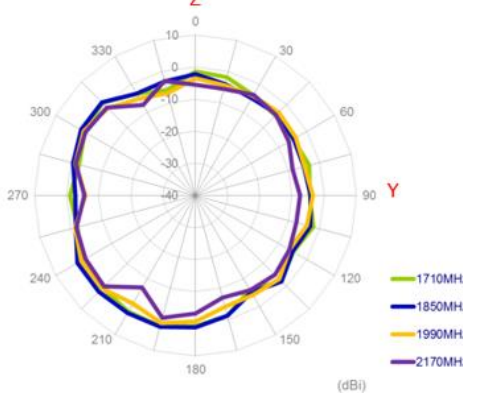
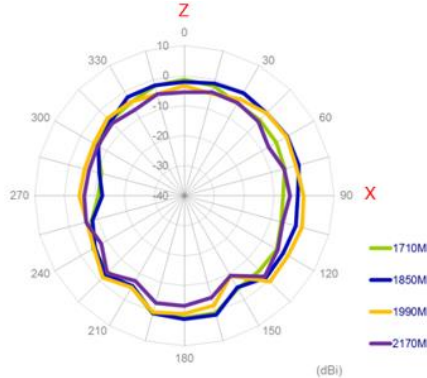
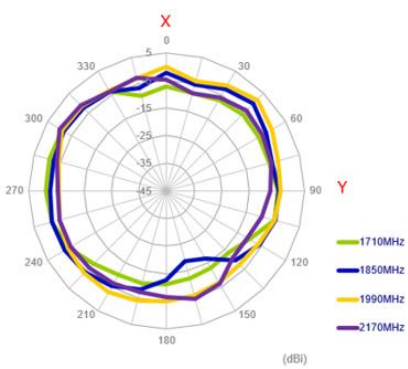

2690MHZ

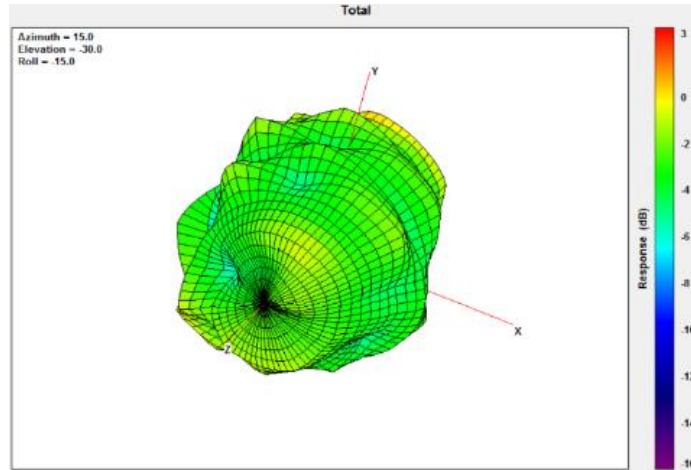

XY Plane

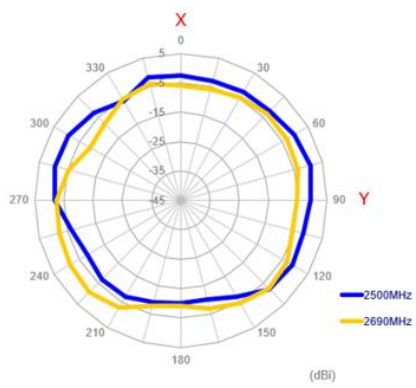

XZ Plane

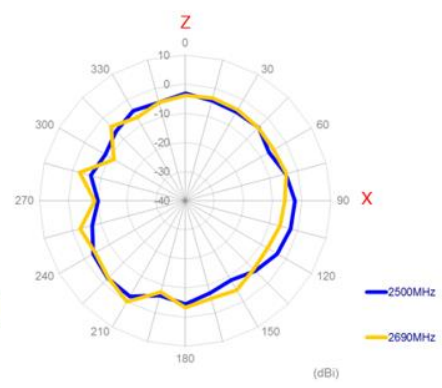

YZ Plane

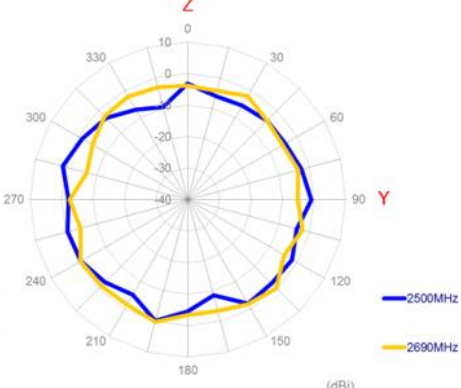

## 4.4 4G MIMO 2 3D and 2D Radiation Patterns – 2mm ABS

704MHz

960MHz

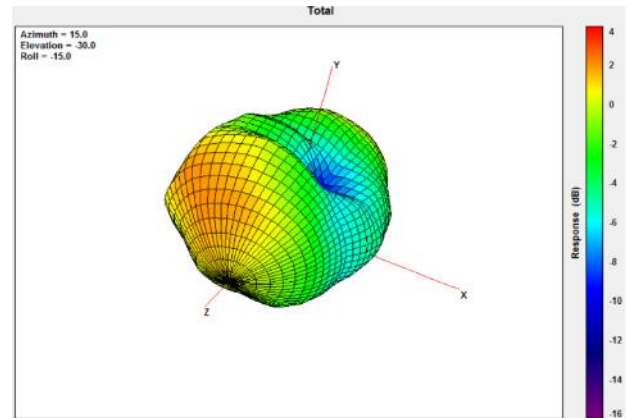
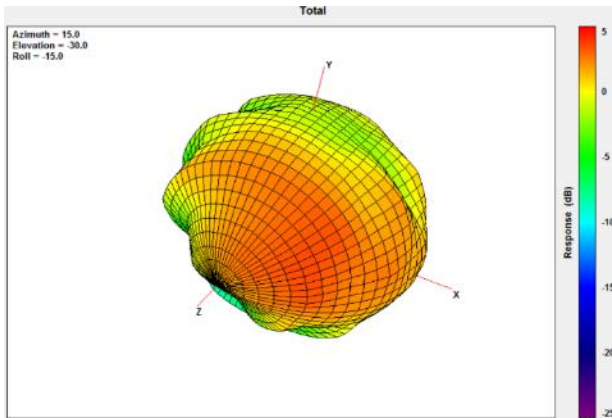

XY Plane

XZ Plane

YZ Plane

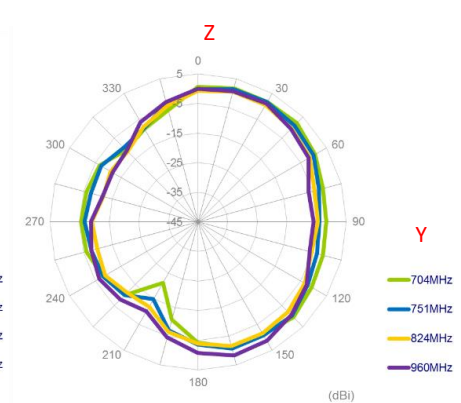
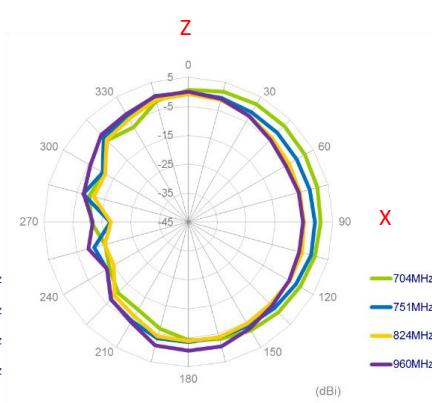
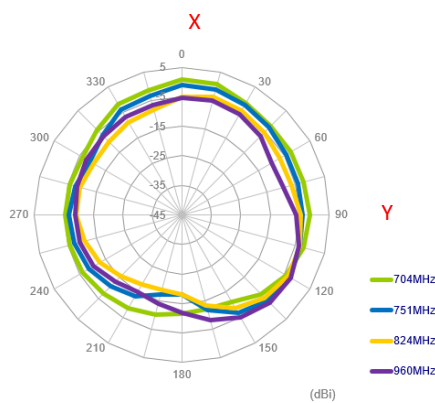



1710MHz 2170MHz

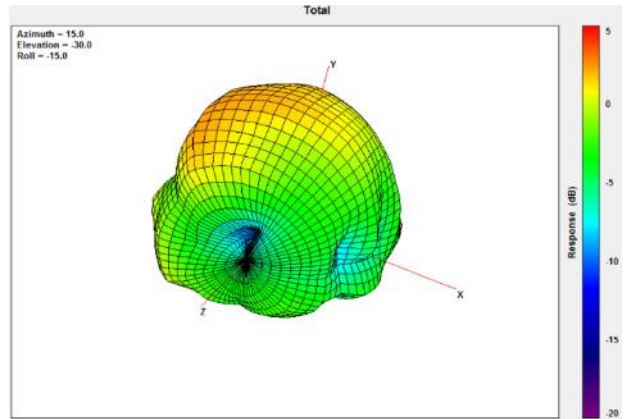
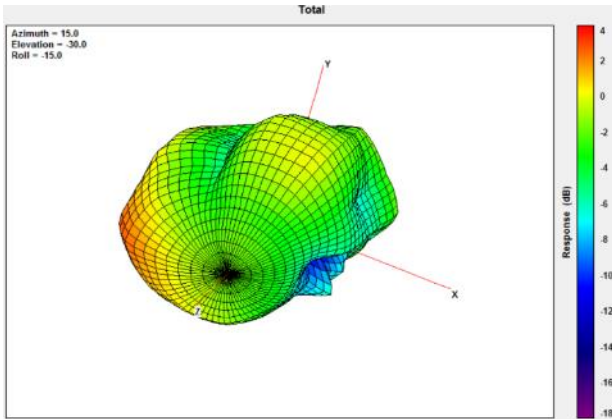

XY Plane

XZ Plane

YZ Plane

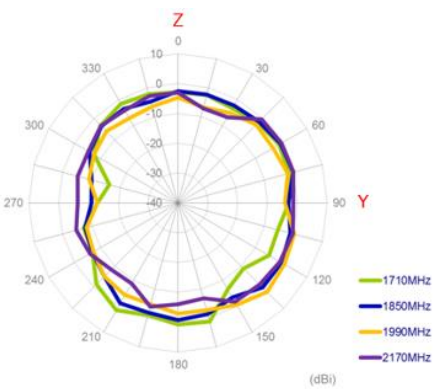
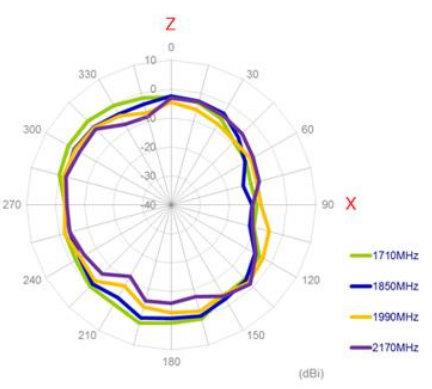
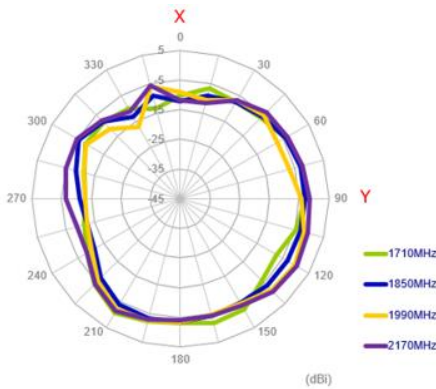

2690MHZ

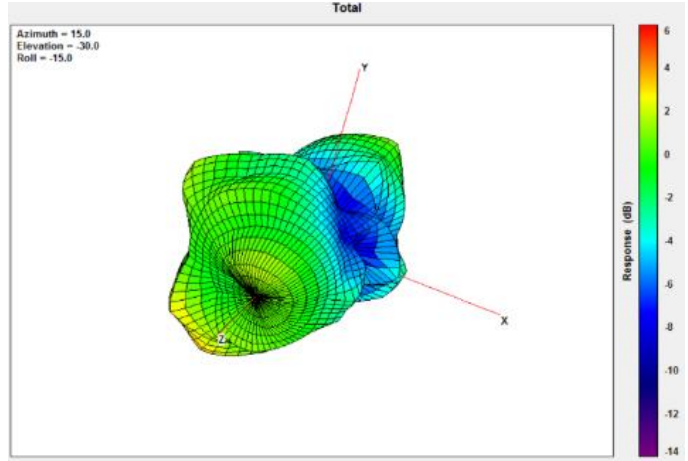

XY Plane

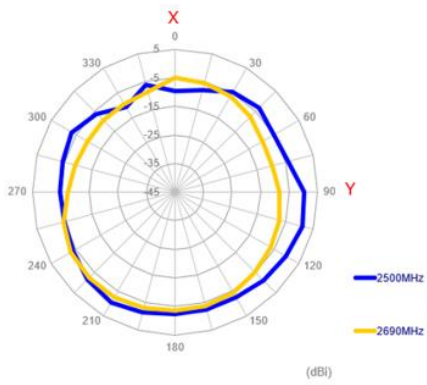

XZ Plane

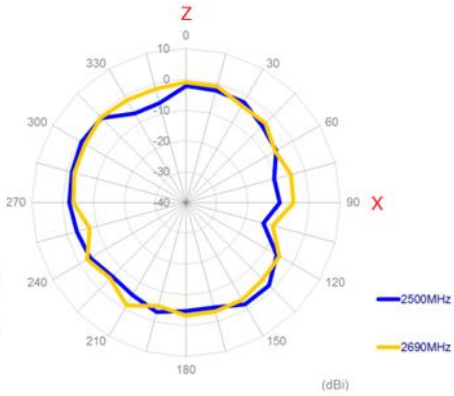

YZ Plane

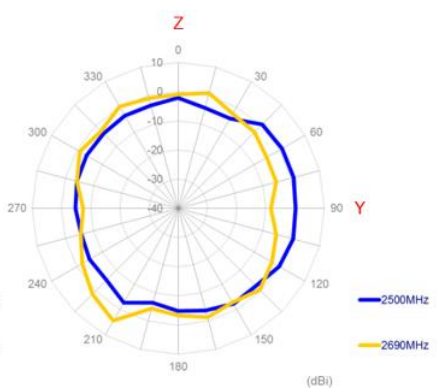

### 4.3 4G MIMO 1 3D and 2D Radiation Patterns – On Glass

704MHz

960MHz

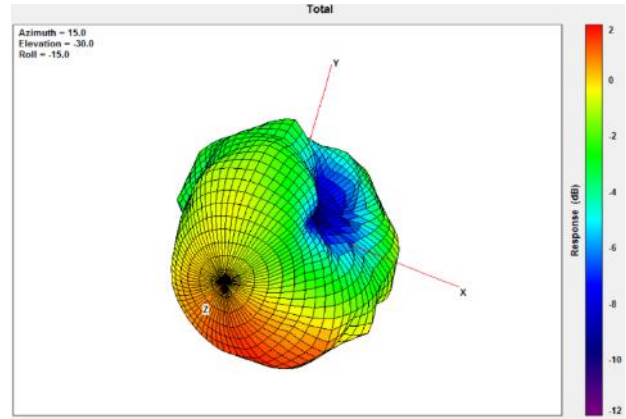
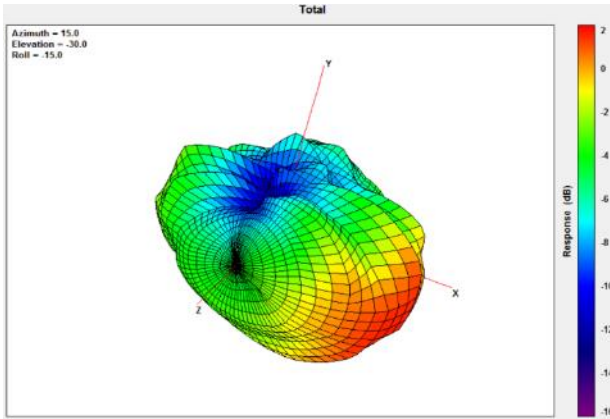

XY Plane

XZ Plane

YZ Plane

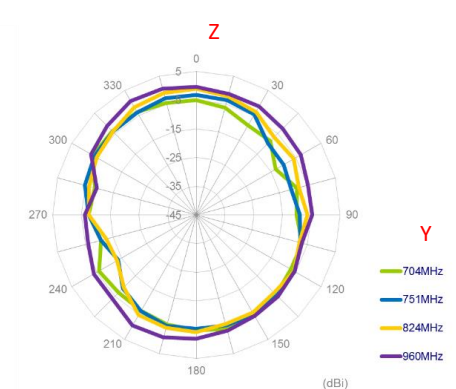
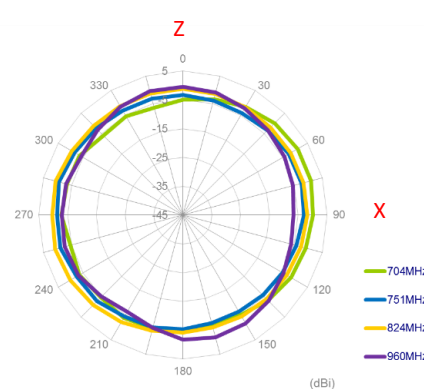
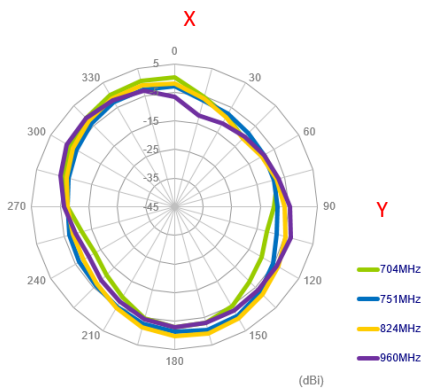

**1710MHz** **2170MHz**

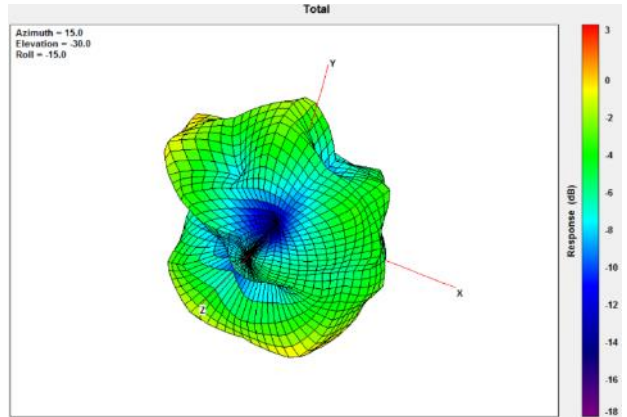
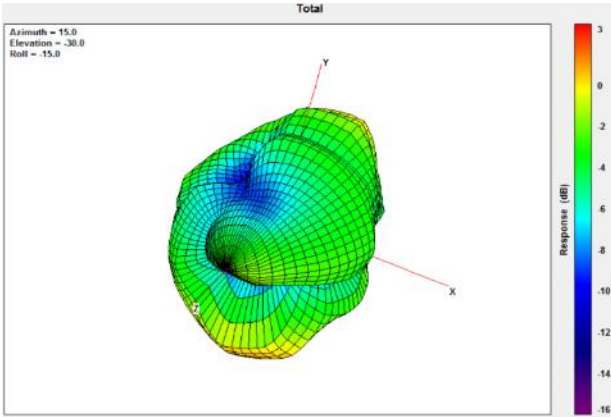

**XY Plane**

**XZ Plane**

**YZ Plane**

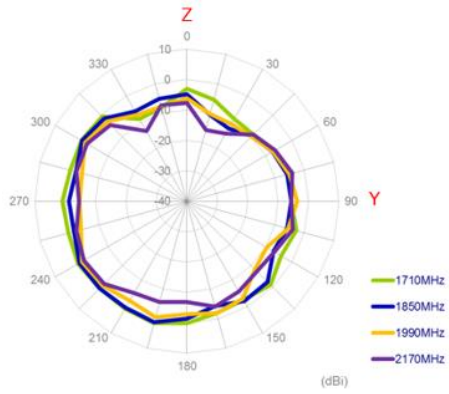
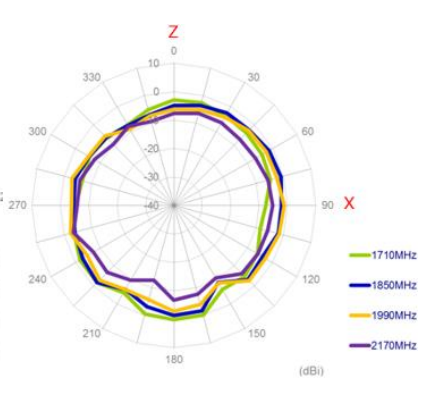
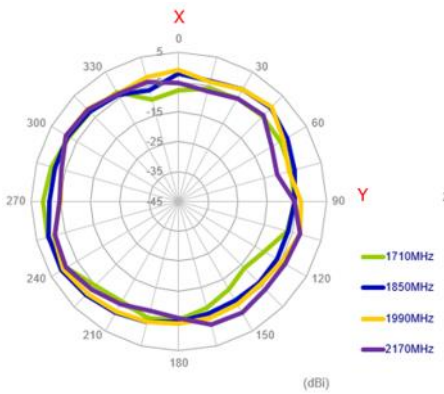

2690MHZ

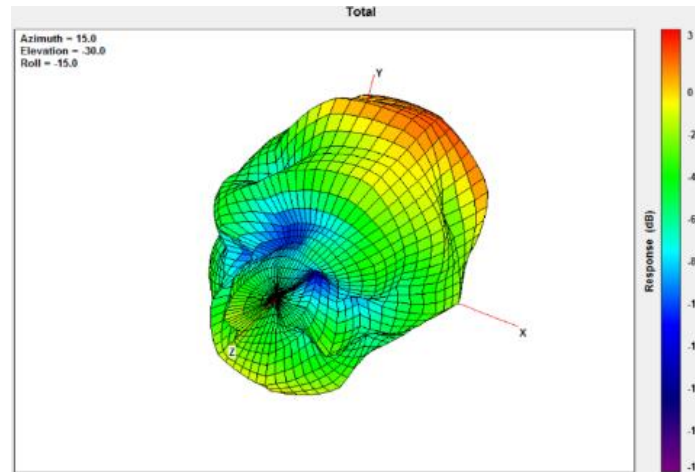

XY Plane

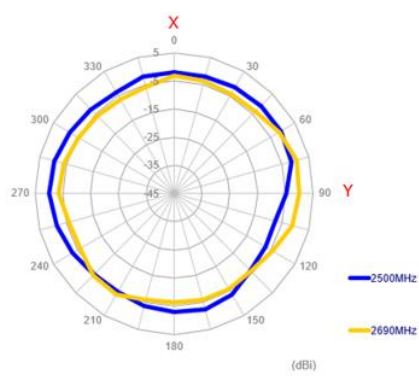

XZ Plane

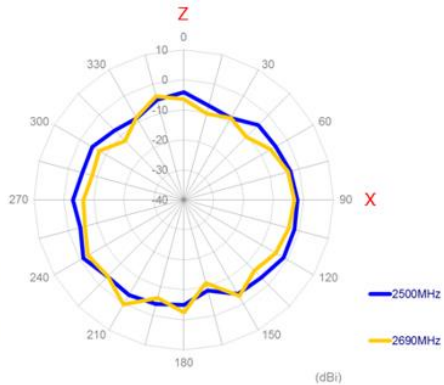

YZ Plane

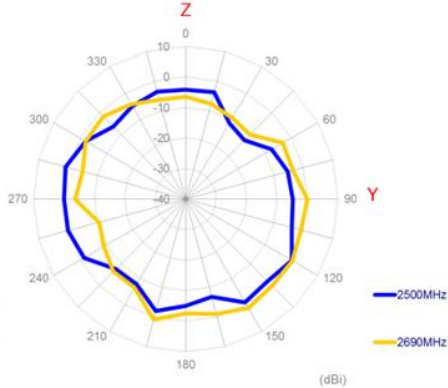

## 4.4 4G MIMO 2 3D and 2D Radiation Patterns – 2mm ABS

704MHz

960MHz

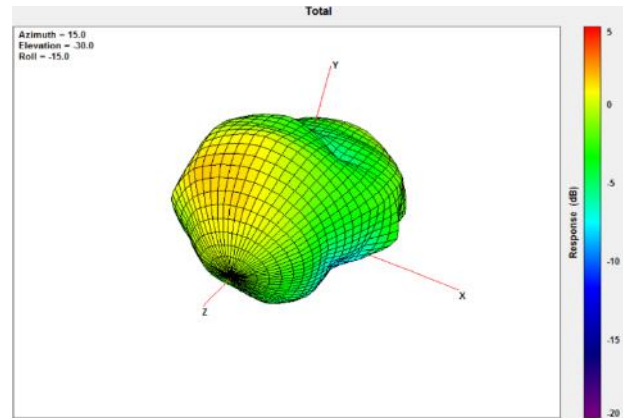
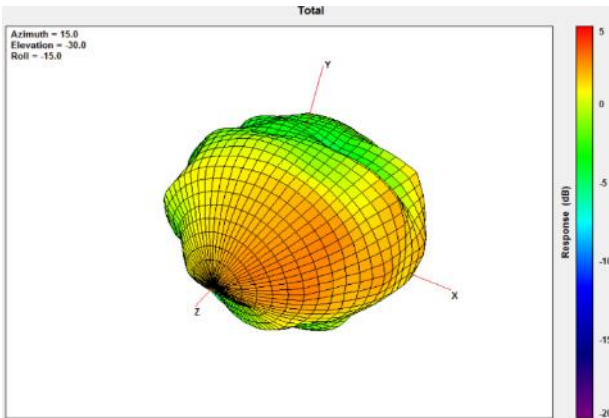

XY Plane

XZ Plane

YZ Plane

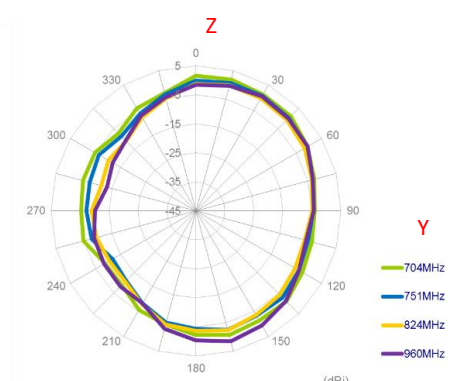
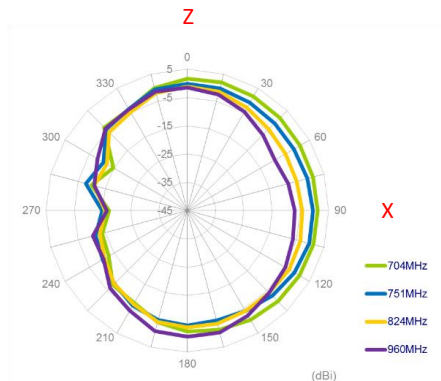
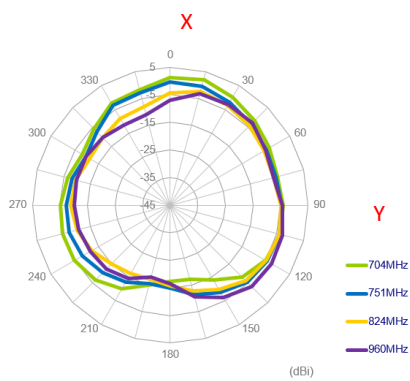

1710MHz 2170MHz

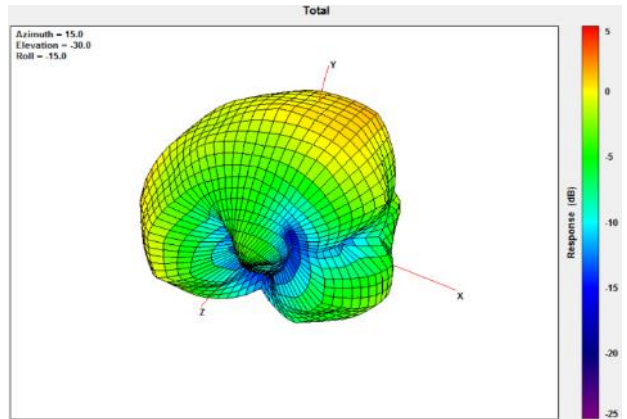
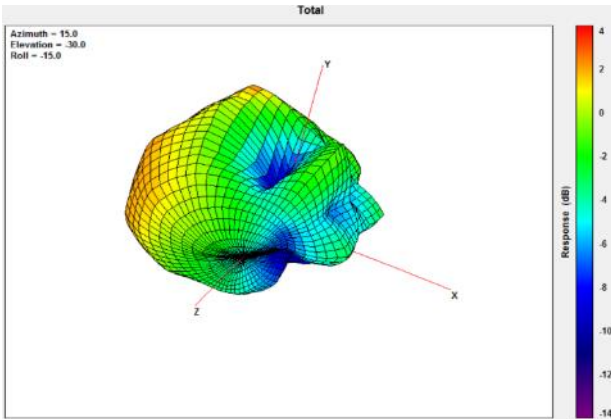

XY Plane

XZ Plane

YZ Plane

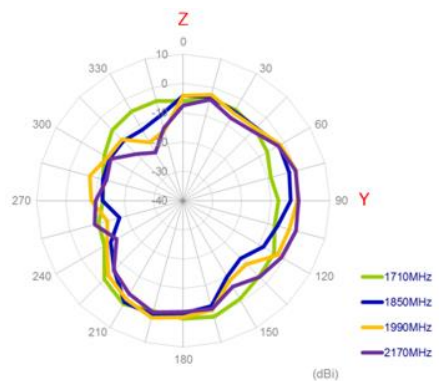
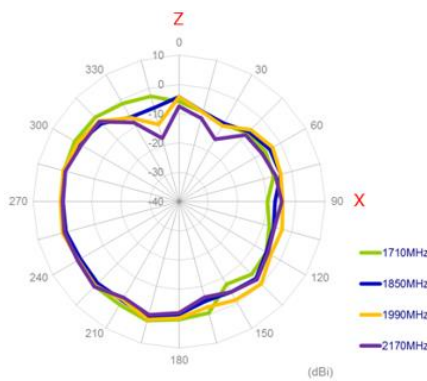
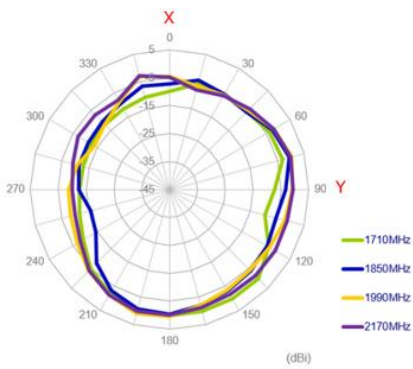

2690MHZ

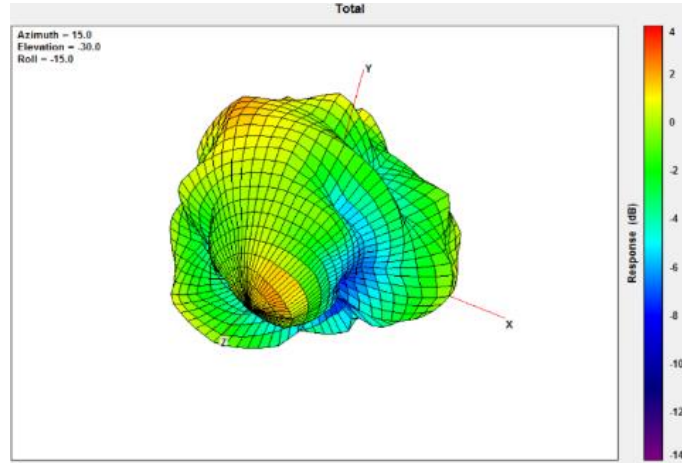

XY Plane

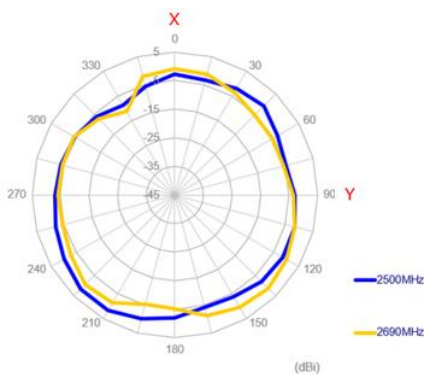

XZ Plane

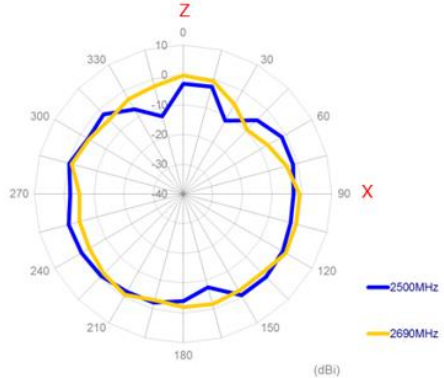

YZ Plane

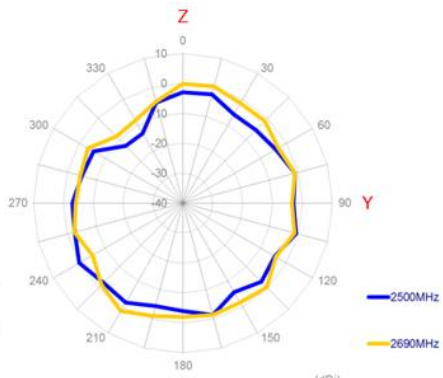



# 5. Mechanical Drawing (Units: mm)

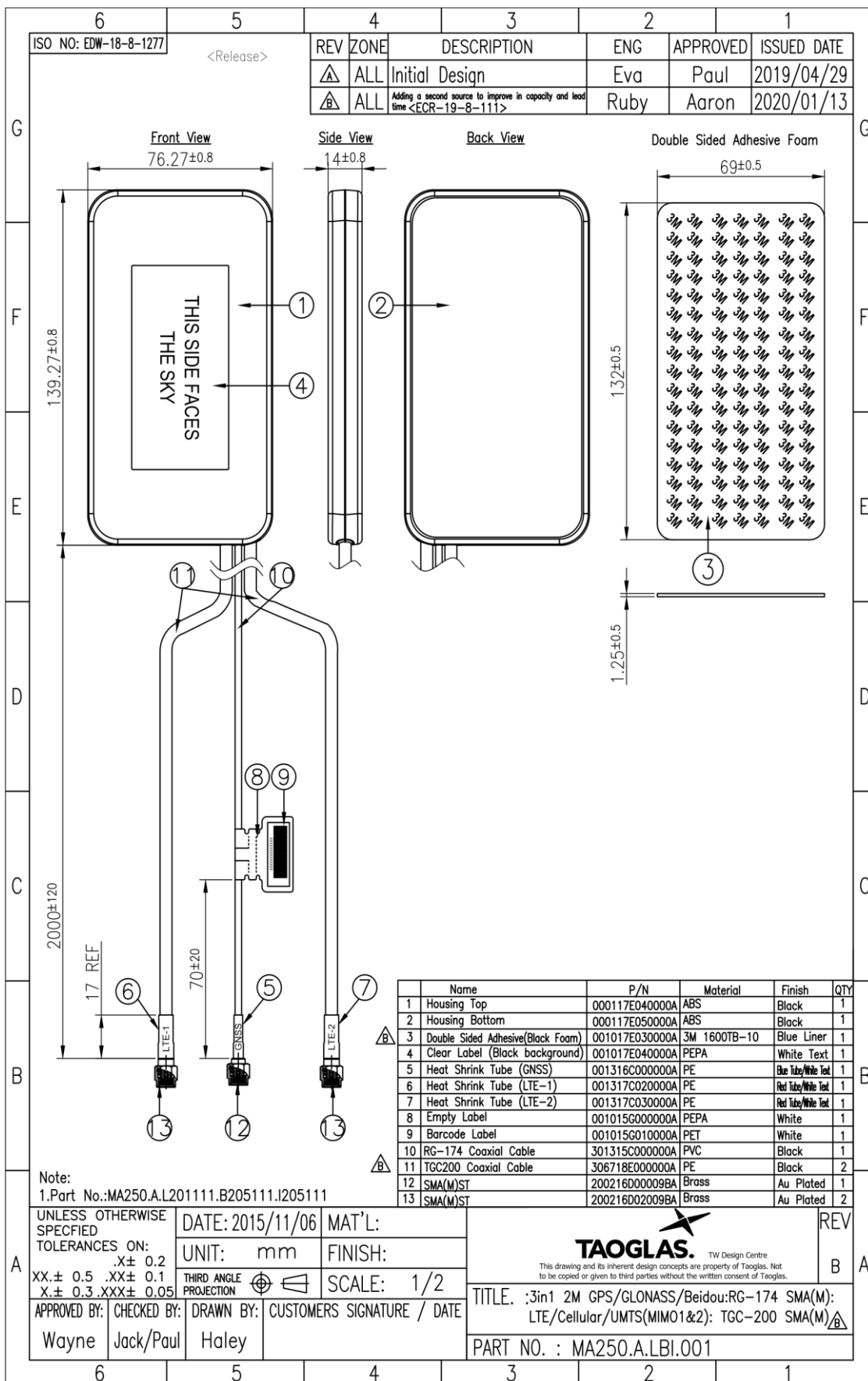

## 6. Packaging

1 pc MA250.A.LBI.003 per PE bag  
 Dimensions - 300\*200mm  
 Total Weight - 410g

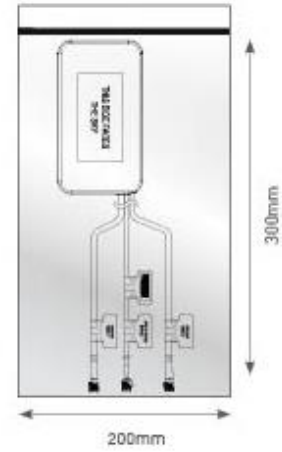

20 pcs MA250.A.LBI.003 per carton  
 Carton Dimensions - 740\*370\*300mm  
 Weight - 8.7kg

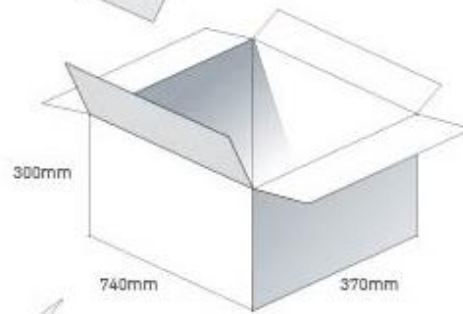

Pallet Dimensions 1200\*1000\*1400mm  
 12 Cartons per pallet  
 6 Cartons per layer  
 2 Layers

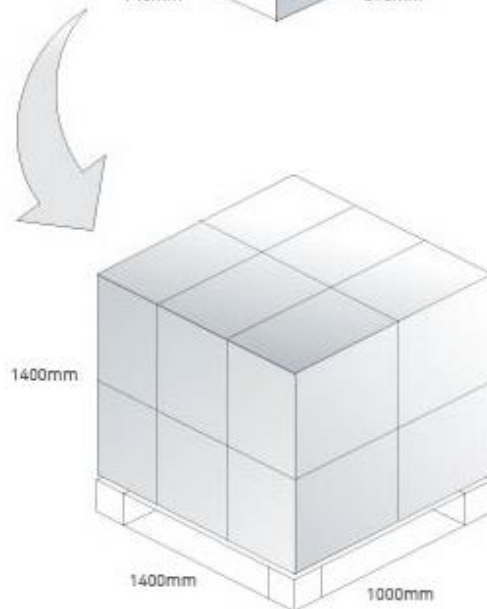

## 7. Application Note

The antenna was tested with different cable lengths and various base mounting options to indicate its performance to act as a reference for the customer's design .

### 7.1 Return Loss – Free Space MIMO 1

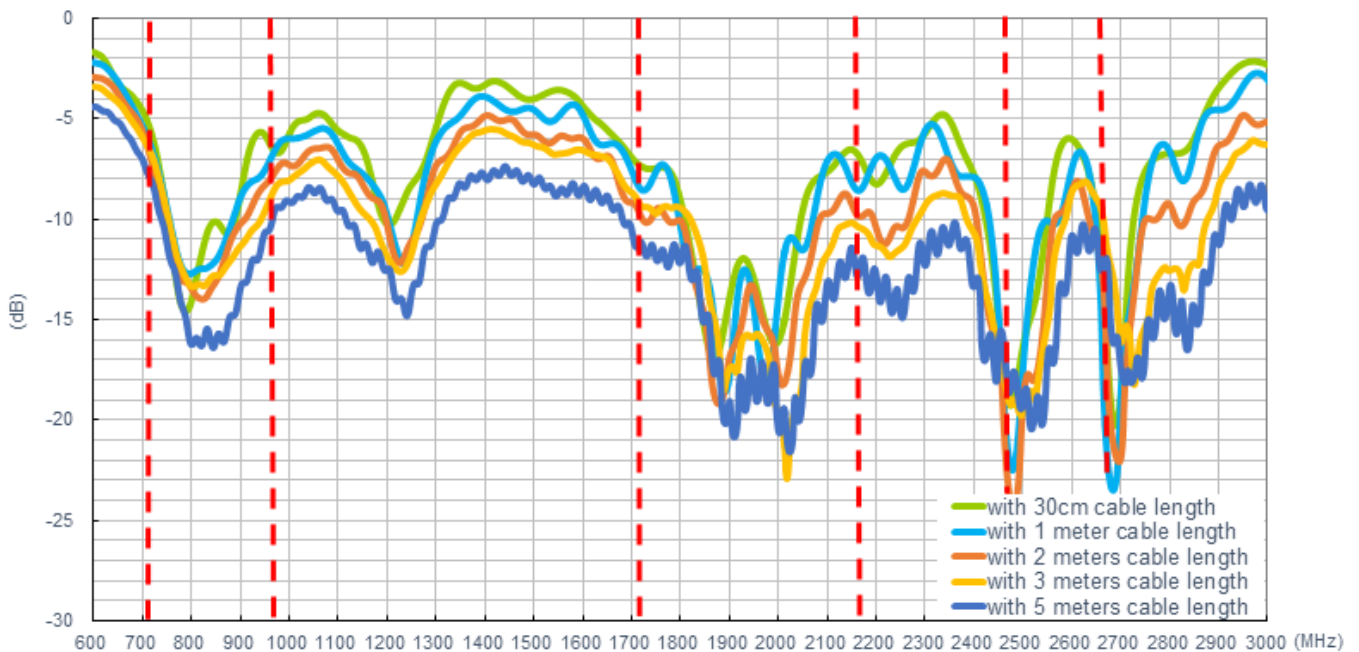

### 7.2 Efficiency – Free Space MIMO 1

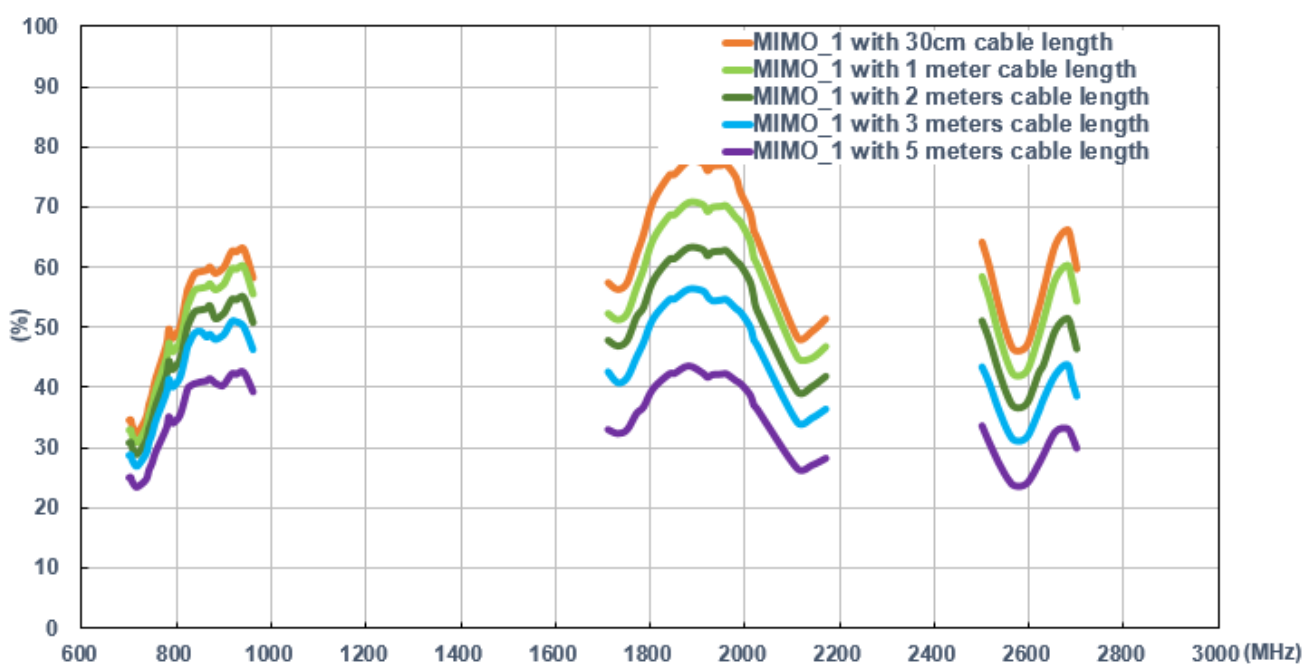

### 7.3 Average Gain – Free Space MIMO 1

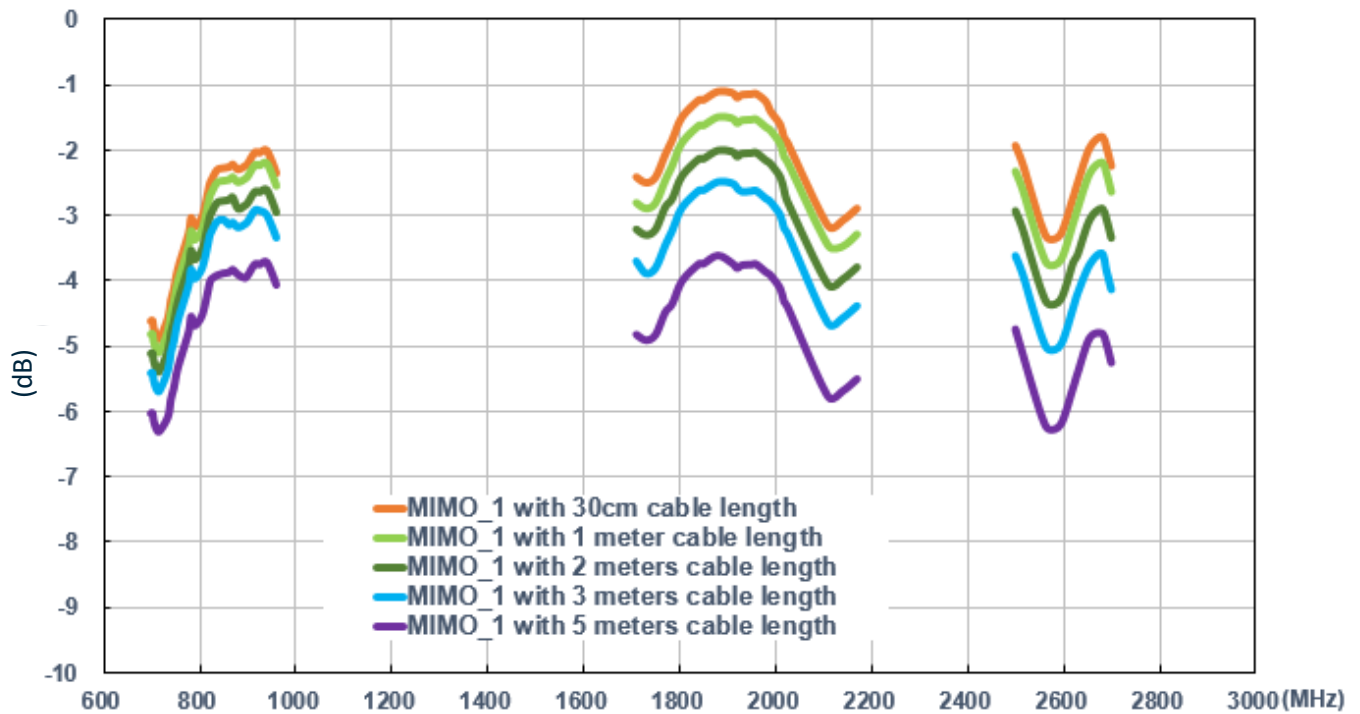

### 7.4 Peak Gain – Free Space MIMO 1

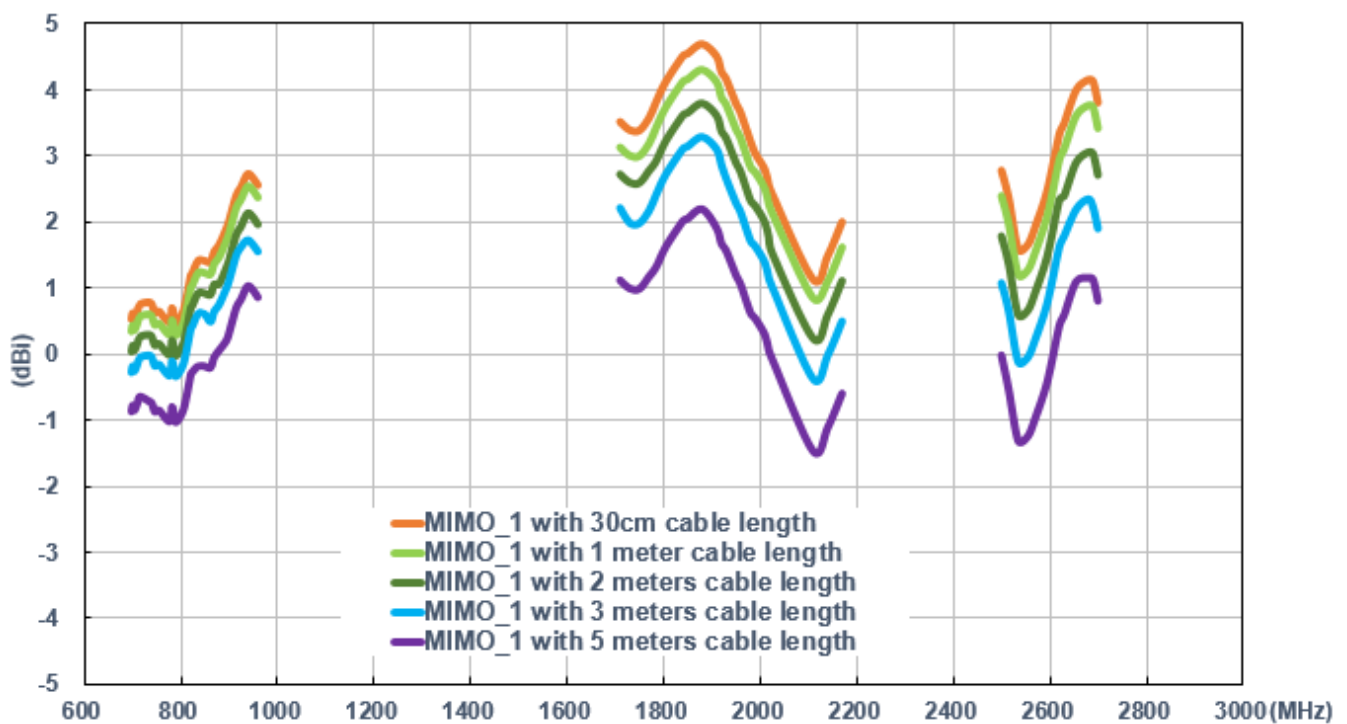

## 7.5 Return Loss – Free Space MIMO 2

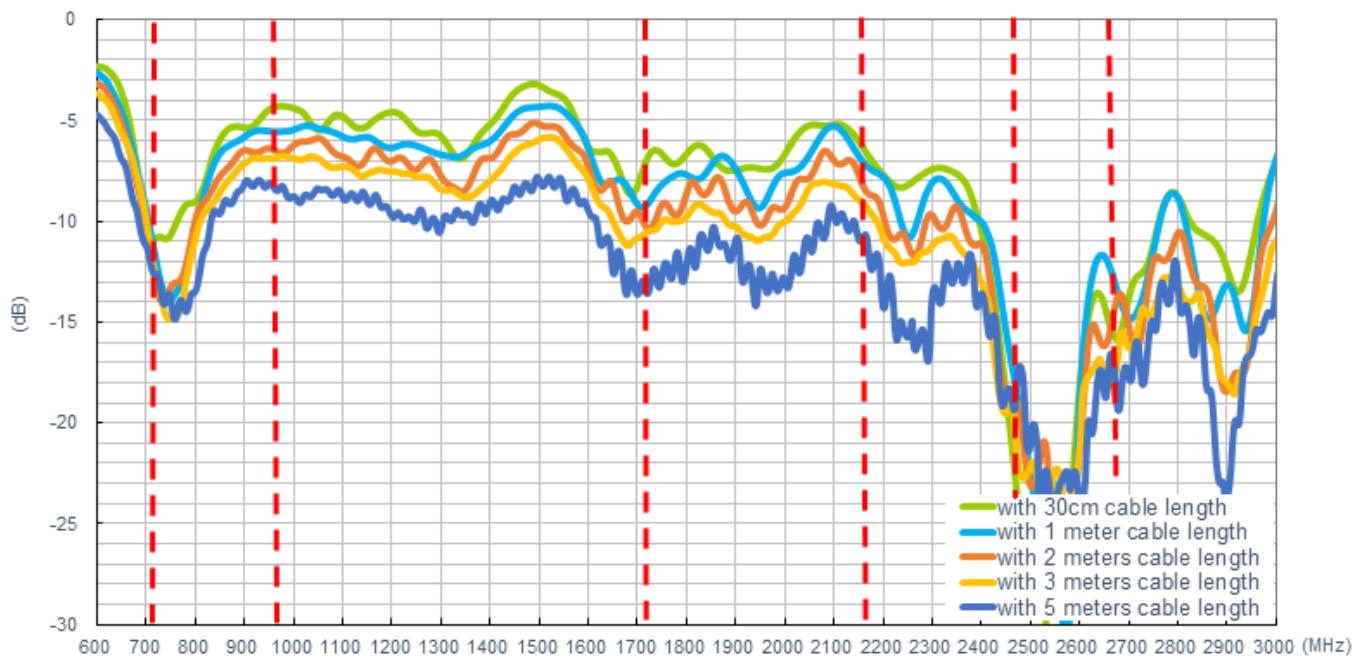

## 7.6 Efficiency – Free Space MIMO 2

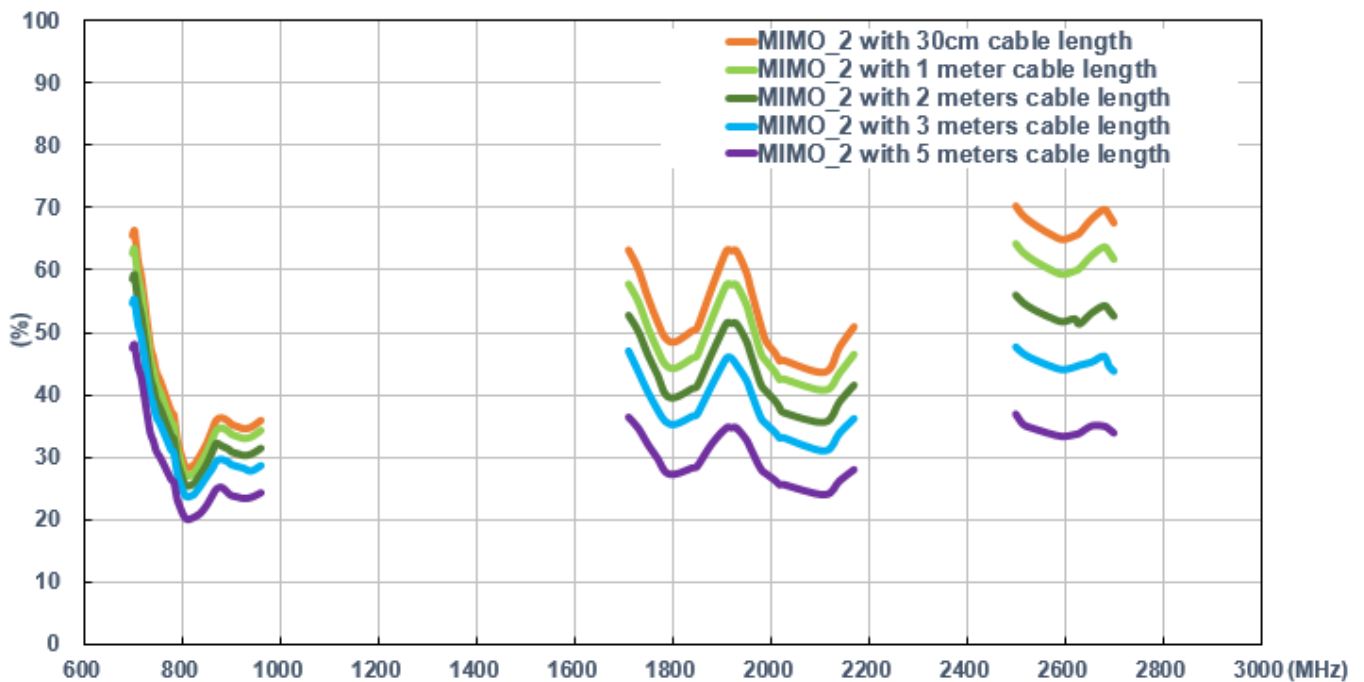

## 7.7 Average Gain – Free Space MIMO 2

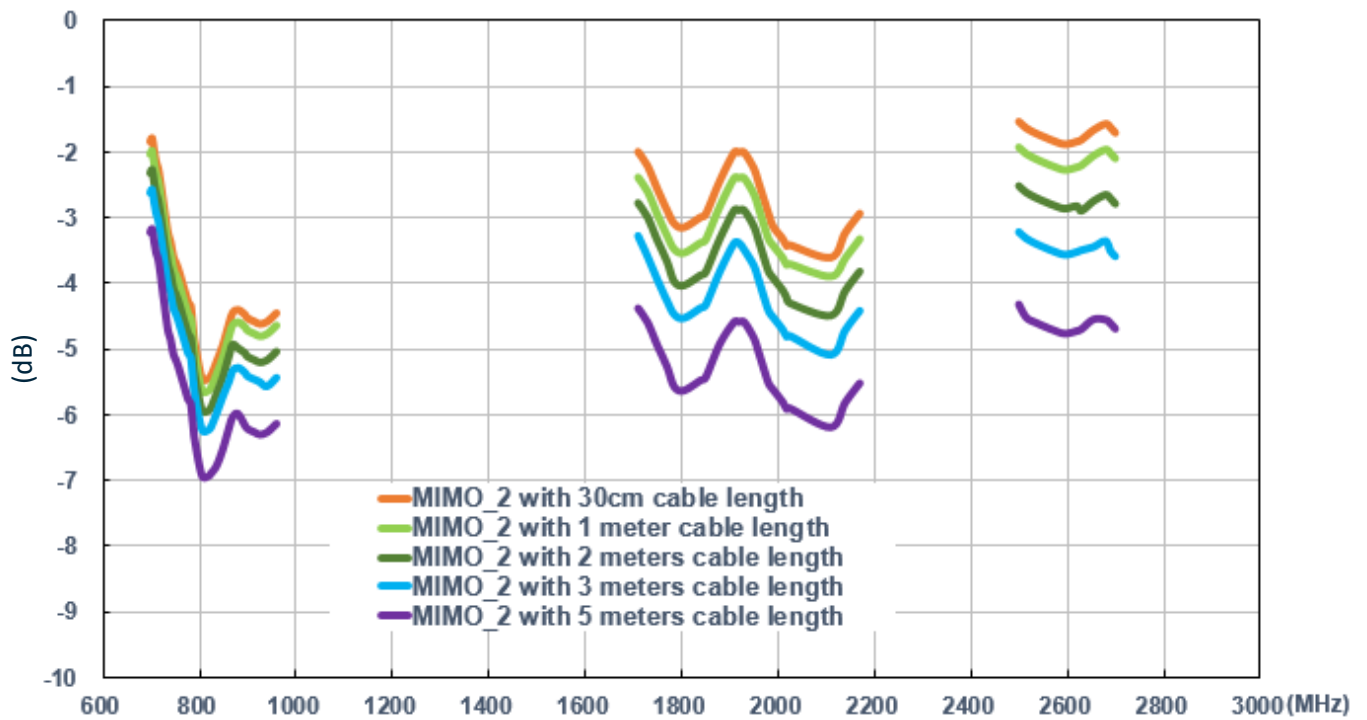

## 7.8 Peak Gain – Free Space MIMO 2

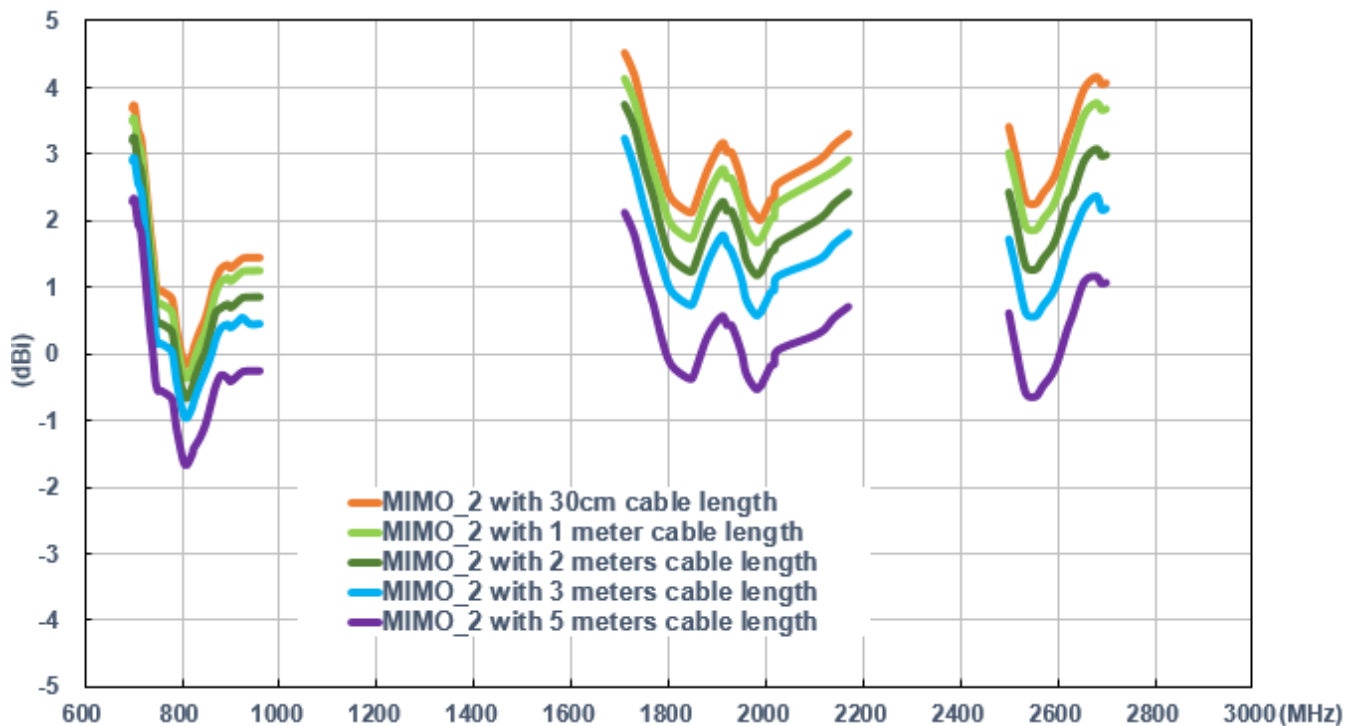

## 7.9 Isolation of MIMO 1 & 2

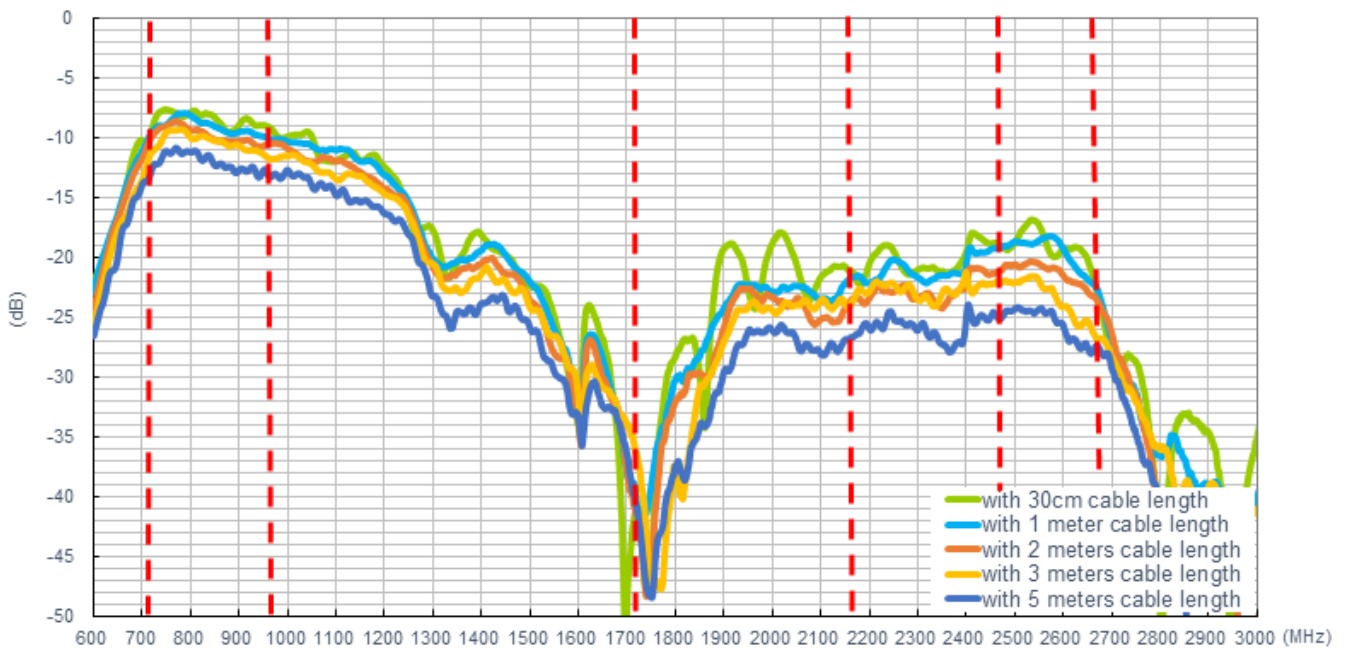

## 7.10 Return Loss – 2mm ABS MIMO 1

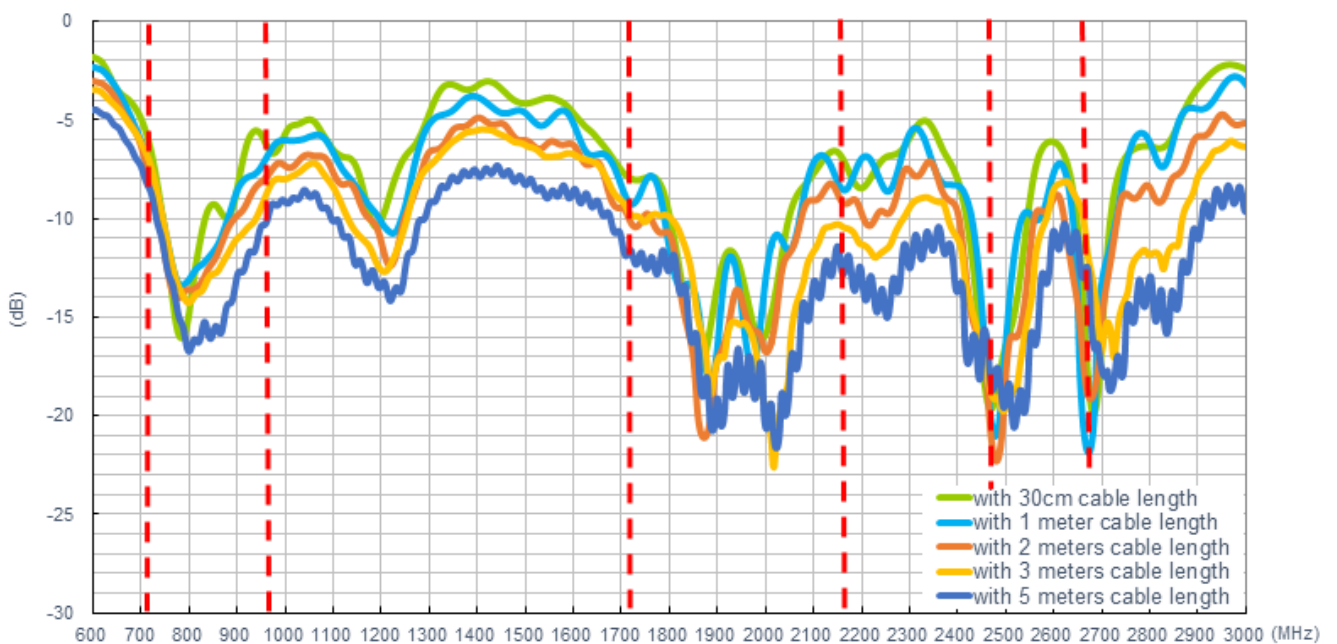

### 7.11 Efficiency – 2mm ABS MIMO 1

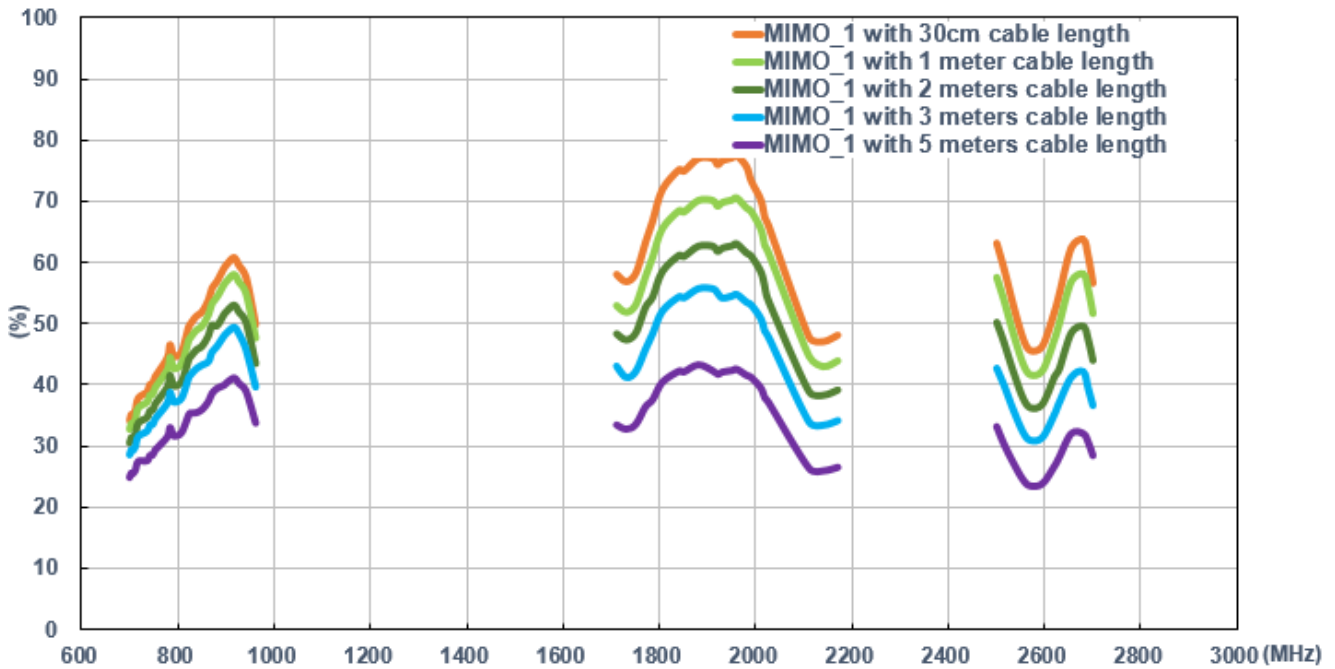

### 7.12 Average Gain – 2mm ABS MIMO 1

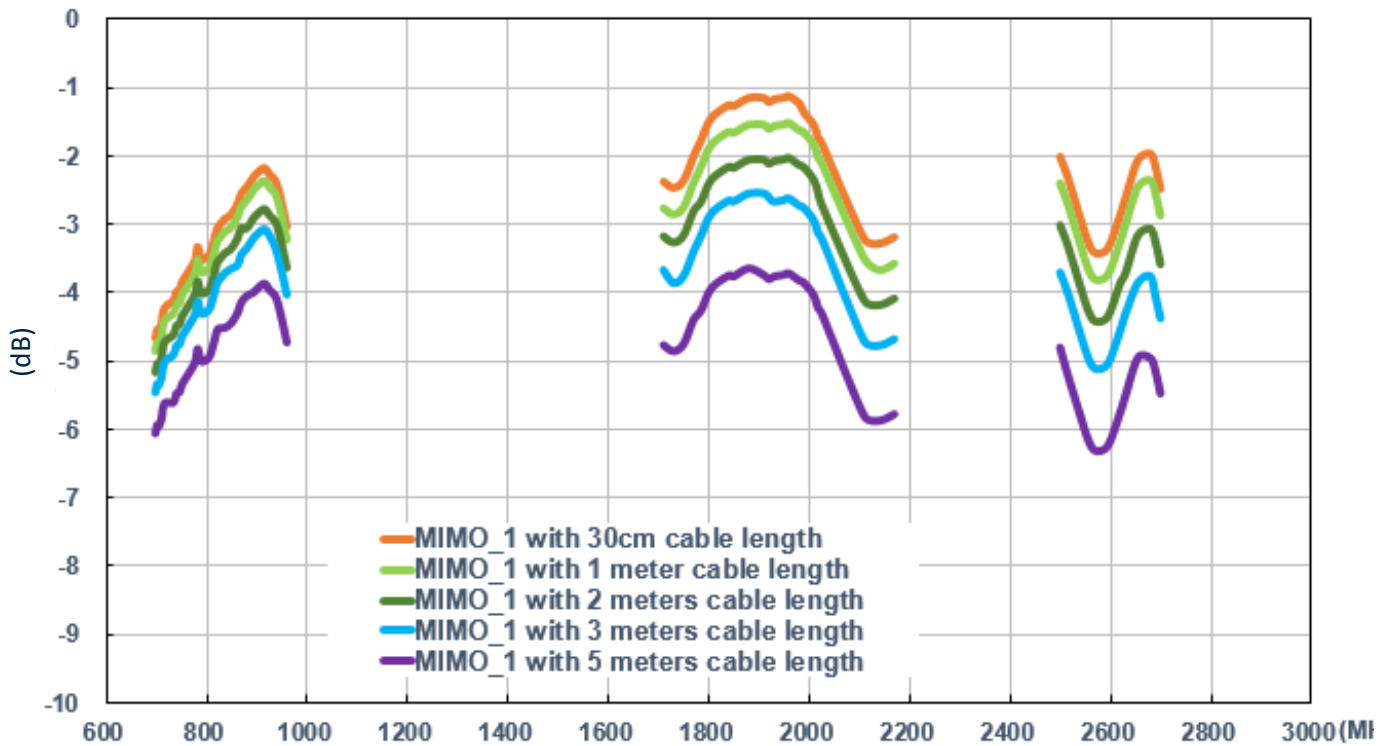



### 7.13 Peak Gain – 2mm ABS MIMO 1

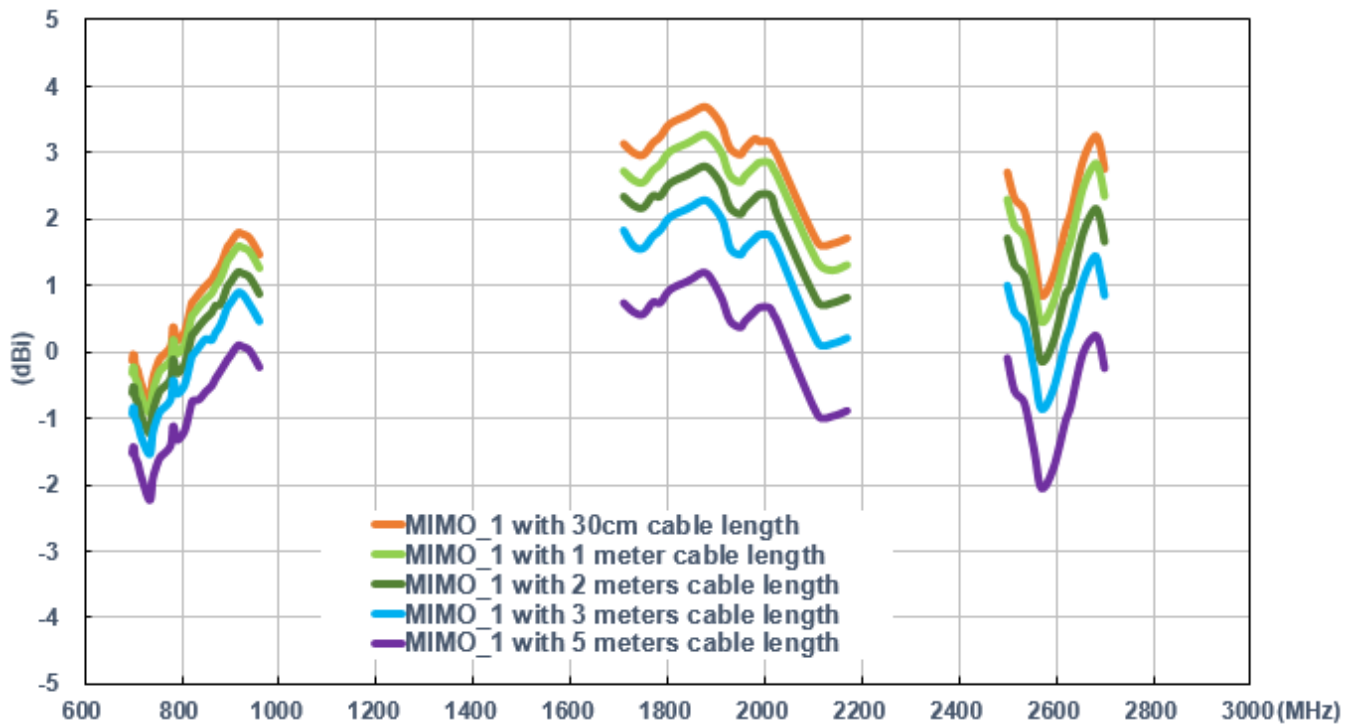

### 7.14 Return Loss – 2mm ABS MIMO 2

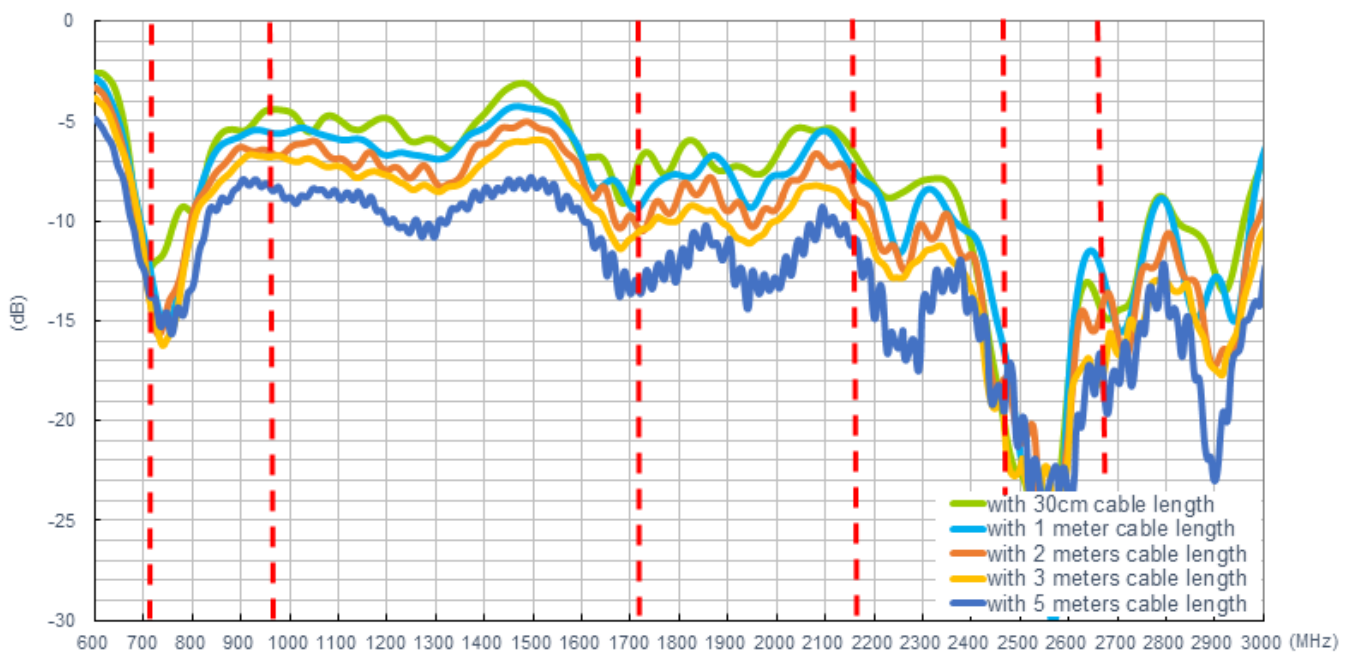

### 7.15 Efficiency – 2mm ABS MIMO 2

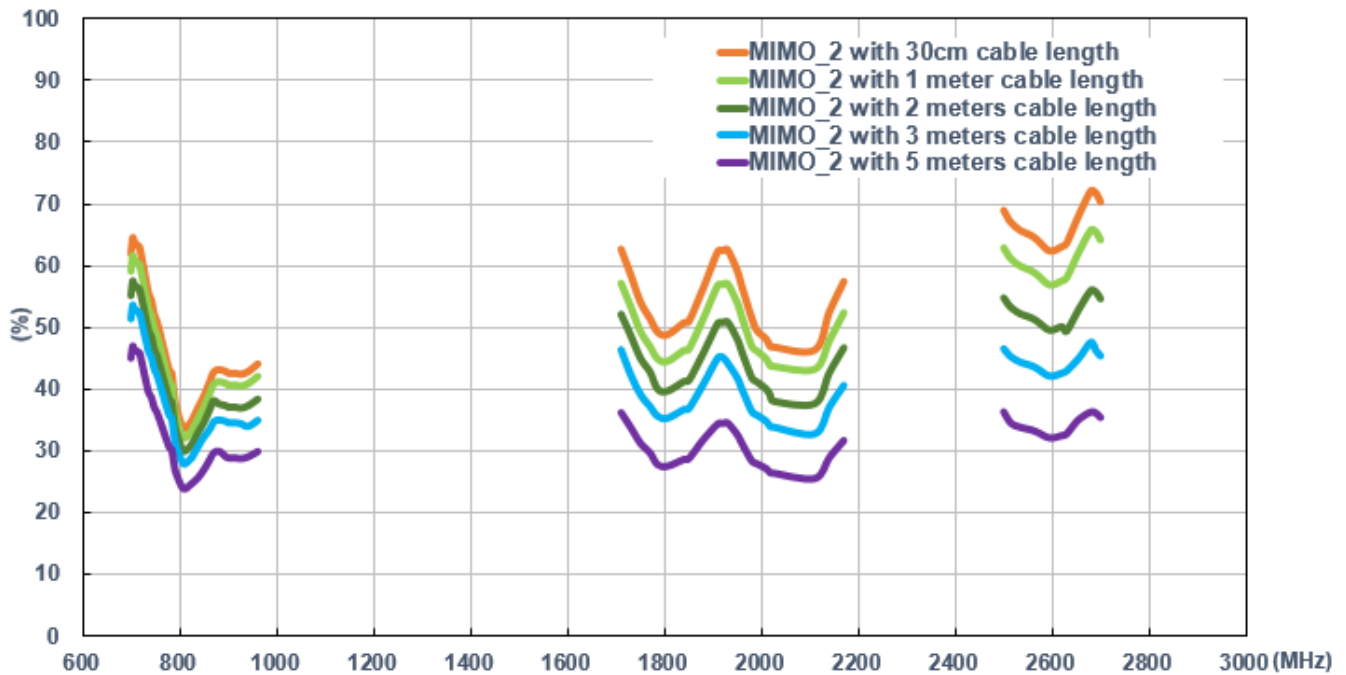

### 7.16 Average Gain – 2mm ABS MIMO 2

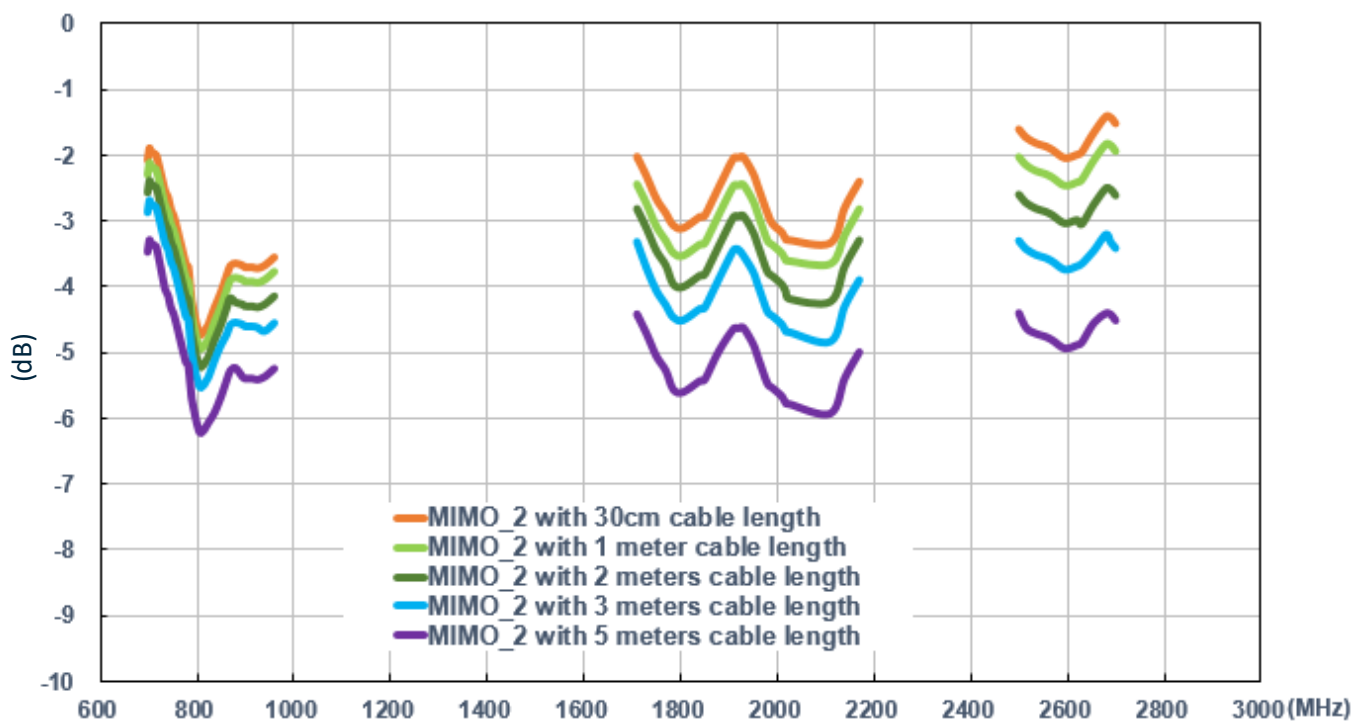

### 7.17 Peak Gain – 2mm ABS MIMO 2

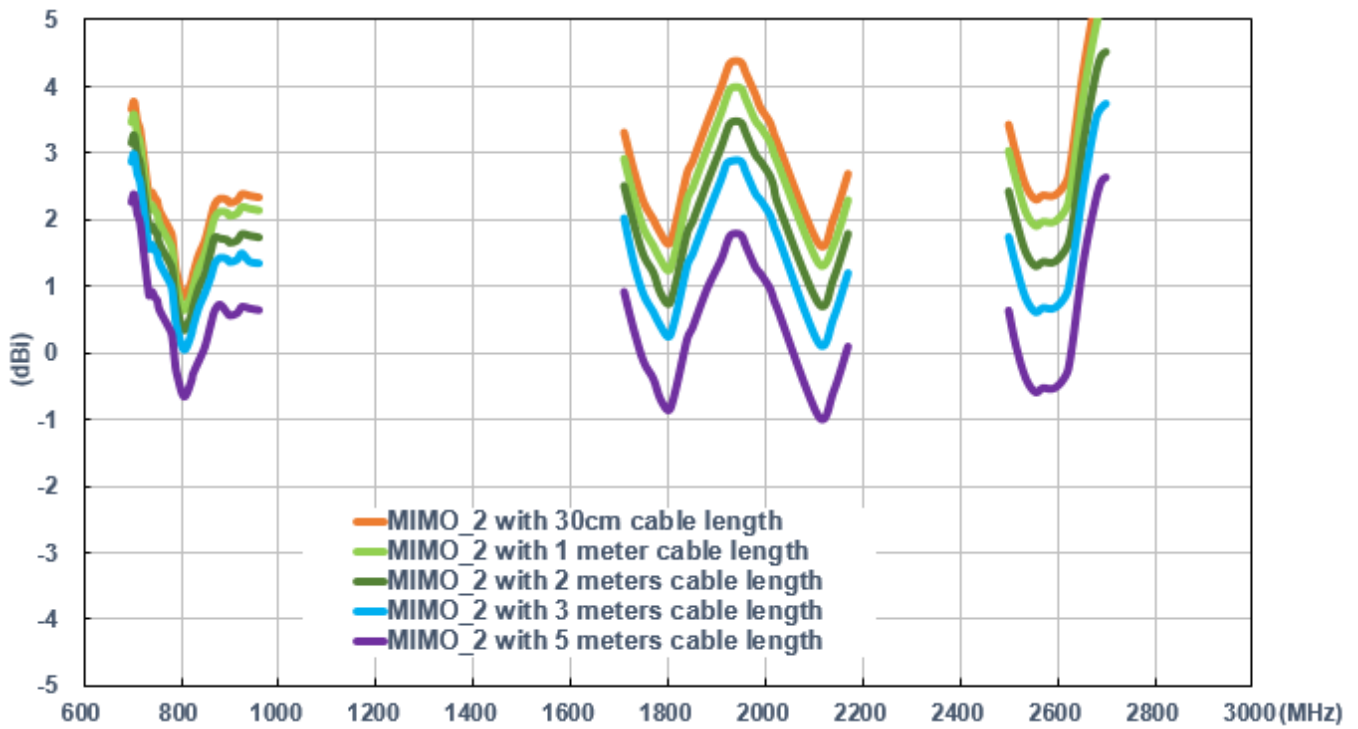

### 7.18 Isolation of MIMO 1 & 2 - 2mm ABS

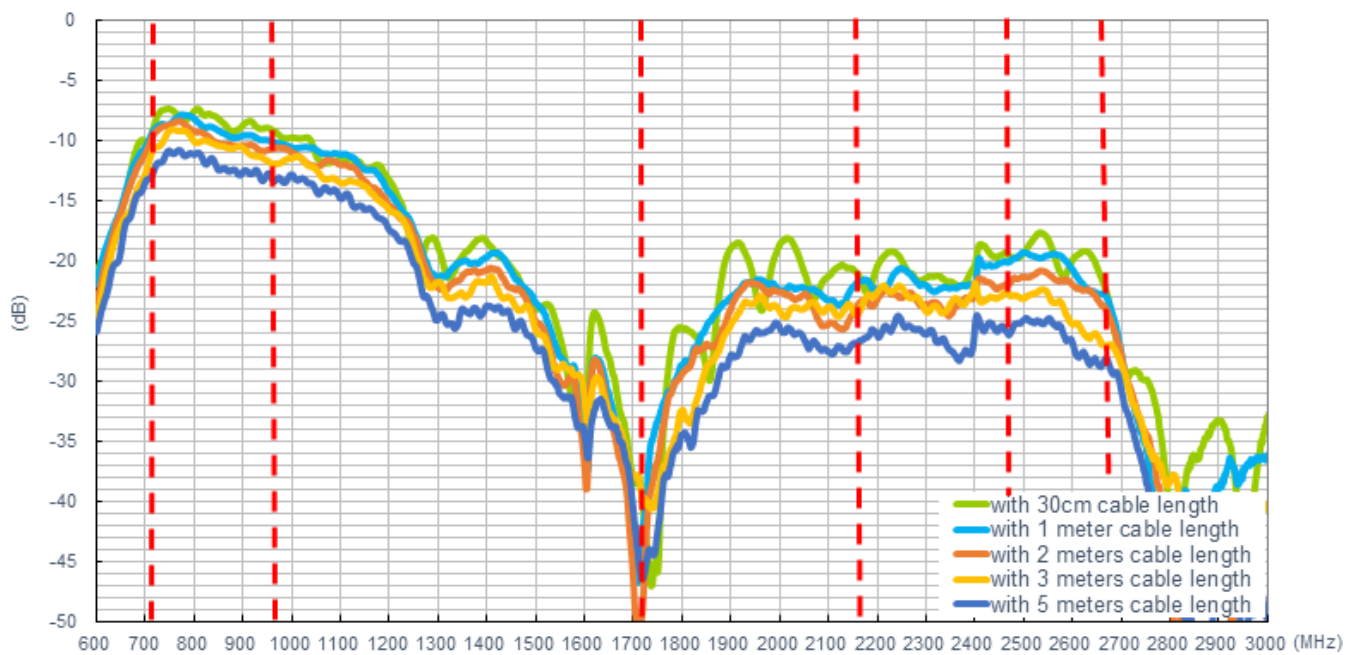

## 7.19 Return Loss – On Glass MIMO 1

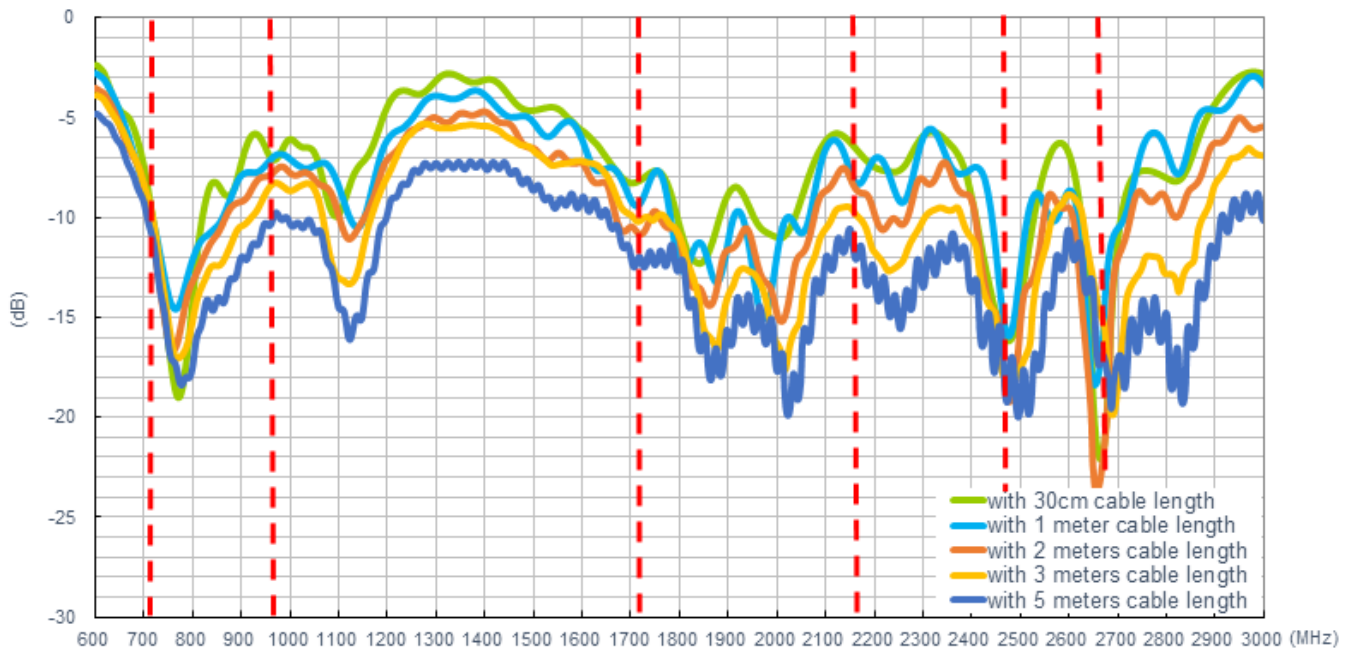

## 7.20 Efficiency – On Glass MIMO 1

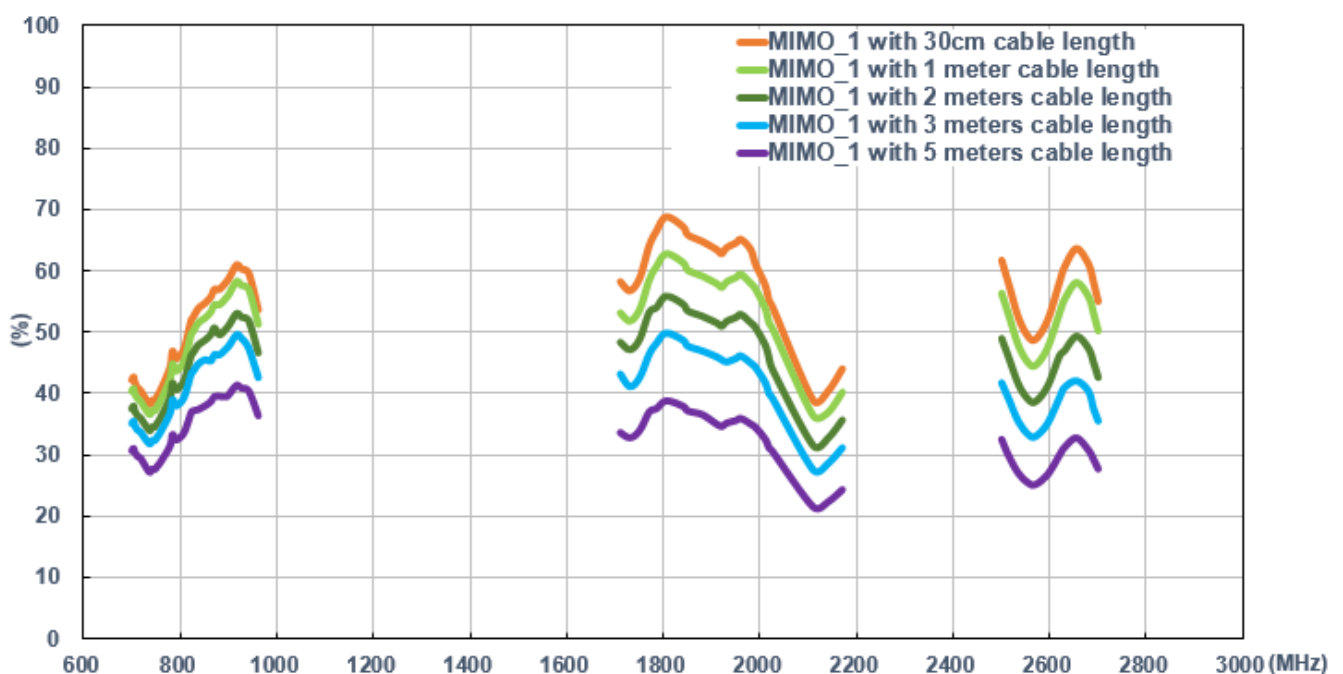

### 7.21 Average Gain – On Glass MIMO 1

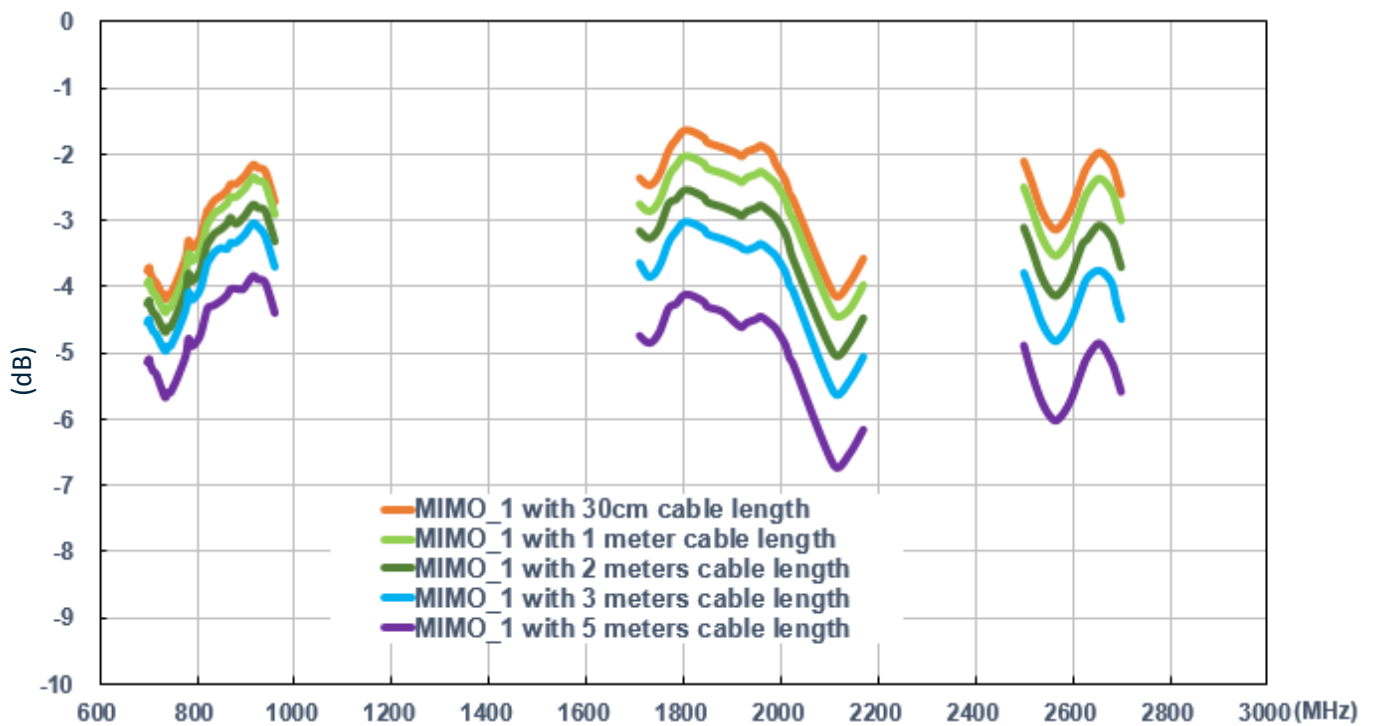

### 7.22 Peak Gain – On Glass MIMO 1

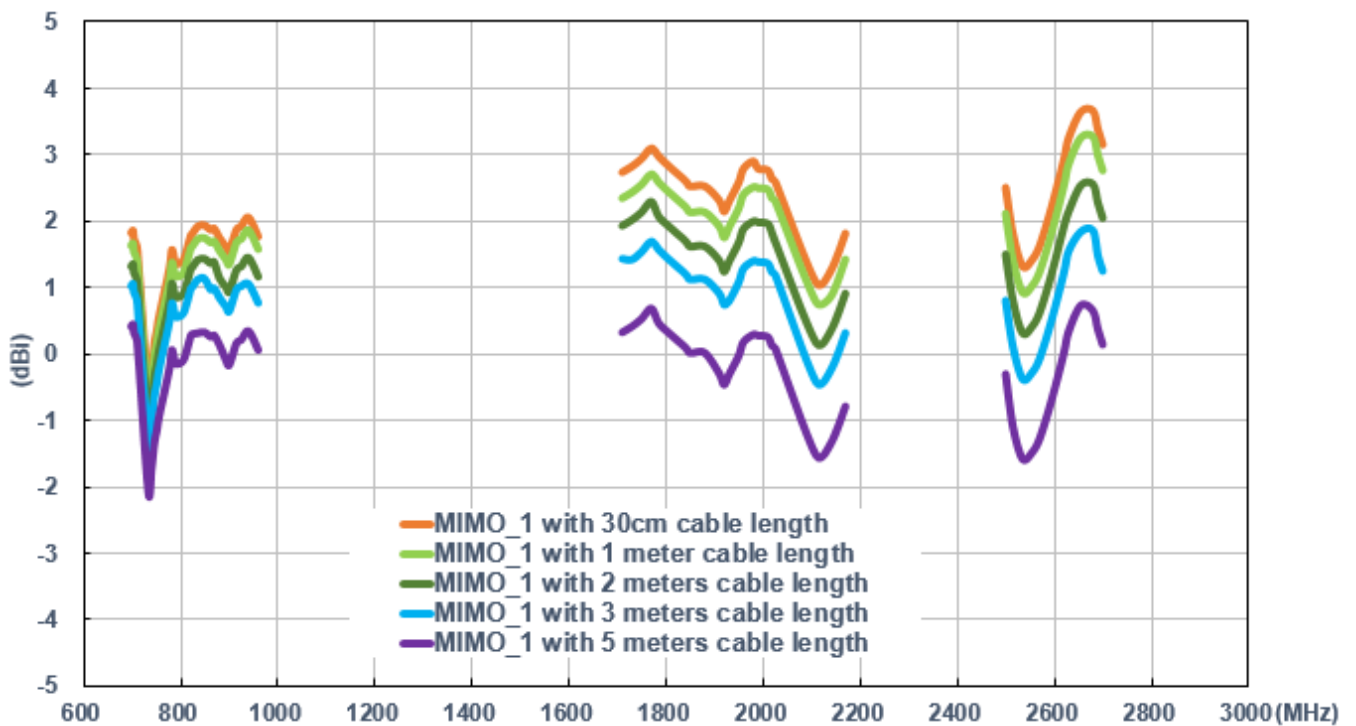

### 7.23 Return Loss – On Glass MIMO 2

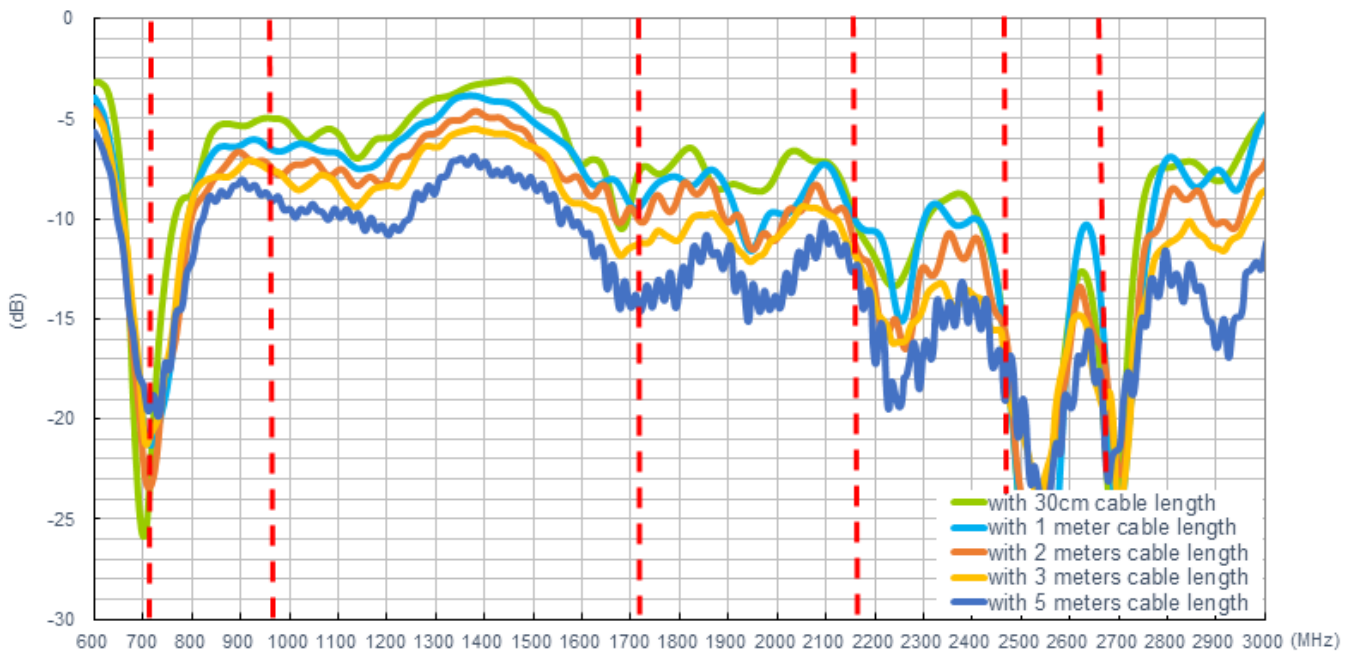

### 7.24 Efficiency – On Glass MIMO 2

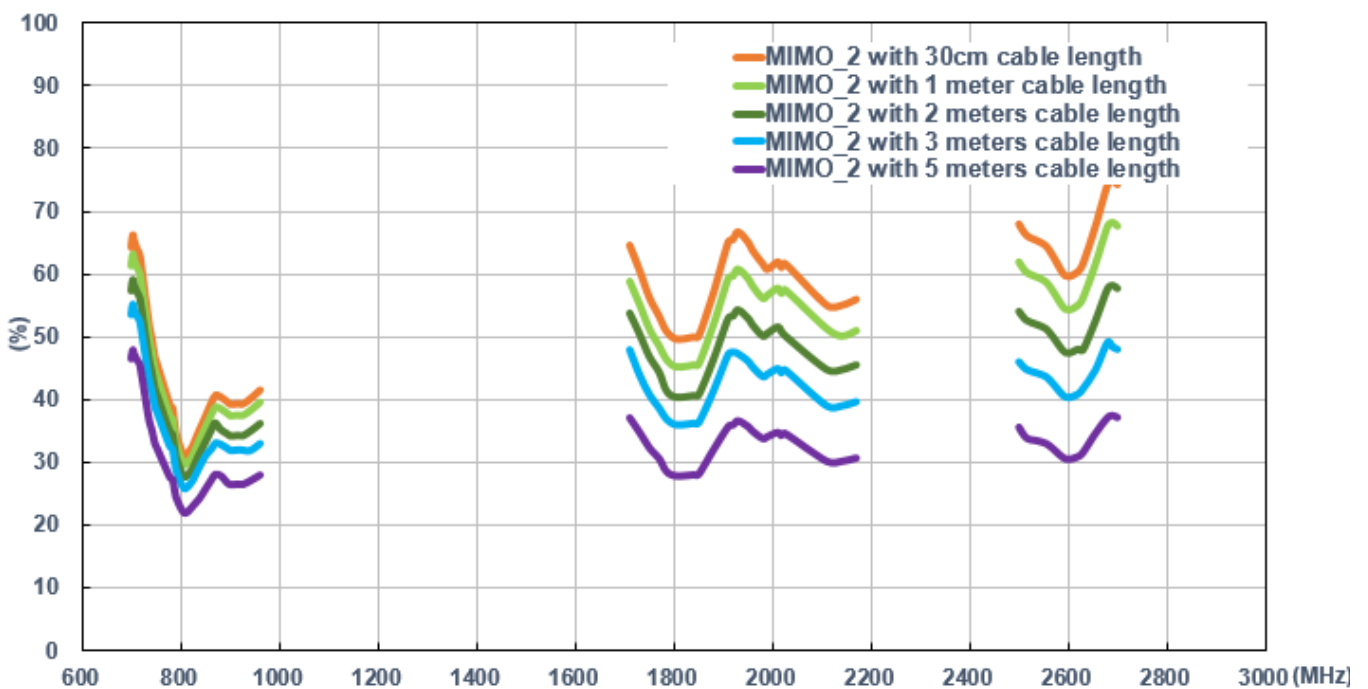

### 7.25 Average Gain – On Glass MIMO 2

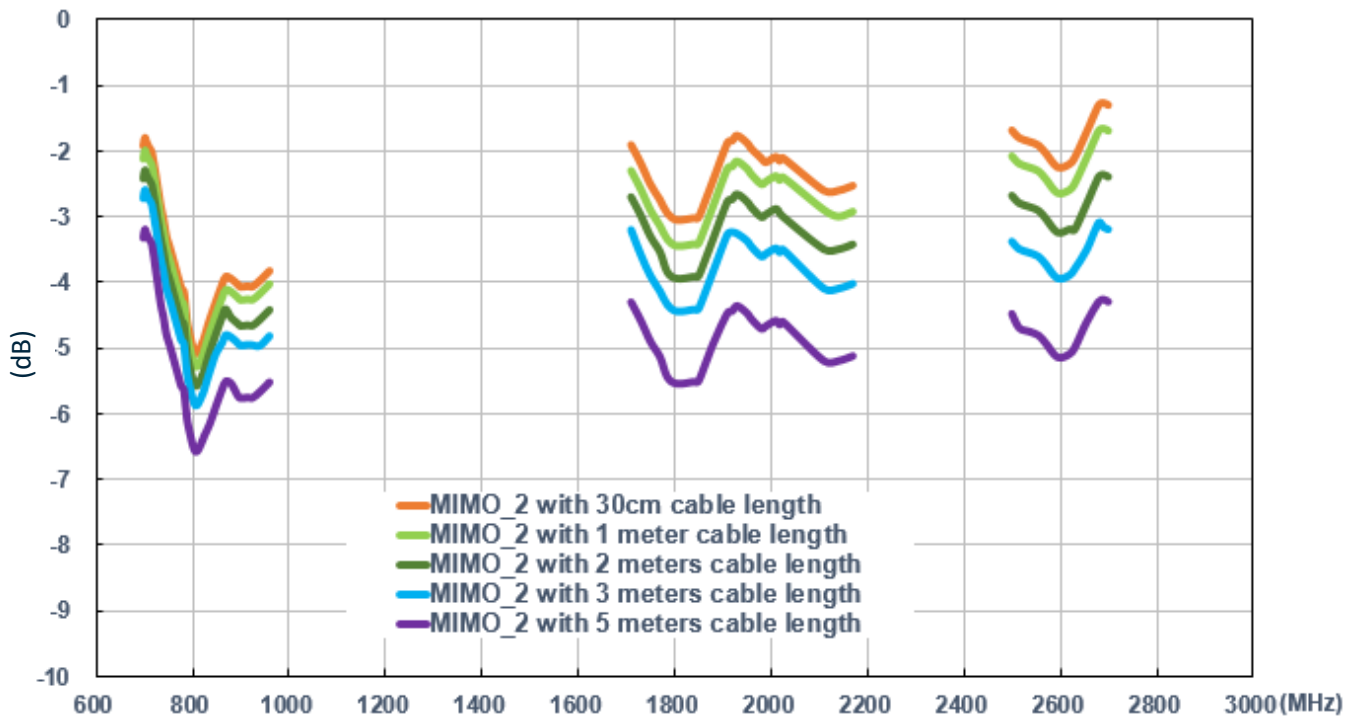

### 7.26 Peak Gain – On Glass MIMO 2

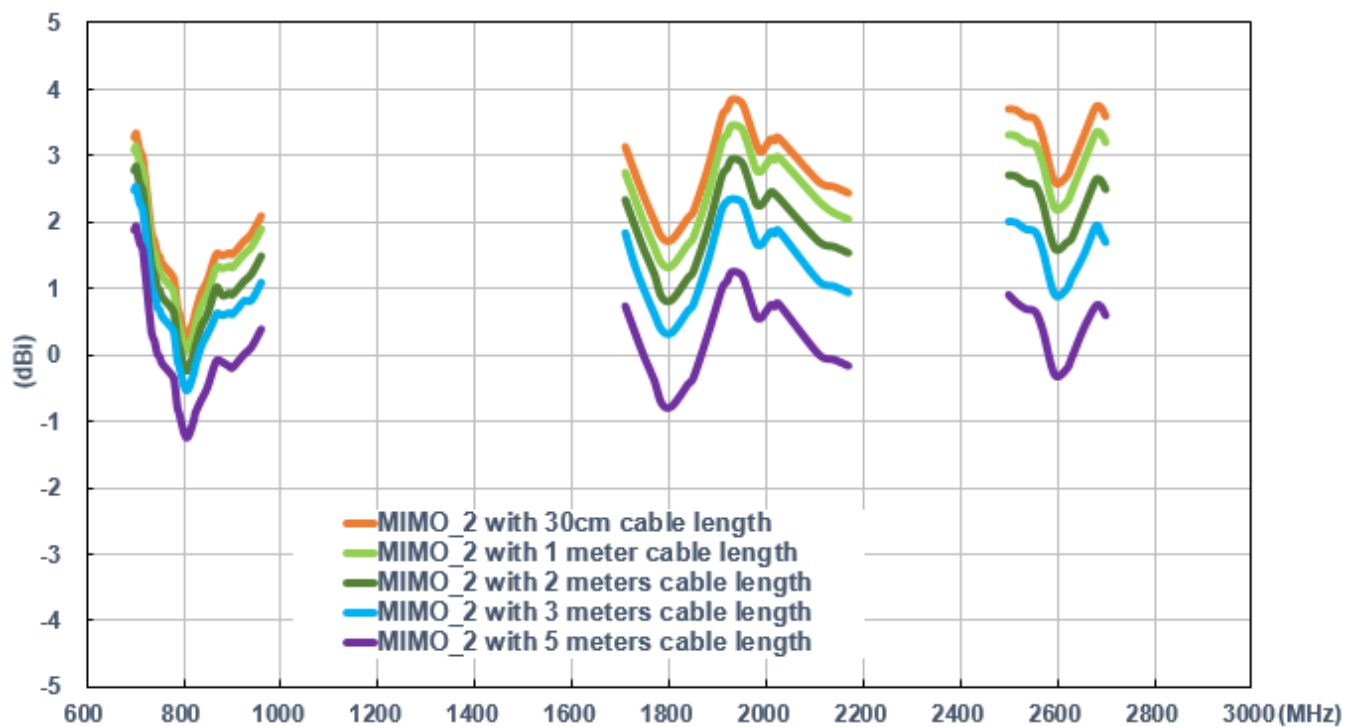

7.27 Isolation of MIMO 1 & 2 - On Glass

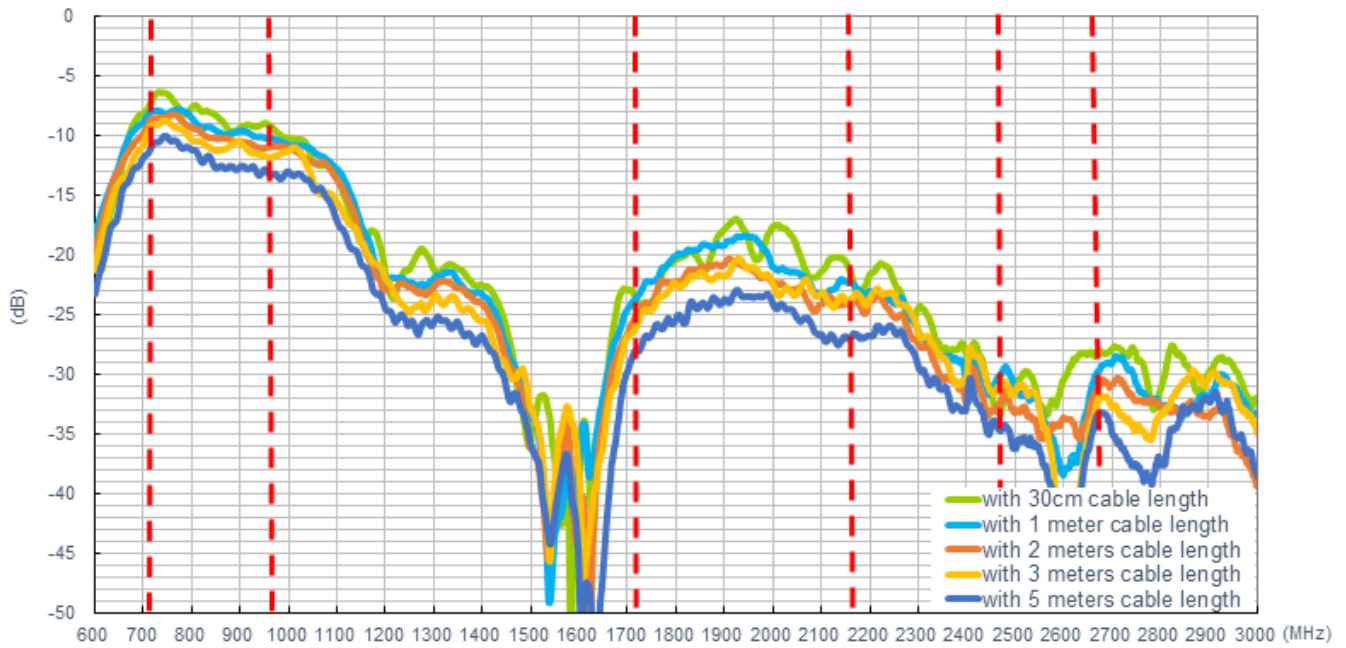







**TAOGLAS**®

[www.taoglas.com](http://www.taoglas.com)



Компания «Океан Электроники» предлагает заключение долгосрочных отношений при поставках импортных электронных компонентов на взаимовыгодных условиях!

Наши преимущества:

- Поставка оригинальных импортных электронных компонентов напрямую с производств Америки, Европы и Азии, а так же с крупнейших складов мира;
- Широкая линейка поставок активных и пассивных импортных электронных компонентов (более 30 млн. наименований);
- Поставка сложных, дефицитных, либо снятых с производства позиций;
- Оперативные сроки поставки под заказ (от 5 рабочих дней);
- Экспресс доставка в любую точку России;
- Помощь Конструкторского Отдела и консультации квалифицированных инженеров;
- Техническая поддержка проекта, помощь в подборе аналогов, поставка прототипов;
- Поставка электронных компонентов под контролем ВП;
- Система менеджмента качества сертифицирована по Международному стандарту ISO 9001;
- При необходимости вся продукция военного и аэрокосмического назначения проходит испытания и сертификацию в лаборатории (по согласованию с заказчиком);
- Поставка специализированных компонентов военного и аэрокосмического уровня качества (Xilinx, Altera, Analog Devices, Intersil, Interpoint, Microsemi, Actel, Aeroflex, Peregrine, VPT, Syfer, Eurofarad, Texas Instruments, MS Kennedy, Miteq, Cobham, E2V, MA-COM, Hittite, Mini-Circuits, General Dynamics и др.);

Компания «Океан Электроники» является официальным дистрибьютором и эксклюзивным представителем в России одного из крупнейших производителей разъемов военного и аэрокосмического назначения «JONHON», а так же официальным дистрибьютором и эксклюзивным представителем в России производителя высокотехнологичных и надежных решений для передачи СВЧ сигналов «FORSTAR».



## JONHON

«JONHON» (основан в 1970 г.)

Разъемы специального, военного и аэрокосмического назначения:

(Применяются в военной, авиационной, аэрокосмической, морской, железнодорожной, горно- и нефтедобывающей отраслях промышленности)

«FORSTAR» (основан в 1998 г.)

ВЧ соединители, коаксиальные кабели, кабельные сборки и микроволновые компоненты:

(Применяются в телекоммуникациях гражданского и специального назначения, в средствах связи, РЛС, а так же военной, авиационной и аэрокосмической отраслях промышленности).



Телефон: 8 (812) 309-75-97 (многоканальный)

Факс: 8 (812) 320-03-32

Электронная почта: [ocean@oceanchips.ru](mailto:ocean@oceanchips.ru)

Web: <http://oceanchips.ru/>

Адрес: 198099, г. Санкт-Петербург, ул. Калинина, д. 2, корп. 4, лит. А