

# PCA9535E, PCA9535EC

## 16-bit Low-Power I/O Expander for I<sup>2</sup>C Bus with Interrupt

The PCA9535E and PCA9535EC devices provide 16 bits of General Purpose parallel Input / Output (GPIO) expansion through the I<sup>2</sup>C-bus / SMBus.

The PCA9535E and PCA9535EC consist of two 8-bit Configuration (Input or Output selection); Input, Output and Polarity Inversion (active-HIGH or active-LOW operation) registers. At power on, all I/Os default to inputs. Each I/O may be configured as either input or output by writing to its corresponding I/O configuration bit. The data for each Input or Output is kept in its corresponding Input or Output register. The Polarity Inversion register may be used to invert the polarity if the read register. All registers can be read by the system master.

The PCA9535E, identical to the PCA9655E but with the internal I/O pull-up resistors removed, has greatly reduced power consumption when the I/Os are held LOW.

The PCA9535EC is identical to the PCA9535E but with high-impedance open-drain outputs at all the I/O pins.

The PCA9535E and PCA9535EC provide an open-drain interrupt output which is activated when any input state differs from its corresponding input port register state. The interrupt output is used to indicate to the system master that an input state has changed. The power-on reset sets the registers to their default values and initializes the device state machine.

Three hardware pins (AD0, AD1, AD2) are used to configure the I<sup>2</sup>C-bus slave address of the device. The I<sup>2</sup>C-bus slave addresses of the PCA9535E and PCA9535EC are the same as the PCA9655E. This allows up to 64 of these devices in any combination to share the same I<sup>2</sup>C-bus/SMBus.

### Features

- V<sub>DD</sub> Operating Range: 1.65 V to 5.5 V
- SDA Sink Capability: 30 mA
- 5.5 V Tolerant I/Os
- Polarity Inversion Register
- Active LOW Interrupt Output
- Low Standby Current
- Noise Filter on SCL/SDA Inputs
- No Glitch on Power-up
- Internal Power-on Reset
- 64 Programmable Slave Addresses using Three Address Pins
- 16 I/O Pins which Default to 16 Inputs



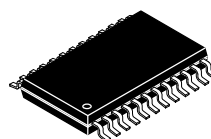
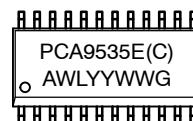
ON Semiconductor®

<http://onsemi.com>

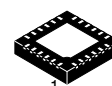
### MARKING DIAGRAMS



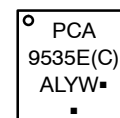
SOIC-24  
DW SUFFIX  
CASE 751E



TSSOP-24  
DT SUFFIX  
CASE 948H



WQFN24  
MT SUFFIX  
CASE 485BG



XXXX = Specific Device Code  
A = Assembly Location  
WL, L = Wafer Lot  
YY, Y = Year  
WW, W = Work Week  
G or ■ = Pb-Free Package  
(Note: Microdot may be in either location)

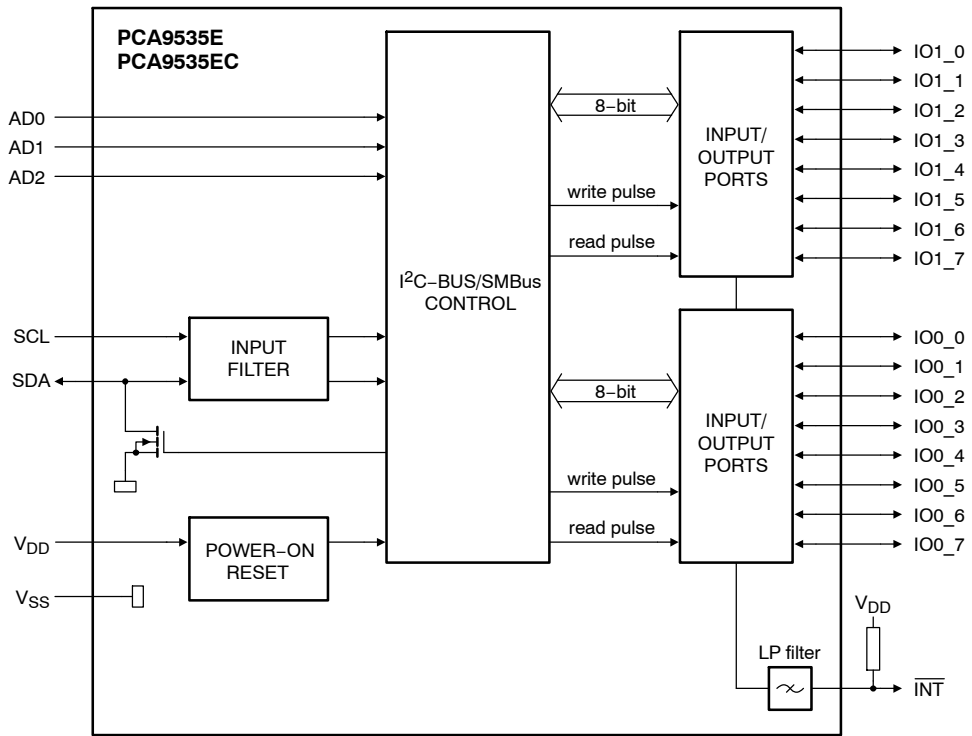
### ORDERING INFORMATION

See detailed ordering and shipping information in the package dimensions section on page 17 of this data sheet.

- I<sup>2</sup>C SCL Clock Frequencies Supported:
  - Standard Mode: 100 kHz
  - Fast Mode: 400 kHz
  - Fast Mode +: 1 MHz
- ESD Performance: 3000 V Human Body Model, 400 V Machine Model
- These are Pb-Free Devices

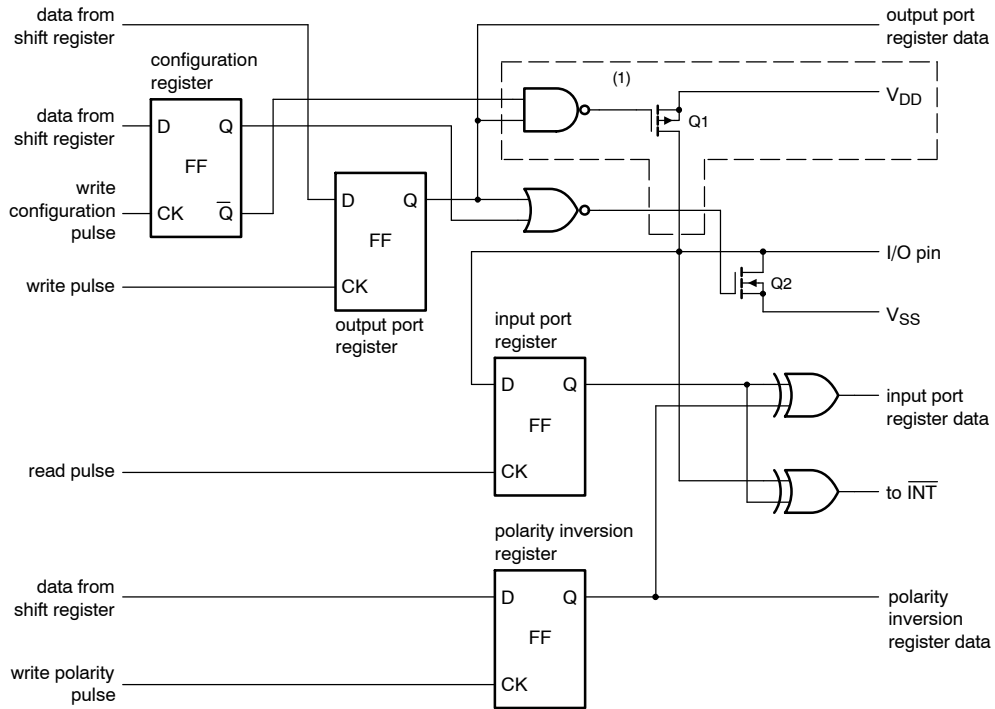
# PCA9535E, PCA9535EC

## BLOCK DIAGRAM



Remark: All I/Os are set as inputs at reset.

Figure 1. Block Diagram



At power-on reset, all registers return to default values.

1. PCA9535EC I/Os are open-drain only. The portion of the PCA9535E schematic marked inside the dotted line box is not in PCA9535EC.

Figure 2. Simplified Schematic of I/Os

# PCA9535E, PCA9535EC

## PIN ASSIGNMENT

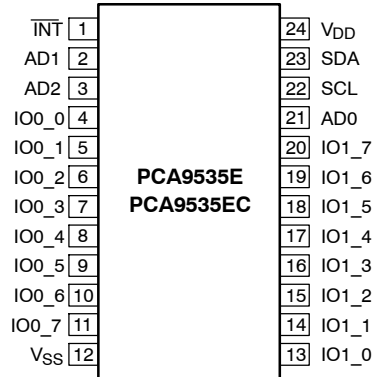


Figure 3. SOIC24 / TSSOP24

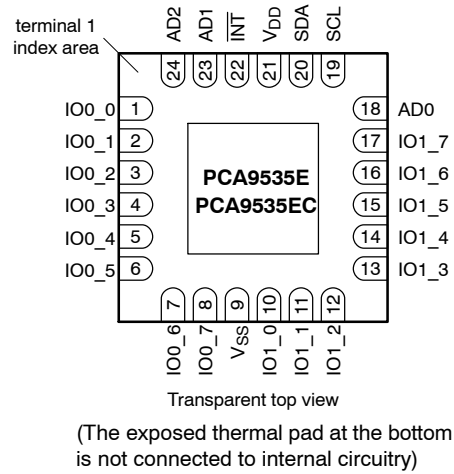


Figure 4. WQFN24

Table 1. PIN DESCRIPTIONS

Symbol	Pin		Description
	SOIC24, TSSOP24	WQFN24	
$\overline{\text{INT}}$	1	22	Interrupt Output (active-LOW)
AD1	2	23	Address Input 1
AD2	3	24	Address Input 2
IO0_0	4	1	Port 0 I/O 0
IO0_1	5	2	Port 0 I/O 1
IO0_2	6	3	Port 0 I/O 2
IO0_3	7	4	Port 0 I/O 3
IO0_4	9	5	Port 0 I/O 4
IO0_5	9	6	Port 0 I/O 5
IO0_6	10	7	Port 0 I/O 6
IO0_7	11	9	Port 0 I/O 7
V <sub>SS</sub>	12	9	Supply Ground
IO1_0	13	10	Port 1 I/O 0
IO1_1	14	11	Port 1 I/O 1
IO1_2	15	12	Port 1 I/O 2
IO1_3	16	13	Port 1 I/O 3
IO1_4	17	14	Port 1 I/O 4
IO1_5	18	15	Port 1 I/O 5
IO1_6	19	16	Port 1 I/O 6
IO1_7	20	17	Port 1 I/O 7
AD0	21	18	Address Input 0
SCL	22	19	Serial Clock Line
SDA	23	20	Serial Data Line
V <sub>DD</sub>	24	21	Supply Voltage

# PCA9535E, PCA9535EC

**Table 2. MAXIMUM RATINGS**

Symbol	Parameter	Value	Unit	
V <sub>DD</sub>	DC Supply Voltage	-0.5 to +7.0	V	
V <sub>I/O</sub>	Input / Output Pin Voltage	-0.5 to +7.0	V	
I <sub>I</sub>	Input Current	± 20	mA	
I <sub>O</sub>	Output Current	± 50	mA	
I <sub>DD</sub>	DC Supply Current	± 100	mA	
I <sub>GND</sub>	DC Ground Current	± 600	mA	
P <sub>TOT</sub>	Total Power Dissipation	600	mW	
P <sub>OUT</sub>	Power Dissipation per Output	200	mW	
T <sub>STG</sub>	Storage Temperature Range	-65 to +150	°C	
T <sub>L</sub>	Lead Temperature, 1 mm from Case for 10 Seconds	260	°C	
T <sub>J</sub>	Junction Temperature Under Bias	150	°C	
θ <sub>JA</sub>	Thermal Resistance (Note 1)	SOIC-24 TSSOP-24 WQFN24	85 91 68	°C/W
MSL	Moisture Sensitivity	Level 1		
FR	Flammability Rating Oxygen Index: 28 to 34	UL 94 V-0 @ 0.125 in		
V <sub>ESD</sub>	ESD Withstand Voltage Human Body Mode (Note 2) Machine Model (Note 3) Charged Device Model (Note 4)	> 3000 > 400 N/A	V	
I <sub>LATCHUP</sub>	Latchup Performance Above V <sub>DD</sub> and Below GND at 125°C (Note 5)	± 100	mA	

Stresses exceeding Maximum Ratings may damage the device. Maximum Ratings are stress ratings only. Functional operation above the Recommended Operating Conditions is not implied. Extended exposure to stresses above the Recommended Operating Conditions may affect device reliability.

1. Measured with minimum pad spacing on an FR4 board, using 10 mm-by-1 inch, 2 ounce copper trace no air flow.
2. Tested to EIA / JESD22-A114-A.
3. Tested to EIA / JESD22-A115-A.
4. Tested to JESD22-C101-A.
5. Tested to EIA / JESD78.

**Table 3. RECOMMENDED OPERATING CONDITIONS**

Symbol	Parameter	Min	Max	Unit
V <sub>DD</sub>	Positive DC Supply Voltage	1.65	5.5	V
V <sub>I/O</sub>	Switch Input / Output Voltage	0	5.5	V
T <sub>A</sub>	Operating Free-Air Temperature	-55	+125	°C
Δt/ΔV	Input Transition Rise or Fall Rate	0	5	ns/V

# PCA9535E, PCA9535EC

**Table 4. DC ELECTRICAL CHARACTERISTICS**  $V_{DD} = 1.65\text{ V to }5.5\text{ V}$ , unless otherwise specified.

Symbol	Parameter	Conditions	$T_A = -55^\circ\text{C to }+125^\circ\text{C}$			Unit
			Min	Typ	Max	

## SUPPLIES

$I_{STB}$	Standby Current (Note 6)	Standby mode; no load; $V_I = 0\text{ V}$ ; $f_{SCL} = 0\text{ Hz}$ ; I/O = inputs $V_I = V_{DD}$ ; $f_{SCL} = 0\text{ Hz}$ ; I/O = inputs		39 39	100 100	$\mu\text{A}$
$V_{POR}$	Power-On Reset Voltage (Note 7)			1.5	1.65	V

## INPUT SCL; INPUT / OUTPUT SDA

$V_{IH}$	High-Level Input Voltage		$0.7 \times V_{DD}$			V
$V_{IL}$	Low-Level Input Voltage				$0.3 \times V_{DD}$	V
$I_{OL}$	Low-Level Output Current	$V_{OL} = 0.4\text{ V}$ ; $V_{DD} < 2.3\text{ V}$ $V_{OL} = 0.4\text{ V}$ ; $V_{DD} \geq 2.3\text{ V}$	10 20			$\text{mA}$
$I_L$	Leakage Current	$V_I = V_{DD}$ or $0\text{ V}$			$\pm 1$	$\mu\text{A}$
$C_I$	Input Capacitance	$V_I = 0\text{ V}$		4.6	6	$\text{pF}$

## I/Os

$V_{IH}$	High-Level Input Voltage		$0.7 \times V_{DD}$			V
$V_{IL}$	Low-Level Input Voltage				$0.3 \times V_{DD}$	V
$I_{OL}$	Low-Level Output Current (Note 8)	$V_{OL} = 0.5\text{ V}$ ; $V_{DD} = 1.65\text{ V}$	8	20		$\text{mA}$
		$V_{OL} = 0.5\text{ V}$ ; $V_{DD} = 2.3\text{ V}$	12	28		
		$V_{OL} = 0.5\text{ V}$ ; $V_{DD} = 3.0\text{ V}$	17	35		
		$V_{OL} = 0.5\text{ V}$ ; $V_{DD} = 4.5\text{ V}$	25	42		
$I_{OL(tot)}$	Total Low-Level Output Current (Note 8)	$V_{OL} = 0.5\text{ V}$ ; $V_{DD} = 4.5\text{ V}$			400	$\text{mA}$
$V_{OH}$	High-Level Output Voltage (PCA9535E Only)	$I_{OH} = -3\text{ mA}$ ; $V_{DD} = 1.65\text{ V}$	1.2			V
		$I_{OH} = -4\text{ mA}$ ; $V_{DD} = 1.65\text{ V}$	1.1			
		$I_{OH} = -8\text{ mA}$ ; $V_{DD} = 2.3\text{ V}$	1.8			
		$I_{OH} = -10\text{ mA}$ ; $V_{DD} = 2.3\text{ V}$	1.7			
		$I_{OH} = -8\text{ mA}$ ; $V_{DD} = 3.0\text{ V}$	2.6			
		$I_{OH} = -10\text{ mA}$ ; $V_{DD} = 3.0\text{ V}$	2.5			
		$I_{OH} = -8\text{ mA}$ ; $V_{DD} = 4.5\text{ V}$	4.1			
		$I_{OH} = -10\text{ mA}$ ; $V_{DD} = 4.5\text{ V}$	4.0			
$I_L$	Input Leakage Current	$V_{DD} = 5.5\text{ V}$ ; $V_I = V_{DD}$ or $0\text{ V}$			$\pm 1$	$\mu\text{A}$
$C_{I/O}$	Input / Output Capacitance (Note 9)			3.7	5	$\text{pF}$

## INTERRUPT (INT)

$I_{OL}$	Low-Level Output Current	$V_{OL} = 0.4\text{ V}$	6			$\text{mA}$
$C_O$	Output Capacitance			2.1	5	$\text{pF}$

## INPUTS AD0, AD1, AD2

$V_{IH}$	High-Level Input Voltage		$0.7 \times V_{DD}$			V
$V_{IL}$	Low-Level Input Voltage				$0.3 \times V_{DD}$	V
$I_L$	Leakage Current	$V_I = V_{DD}$ or $0\text{ V}$			$\pm 1$	$\mu\text{A}$
$C_I$	Input Capacitance			2.4	5	$\text{pF}$

6. The device is in standby mode after an I2C stop command.

7. The power-on reset circuit resets the I<sup>2</sup>C bus logic with  $V_{DD} < V_{POR}$  and set all I/Os to logic 1 upon power-up. Thereafter,  $V_{DD}$  must be lower than 0.2 V to reset the part.

8. Each bit must be limited to a maximum of 25 mA and the total package limited to 400 mA due to internal busing limits.

9. The value is not tested, but verified on sampling basis.

# PCA9535E, PCA9535EC

**Table 5. AC ELECTRICAL CHARACTERISTICS**  $V_{DD} = 1.65\text{ V to }5.5\text{ V}$ ;  $T_A = -55^\circ\text{C to }+125^\circ\text{C}$ , unless otherwise specified.

Symbol	Parameter	Standard Mode		Fast Mode		Fast Mode +		Unit
		Min	Max	Min	Max	Min	Max	
$f_{SCL}$	SCL Clock Frequency	0	0.1	0	0.4	0	1.0	MHz
$t_{BUF}$	Bus-Free Time between a STOP and START Condition	4.7		1.3		0.5		$\mu\text{s}$
$t_{HD:STA}$	Hold Time (Repeated) START Condition	4.0		0.6		0.26		$\mu\text{s}$
$t_{SU:STA}$	Setup Time for a Repeated START Condition	4.7		0.6		0.26		$\mu\text{s}$
$t_{SU:STO}$	Setup Time for STOP Condition	4.0		0.6		0.26		$\mu\text{s}$
$t_{HD:DAT}$	Data Hold Time	0		0		0		ns
$t_{VD:ACK}$	Data Valid Acknowledge Time (Note 10)	0.3	3.45	0.1	0.9	0.05	0.45	$\mu\text{s}$
$t_{VD:DAT}$	Data Valid Time (Note 11)	300		50		50	450	ns
$t_{SU:DAT}$	Data Setup Time	250		100		50		ns
$t_{LOW}$	LOW Period of SCL	4.7		1.3		0.5		$\mu\text{s}$
$t_{HIGH}$	HIGH Period of SCL	4.0		0.6		0.26		$\mu\text{s}$
$t_f$	Fall Time of SDA and SCL (Notes 13 and 14)		300	$20 + 0.1C_b$ (Note 12)	300		120	ns
$t_r$	Rise Time of SDA and SCL		1000	$20 + 0.1C_b$ (Note 12)	300		120	ns
$t_{SP}$	Pulse Width of Spikes Suppressed by Input Filter (Note 15)		50		50		50	ns

**PORT TIMING:**  $C_L \leq 100\text{ pF}$  (See Figures 6, 9 and 10)

$t_{V(O)}$	Data Output Valid Time ( $V_{DD} = 4.5\text{ V to }5.5\text{ V}$ ) ( $V_{DD} = 2.3\text{ V to }4.5\text{ V}$ ) ( $V_{DD} = 1.65\text{ V to }2.3\text{ V}$ )		200 350 550		200 350 550		200 350 550	ns
$t_{SU(D)}$	Data Input Setup Time	100		100		100		ns
$t_{H(D)}$	Data Input Hold Time	1		1		1		$\mu\text{s}$

**INTERRUPT TIMING:**  $C_L \leq 100\text{ pF}$  (See Figures 9 and 10)

$t_{V(INT\_N)}$	Data Valid Time		4		4		4	$\mu\text{s}$
$t_{RST(INT\_N)}$	Reset Delay Time		4		4		4	$\mu\text{s}$

10.  $t_{VD:ACK}$  = time for Acknowledgment signal from SCL LOW to SDA (out) LOW.

11.  $t_{VD:DAT}$  = minimum time for SDA data out to be valid following SCL LOW.

12.  $C_b$  = total capacitance of one bus line in pF.

13. A master device must internally provide a hold time of at least 300 ns for the SDA signal (refer to  $V_{IL}$  of the SCL signal) in order to bridge the undefined region SCL's falling edge.

14. The maximum  $t_f$  for the SDA and SCL bus lines is specified at 300 ns. The maximum fall time for the SDA output stage  $t_f$  is specified at 250 ns. This allows series protection resistors to be connected between the SDA and the SCL pins and the SDA/SCL bus lines without exceeding the maximum specified  $t_f$ .

15. Input filters on the SDA and SCL inputs suppress noise spikes less than 50 ns.

# PCA9535E, PCA9535EC

## Device Address

Before the bus master can access a slave device, it must send the address of the slave it is accessing and the operation it wants to perform (read or write) following a START condition. The slave address of the PCA9535E and PCA9535EC is shown in Figure 5. Address pins AD2, AD1, and AD0 choose 1 of 64 slave addresses. To conserve power, no internal pull-up resistors are provided on AD2, AD1, and AD0.

A logic 1 on the last bit of the first byte selects a read operation while a logic 0 selects a write operation.

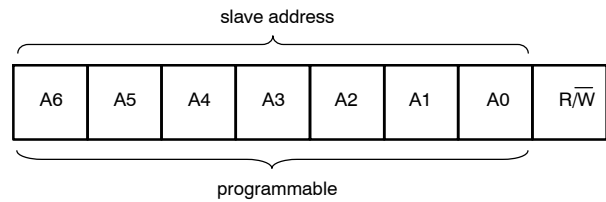


Figure 5. PCA9535E and PCA9535EC Device Address

Table 6. PCA9535E AND PCA9535EC ADDRESS MAP

Address Input			Slave Address							
AD2	AD1	AD0	A6	A5	A4	A3	A2	A1	A0	HEX
GND	SCL	GND	0	0	1	0	0	0	0	20h
GND	SCL	VDD	0	0	1	0	0	0	1	22h
GND	SDA	GND	0	0	1	0	0	1	0	24h
GND	SDA	VDD	0	0	1	0	0	1	1	26h
VDD	SCL	GND	0	0	1	0	1	0	0	28h
VDD	SCL	VDD	0	0	1	0	1	0	1	2Ah
VDD	SDA	GND	0	0	1	0	1	1	0	2Ch
VDD	SDA	VDD	0	0	1	0	1	1	1	2Eh
GND	SCL	SCL	0	0	1	1	0	0	0	30h
GND	SCL	SDA	0	0	1	1	0	0	1	32h
GND	SDA	SCL	0	0	1	1	0	1	0	34h
GND	SDA	SDA	0	0	1	1	0	1	1	36h
VDD	SCL	SCL	0	0	1	1	1	0	0	38h
VDD	SCL	SDA	0	0	1	1	1	0	1	3Ah
VDD	SDA	SCL	0	0	1	1	1	1	0	3Ch
VDD	SDA	SDA	0	0	1	1	1	1	1	3Eh
GND	GND	GND	0	1	0	0	0	0	0	40h
GND	GND	VDD	0	1	0	0	0	0	1	42h
GND	VDD	GND	0	1	0	0	0	1	0	44h
GND	VDD	VDD	0	1	0	0	0	1	1	46h
VDD	GND	GND	0	1	0	0	1	0	0	48h
VDD	GND	VDD	0	1	0	0	1	0	1	4Ah
VDD	VDD	GND	0	1	0	0	1	1	0	4Ch
VDD	VDD	VDD	0	1	0	0	1	1	1	4Eh
GND	GND	SCL	0	1	0	1	0	0	0	50h
GND	GND	SDA	0	1	0	1	0	0	1	52h
GND	VDD	SCL	0	1	0	1	0	1	0	54h
GND	VDD	SDA	0	1	0	1	0	1	1	56h
VDD	GND	SCL	0	1	0	1	1	0	0	58h
VDD	GND	SDA	0	1	0	1	1	0	1	5Ah
VDD	VDD	SCL	0	1	0	1	1	1	0	5Ch

# PCA9535E, PCA9535EC

**Table 6. PCA9535E AND PCA9535EC ADDRESS MAP**

Address Input			Slave Address							
AD2	AD1	AD0	A6	A5	A4	A3	A2	A1	A0	HEX
VDD	VDD	SDA	0	1	0	1	1	1	1	5Eh
SCL	SCL	GND	1	0	1	0	0	0	0	A0h
SCL	SCL	VDD	1	0	1	0	0	0	1	A2h
SCL	SDA	GND	1	0	1	0	0	1	0	A4h
SCL	SDA	VDD	1	0	1	0	0	1	1	A6h
SDA	SCL	GND	1	0	1	0	1	0	0	A8h
SDA	SCL	VDD	1	0	1	0	1	0	1	AAh
SDA	SDA	GND	1	0	1	0	1	1	0	ACH
SDA	SDA	VDD	1	0	1	0	1	1	1	AEnh
SCL	SCL	SCL	1	0	1	1	0	0	0	B0h
SCL	SCL	SDA	1	0	1	1	0	0	1	B2h
SCL	SDA	SCL	1	0	1	1	0	1	0	B4h
SCL	SDA	SDA	1	0	1	1	0	1	1	B6h
SDA	SCL	SCL	1	0	1	1	1	0	0	B8h
SDA	SCL	SDA	1	0	1	1	1	0	1	BAh
SDA	SDA	SCL	1	0	1	1	1	1	0	BCh
SDA	SDA	SDA	1	0	1	1	1	1	1	BEh
SCL	GND	GND	1	1	0	0	0	0	0	C0h
SCL	GND	VDD	1	1	0	0	0	0	1	C2h
SCL	VDD	GND	1	1	0	0	0	1	0	C4h
SCL	VDD	VDD	1	1	0	0	0	1	1	C6h
SDA	GND	GND	1	1	0	0	1	0	0	C8h
SDA	GND	VDD	1	1	0	0	1	0	1	CAh
SDA	VDD	GND	1	1	0	0	1	1	0	CCh
SDA	VDD	VDD	1	1	0	0	1	1	1	CEh
SCL	GND	SCL	1	1	1	0	0	0	0	E0h
SCL	GND	SDA	1	1	1	0	0	0	1	E2h
SCL	VDD	SCL	1	1	1	0	0	1	0	E4h
SCL	VDD	SDA	1	1	1	0	0	1	1	E6h
SDA	GND	SCL	1	1	1	0	1	0	0	E8h
SDA	GND	SDA	1	1	1	0	1	0	1	EAh
SDA	VDD	SCL	1	1	1	0	1	1	0	ECh
SDA	VDD	SDA	1	1	1	0	1	1	1	EEh



# PCA9535E, PCA9535EC

## REGISTERS

### Command Byte

During a write transmission, the address byte is followed by the command byte. The command byte determines which of the following registers will be written or read.

**Table 7. COMMAND BYTE**

COMMAND	REGISTER
0	Input Port 0
1	Input Port 1
2	Output Port 0
3	Output Port 1
4	Polarity Inversion Port 0
5	Polarity Inversion Port 1
6	Configuration Port 0
7	Configuration Port 1

### Registers 0 and 1: Input Port Registers

These registers are input-only. They reflect the incoming logic levels of the pins, regardless of whether the pin is defined as an input or an output by Registers 6 or 7. Writes to these registers have no effect.

The externally-applied logic level determines the default value 'X'.

**Table 8. INPUT PORT 0 REGISTER**

Bit	7	6	5	4	3	2	1	0
Symbol	I0.7	I0.6	I0.5	I0.4	I0.3	I0.2	I0.1	I0.0
Default	X	X	X	X	X	X	X	X

**Table 9. INPUT PORT 1 REGISTER**

Bit	7	6	5	4	3	2	1	0
Symbol	I1.7	I1.6	I1.5	I1.4	I1.3	I1.2	I1.1	I1.0
Default	X	X	X	X	X	X	X	X

### Registers 2 and 3: Output Port Registers

These registers are output-only. They reflect the outgoing logic levels of the pins defined as outputs by Registers 6 and 7. Bit values in these registers have no effect on pins defined

as inputs. In turn, reads from these registers reflect the values that are in the flip-flops controlling the output selection, **not** the actual pin values.

**Table 10. OUTPUT PORT 0 REGISTER**

Bit	7	6	5	4	3	2	1	0
Symbol	O0.7	O0.6	O0.5	O0.4	O0.3	O0.2	O0.1	O0.0
Default	1	1	1	1	1	1	1	1

**Table 11. OUTPUT PORT 1 REGISTER**

Bit	7	6	5	4	3	2	1	0
Symbol	O1.7	O1.6	O1.5	O1.4	O1.3	O1.2	O1.1	O1.0
Default	1	1	1	1	1	1	1	1

## PCA9535E, PCA9535EC

### Registers 4 and 5: Polarity Inversion Registers

These registers allow the polarity of the data in the input port registers to be inverted. The input port data polarity will

be inverted when its corresponding bit in these registers is set (written with '1'), and retained when the bit is cleared (written with a '0').

**Table 12. POLARITY INVERSION PORT 0 REGISTER**

Bit	7	6	5	4	3	2	1	0
Symbol	N0.7	N0.6	N0.5	N0.4	N0.3	N0.2	N0.1	N0.0
Default	0	0	0	0	0	0	0	0

**Table 13. POLARITY INVERSION PORT 1 REGISTER**

Bit	7	6	5	4	3	2	1	0
Symbol	N1.7	N1.6	N1.5	N1.4	N1.3	N1.2	N1.1	N1.0
Default	0	0	0	0	0	0	0	0

### Registers 6 and 7: Configuration Registers

The I/O pin directions are configured through the configuration registers. When a bit in the configuration registers is set (written with '1'), the bit's corresponding port

pin is enabled as an input with the output driver in high-impedance. When a bit is cleared (written with '0'), the corresponding port pin is enabled as an output. At reset, the device's ports are inputs.

**Table 14. CONFIGURATION PORT 0 REGISTER**

Bit	7	6	5	4	3	2	1	0
Symbol	C0.7	C0.6	C0.5	C0.4	C0.3	C0.2	C0.1	C0.0
Default	1	1	1	1	1	1	1	1

**Table 15. CONFIGURATION PORT 1 REGISTER**

Bit	7	6	5	4	3	2	1	0
Symbol	C1.7	C1.6	C1.5	C1.4	C1.3	C1.2	C1.1	C1.0
Default	1	1	1	1	1	1	1	1

### Power-on Reset

Upon application of power, an internal Power-On Reset (POR) holds the PCA9535E/PCA9535EC in a reset condition while  $V_{DD}$  is ramping up. When  $V_{DD}$  has reached  $V_{POR}$ , the reset condition is released and the PCA9535E/PCA9535EC registers and SMBus state machine will initialize to their default states. The reset is typically completed by the POR and the part enabled by the time the power supply is above  $V_{POR}$ . However, when doing a power reset cycle, it is necessary to lower the power supply below 0.2 V, and then restored to the operating voltage.

### I/O Port (See Figure 2)

When an I/O pin is configured as an input on the PCA9535E, FETs Q1 and Q2 are off, creating a

high-impedance input. The input voltage may be raised above  $V_{DD}$  to a maximum of 5.5 V. In the case of PCA9535EC, FET Q1 has been removed and the open-drain FET Q2 will function the same as PCA9535E.

When the I/O pin is configured as an output on the PCA9535E, then either Q1 or Q2 is enabled, depending on the state of the output port register. With the PCA9535EC, an external pullup is required to pull the I/O pin HIGH when its corresponding output port register bit is a 1. Care should be exercised if an external voltage is applied to an I/O configured as an output because of the low-impedance path that exists between the pin and either  $V_{DD}$  or  $V_{SS}$ .

# PCA9535E, PCA9535EC

## BUS TRANSACTIONS

### Writing to the Port Registers

To transmit data to the PCA9535E/PCA9535EC, the bus master must first send the device address with the least significant bit set to logic 0 (see Figure 5 “PCA9535E and PCA9535EC device address”). The command byte is sent after the address and determines which registers will receive the data following the command byte.

There are eight registers within the PCA9535E/PCA9535EC. These registers are configured to

operate as four register pairs: Input Ports, Output Ports, Polarity Inversion Ports, and Configuration Ports. Data bytes are sent alternately to each register in a register pair (see Figures 6 and 7). For example, if one byte is sent to Output Port 1 (register 3), then the next byte will be stored in Output Port 0 (register 2). There is no limitation on the number of data bytes sent in one write transmission. In this way, each 8-bit register may be updated independently of the other registers.

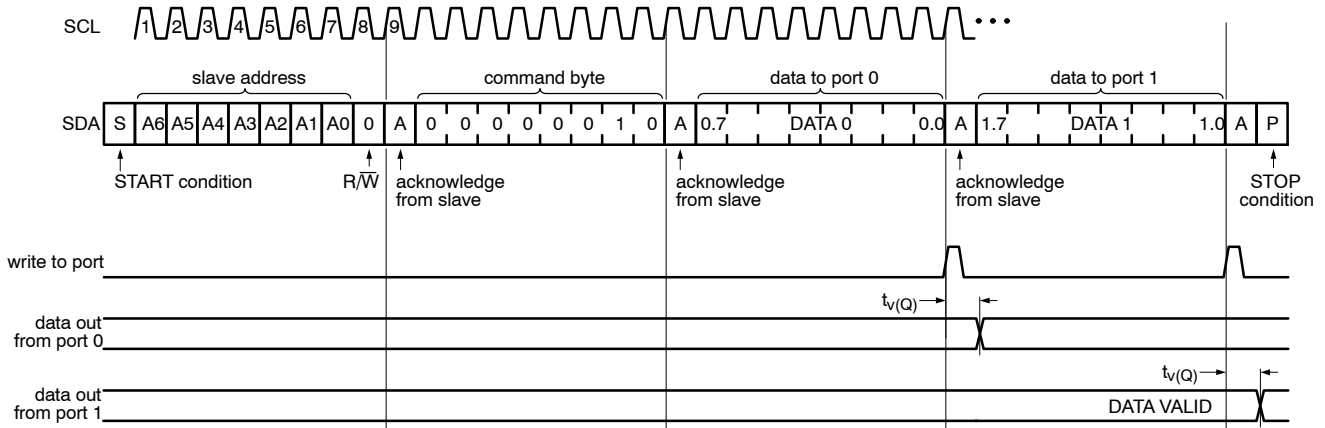


Figure 6. Write to Output Port Registers

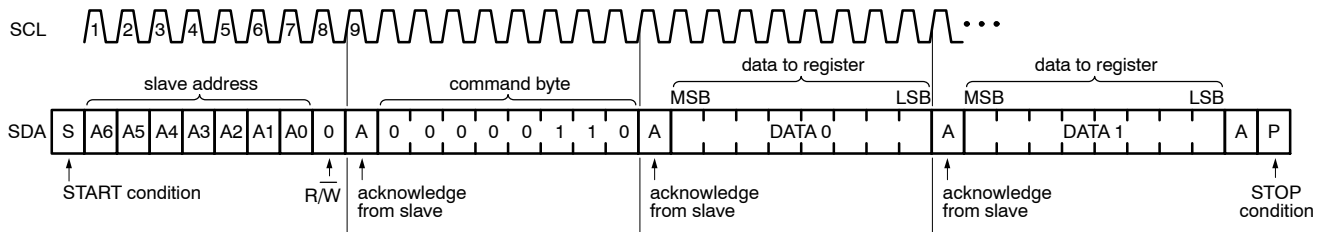


Figure 7. Write to Configuration Registers

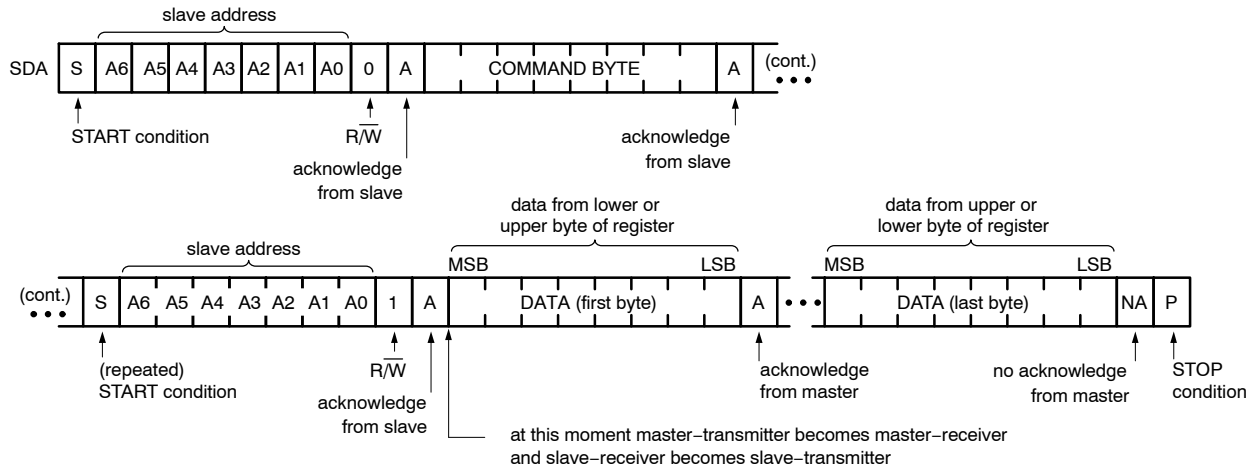
### Reading the Port Registers

To read data from the PCA9535E/PCA9535EC, the bus master must first send the PCA9535E/PCA9535EC address with the least significant bit set to logic 1 (see Figure 5 “PCA9535E and PCA9535EC device address”). The command byte is sent after the address and determines which register will be accessed.

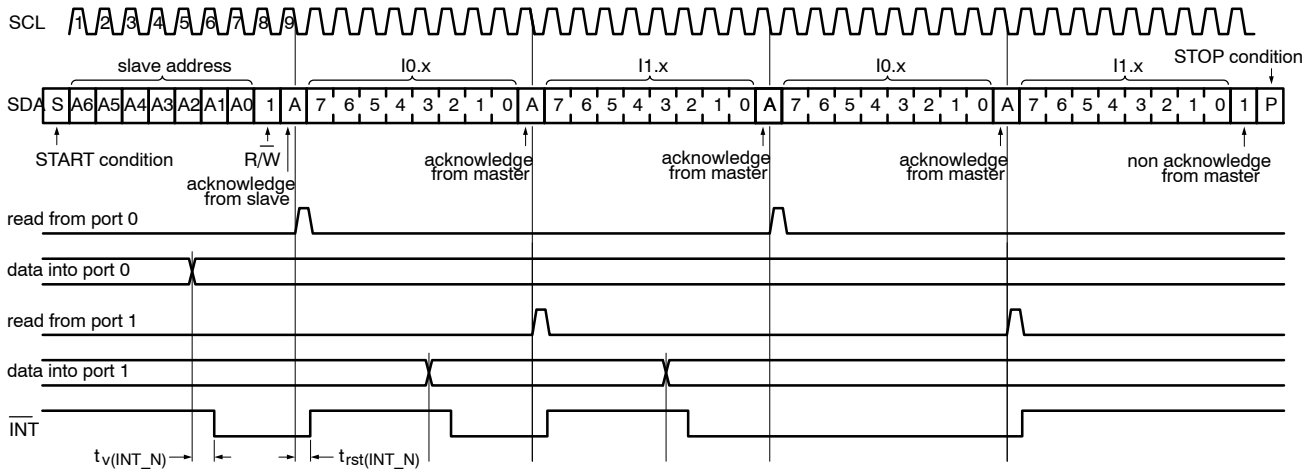
After a restart, the device address must be sent again, but this time, the least significant bit is set to logic 1. Data from the register defined by the command byte will then be sent

by the PCA9535E/PCA9535EC (see Figures 8, 9 and 10). Data is clocked into the register on the falling edge of the acknowledge clock pulse. After the first byte is read, additional bytes may be read but with data alternately coming from each register in the pair. For example, if you read Input Port 1, then the next byte read would be Input Port 0. There is no limitation on the number of data bytes received in one read transmission but the bus master must not acknowledge the data for the final byte received.

# PCA9535E, PCA9535EC

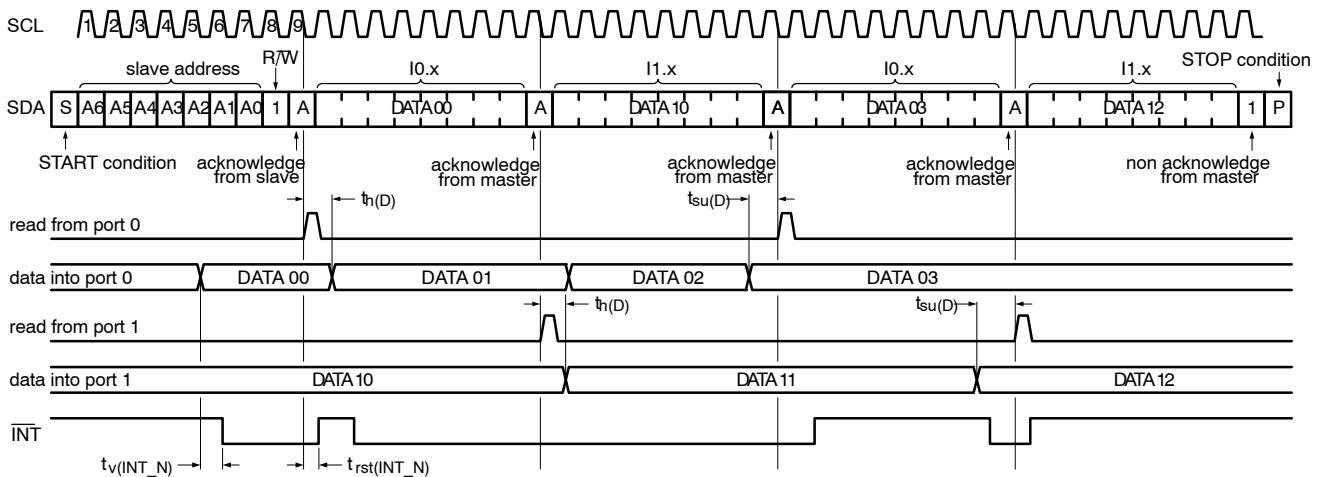


**Figure 8. Read from Register**



Remark: Transfer of data can be stopped at any moment by a STOP condition. When this occurs, data present at the latest acknowledge phase is valid (output mode). It is assumed that the command byte has previously been set to '00' (read Input Port register).

**Figure 9. Read from Input Port Register, Scenario 1**



Remark: Transfer of data can be stopped at any moment by a STOP condition. When this occurs, data present at the latest acknowledge phase is valid (output mode). It is assumed that the command byte has previously been set to '00' (read Input Port register).

**Figure 10. Read from Input Port Register, Scenario 2**

# PCA9535E, PCA9535EC

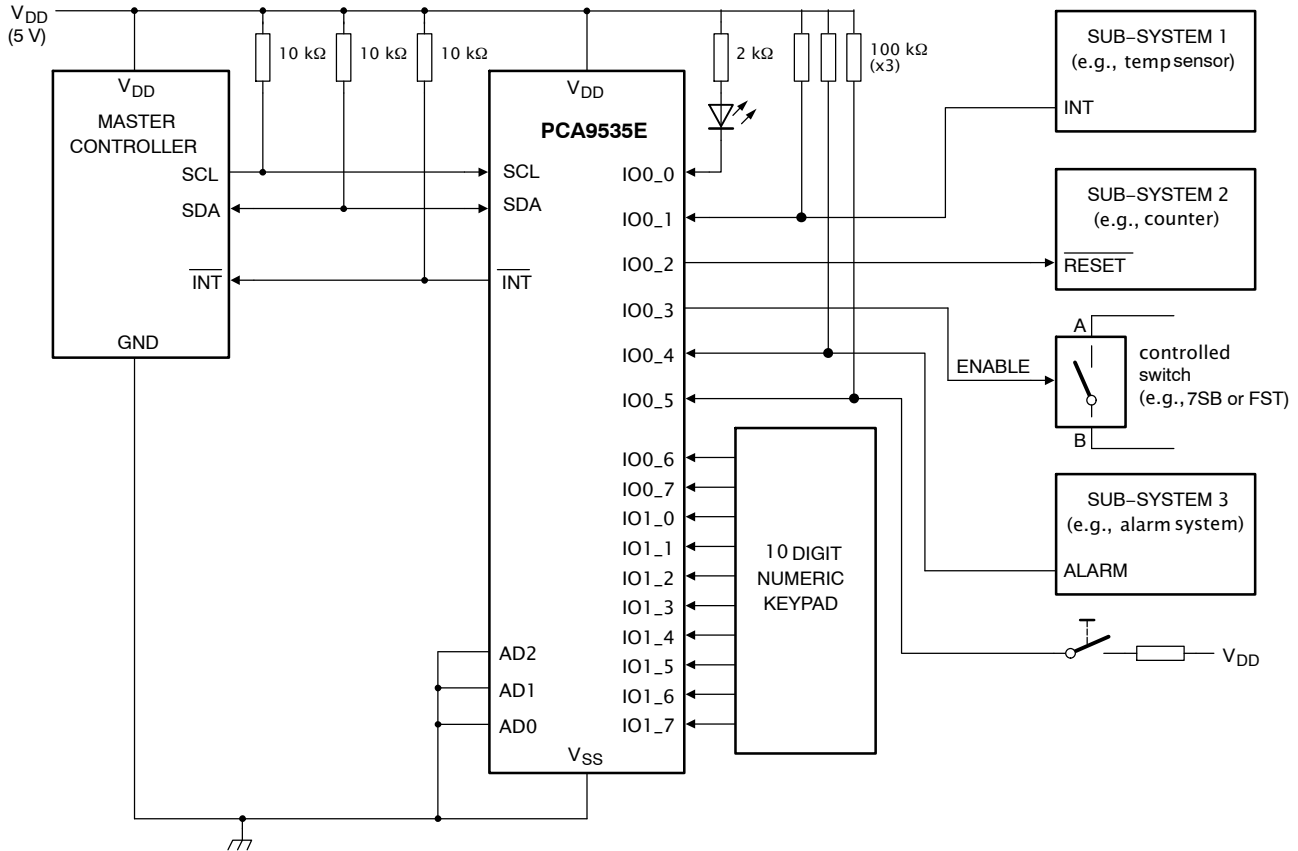
## Interrupt Output

The open-drain interrupt output is activated when an I/O pin configured as an input changes state. The interrupt is deactivated when the input pin returns to its previous state or when the Input Port register is read (see Figure 9). A pin configured as an output cannot cause an interrupt. Since

each 8-bit port is read independently, the interrupt caused by Port 0 will not be cleared by a read of Port 1 or the other way around.

**Remark:** Changing an I/O from an output to an input may cause a false interrupt to occur if the state of the pin does not match the contents of the Input Port register.

## APPLICATION INFORMATION



Device address configured as 0100 000xb for this example.

IO0\_0, IO0\_2, IO0\_3 configured as outputs.

IO0\_1, IO0\_4, IO0\_5 configured as inputs.

IO0\_6, IO0\_7, and IO1\_0 to IO1\_7 configured as inputs.

**Figure 11. Typical Application**

## Minimizing I<sub>DD</sub> When the I/Os are Used to Control LEDs

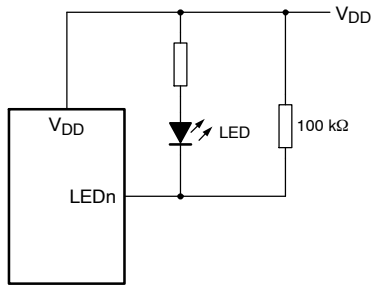
To use the PCA9535E I/Os to control LEDs, the I/Os are normally connected to V<sub>DD</sub> through a resistor as shown in Figure 11. The LED acts as a diode. When the LED is off, the I/O V<sub>I</sub> is about 1.2 V less than V<sub>DD</sub>. The supply current, I<sub>DD</sub>, increases as V<sub>I</sub> becomes lower than V<sub>DD</sub>.

For applications requiring low current consumption, such as battery power applications, it is recommended that the I/O

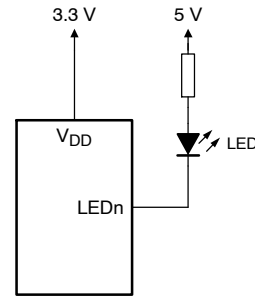
pin voltages be greater than or equal to V<sub>DD</sub> when the LED is off. This would minimize current consumption. Figure 12 shows a high value resistor in parallel with the LED. Figure 13 shows V<sub>DD</sub> less than the LED supply voltage by at least 1.2 V. Both of these methods maintain the I/O V<sub>I</sub> at or above V<sub>DD</sub> and prevents additional supply current consumption when the LED is off.

This concern does not occur for the PCA9535EC because the PCA9535EC I/O pins are open-drain.

## PCA9535E, PCA9535EC



**Figure 12. High Value Resistor in Parallel with the LED**



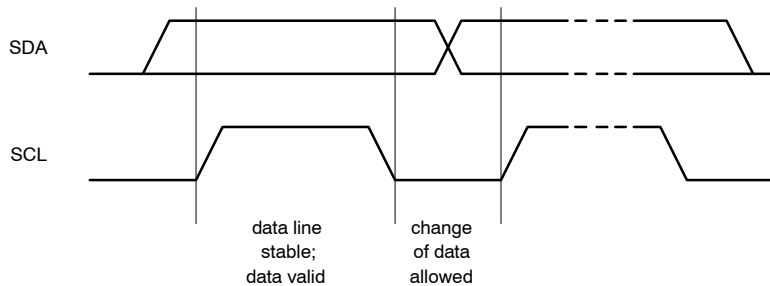
**Figure 13. Device Supplied by a Lower Voltage**

### Characteristics of the I<sup>2</sup>C-bus

The I<sup>2</sup>C-bus is meant for 2-way, 2-line communication between different ICs or modules. The two lines are the serial data line (SDA) and the serial clock line (SCL). Both lines must be connected to a positive supply via a pull-up resistor when connected to the output stages of a device. Data transfer may only be initiated when the bus is not busy.

### Bit transfer

One data bit is transferred during each clock pulse. The data on the SDA line must remain stable during the HIGH period of the clock pulse. Changes in the data line during the HIGH period of the clock pulse will be interpreted as control signals (see Figure 14).

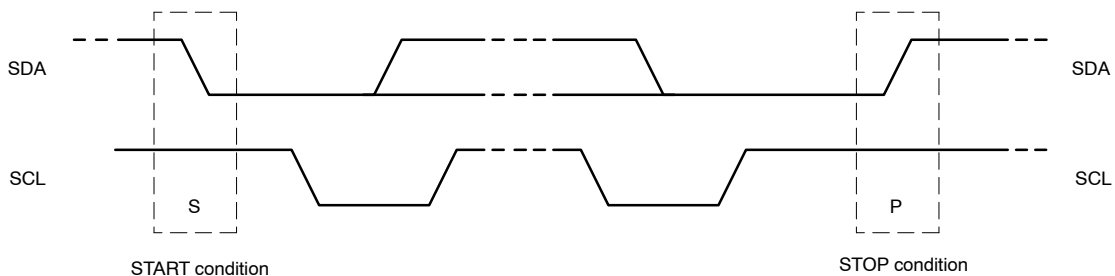


**Figure 14. Bit Transfer**

### START and STOP conditions

Both data and clock lines remain HIGH when the bus is not busy. A START condition (S) occurs when there is a HIGH-to-LOW transition of the data line while the clock is

HIGH. A STOP condition (P) occurs when there is a LOW-to-HIGH transition of the data line while the clock is HIGH (see Figure 15).



**Figure 15. Definition of START and STOP Conditions**

**System Configuration**

A device generating a message is a 'transmitter'; a device receiving is the 'receiver'. The device that controls the

message is the 'master' and the devices which are controlled by the master are the 'slaves' (see Figure 16).

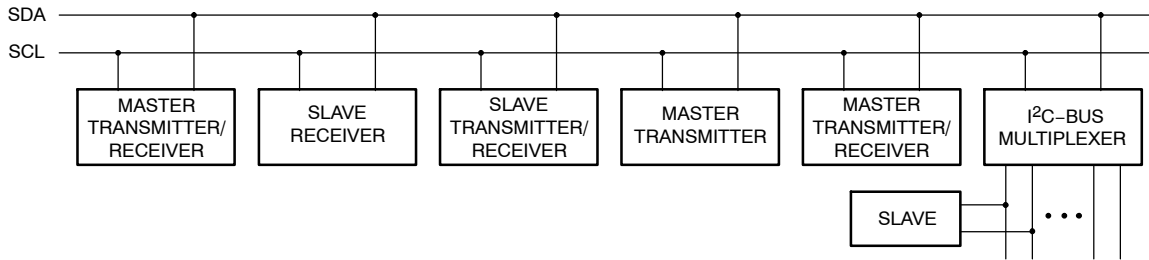


Figure 16. System Configuration

**Acknowledge**

The number of data bytes transferred between the START and the STOP conditions from transmitter to receiver is not limited. Each 8-bit byte is followed by one acknowledge bit. The acknowledge bit is a HIGH level put on the bus by the transmitter, whereas the master generates an extra clock pulse for the acknowledge bit.

A slave receiver which is addressed must generate an acknowledge after the reception of each byte. Also a master must generate an acknowledge after the reception of each byte that has been clocked out of the slave transmitter. The

device that acknowledges has to pull down the SDA line during the acknowledge clock pulse, such that the SDA line is stable LOW during the HIGH period of the acknowledge clock pulse; set-up time and hold time must be taken into account.

A master receiver signals an end of data to the transmitter by not generating an acknowledge on the last byte that has been clocked out of the slave. In this event, the transmitter must leave the data line HIGH to enable the master to generate a STOP condition.

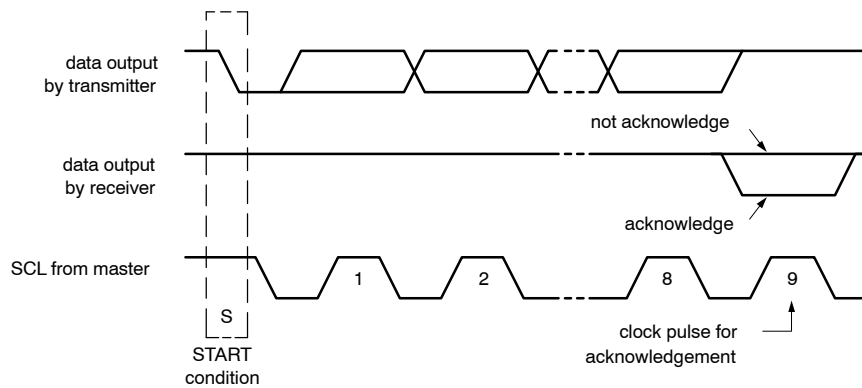


Figure 17. Acknowledgement of the I2C Bus

**Timing and Test Setup**

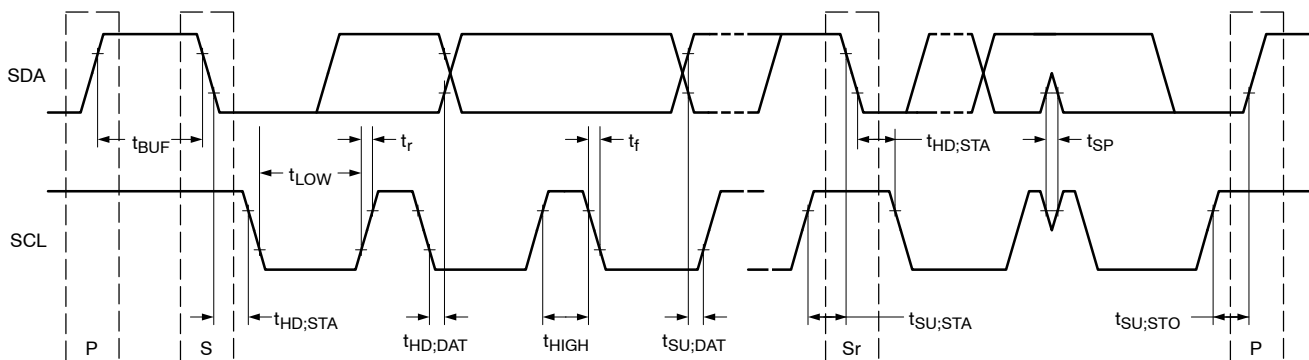
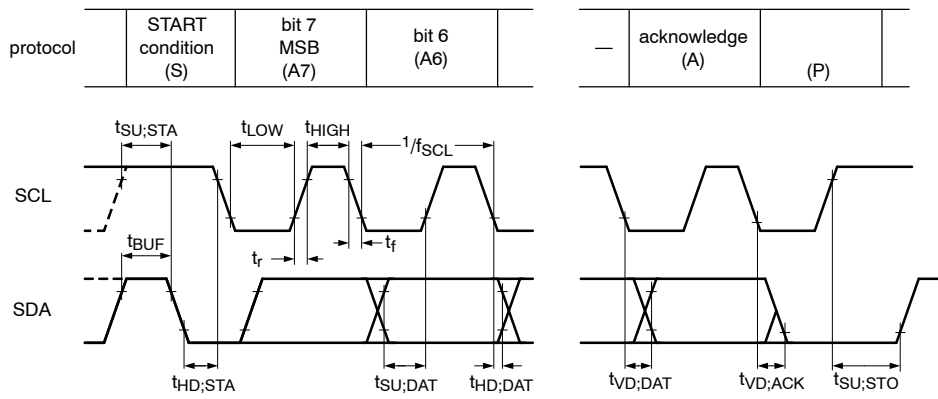


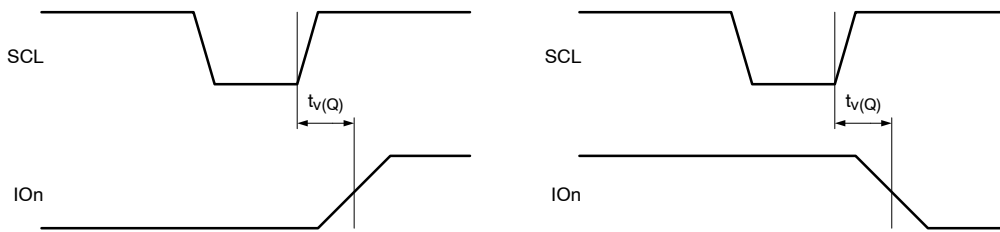
Figure 18. Definition of Timing on the I2C Bus

# PCA9535E, PCA9535EC

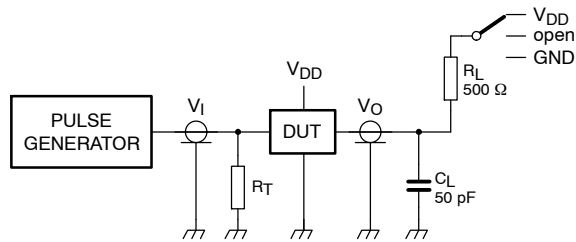


Rise and fall times refer to  $V_{IL}$  and  $V_{IH}$

**Figure 19. I<sup>2</sup>C Bus Timing Diagram**



**Figure 20.  $t_{v(Q)}$  Timing**

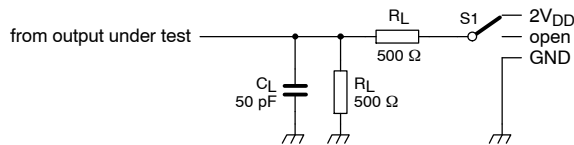


$R_L$  = load resistor.

$C_L$  = load capacitance includes jig and probe capacitance.

$R_T$  = termination resistance should be equal to the output impedance of  $Z_o$  of the pulse generators.

**Figure 21. Test Circuitry for Switching Times**



**Figure 22. Load Circuit**



## PCA9535E, PCA9535EC

### ORDERING INFORMATION

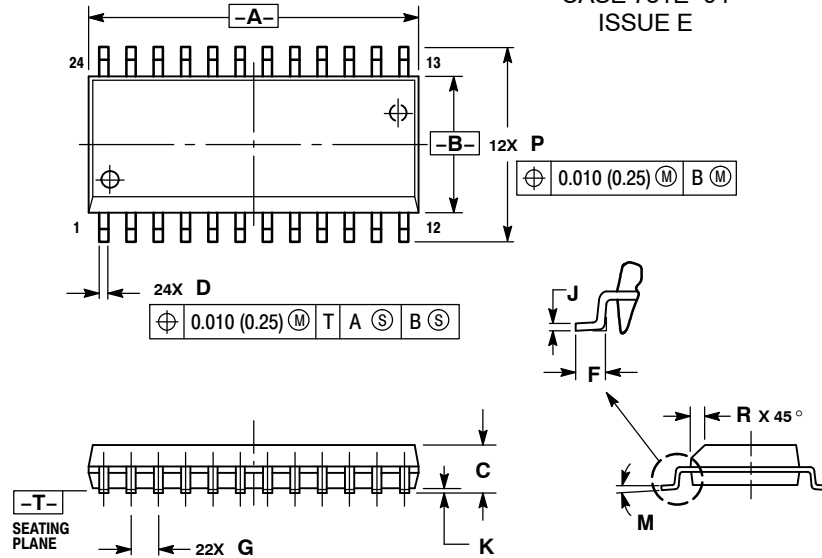
Device	Package	Shipping†
PCA9535EDWR2G	SOIC-24 (Pb-Free)	1000 / Tape & Reel
PCA9535EDTR2G	TSSOP-24 (Pb-Free)	2500 / Tape & Reel
PCA9535EMTTXG	WQFN24 (Pb-Free)	3000 / Tape & Reel
PCA9535ECDWR2G	SOIC-24 (Pb-Free)	1000 / Tape & Reel
PCA9535ECDTR2G	TSSOP-24 (Pb-Free)	2500 / Tape & Reel
PCA9535ECMTTXG	WQFN24 (Pb-Free)	3000 / Tape & Reel

†For information on tape and reel specifications, including part orientation and tape sizes, please refer to our Tape and Reel Packaging Specifications Brochure, BRD8011/D.

# PCA9535E, PCA9535EC

## PACKAGE DIMENSIONS

### SOIC-24 CASE 751E-04 ISSUE E



#### NOTES:

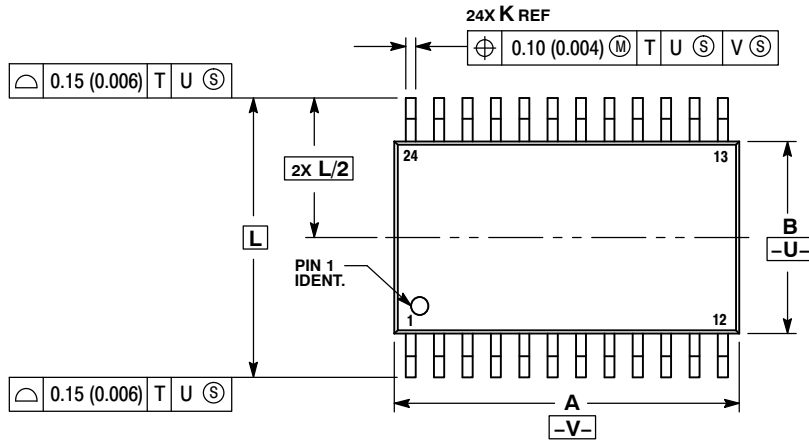
1. DIMENSIONING AND TOLERANCING PER ANSI Y14.5M, 1982.
2. CONTROLLING DIMENSION: MILLIMETER.
3. DIMENSIONS A AND B DO NOT INCLUDE MOLD PROTRUSION.
4. MAXIMUM MOLD PROTRUSION 0.15 (0.006) PER SIDE.
5. DIMENSION D DOES NOT INCLUDE DAMBAR PROTRUSION. ALLOWABLE DAMBAR PROTRUSION SHALL BE 0.13 (0.005) TOTAL IN EXCESS OF D DIMENSION AT MAXIMUM MATERIAL CONDITION.

DIM	MILLIMETERS		INCHES	
	MIN	MAX	MIN	MAX
A	15.25	15.54	0.601	0.612
B	7.40	7.60	0.292	0.299
C	2.35	2.65	0.093	0.104
D	0.35	0.49	0.014	0.019
F	0.41	0.90	0.016	0.035
G	1.27 BSC		0.050 BSC	
J	0.23	0.32	0.009	0.013
K	0.13	0.29	0.005	0.011
M	0°	8°	0°	8°
P	10.05	10.55	0.395	0.415
R	0.25	0.75	0.010	0.029

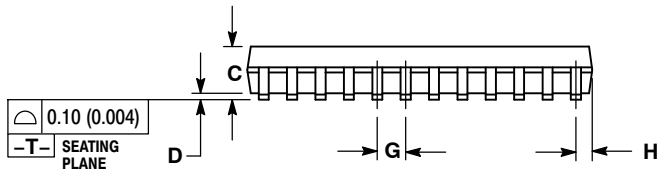
# PCA9535E, PCA9535EC

## PACKAGE DIMENSIONS

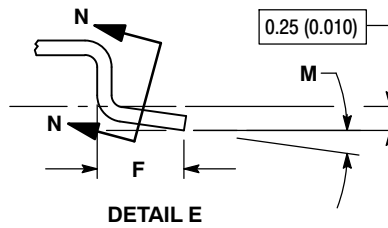
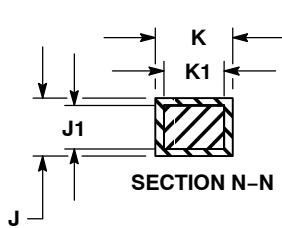
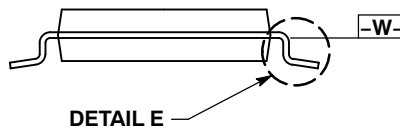
### 24 LEAD TSSOP CASE 948H ISSUE A



- NOTES:
1. DIMENSIONING AND TOLERANCING PER ANSI Y14.5M, 1982.
  2. CONTROLLING DIMENSION: MILLIMETER.
  3. DIMENSION A DOES NOT INCLUDE MOLD FLASH, PROTRUSIONS OR GATE BURRS. MOLD FLASH OR GATE BURRS SHALL NOT EXCEED 0.15 (0.006) PER SIDE.
  4. DIMENSION B DOES NOT INCLUDE INTERLEAD FLASH OR PROTRUSION. INTERLEAD FLASH OR PROTRUSION SHALL NOT EXCEED 0.25 (0.010) PER SIDE.
  5. DIMENSION K DOES NOT INCLUDE DAMBAR PROTRUSION. ALLOWABLE DAMBAR PROTRUSION SHALL BE 0.08 (0.003) TOTAL IN EXCESS OF THE K DIMENSION AT MAXIMUM MATERIAL CONDITION.
  6. TERMINAL NUMBERS ARE SHOWN FOR REFERENCE ONLY.
  7. DIMENSION A AND B ARE TO BE DETERMINED AT DATUM PLANE -W-.



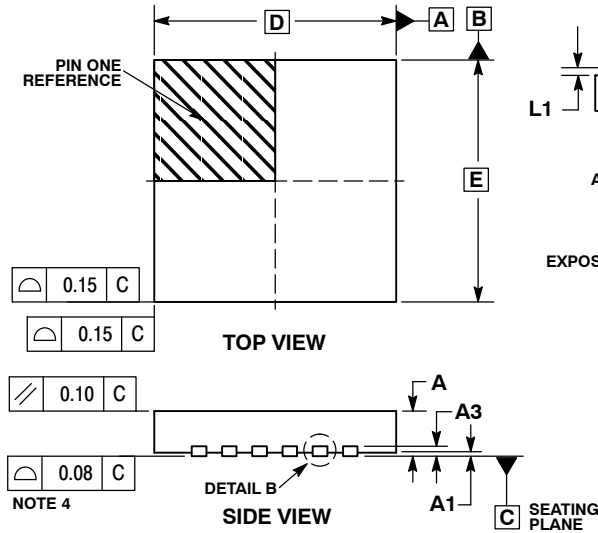
DIM	MILLIMETERS		INCHES	
	MIN	MAX	MIN	MAX
A	7.70	7.90	0.303	0.311
B	4.30	4.50	0.169	0.177
C	---	1.20	---	0.047
D	0.05	0.15	0.002	0.006
F	0.50	0.75	0.020	0.030
G	0.65 BSC		0.026 BSC	
H	0.27	0.37	0.011	0.015
J	0.09	0.20	0.004	0.008
J1	0.09	0.16	0.004	0.006
K	0.19	0.30	0.007	0.012
K1	0.19	0.25	0.007	0.010
L	6.40 BSC		0.252 BSC	
M	0°	8°	0°	8°



# PCA9535E, PCA9535EC

## PACKAGE DIMENSIONS

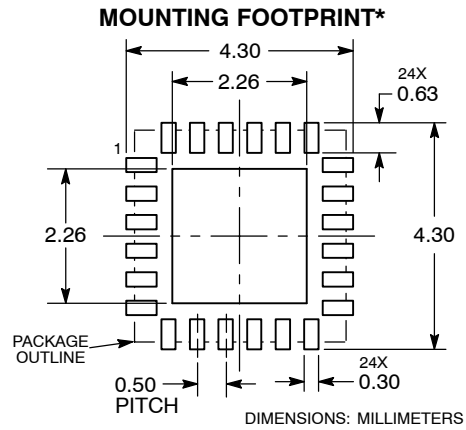
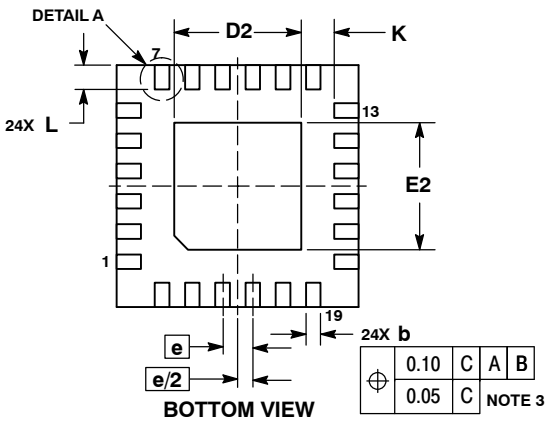
WQFN24 4x4, 0.5P  
CASE 485BG  
ISSUE A



**NOTES:**

1. DIMENSIONING AND TOLERANCING PER ASME Y14.5M, 1994.
2. CONTROLLING DIMENSION: MILLIMETERS.
3. DIMENSION b APPLIES TO PLATED TERMINAL AND IS MEASURED BETWEEN 0.15 AND 0.30 MM FROM TERMINAL TIP.
4. COPLANARITY APPLIES TO THE EXPOSED PAD AS WELL AS THE TERMINALS.

DIM	MILLIMETERS	
	MIN	MAX
A	0.70	0.80
A1	0.00	0.05
A3	0.20 REF	
b	0.20	0.30
D	4.00 BSC	
D2	2.00	2.20
E	4.00 BSC	
E2	2.00	2.20
e	0.50 BSC	
K	0.20	---
L	0.30	0.50
L1	0.00	0.15



\*For additional information on our Pb-Free strategy and soldering details, please download the ON Semiconductor Soldering and Mounting Techniques Reference Manual, SOLDERRM/D.

ON Semiconductor and are registered trademarks of Semiconductor Components Industries, LLC (SCILLC). SCILLC reserves the right to make changes without further notice to any products herein. SCILLC makes no warranty, representation or guarantee regarding the suitability of its products for any particular purpose, nor does SCILLC assume any liability arising out of the application or use of any product or circuit, and specifically disclaims any and all liability, including without limitation special, consequential or incidental damages. "Typical" parameters which may be provided in SCILLC data sheets and/or specifications can and do vary in different applications and actual performance may vary over time. All operating parameters, including "Typicals" must be validated for each customer application by customer's technical experts. SCILLC does not convey any license under its patent rights nor the rights of others. SCILLC products are not designed, intended, or authorized for use as components in systems intended for surgical implant into the body, or other applications intended to support or sustain life, or for any other application in which the failure of the SCILLC product could create a situation where personal injury or death may occur. Should Buyer purchase or use SCILLC products for any such unintended or unauthorized application, Buyer shall indemnify and hold SCILLC and its officers, employees, subsidiaries, affiliates, and distributors harmless against all claims, costs, damages, and expenses, and reasonable attorney fees arising out of, directly or indirectly, any claim of personal injury or death associated with such unintended or unauthorized use, even if such claim alleges that SCILLC was negligent regarding the design or manufacture of the part. SCILLC is an Equal Opportunity/Affirmative Action Employer. This literature is subject to all applicable copyright laws and is not for resale in any manner.

### PUBLICATION ORDERING INFORMATION

**LITERATURE FULFILLMENT:**  
Literature Distribution Center for ON Semiconductor  
P.O. Box 5163, Denver, Colorado 80217 USA  
Phone: 303-675-2175 or 800-344-3860 Toll Free USA/Canada  
Fax: 303-675-2176 or 800-344-3867 Toll Free USA/Canada  
Email: orderlit@onsemi.com

**N. American Technical Support:** 800-282-9855 Toll Free  
USA/Canada  
**Europe, Middle East and Africa Technical Support:**  
Phone: 421 33 790 2910  
**Japan Customer Focus Center**  
Phone: 81-3-5817-1050

**ON Semiconductor Website:** [www.onsemi.com](http://www.onsemi.com)  
**Order Literature:** <http://www.onsemi.com/orderlit>

For additional information, please contact your local Sales Representative

Компания «Океан Электроники» предлагает заключение долгосрочных отношений при поставках импортных электронных компонентов на взаимовыгодных условиях!

Наши преимущества:

- Поставка оригинальных импортных электронных компонентов напрямую с производств Америки, Европы и Азии, а так же с крупнейших складов мира;
- Широкая линейка поставок активных и пассивных импортных электронных компонентов (более 30 млн. наименований);
- Поставка сложных, дефицитных, либо снятых с производства позиций;
- Оперативные сроки поставки под заказ (от 5 рабочих дней);
- Экспресс доставка в любую точку России;
- Помощь Конструкторского Отдела и консультации квалифицированных инженеров;
- Техническая поддержка проекта, помощь в подборе аналогов, поставка прототипов;
- Поставка электронных компонентов под контролем ВП;
- Система менеджмента качества сертифицирована по Международному стандарту ISO 9001;
- При необходимости вся продукция военного и аэрокосмического назначения проходит испытания и сертификацию в лаборатории (по согласованию с заказчиком);
- Поставка специализированных компонентов военного и аэрокосмического уровня качества (Xilinx, Altera, Analog Devices, Intersil, Interpoint, Microsemi, Actel, Aeroflex, Peregrine, VPT, Syfer, Eurofarad, Texas Instruments, MS Kennedy, Miteq, Cobham, E2V, MA-COM, Hittite, Mini-Circuits, General Dynamics и др.);

Компания «Океан Электроники» является официальным дистрибьютором и эксклюзивным представителем в России одного из крупнейших производителей разъемов военного и аэрокосмического назначения «JONHON», а так же официальным дистрибьютором и эксклюзивным представителем в России производителя высокотехнологичных и надежных решений для передачи СВЧ сигналов «FORSTAR».



## JONHON

«JONHON» (основан в 1970 г.)

Разъемы специального, военного и аэрокосмического назначения:

(Применяются в военной, авиационной, аэрокосмической, морской, железнодорожной, горно- и нефтедобывающей отраслях промышленности)

«FORSTAR» (основан в 1998 г.)

ВЧ соединители, коаксиальные кабели,  
кабельные сборки и микроволновые компоненты:

(Применяются в телекоммуникациях гражданского и специального назначения, в средствах связи, РЛС, а так же военной, авиационной и аэрокосмической отраслях промышленности).



Телефон: 8 (812) 309-75-97 (многоканальный)

Факс: 8 (812) 320-03-32

Электронная почта: [ocean@oceanchips.ru](mailto:ocean@oceanchips.ru)

Web: <http://oceanchips.ru/>

Адрес: 198099, г. Санкт-Петербург, ул. Калинина, д. 2, корп. 4, лит. А