

# High Frequency Ceramic Solutions

## 434MHz Impedance-Matched Balun+Filter Integrated Passive Device (IPD) for Silicon Labs EFR32 Chipset, EIA 0805.

0434BM15B0027

Detail Specification: 2/26/2018

Page 1 of 6

Do you need a small sub-GHz or 2.4GHz antenna? Go to: [www.johansontechnology.com/antennas](http://www.johansontechnology.com/antennas)

### General Specifications

Part Number	0434BM15B0027	
Frequency (MHz)	431 - 437	
Unbalanced Impedance ( $\Omega$ )	50	
Balanced Impedance ( $\Omega$ )	Impedance matched to Silicon Labs EFR32	
Insertion Loss (dB)	2.0 typ. (2.3 max)	
Return Loss (dB)	15 typ. (10 min)	
Phase Balance (deg)	$-155 \pm 15$	
Amplitude Difference (dB)	$-5.0 \pm 2.0$	
Attenuation (dB @MHz)	22 typ. (18 min.)	862 - 874 MHz
	35 typ. (30 min.)	1293 - 1311 MHz
Voltage Rating (V)	3.6 max.	
Power Capacity (W)	3 max. CW	
Operating Temperature	$-40^{\circ}\text{C}$ to $+85^{\circ}\text{C}$	

The entire sub-GHz discrete L/C circuit is integrated inside this small package!

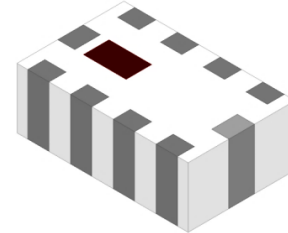

Silicon Labs Approved!

Quantity/Reel	4,000
Storage Temperature Range	$-40^{\circ}\text{C}$ to $+85^{\circ}\text{C}$
Storage Period	18 months max
Recommended Storage Conditions for unused T&R product	$+5 \sim +35^{\circ}\text{C}$ , Humidity 45~75%RH, 18 mos. max

For more Silicon Labs matched balun-filters, go to: [www.johansontechnology.com/silabs](http://www.johansontechnology.com/silabs)

### Part Number Explanation

P/N Suffix	Packing Style	Bulk	Suffix = S	eg. 0434BM15B0027S
		T & R	Suffix = E	eg. 0434BM15B0027E

### Mechanical Dimensions

	In	mm
L	$0.079 \pm 0.008$	$2.00 \pm 0.20$
W	$0.049 \pm 0.008$	$1.25 \pm 0.20$
T	$0.028 \pm 0.004$	$0.70 \pm 0.10$
a	$0.010 \pm 0.004$	$0.25 \pm 0.10$
b	$0.012 \pm 0.006$	$0.30 \pm 0.15$
c	$0.008 +0.004/-0.006$	$0.20 +0.1/-0.15$
d	$0.020 \pm 0.004$	$0.50 \pm 0.10$

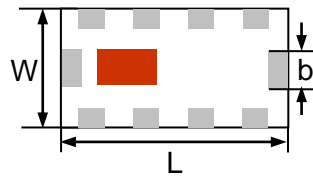

Top

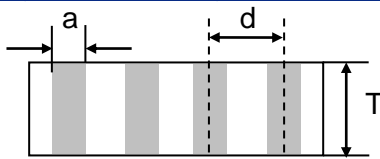

Side

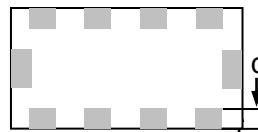

Bottom

### Terminal Configuration

No.	Function	No.	Function
1	GND	6	RX_N
2	ANT	7	RX_P
3	GND	8	TX_N
4	GND	9	TX_P
5	GND	10	GND or DC Feed/GND

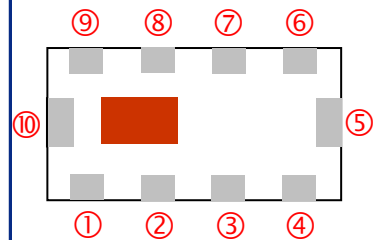

Johanson Technology, Inc. reserves the right to make design changes without notice.

All sales are subject to Johanson Technology, Inc. terms and conditions.



[www.johansontechnology.com](http://www.johansontechnology.com)

4001 Calle Tecate • Camarillo, CA 93012 • TEL 805.389.1166 FAX 805.389.1821

Ver. 1.0

2018 Johanson Technology, Inc. All Rights Reserved

# High Frequency Ceramic Solutions

**434MHz Impedance-Matched Balun+Filter Integrated Passive Device (IPD) for Silicon Labs EFR32 Chipset, EIA 0805.**

**0434BM15B0027**

Detail Specification: 2/26/2018

Page 2 of 6

## Pad-Soldermask Guidelines (with DC Feed)

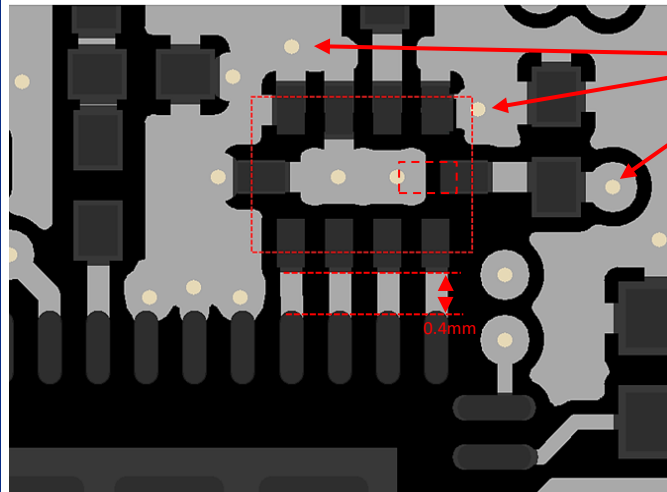

GND vias are crucial for filter harmonic attenuation

- GND
- Solder Pads
- GND via ( $\phi$  0.20)

For reference design package and PCB CAD files, please contact us at:  
[www.johansontechnology.com/ask-a-question](http://www.johansontechnology.com/ask-a-question)

## PCB Reference Design Schematic

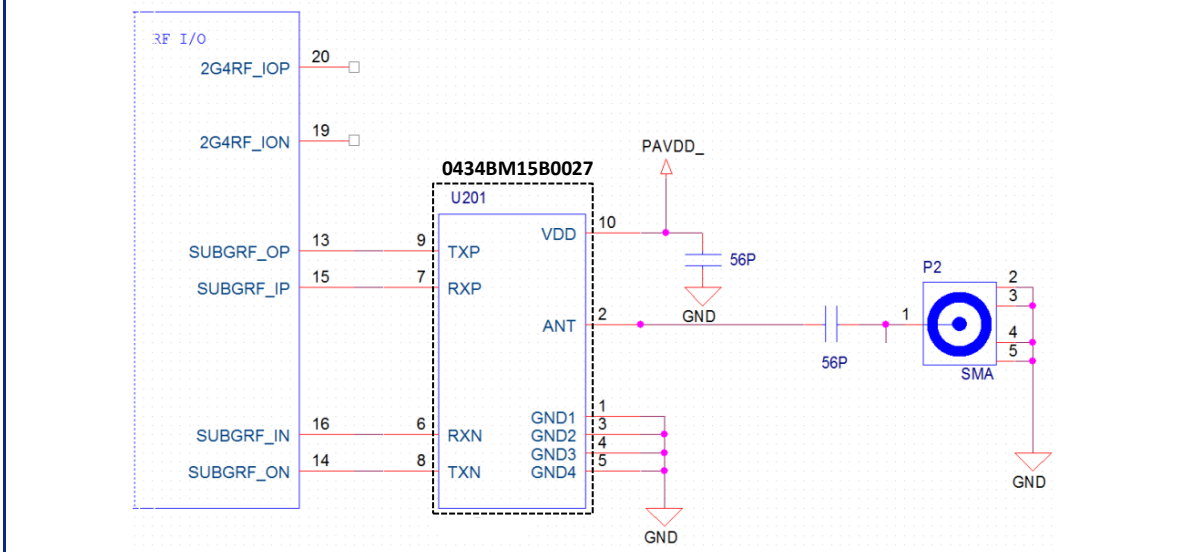

Johanson Technology, Inc. reserves the right to make design changes without notice.  
All sales are subject to Johanson Technology, Inc. terms and conditions.



[www.johansontechnology.com](http://www.johansontechnology.com)  
4001 Calle Tecate • Camarillo, CA 93012 • TEL 805.389.1166 FAX 805.389.1821  
Ver. 1.0 2018 Johanson Technology, Inc. All Rights Reserved

# High Frequency Ceramic Solutions

**434MHz Impedance-Matched Balun+Filter Integrated Passive Device (IPD) for Silicon Labs EFR32 Chipset, EIA 0805.**

**0434BM15B0027**

Detail Specification: 2/26/2018

Page 3 of 6

## Measuring Diagram

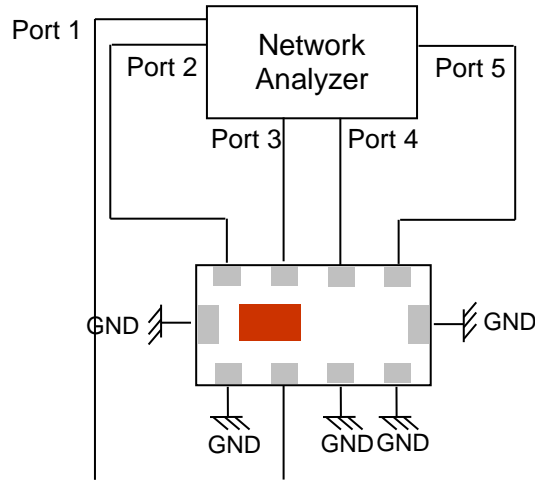

### Tx mode:

Port 1 impedance:  $50\Omega$

Port 2 and 3 impedance\*: Complex conjugate to EFR32  $Z_{IC,TX\ on}$

Port 4 and 5 impedance\*: Load impedance of EFR32  $Z_{IC,RX\ off}$

$$IL=TX\ S_{DS21}$$

$$RL=TX\ S_{SS11} / TX\ S_{DD22}$$

$$\text{Amplitude Difference} = dB(S(1,2)/S(1,3))$$

$$\text{Phase Balance} = \text{Phase}(S(1,2)/S(1,3))$$

### Rx mode:

Port 1 impedance:  $50\Omega$

Port 4 and 5 impedance\*: Complex conjugate to EFR32  $Z_{IC,RX\ on}$

Port 2 and 3 impedance\*: Load impedance of EFR32  $Z_{IC,TX\ off}$

$$IL=RX\ S_{DS21}$$

$$RL=RX\ S_{SS11} / RX\ S_{DD22}$$

$$\text{Amp\_balance} = dB(S(1,4)/S(1,5))$$

$$\text{Phase\_balance} = \text{Phase}(S(1,4)/S(1,5))$$

\*Termination impedance included in s-parameters

Johanson Technology, Inc. reserves the right to make design changes without notice.

All sales are subject to Johanson Technology, Inc. terms and conditions.



[www.johansontechnology.com](http://www.johansontechnology.com)

4001 Calle Tecate • Camarillo, CA 93012 • TEL 805.389.1166 FAX 805.389.1821

Ver. 1.0

2018 Johanson Technology, Inc. All Rights Reserved

# High Frequency Ceramic Solutions

434MHz Impedance-Matched Balun+Filter Integrated Passive Device (IPD) for Silicon Labs EFR32 Chipset, EIA 0805.

0434BM15B0027

Detail Specification: 2/26/2018

Page 4 of 6

## Typical Electrical Characteristics (T=25°C)

### Transmit Mode Insertion Loss, Return Loss, and Attenuation

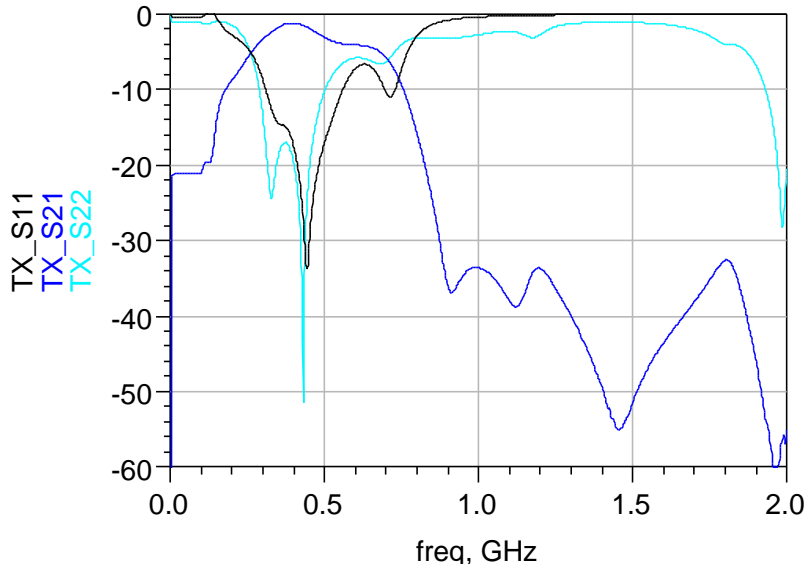

### Transmit Mode Phase Balance, Amplitude Difference

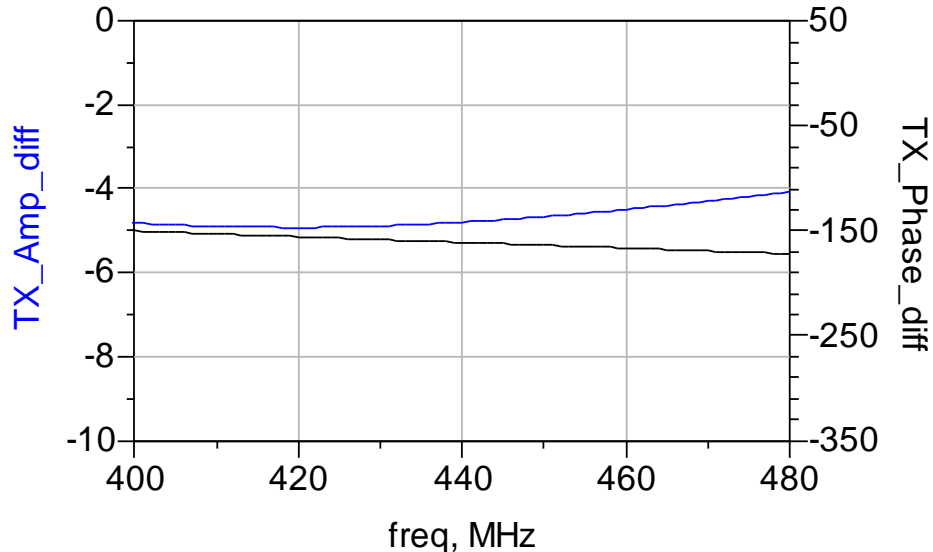

Johanson Technology, Inc. reserves the right to make design changes without notice.

All sales are subject to Johanson Technology, Inc. terms and conditions.



# High Frequency Ceramic Solutions

434MHz Impedance-Matched Balun+Filter Integrated Passive Device  
(IPD) for Silicon Labs EFR32 Chipset, EIA 0805.

0434BM15B0027

Detail Specification: 2/26/2018

Page 5 of 6

## Typical Electrical Characteristics (T=25°C)

### Receive Mode Insertion Loss, Return Loss, and Attenuation

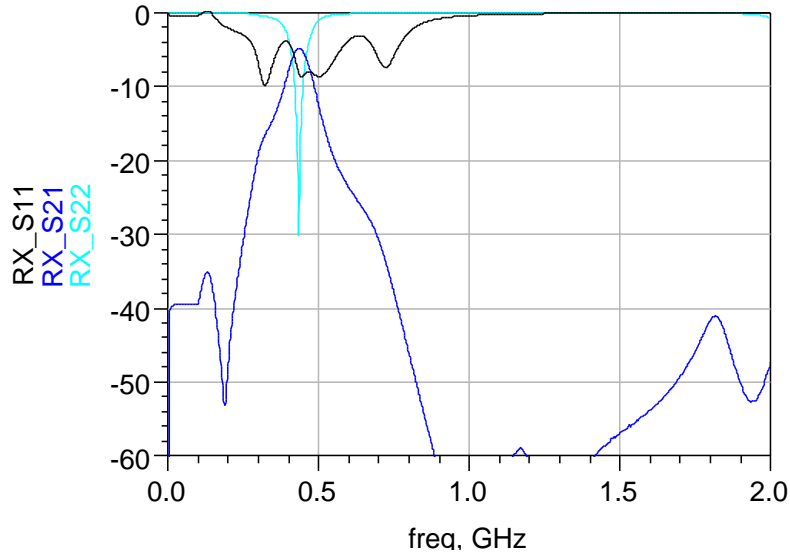

### Receive Mode Phase Balance, Amplitude Difference

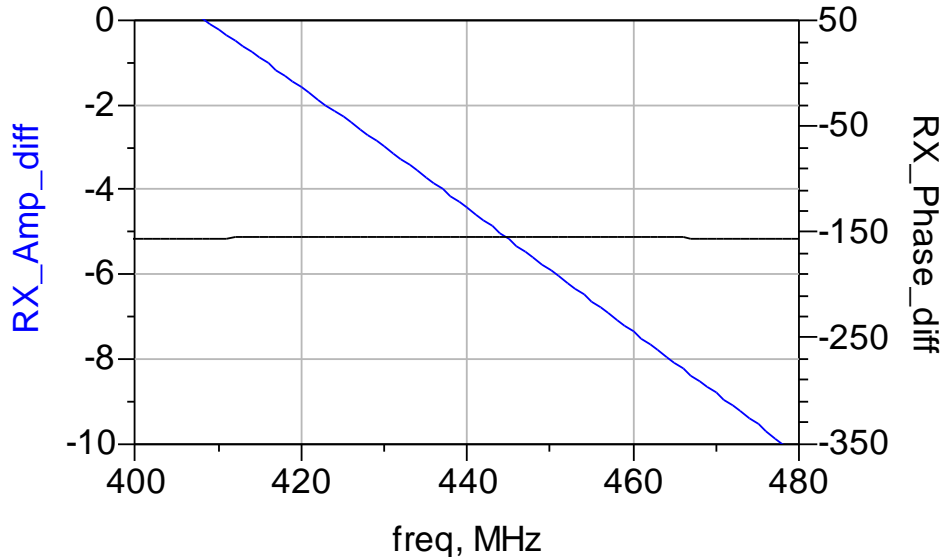

Johanson Technology, Inc. reserves the right to make design changes without notice.  
All sales are subject to Johanson Technology, Inc. terms and conditions.



# High Frequency Ceramic Solutions

**434MHz Impedance-Matched Balun+Filter Integrated Passive Device (IPD) for Silicon Labs EFR32 Chipset, EIA 0805.**

**0434BM15B0027**

Detail Specification: 2/26/2018

Page 6 of 6

## Application Notes, Layout Files, and more

[www.johansontechnology.com/silabs](http://www.johansontechnology.com/silabs)

## Small SMD 433MHz (or 900M, 2.4G, 5G) antennas

[www.johansontechnology.com/antennas](http://www.johansontechnology.com/antennas)

## RoHS Compliance

[www.johansontechnology.com/rohs-compliance](http://www.johansontechnology.com/rohs-compliance)

## Soldering Information

[www.johansontechnology.com/ipcsoldering-profile](http://www.johansontechnology.com/ipcsoldering-profile)

## Antenna layout and tuning techniques

[www.johansontechnology.com/tuning](http://www.johansontechnology.com/tuning)

## Antenna layout review, tuning, and characterization services

[www.johansontechnology.com/ipc-antenna-services](http://www.johansontechnology.com/ipc-antenna-services)

## MSL Info

[www.johansontechnology.com/msl-rating](http://www.johansontechnology.com/msl-rating)

## Recommended Storage Condition and Max Shelf Life

[www.johansontechnology.com/recommended-storage-conditions](http://www.johansontechnology.com/recommended-storage-conditions)

## Packaging information

[www.johansontechnology.com/tape-reel-packaging](http://www.johansontechnology.com/tape-reel-packaging)

## Terminal Pad Composition

100% Tin (Sn)

Would you like us to review your layout for free? Need an embedded antenna recommendation for your application?

Contact us at:

[www.johansontechnology.com/ask-a-question](http://www.johansontechnology.com/ask-a-question)

Johanson Technology, Inc. reserves the right to make design changes without notice.

All sales are subject to Johanson Technology, Inc. terms and conditions.



[www.johansontechnology.com](http://www.johansontechnology.com)  
4001 Calle Tecate • Camarillo, CA 93012 • TEL 805.389.1166 FAX 805.389.1821

Ver. 1.0

2018 Johanson Technology, Inc. All Rights Reserved

Компания «Океан Электроники» предлагает заключение долгосрочных отношений при поставках импортных электронных компонентов на взаимовыгодных условиях!

Наши преимущества:

- Поставка оригинальных импортных электронных компонентов напрямую с производств Америки, Европы и Азии, а так же с крупнейших складов мира;
- Широкая линейка поставок активных и пассивных импортных электронных компонентов (более 30 млн. наименований);
- Поставка сложных, дефицитных, либо снятых с производства позиций;
- Оперативные сроки поставки под заказ (от 5 рабочих дней);
- Экспресс доставка в любую точку России;
- Помощь Конструкторского Отдела и консультации квалифицированных инженеров;
- Техническая поддержка проекта, помощь в подборе аналогов, поставка прототипов;
- Поставка электронных компонентов под контролем ВП;
- Система менеджмента качества сертифицирована по Международному стандарту ISO 9001;
- При необходимости вся продукция военного и аэрокосмического назначения проходит испытания и сертификацию в лаборатории (по согласованию с заказчиком);
- Поставка специализированных компонентов военного и аэрокосмического уровня качества (Xilinx, Altera, Analog Devices, Intersil, Interpoint, Microsemi, Actel, Aeroflex, Peregrine, VPT, Syfer, Eurofarad, Texas Instruments, MS Kennedy, Miteq, Cobham, E2V, MA-COM, Hittite, Mini-Circuits, General Dynamics и др.);

Компания «Океан Электроники» является официальным дистрибьютором и эксклюзивным представителем в России одного из крупнейших производителей разъемов военного и аэрокосмического назначения «JONHON», а так же официальным дистрибьютором и эксклюзивным представителем в России производителя высокотехнологичных и надежных решений для передачи СВЧ сигналов «FORSTAR».



## JONHON

«JONHON» (основан в 1970 г.)

Разъемы специального, военного и аэрокосмического назначения:

(Применяются в военной, авиационной, аэрокосмической, морской, железнодорожной, горно- и нефтедобывающей отраслях промышленности)

«FORSTAR» (основан в 1998 г.)

ВЧ соединители, коаксиальные кабели, кабельные сборки и микроволновые компоненты:

(Применяются в телекоммуникациях гражданского и специального назначения, в средствах связи, РЛС, а так же военной, авиационной и аэрокосмической отраслях промышленности).



Телефон: 8 (812) 309-75-97 (многоканальный)

Факс: 8 (812) 320-03-32

Электронная почта: [ocean@oceanchips.ru](mailto:ocean@oceanchips.ru)

Web: <http://oceanchips.ru/>

Адрес: 198099, г. Санкт-Петербург, ул. Калинина, д. 2, корп. 4, лит. А