

RF LDMOS Wideband Integrated Power Amplifiers

The avionics AFIC10275N is a 2-stage RFIC designed for transponder applications operating from 978 to 1090 MHz. These devices are suitable for use in pulse applications, including Mode S transponders used for ADS-B.

Narrowband Performance: (50 Vdc, T_A = 25°C)

Frequency (MHz)	Signal Type	P _{out} (W)	G _{ps} (dB)	2nd Stage Eff. (%)
1090 ⁽¹⁾	Pulse (128 μsec, 10% Duty Cycle)	250 Peak	32.1	61.4

Typical Wideband Performance (50 Vdc, T_A = 25°C)

Frequency (MHz) ⁽²⁾	Signal Type	P _{out} (W)	G _{ps} (dB)	2nd Stage Eff. (%)
978	Pulse (128 μsec, 10% Duty Cycle)	250 Peak	32.6	61.0
1030			32.5	59.1
1090			30.1	60.6

Load Mismatch/Ruggedness

Frequency (MHz)	Signal Type	VSWR	P _{in} (W)	Test Voltage	Result
1090 ⁽¹⁾	Pulse (128 μsec, 10% Duty Cycle)	> 10:1 at all Phase Angles	0.345 W Peak (3 dB Overdrive)	50	No Device Degradation

1. Measured in 1090 MHz narrowband test circuit.
2. Measured in 978 – 1090 MHz broadband reference circuit.

Features

- Characterized from 978 to 1090 MHz
- On-Chip Input (50 Ohm) and Interstage Matching
- Single Ended
- Integrated ESD Protection
- Low Thermal Resistance
- Integrated Quiescent Current Temperature Compensation with Enable/Disable Function⁽³⁾

Typical Applications

- Air Traffic Control Systems (ATC), Including Ground-based Secondary Radars
- Mode S Transponders, Including:
 - Traffic Alert and Collision Avoidance Systems (TCAS)
 - Automatic Dependent Surveillance-Broadcast In and Out (ADS-B) Using, e.g., 1090 Extended Squitter or Universal Access Transponder (UAT)
 - Mode S ELM Interrogators

3. Refer to [AN1977](#), *Quiescent Current Thermal Tracking Circuit in the RF Integrated Circuit Family*, and to [AN1987](#), *Quiescent Current Control for the RF Integrated Circuit Device Family*. Go to <http://www.freescale.com/rf> and search for AN1977 and AN1987.

AFIC10275N
AFIC10275GN

978–1090 MHz, 250 W PEAK, 50 V
AIRFAST RF LDMOS WIDEBAND
INTEGRATED POWER AMPLIFIERS



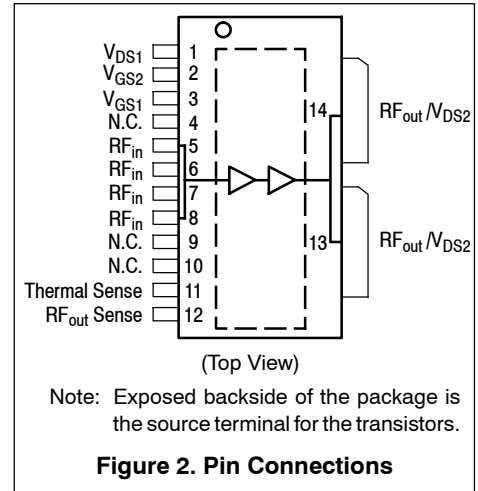
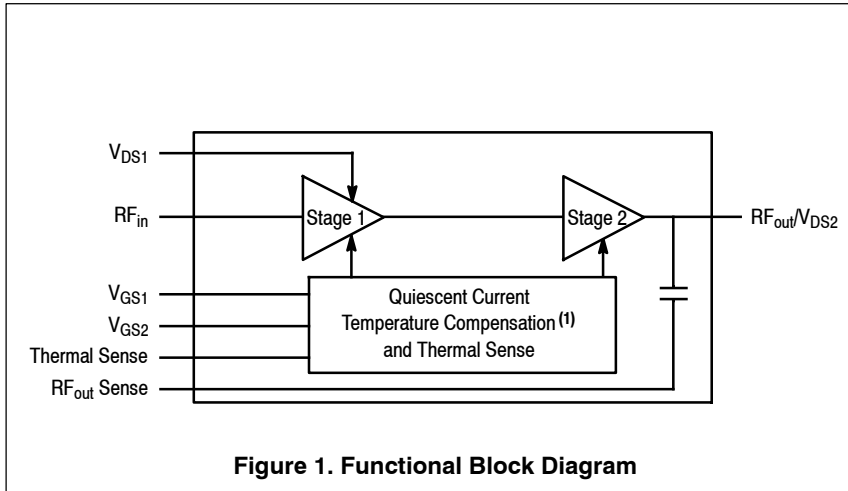

Table 1. Maximum Ratings

Rating	Symbol	Value	Unit
Drain-Source Voltage	V_{DS}	-0.5, +100	Vdc
Gate-Source Voltage	V_{GS}	-6, +10	Vdc
Operating Voltage	V_{DD}	50, +0	Vdc
Storage Temperature Range	T_{stg}	-65 to +150	°C
Case Operating Temperature Range	T_C	-40 to 150	°C
Operating Junction Temperature Range (2,3)	T_J	-40 to 225	°C
Input Power	P_{in}	25	dBm

Table 2. Thermal Characteristics

Characteristic	Symbol	Value (3,4)	Unit
Thermal Resistance, Junction to Case Case Temperature 81°C, 250 W Peak, 128 μ sec Pulse Width, 10% Duty Cycle, 1090 MHz Stage 1, 50 Vdc, I_{DQ1} = 80 mA Stage 2, 50 Vdc, I_{DQ2} = 150 mA	$Z_{\theta JC}$	1.1 0.15	°C/W

Table 3. ESD Protection Characteristics

Test Methodology	Class
Human Body Model (per JESD22-A114)	Class 2, passes 2500 V
Machine Model (per EIA/JESD22-A115)	Class A, passes 150 V
Charge Device Model (per JESD22-C101)	Class II, passes 200 V

Table 4. Moisture Sensitivity Level

Test Methodology	Rating	Package Peak Temperature	Unit
Per JESD22-A113, IPC/JEDEC J-STD-020	3	260	°C

1. Refer to [AN1977](#), *Quiescent Current Thermal Tracking Circuit in the RF Integrated Circuit Family*, and to [AN1987](#), *Quiescent Current Control for the RF Integrated Circuit Device Family*. Go to <http://www.freescale.com/rf> and search for AN1977 and AN1987.
2. Continuous use at maximum temperature will affect MTTF.
3. MTTF calculator available at <http://www.freescale.com/rf/calculators>.
4. Refer to [AN1955](#), *Thermal Measurement Methodology of RF Power Amplifiers*. Go to <http://www.freescale.com/rf> and search for AN1955.

Table 5. Electrical Characteristics ($T_A = 25^\circ\text{C}$ unless otherwise noted)

Characteristic	Symbol	Min	Typ	Max	Unit
Stage 1 - Off Characteristics					
Zero Gate Voltage Drain Leakage Current ($V_{DS} = 100\text{ Vdc}$, $V_{GS} = 0\text{ Vdc}$)	I_{DSS}	—	—	10	$\mu\text{A dc}$
Zero Gate Voltage Drain Leakage Current ($V_{DS} = 55\text{ Vdc}$, $V_{GS} = 0\text{ Vdc}$)	I_{DSS}	—	—	1	$\mu\text{A dc}$
Gate-Source Leakage Current ($V_{GS} = 1.5\text{ Vdc}$, $V_{DS} = 0\text{ Vdc}$)	I_{GSS}	—	—	1	$\mu\text{A dc}$

Stage 1 - On Characteristics

Gate Threshold Voltage ($V_{DS} = 10\text{ Vdc}$, $I_D = 52\ \mu\text{A dc}$)	$V_{GS(th)}$	1.3	1.8	2.3	Vdc
Fixture Gate Quiescent Voltage ($V_{DD} = 50\text{ Vdc}$, $I_{DQ1} = 80\text{ mA dc}$, Measured in Functional Test)	$V_{GG(Q)}$	6.0	7.0	8.0	Vdc

Stage 2 - Off Characteristics

Zero Gate Voltage Drain Leakage Current ($V_{DS} = 100\text{ Vdc}$, $V_{GS} = 0\text{ Vdc}$)	I_{DSS}	—	—	10	$\mu\text{A dc}$
Zero Gate Voltage Drain Leakage Current ($V_{DS} = 55\text{ Vdc}$, $V_{GS} = 0\text{ Vdc}$)	I_{DSS}	—	—	1	$\mu\text{A dc}$
Gate-Source Leakage Current ($V_{GS} = 1.5\text{ Vdc}$, $V_{DS} = 0\text{ Vdc}$)	I_{GSS}	—	—	1	$\mu\text{A dc}$

Stage 2 - On Characteristics

Gate Threshold Voltage ($V_{DS} = 10\text{ Vdc}$, $I_D = 528\ \mu\text{A dc}$)	$V_{GS(th)}$	1.3	1.8	2.3	Vdc
Fixture Gate Quiescent Voltage ($V_{DD} = 50\text{ Vdc}$, $I_{DQ2} = 150\text{ mA dc}$, Measured in Functional Test)	$V_{GG(Q)}$	2.2	2.7	3.2	Vdc
Drain-Source On-Voltage ($V_{GS} = 10\text{ Vdc}$, $I_D = 1.6\text{ A dc}$)	$V_{DS(on)}$	—	0.25	—	Vdc

Functional Tests ^(1,2) (In Freescale Test Fixture, 50 ohm system) $V_{DD} = 50\text{ Vdc}$, $I_{DQ1} = 80\text{ mA}$, $I_{DQ2} = 150\text{ mA}$, $P_{out} = 250\text{ W Peak}$ (25 W Avg.), $f = 1090\text{ MHz}$, 128 μsec Pulse Width, 10% Duty Cycle

Power Gain	G_{ps}	30.5	32.1	34.0	dB
2nd Stage Drain Efficiency	η_D	57.0	61.4	—	%

Load Mismatch/Ruggedness (In Freescale Test Fixture, 50 ohm system) $I_{DQ1} = 80\text{ mA}$, $I_{DQ2} = 150\text{ mA}$

Frequency (MHz)	Signal Type	VSWR	P_{in} (W)	Test Voltage, V_{DD}	Result
1090	Pulse (128 μsec , 10% Duty Cycle)	> 10:1 at all Phase Angles	0.345 W Peak (3 dB Overdrive)	50	No Device Degradation

Table 6. Ordering Information

Device	Tape and Reel Information	Package
AFIC10275NR1	R1 Suffix = 500 Units, 44 mm Tape Width, 13-inch Reel	TO-270WB-14
AFIC10275GNR1		TO-270WBG-14

- Part internally input matched.
- Measurements made with device in straight lead configuration before any lead forming operation is applied. Lead forming is used for gull wing (GN) parts.

TYPICAL CHARACTERISTICS

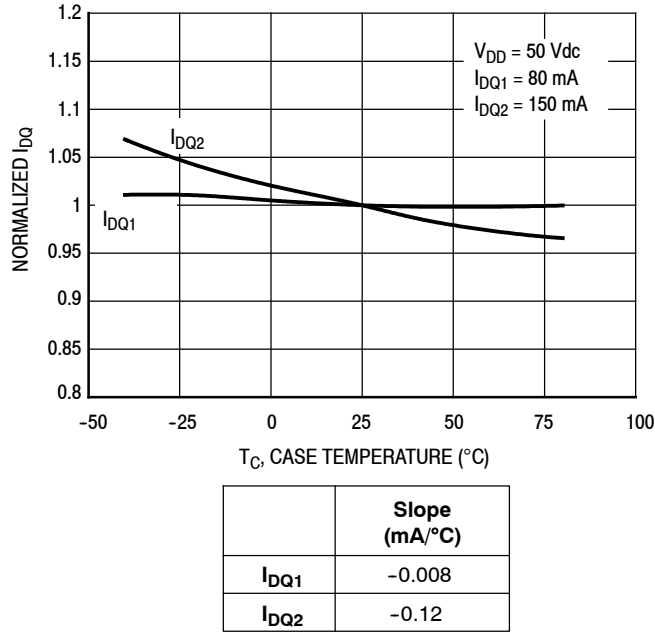
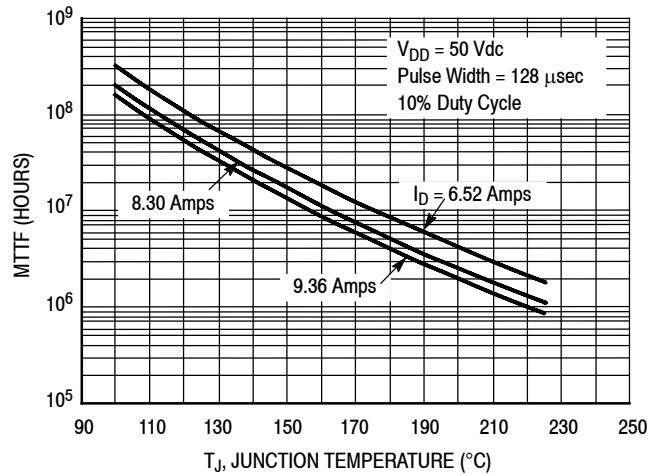

Figure 3. Normalized I_{DQ} versus Case Temperature



Note: MTTF value represents the total cumulative operating time under indicated test conditions.

MTTF calculator available at: <http://www.freescale.com/rf/calculators>

Figure 4. MTTF versus Junction Temperature - Pulse

978–1090 MHz BROADBAND REFERENCE CIRCUIT — 1.97" x 2.76" (5.0 cm x 7.0 cm)

Table 7. 978–1090 MHz Broadband Performance (In Freescale Reference Circuit, 50 ohm system)
 $V_{DD} = 50$ Vdc, $I_{DQ1} = 80$ mA, $I_{DQ2} = 150$ mA, $P_{out} = 250$ W Peak, 128 μ sec Pulse Width, 10% Duty Cycle

Frequency (MHz)	G_{ps} (dB)	2nd Stage Eff. (%)	Signal Type	P_{out} (W)
978	32.6	61.0	Pulse	250
1030	32.5	59.1	Pulse	250
1090	30.1	60.6	Pulse	250

Note: For additional information on the 978–1090 broadband reference circuit, contact your local Freescale sales office or Freescale authorized distributor.

978–1090 MHz BROADBAND REFERENCE CIRCUIT

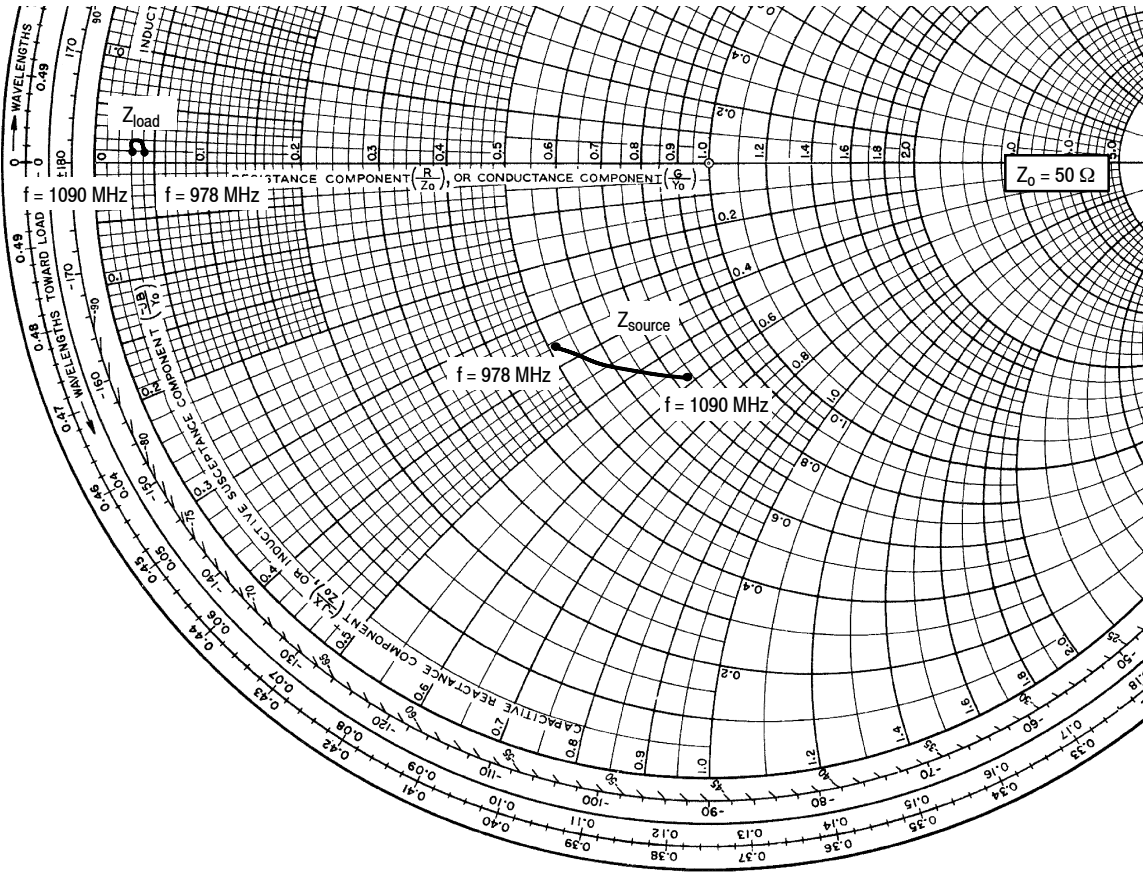

f MHz	Z _{source} Ω	Z _{load} Ω
978	26.0 - j18	2.2 + j0.05
1030	30.0 - j23	1.5 + j0.90
1090	36.7 - j29	1.3 + j0.60

Z_{source} = Test circuit input impedance as measured from gate to ground.

Z_{load} = Test circuit impedance as measured from drain to ground.

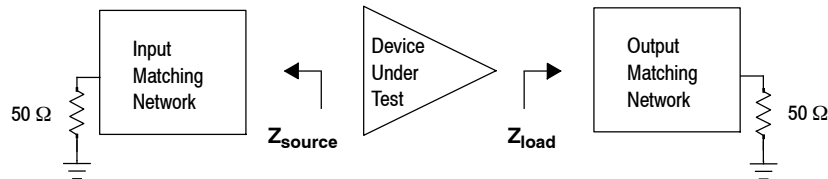
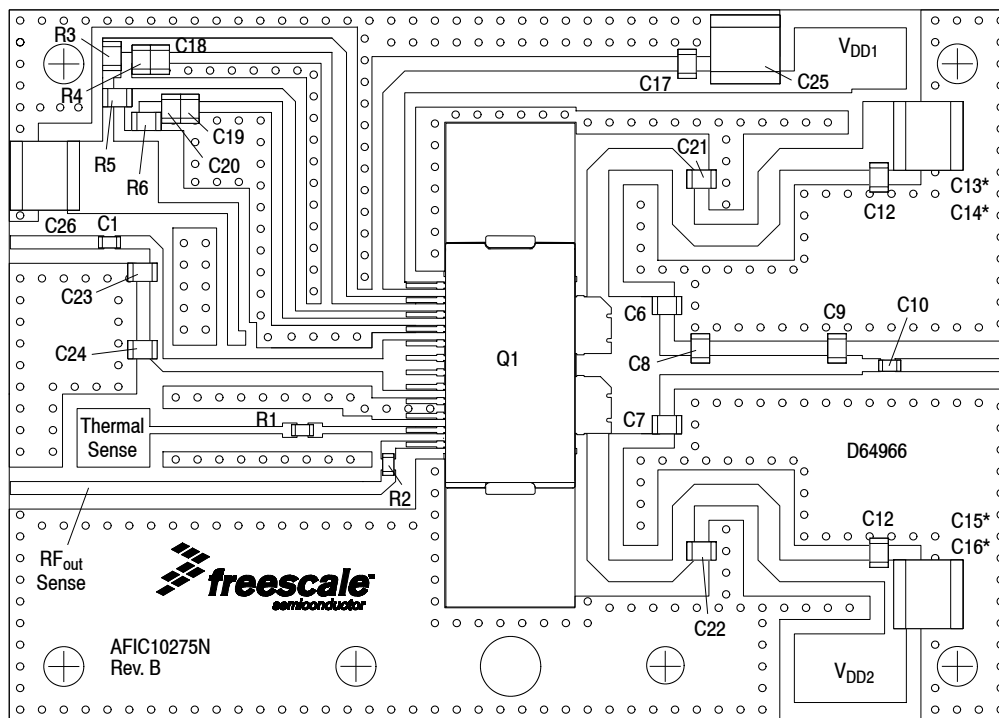

Figure 5. Broadband Series Equivalent Source and Load Impedance — 978–1090 MHz

1090 MHz REFERENCE CIRCUIT — 1.97" x 2.76" (5.0 cm x 7.0 cm)



* Stacked Capacitors

Note: Component numbers C2, C3, C4, and C5 are not used.

Figure 6. AFIC10275N Reference Component Layout — 1090 MHz

Table 8. AFIC10275N Reference Circuit Component Designations and Values — 1090 MHz

Part	Description	Part Number	Manufacturer
C1, C10	56 pF Chip Capacitors	ATC600F560JT250XT	ATC
C11, C12, C17, C18, C19	51 pF Chip Capacitors	ATC600F510JT250XT	ATC
C6, C7	10 pF Chip Capacitors	ATC600F100JT250XT	ATC
C8	6.8 pF Chip Capacitor	ATC600F6R8BT250XT	ATC
C9	2.4 pF Chip Capacitor	ATC600F2R4BT250XT	ATC
C13, C14, C15, C16, C25, C26	10 μ F Chip Capacitors	C5750X7S2A106M	TDK
C20	1 μ F Chip Capacitor	GRM21BR71H105KA12L	Murata
C21, C22	8.2 pF Chip Capacitors	ATC600F8R2BT250XT	ATC
C23	2.7 pF Chip Capacitor	ATC600F2R7BT250XT	ATC
C24	1.5 pF Chip Capacitor	ATC600F1R5BT250XT	ATC
R1	13.7 k Ω , 1/16 W Chip Resistor	RR0816P-1372-B-T5-14C	Susumu
R2	1.2 k Ω , 1/16 W Chip Resistor	RR0816P-122-B-T5	Susumu
Q1	RF Power LDMOS Transistor	AFIC10275NR1	Freescale
PCB	Taconic RF60A 0.025", $\epsilon_r = 6.15$	D64966	MTL

TYPICAL CHARACTERISTICS — 1090 MHz REFERENCE CIRCUIT

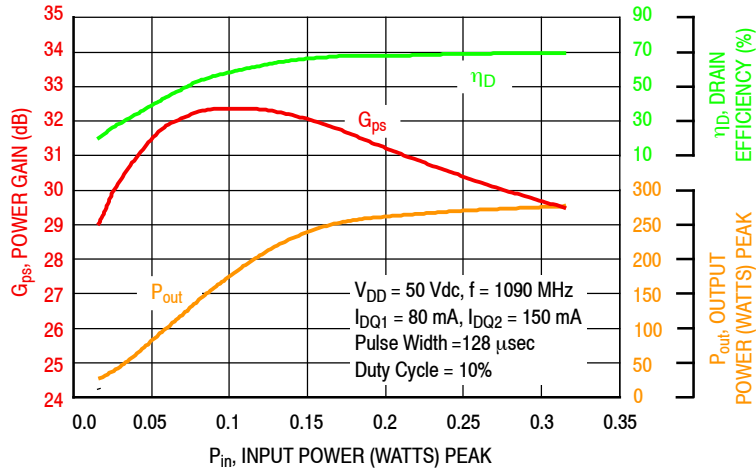

Figure 7. Power Gain, Drain Efficiency and Output Power versus Input Power

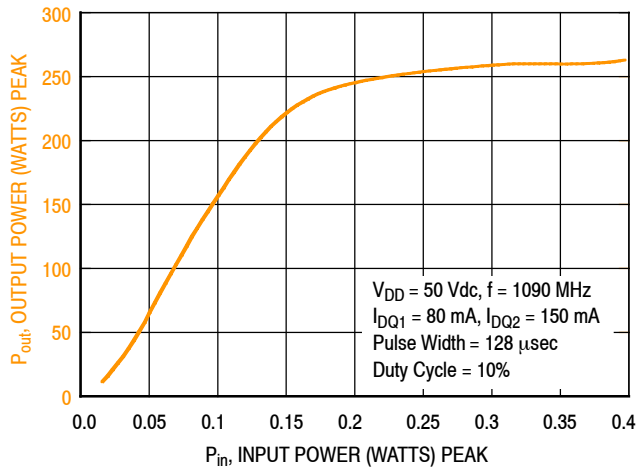

Figure 8. Output Power versus Input Power

f MHz	Z_{source} Ω	Z_{load} Ω
1090	$36.7 - j29$	$1.3 + j0.60$

Z_{source} = Test circuit input impedance as measured from gate to ground.

Z_{load} = Test circuit impedance as measured from drain to ground.

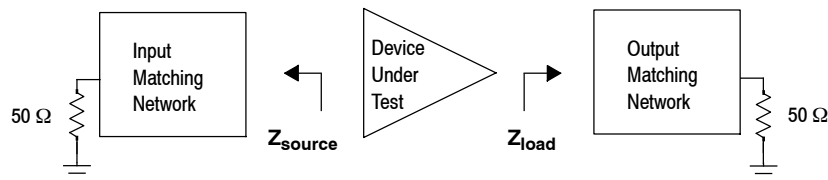

Figure 9. Series Equivalent Source and Load Impedance — 1090 MHz

1090 MHz NARROWBAND PRODUCTION TEST FIXTURE

Table 9. 1090 MHz Narrowband Performance ^(1,2) (In Freescale Test Fixture, 50 ohm system) $V_{DD} = 50$ Vdc, $I_{DQ1} = 80$ mA, $I_{DQ2} = 150$ mA, $P_{out} = 250$ W Peak (25 W Avg.), $f = 1090$ MHz, 128 μ sec Pulse Width, 10% Duty Cycle

Characteristic	Symbol	Min	Typ	Max	Unit
Power Gain	G_{ps}	30.5	32.1	34.0	dB
2nd Stage Drain Efficiency	η_D	57.0	61.4	—	%

1. Part internally input matched.
2. Measurements made with device in straight lead configuration before any lead forming operation is applied. Lead forming is used for gull wing (GN) parts.

1090 MHz NARROWBAND PRODUCTION TEST FIXTURE — 4" x 5" (10.2 cm x 12.7 cm)

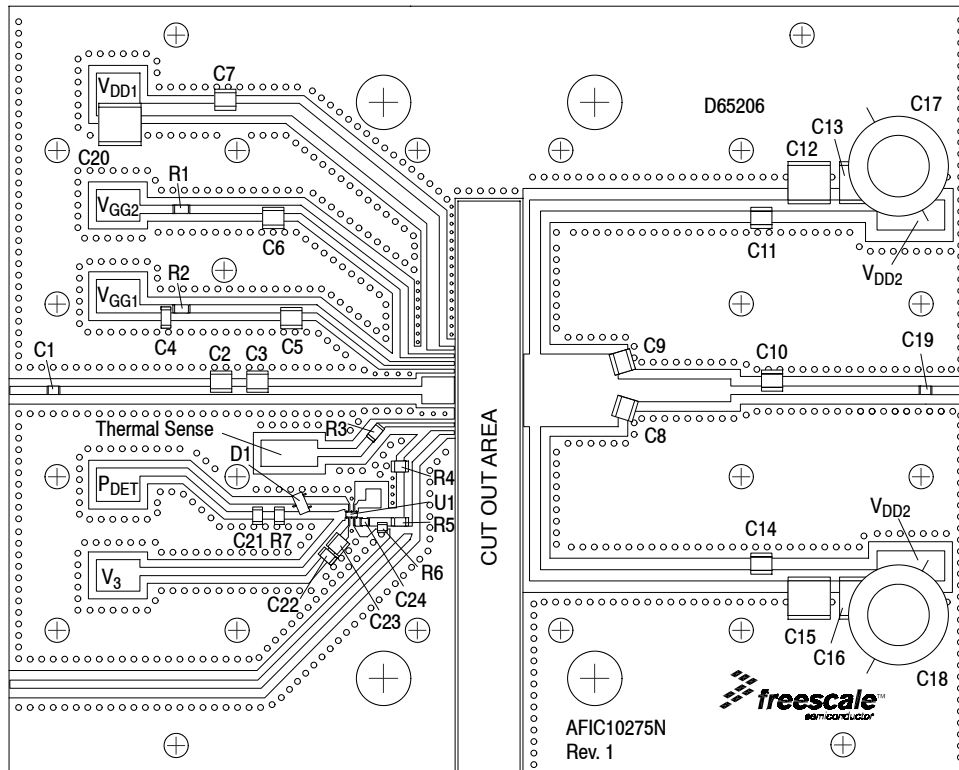

Figure 10. AFIC10275N Narrowband Test Circuit Component Layout — 1090 MHz

Table 10. AFIC10275N Narrowband Test Circuit Component Designations and Values — 1090 MHz

Part	Description	Part Number	Manufacturer
C1	47 pF Chip Capacitor	ATC600F470JT250XT	ATC
C2	2.7 pF Chip Capacitor	ATC100B2R7CT500XT	ATC
C3	2.0 pF Chip Capacitor	ATC100B2R0BW500XT	ATC
C4	1 μ F Chip Capacitor	GRM31MR71H105KA88L	Murata
C5, C6, C7, C11, C14	43 pF Chip Capacitors	ATC100B430JT500XT	ATC
C8, C9	10 pF Chip Capacitors	ATC100B100JT500XT	ATC
C10	4.7 pF Chip Capacitor	ATC100B4R7CT500XT	ATC
C12, C13, C15, C16, C20	10 μ F Chip Capacitors	C5750X752A106M230KB	TDK
C17, C18	220 μ F, 100 V Electrolytic Capacitors	MCGPR100V227M16X26-RH	Multicomp
C19	30 pF Chip Capacitor	ATC600F300JT250XT	ATC
C21	10 nF Chip Capacitor	C0805C103J5RAC-TU	Kemet
C22	0.1 μ F Chip Capacitor	C1206C104K1RAC-TU	Kemet
C23	47 pF Chip Capacitor	ATC800B470JT500XT	ATC
C24	1000 pF Chip Capacitor	C2012X7R2E102K085AA	TDK
D1	Diode Schottky RF SGL 70 V SOT-23	HSMS-2800-TR1G	Avago Technologies
R1	2.2 k Ω , 1/8 W Chip Resistor	CRCW08052K20JNEA	Vishay
R2	0 Ω , 1 A Chip Resistor	CWCR08050000Z0EA	Vishay
R3	1 k Ω , 1/10 W Chip Resistor	RR1220P-102-D	Susumu
R4	50 Ω , 10 W Chip Resistor	060120A25X50-2	Anaren
R5	15 k Ω , 1/10 W Chip Resistor	RR1220P-153-D	Susumu
R6	51 Ω , 1/8 W Chip Resistor	RK73B2ATTD510J	KOA Speer
R7	470 k Ω , 1/4 W Chip Resistor	CRCW1206470KFKEA	Vishay
U1	IC Detector RF PWR 3GHZ SC70-6	LT5534ESC6#TRMPBF	Linear Technology
PCB	Rogers, RO4350B, 0.020", $\epsilon_r = 3.66$	D65206	MTL

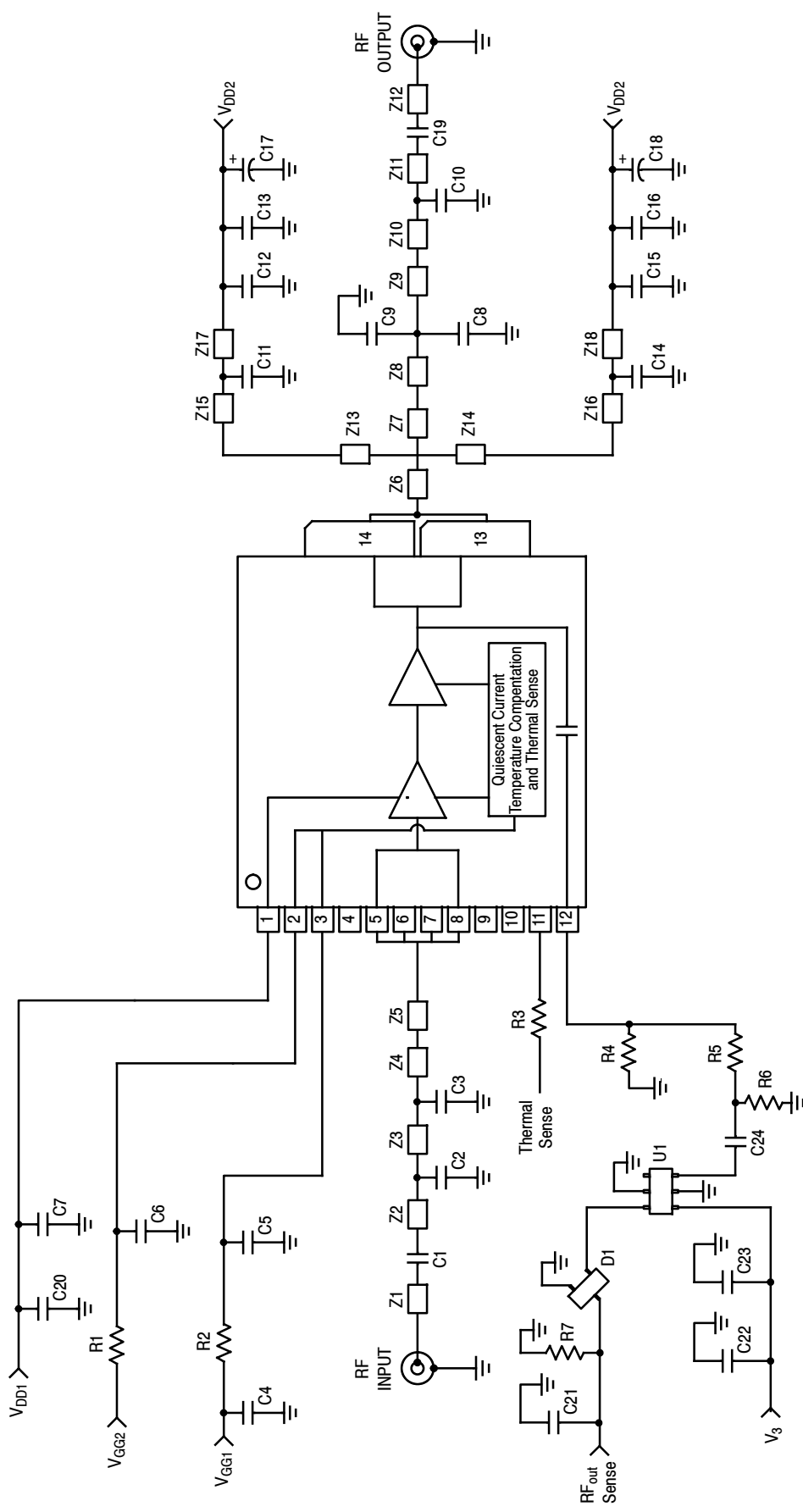

Figure 11. AFIC10275N Narrowband Test Circuit Schematic — 1090 MHz

Table 11. AFIC10275N Narrowband Test Circuit Microstrips — 1090 MHz

Microstrip	Description	Microstrip	Description
Z1	0.202" x 0.043" Microstrip	Z6	0.030" x 0.378" Microstrip
Z2	0.849" x 0.043" Microstrip	Z7	0.058" x 0.378" Microstrip
Z3	0.188" x 0.043" Microstrip	Z8	0.404" x 0.378" Microstrip
Z4	0.857" x 0.043" Microstrip	Z9	0.587" x 0.118" Microstrip
Z5	0.170" x 0.140" Microstrip	Z10	0.215" x 0.044" Microstrip
		Z11	0.774" x 0.044" Microstrip
		Z12	0.803" x 0.058" Microstrip
		Z13, Z14	0.025" x 0.485" Microstrip
		Z15,* Z16*	1.150" x 0.058" Microstrip
		Z17, Z18	0.249" x 0.058" Microstrip

* Line length include microstrip bends

TYPICAL CHARACTERISTICS — 1090 MHz NARROWBAND PRODUCTION TEST FIXTURE

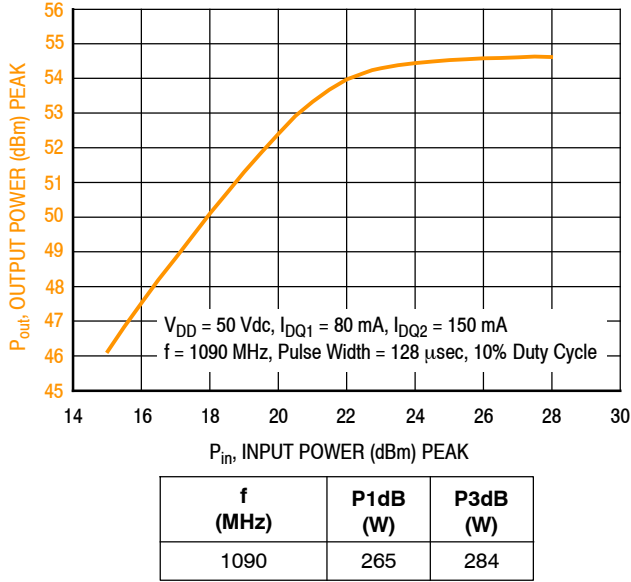

Figure 12. Output Power versus Input Power

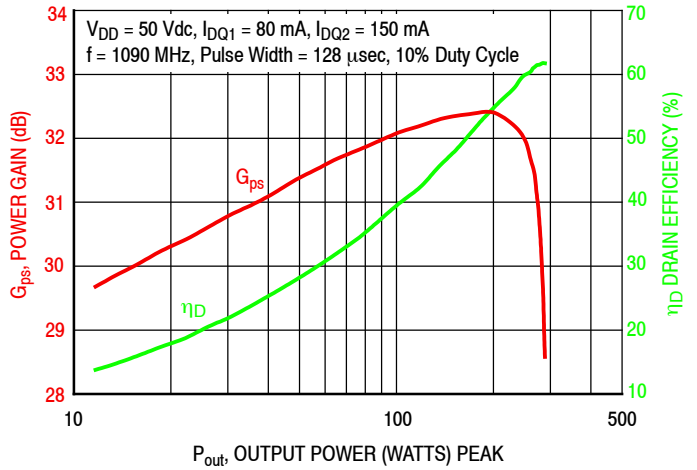

Figure 13. Power Gain and Drain Efficiency versus Output Power and Quiescent Current

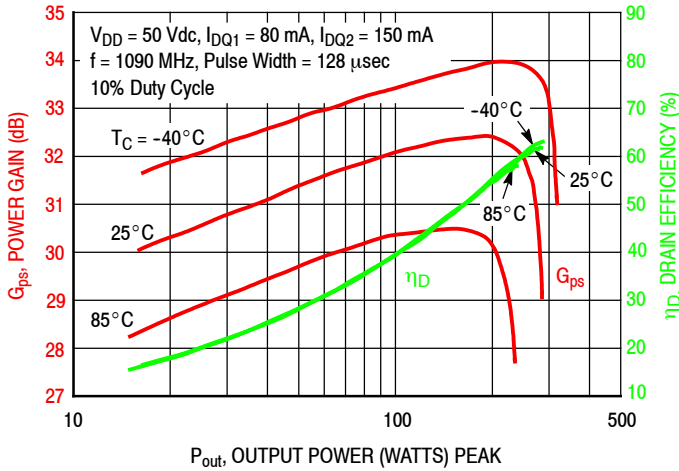

Figure 14. Power Gain and Drain Efficiency versus Output Power

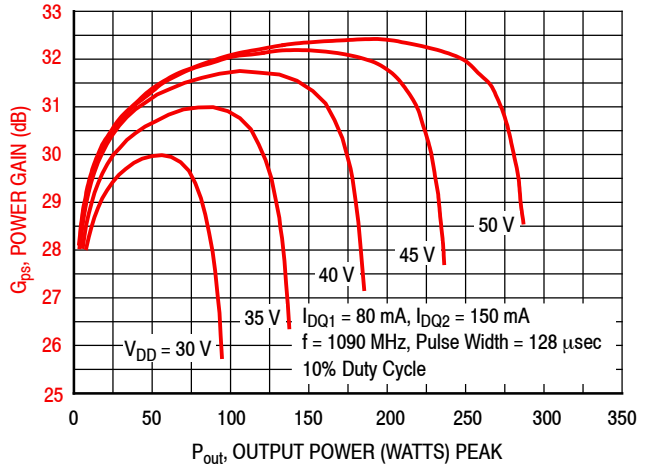

Figure 15. Power Gain versus Output Power and Drain-Source Voltage

1090 MHz NARROWBAND PRODUCTION TEST FIXTURE

f MHz	Z_{source} Ω	Z_{load} Ω
1090	$13.6 - j24.4$	$1.3 + j0.4$

Z_{source} = Test circuit impedance as measured from gate to ground.

Z_{load} = Test circuit impedance as measured from drain to ground.

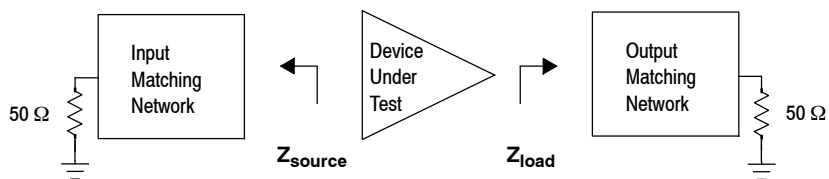
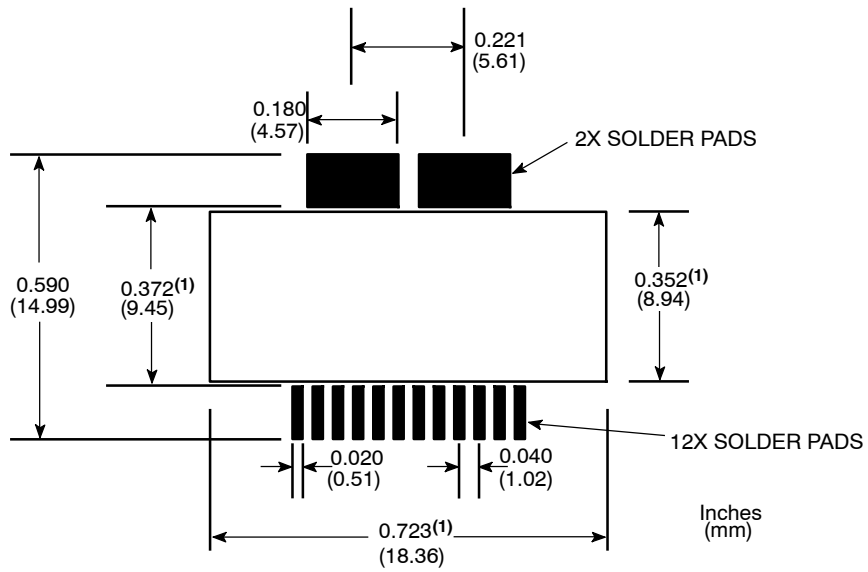

Figure 16. Narrowband Series Equivalent Source and Load Impedance — 1090 MHz



1. Slot dimensions are minimum dimensions and exclude milling tolerances.

Figure 17. PCB Pad Layout for TO-270WB-14

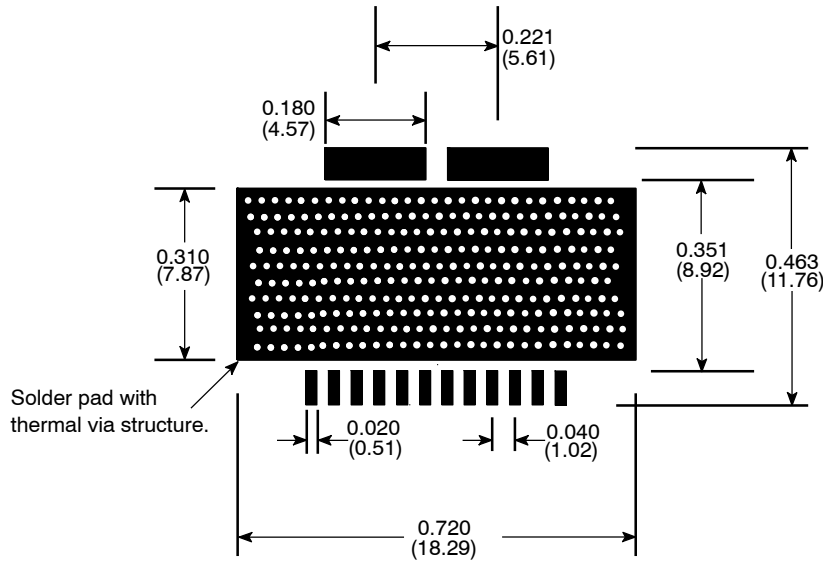
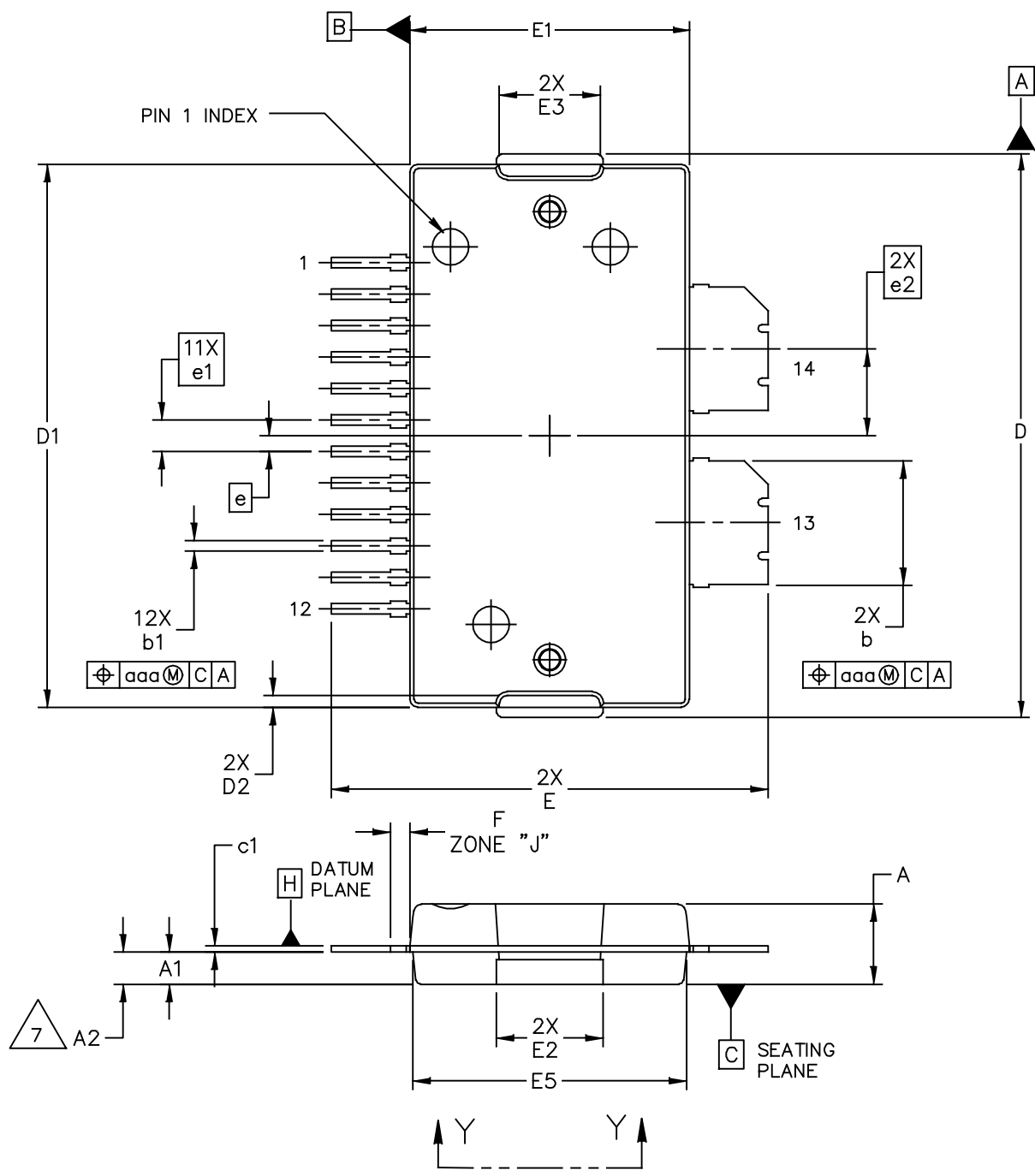
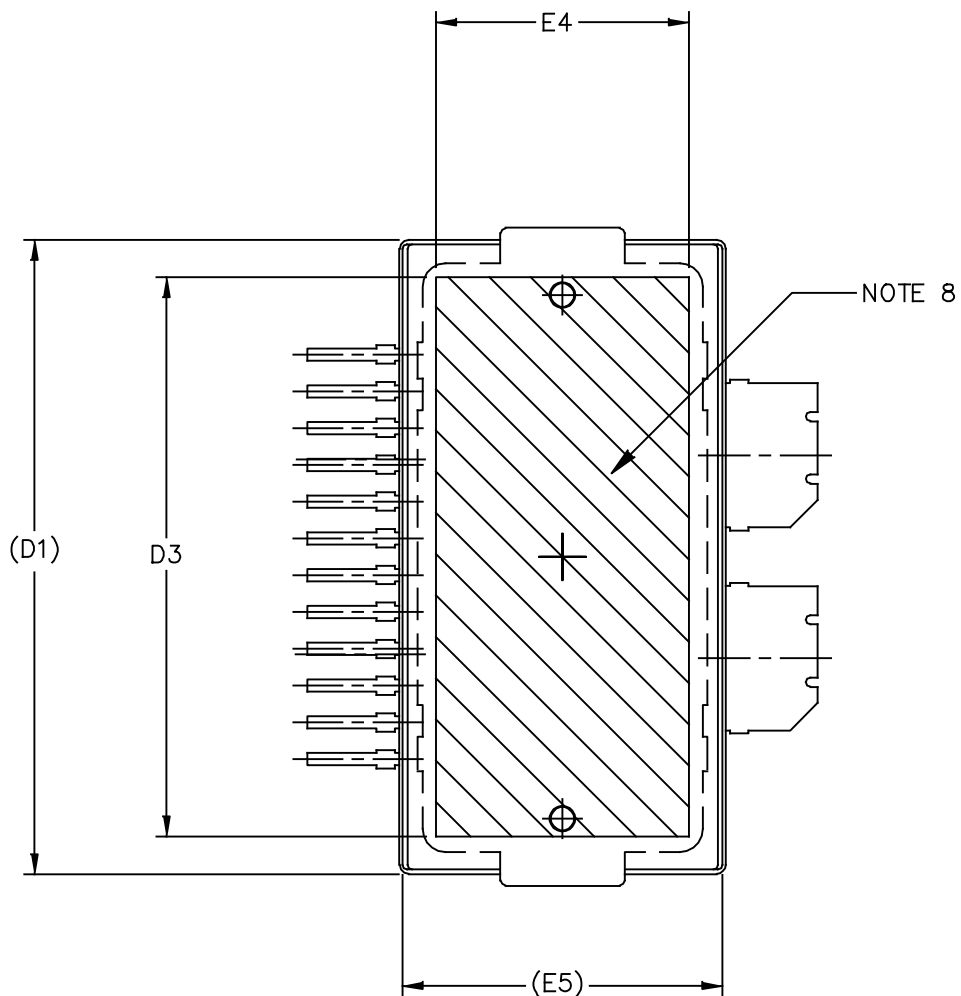

Figure 18. PCB Pad Layout for TO-270WBG-14

PACKAGE DIMENSIONS



© FREESCALE SEMICONDUCTOR, INC. ALL RIGHTS RESERVED.		MECHANICAL OUTLINE		PRINT VERSION NOT TO SCALE	
TITLE: TO-270 WIDE BODY 14 LEAD		DOCUMENT NO: 98ASA10650D		REV: A	
		CASE NUMBER: 1618-02		19 JUN 2007	
		STANDARD: NON-JEDEC			



VIEW Y-Y

© FREESCALE SEMICONDUCTOR, INC. ALL RIGHTS RESERVED.	MECHANICAL OUTLINE	PRINT VERSION NOT TO SCALE	
TITLE: TO-270 WIDE BODY 14 LEAD		DOCUMENT NO: 98ASA10650D	REV: A
		CASE NUMBER: 1618-02	19 JUN 2007
		STANDARD: NON-JEDEC	

NOTES:

1. CONTROLLING DIMENSION: INCH
2. INTERPRET DIMENSIONS AND TOLERANCES PER ASME Y14.5M-1994.
3. DATUM PLANE -H- IS LOCATED AT THE TOP OF LEAD AND IS COINCIDENT WITH THE LEAD WHERE THE LEAD EXITS THE PLASTIC BODY AT THE TOP OF THE PARTING LINE.
4. DIMENSIONS "D" AND "E1" DO NOT INCLUDE MOLD PROTRUSION. ALLOWABLE PROTRUSION IS .006 PER SIDE. DIMENSIONS "D" AND "E1" DO INCLUDE MOLD MISMATCH AND ARE DETERMINED AT DATUM PLANE -H-.
5. DIMENSIONS "b" AND "b1" DOES NOT INCLUDE DAMBAR PROTRUSION. ALLOWABLE DAMBAR PROTRUSION SHALL BE .005 TOTAL IN EXCESS OF THE "b" AND "b1" DIMENSION AT MAXIMUM MATERIAL CONDITION.
6. DATUMS -A- AND -B- TO BE DETERMINED AT DATUM PLANE -H-.
7. DIMENSION A2 APPLIES WITHIN ZONE "J" ONLY.
8. HATCHING REPRESENTS THE EXPOSED AREA OF THE HEAT SLUG.

DIM	INCH		MILLIMETER		DIM	INCH		MILLIMETER	
	MIN	MAX	MIN	MAX		MIN	MAX	MIN	MAX
A	.100	.104	2.54	2.64	F	.025 BSC		0.64 BSC	
A1	.039	.043	0.99	1.09	b	.154	.160	3.91	4.06
A2	.040	.042	1.02	1.07	b1	.010	.016	0.25	0.41
D	.712	.720	18.08	18.29	c1	.007	.011	.18	.28
D1	.688	.692	17.48	17.58	e	.020 BSC		0.51 BSC	
D2	.011	.019	0.28	0.48	e1	.040 BSC		1.02 BSC	
D3	.600	---	15.24	---	e2	.1105 BSC		2.807 BSC	
E	.551	.559	14	14.2					
E1	.353	.357	8.97	9.07	aaa	.004		.10	
E2	.132	.140	3.35	3.56					
E3	.124	.132	3.15	3.35					
E4	.270	---	6.86	---					
E5	.346	.350	8.79	8.89					
© FREESCALE SEMICONDUCTOR, INC. ALL RIGHTS RESERVED.			MECHANICAL OUTLINE			PRINT VERSION NOT TO SCALE			
TITLE: TO-270 WIDE BODY 14 LEAD					DOCUMENT NO: 98ASA10650D			REV: A	
					CASE NUMBER: 1618-02			19 JUN 2007	
					STANDARD: NON-JEDEC				

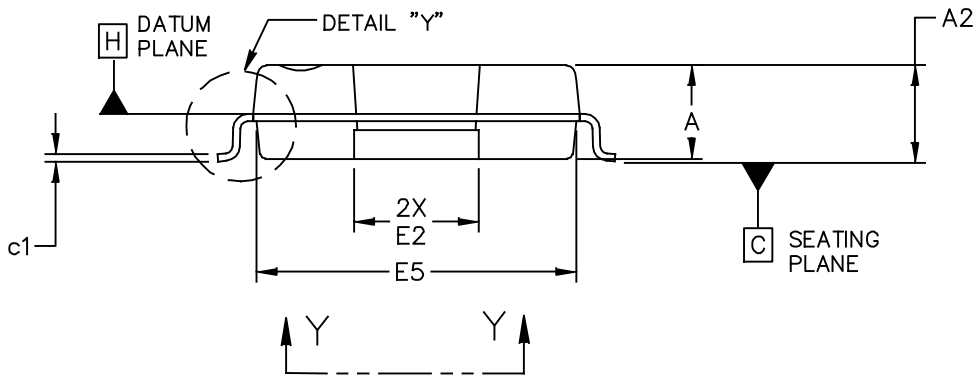
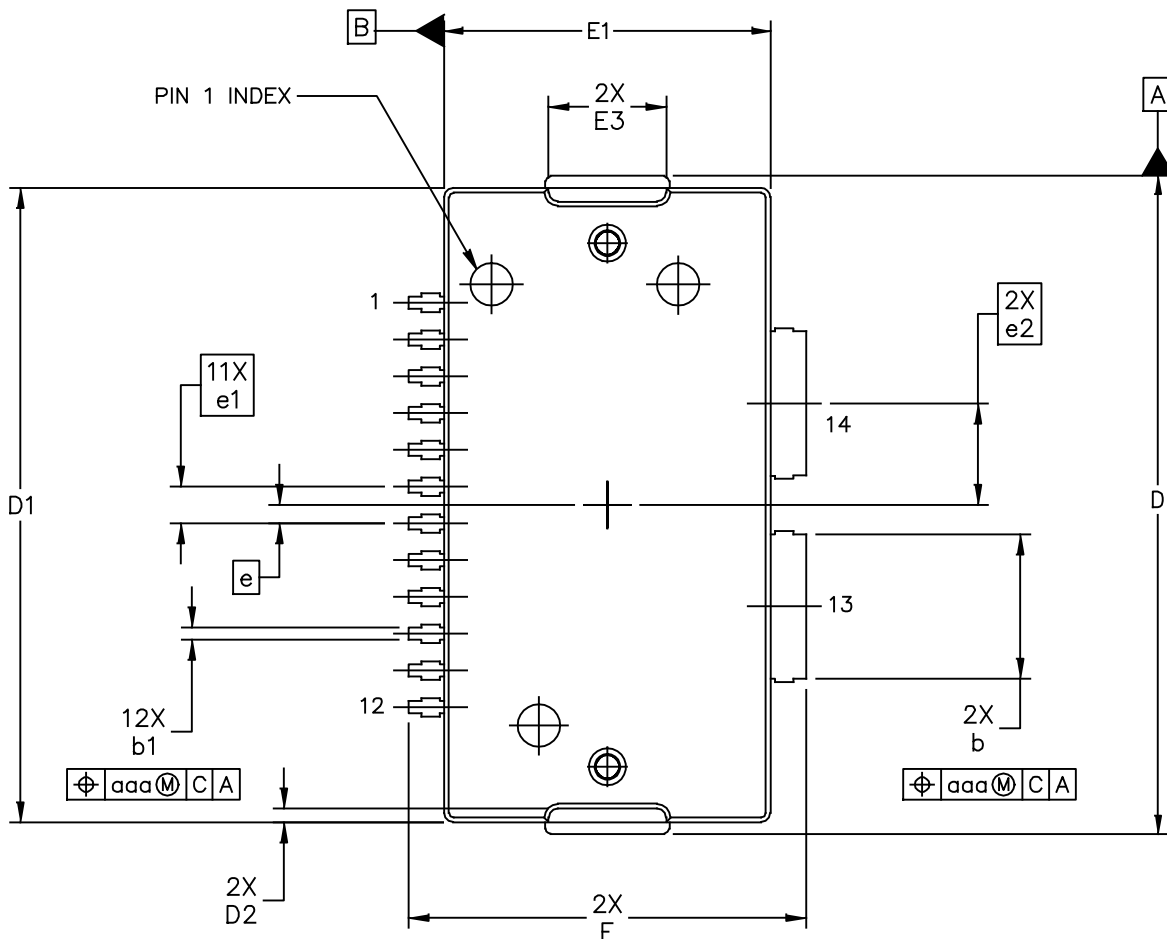

© FREESCALE SEMICONDUCTOR, INC. ALL RIGHTS RESERVED.	MECHANICAL OUTLINE	PRINT VERSION NOT TO SCALE	
TITLE: TO-270 WIDE BODY 14 LEAD GULL WING	DOCUMENT NO: 98ASA10653D	REV: A	
	CASE NUMBER: 1621-02	19 JUN 2007	
	STANDARD: NON-JEDEC		

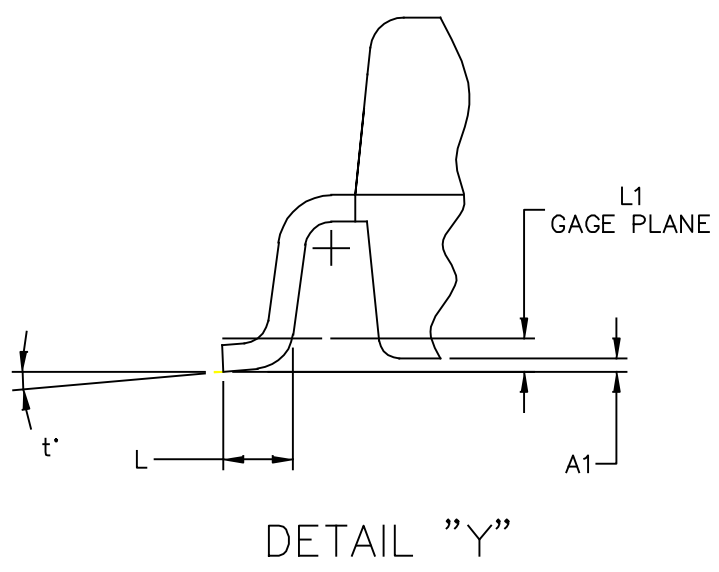
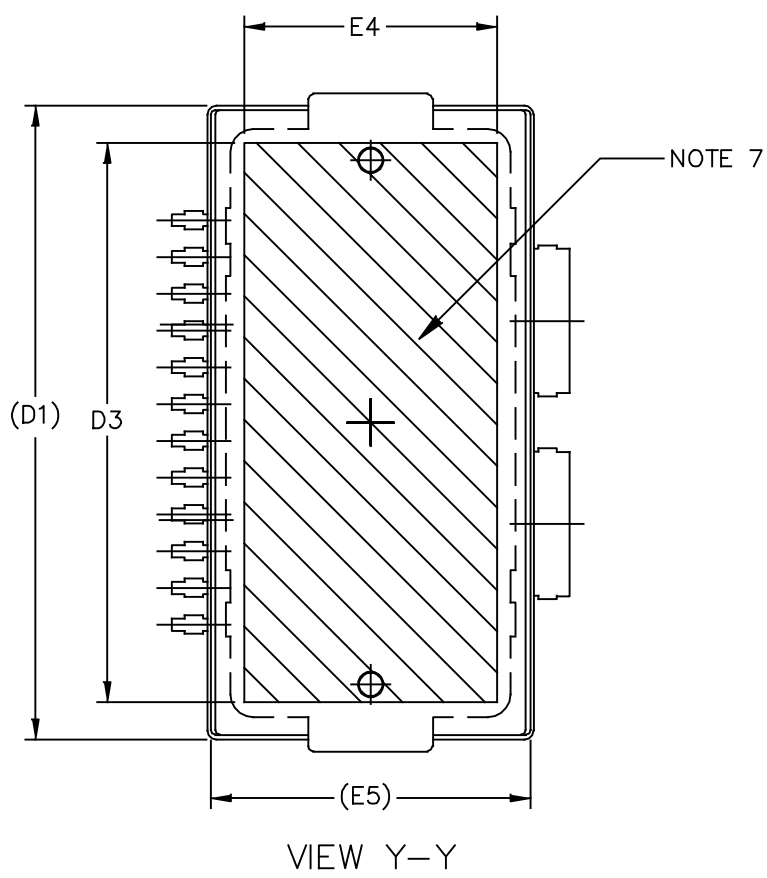

© FREESCALE SEMICONDUCTOR, INC. ALL RIGHTS RESERVED.	MECHANICAL OUTLINE	PRINT VERSION NOT TO SCALE	
TITLE: TO-270 WIDE BODY 14 LEAD GULL WING	DOCUMENT NO: 98ASA10653D	REV: A	
	CASE NUMBER: 1621-02	19 JUN 2007	
	STANDARD: NON-JEDEC		

NOTES:

1. CONTROLLING DIMENSION: INCH
2. INTERPRET DIMENSIONS AND TOLERANCES PER ASME Y14.5M-1994.
3. DATUM PLANE -H- IS LOCATED AT THE TOP OF LEAD AND IS COINCIDENT WITH THE LEAD WHERE THE LEAD EXITS THE PLASTIC BODY AT THE TOP OF THE PARTING LINE.
4. DIMENSIONS "D" AND "E1" DO NOT INCLUDE MOLD PROTRUSION. ALLOWABLE PROTRUSION IS .006 PER SIDE. DIMENSIONS "D" AND "E1" DO INCLUDE MOLD MISMATCH AND ARE DETERMINED AT DATUM PLANE -H-.
5. DIMENSIONS "b" AND "b1" DOES NOT INCLUDE DAMBAR PROTRUSION. ALLOWABLE DAMBAR PROTRUSION SHALL BE .005 TOTAL IN EXCESS OF THE "b" AND "b1" DIMENSION AT MAXIMUM MATERIAL CONDITION.
6. DATUMS -A- AND -B- TO BE DETERMINED AT DATUM PLANE -H-.
7. HATCHING REPRESENTS THE EXPOSED AREA OF THE HEAT SLUG.

DIM	INCH		MILLIMETER		DIM	INCH		MILLIMETER	
	MIN	MAX	MIN	MAX		MIN	MAX	MIN	MAX
A	.100	.104	2.54	2.64	L	.018	.024	0.46	0.61
A1	.001	.004	0.02	0.10	L1	.010 BSC		0.25 BSC	
A2	.099	.110	2.51	2.79	b	.154	.160	3.91	4.06
D	.712	.720	18.08	18.29	b1	.010	.016	0.25	0.41
D1	.688	.692	17.48	17.58	c1	.007	.011	.18	.28
D2	.011	.019	0.28	0.48	e	.020 BSC		0.51 BSC	
D3	.600	---	15.24	---	e1	.040 BSC		1.02 BSC	
E	.429	.437	10.9	11.1	e2	.1105 BSC		2.807 BSC	
E1	.353	.357	8.97	9.07	t	2'	8'	2'	8'
E2	.132	.140	3.35	3.56					
E3	.124	.132	3.15	3.35	aaa	.004		.10	
E4	.270	---	6.86	---					
E5	.346	.350	8.79	8.89					
© FREESCALE SEMICONDUCTOR, INC. ALL RIGHTS RESERVED.			MECHANICAL OUTLINE			PRINT VERSION NOT TO SCALE			
TITLE: TO-270 WIDE BODY 14 LEAD GULL WING					DOCUMENT NO: 98ASA10653D			REV: A	
					CASE NUMBER: 1621-02			19 JUN 2007	
					STANDARD: NON-JEDEC				

Refer to the following resources to aid your design process.

Application Notes

- AN1907: Solder Reflow Attach Method for High Power RF Devices in Plastic Packages
- AN1955: Thermal Measurement Methodology of RF Power Amplifiers
- AN1977: Quiescent Current Thermal Tracking Circuit in the RF Integrated Circuit Family
- AN1987: Quiescent Current Control for the RF Integrated Circuit Device Family

Engineering Bulletins

- EB212: Using Data Sheet Impedances for RF LDMOS Devices

White Paper

- RFPLASTICWP: Designing with Plastic RF Power Transistors

Software

- Electromigration MTTF Calculator
- RF High Power Model

Development Tools

- Printed Circuit Boards

To Download Resources Specific to a Given Part Number:

1. Go to <http://www.freescale.com/rf>
2. Search by part number
3. Click part number link
4. Choose the desired resource from the drop down menu

REVISION HISTORY

The following table summarizes revisions to this document.

Revision	Date	Description
0	Apr. 2015	• Initial Release of Data Sheet

How to Reach Us:

Home Page:
freescale.com

Web Support:
freescale.com/support

Information in this document is provided solely to enable system and software implementers to use Freescale products. There are no express or implied copyright licenses granted hereunder to design or fabricate any integrated circuits based on the information in this document.

Freescale reserves the right to make changes without further notice to any products herein. Freescale makes no warranty, representation, or guarantee regarding the suitability of its products for any particular purpose, nor does Freescale assume any liability arising out of the application or use of any product or circuit, and specifically disclaims any and all liability, including without limitation consequential or incidental damages. "Typical" parameters that may be provided in Freescale data sheets and/or specifications can and do vary in different applications, and actual performance may vary over time. All operating parameters, including "typicals," must be validated for each customer application by customer's technical experts. Freescale does not convey any license under its patent rights nor the rights of others. Freescale sells products pursuant to standard terms and conditions of sale, which can be found at the following address: freescale.com/SalesTermsandConditions.

Freescale and the Freescale logo are trademarks of Freescale Semiconductor, Inc., Reg. U.S. Pat. & Tm. Off. Airfast is a trademark of Freescale Semiconductor, Inc. All other product or service names are the property of their respective owners.

© 2015 Freescale Semiconductor, Inc.

Компания «Океан Электроники» предлагает заключение долгосрочных отношений при поставках импортных электронных компонентов на взаимовыгодных условиях!

Наши преимущества:

- Поставка оригинальных импортных электронных компонентов напрямую с производств Америки, Европы и Азии, а так же с крупнейших складов мира;
- Широкая линейка поставок активных и пассивных импортных электронных компонентов (более 30 млн. наименований);
- Поставка сложных, дефицитных, либо снятых с производства позиций;
- Оперативные сроки поставки под заказ (от 5 рабочих дней);
- Экспресс доставка в любую точку России;
- Помощь Конструкторского Отдела и консультации квалифицированных инженеров;
- Техническая поддержка проекта, помощь в подборе аналогов, поставка прототипов;
- Поставка электронных компонентов под контролем ВП;
- Система менеджмента качества сертифицирована по Международному стандарту ISO 9001;
- При необходимости вся продукция военного и аэрокосмического назначения проходит испытания и сертификацию в лаборатории (по согласованию с заказчиком);
- Поставка специализированных компонентов военного и аэрокосмического уровня качества (Xilinx, Altera, Analog Devices, Intersil, Interpoint, Microsemi, Actel, Aeroflex, Peregrine, VPT, Syfer, Eurofarad, Texas Instruments, MS Kennedy, Miteq, Cobham, E2V, MA-COM, Hittite, Mini-Circuits, General Dynamics и др.);

Компания «Океан Электроники» является официальным дистрибьютором и эксклюзивным представителем в России одного из крупнейших производителей разъемов военного и аэрокосмического назначения «JONHON», а так же официальным дистрибьютором и эксклюзивным представителем в России производителя высокотехнологичных и надежных решений для передачи СВЧ сигналов «FORSTAR».



JONHON

«JONHON» (основан в 1970 г.)

Разъемы специального, военного и аэрокосмического назначения:

(Применяются в военной, авиационной, аэрокосмической, морской, железнодорожной, горно- и нефтедобывающей отраслях промышленности)

«FORSTAR» (основан в 1998 г.)

ВЧ соединители, коаксиальные кабели, кабельные сборки и микроволновые компоненты:

(Применяются в телекоммуникациях гражданского и специального назначения, в средствах связи, РЛС, а так же военной, авиационной и аэрокосмической отраслях промышленности).



Телефон: 8 (812) 309-75-97 (многоканальный)

Факс: 8 (812) 320-03-32

Электронная почта: ocean@oceanchips.ru

Web: <http://oceanchips.ru/>

Адрес: 198099, г. Санкт-Петербург, ул. Калинина, д. 2, корп. 4, лит. А