

## High Precision Bulk Metal® Foil Surface Mount Voltage Divider, TCR Tracking of $< 0.5 \text{ ppm}/^\circ\text{C}$ , Tolerance Match of $0.01 \%$ and Stability of $\pm 0.005 \%$ (50 ppm)



### INTRODUCTION

Bulk Metal® Foil (BMF) technology out-performs all other resistor technologies available today for applications that require high precision and high stability.

This technology has been invented, patented and pioneered by Vishay Foil Resistors (VFR). Products based on this technology are the most suitable for a wide range of applications.

BMF technology allows the production of customer oriented products designed to satisfy challenging and specific technical requirements. Model DSM offers low TCR (both absolute and tracking), excellent load life stability, tight tolerance, excellent ratio stability, and low current noise, all in one package.

The DSM surface mount divider provides a matched pair of Bulk Metal Foil resistors in a small epoxy molded package. The electrical specification of this integrated construction offers improved performance and better real estate utilization over discrete resistors and matched pairs.

VFR's application engineering department is available to advise and make recommendations. For non-standard technical requirements and special applications, please contact [foil@vpgsensors.com](mailto:foil@vpgsensors.com).

### FEATURES

- Temperature coefficient of resistance (TCR):  
Absolute:  $2 \text{ ppm}/^\circ\text{C}$  typical  
( $-55^\circ\text{C}$  to  $+125^\circ\text{C}$ ,  $+25^\circ\text{C}$  ref.)  
Tracking:  $0.5 \text{ ppm}/^\circ\text{C}$  typical
- Tolerance: absolute:  $\pm 0.02 \%$ ; match:  $0.01 \%$
- Power rating: at  $70^\circ\text{C}$ : entire package:  $0.1 \text{ W}$   
each resistor:  $0.05 \text{ W}$
- Ratio stability:  $0.005 \%$  ( $0.05 \text{ W}$  at  $70^\circ\text{C}$ , 2000 h)
- Resistance range:  $100 \Omega$  to  $12 \text{ k}\Omega$  per resistor
- Large variety of resistance ratios: 1:120
- Bulk Metal Foil resistors are not restricted to standard values/ratios; specific "as required" values/ratios can be supplied at no extra cost or delivery (e.g. 1K234/2K345 vs. 1K/2K)
- Thermal stabilization time  $< 1 \text{ s}$  (nominal value achieved within 10 ppm of steady state value)
- Electrostatic discharge (ESD) at least to 25kV
- Short time overload:  $0.005 \%$
- Non inductive, non capacitive design
- Rise time:  $1 \text{ ns}$  effectively no ringing
- Current noise:  $< 0.010 \mu\text{V}_{\text{RMS}}/\text{V}$  of applied voltage ( $-40 \text{ dB}$ )
- Voltage coefficient:  $0.1 \text{ ppm}/\text{V}$
- Non inductive:  $0.08 \mu\text{H}$
- Non hot spot design
- Terminals: silver coated copper alloy (see Table 5)
- Compliant to RoHS directive 2002/95/EC
- Prototype quantities available in just 5 working days or sooner. For more information, please contact [foil@vpgsensors.com](mailto:foil@vpgsensors.com)
- For better performances, please see DSMZ datasheet (Z-Foil)



Available  
RoHS\*  
COMPLIANT

**FIGURE 1 - SCHEMATIC**

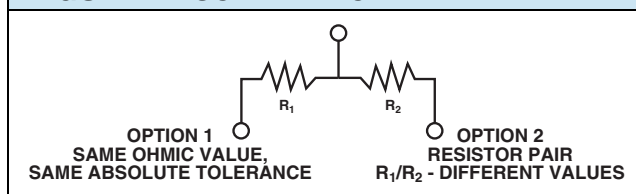
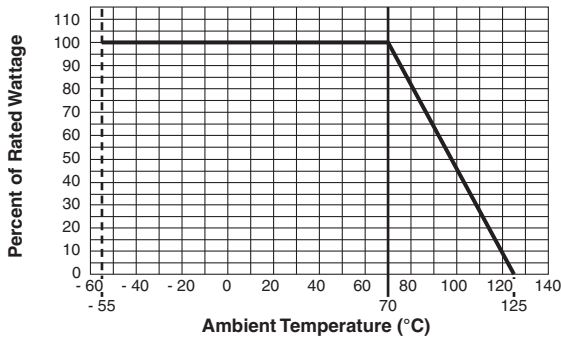

**TABLE 1 - MODEL DSM SPECIFICATIONS**

MODEL	ABSOLUTE TCR ( $-55^\circ\text{C}$ TO $+125^\circ\text{C}$ , $+25^\circ\text{C}$ REF.) TYPICAL + MAX. SPREAD	RESISTANCE RATIO	TCR TRACKING	TOLERANCE	
				ABSOLUTE	MATCH
DSM	$\pm 2 \text{ ppm}/^\circ\text{C} \pm 3 \text{ ppm}/^\circ\text{C}$	$R_1/R_2 = 1$	$1.0 \text{ ppm}/^\circ\text{C}$	$\pm 0.02 \%$	$0.01 \%$
		$1 < R_1/R_2 \leq 10$	$2.0 \text{ ppm}/^\circ\text{C}$	$\pm 0.05 \%$	$0.02 \%$
		$10 < R_1/R_2 \leq 120$	$3.0 \text{ ppm}/^\circ\text{C}$	$\pm 0.1 \%$	$0.05 \%$

\* Pb containing terminations are not RoHS compliant, exemptions may apply

**FIGURE 2 - POWER DERATING CURVE**



**FIGURE 3 - TYPICAL RESISTANCE/TEMPERATURE CURVE**  
(For more details, see table 1)

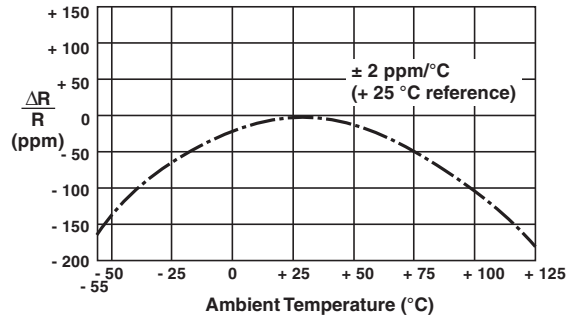

**FIGURE 4 - TRIMMING TO VALUES**  
(Conceptual Illustration)

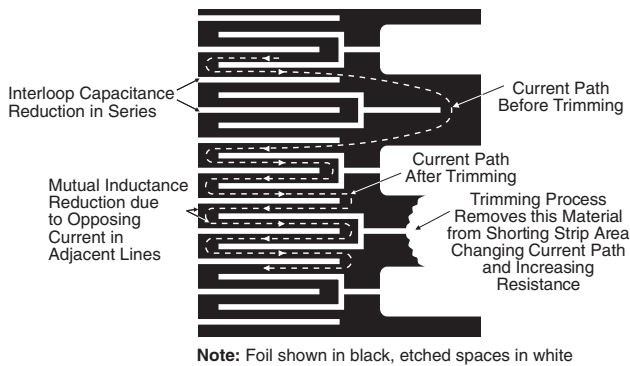

**FIGURE 5 - RECOMMENDED LAND PATTERN**

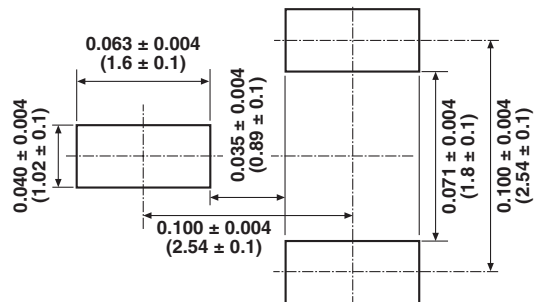

**FIGURE 6 - DIMENSIONS AND IMPRINTING**

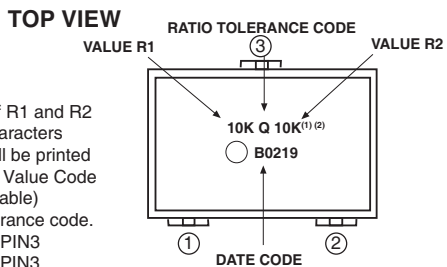
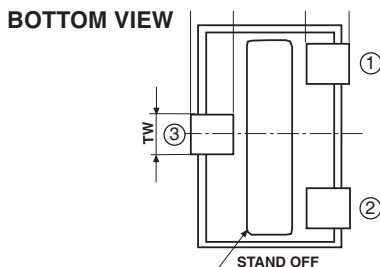
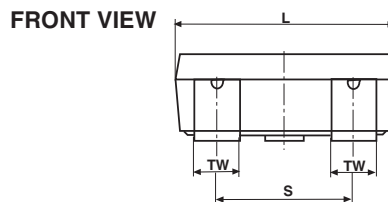
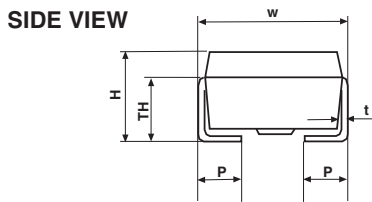

Notes

(1) If the resistance value of R1 and R2 contains more than 6 characters together, the VCODE will be printed instead (see Resistance Value Code List for Popular Ratios Table) followed by the ratio tolerance code.

(2) R1—between PIN1 and PIN3  
R2—between PIN2 and PIN3.

DIMENSIONS	L	W	H	P	TW	TH	S	t
INCHES	0.160 ± 0.008	0.106 ± 0.008	0.063 ± 0.008	0.031 ± 0.005	0.031 ± 0.004	0.043 ± 0.008	0.100 ± 0.008	0.005 ± 0.002
MILLIMETERS	4.06 ± 0.20	2.69 ± 0.20	1.60 ± 0.20	0.79 ± 0.13	0.79 ± 0.10	1.09 ± 0.20	2.54 ± 0.20	0.13 ± 0.05

<b>TABLE 3 - PERFORMANCE SPECIFICATIONS (Test Method Per MIL-PRF-914)</b>	
<b>SPECIFICATIONS</b>	<b>TYPICAL LIMITS</b>
<b>Power Rating</b> at 70 °C	Entire package: 0.1 W Each resistor: 0.05 W
<b>Maximum Working Voltage</b> (each resistor)	25 V
<b>Working Temperature Range</b>	- 65 °C to + 125 °C
<b>Thermal Shock</b> 25 x (- 65 °C to + 125 °C)	$\Delta R = 0.01\%$ (100 ppm) $\Delta \text{Ratio} = 0.005\%$ (50 ppm)
<b>Thermal Shock</b> 5 x (- 65 °C to + 125 °C) and <b>Power Conditioning</b> 1.5 rated power at 25 °C, 100 h	$\Delta R = 0.015\%$ (150 ppm) $\Delta \text{Ratio} = 0.01\%$ (100 ppm)
<b>DWV</b> atmospheric pressure, 200 V (A.C.), 1 min	Successfully passed
<b>Insulation Resistance</b> 100 V (D.C.), 1 min	$> 10^4 \text{ M}\Omega$
<b>Resistance to Soldering Heat</b>	$\Delta R = 0.01\%$ (100 ppm) $\Delta \text{Ratio} = 0.005\%$ (50 ppm)
<b>Moisture Resistance</b> + 65 °C to - 10 °C; 90 % to 98 % RH; 0.1 x rated power, 240 h	$\Delta R = 0.02\%$ (200 ppm) $\Delta \text{Ratio} = 0.005\%$ (50 ppm)
<b>Shock (Specified Pulse)</b> 100 G	$\Delta R = 0.005\%$ (50 ppm) $\Delta \text{Ratio} = 0.0025\%$ (25 ppm)
<b>Vibration, High Frequency</b> (10 Hz to 2000 Hz), 20 G	$\Delta R = 0.01\%$ (100 ppm) $\Delta \text{Ratio} = 0.005\%$ (50 ppm)
<b>High Temperature Exposure</b> 100 h at 125 °C	$\Delta R = 0.01\%$ (100 ppm) $\Delta \text{Ratio} = 0.005\%$ (50 ppm)
<b>Low Temperature Storage</b> 24 h at - 65 °C	$\Delta R = 0.005\%$ (50 ppm) $\Delta \text{Ratio} = 0.005\%$ (50 ppm)
<b>Load Life Stability</b> 2000 h at + 70 °C; rated power	$\Delta R = 0.005\%$ (50 ppm) $\Delta \text{Ratio} = 0.005\%$ (50 ppm)
<b>Short Time Overload</b> 6.25 x rated power; 5 s	$\Delta R = 0.005\%$ (50 ppm) $\Delta \text{Ratio} = 0.0025\%$ (25 ppm)
<b>Low Temperature Operation</b>	$\Delta R = 0.005\%$ (50 ppm) $\Delta \text{Ratio} = 0.0025\%$ (25 ppm)
<b>Weight</b>	0.04 g

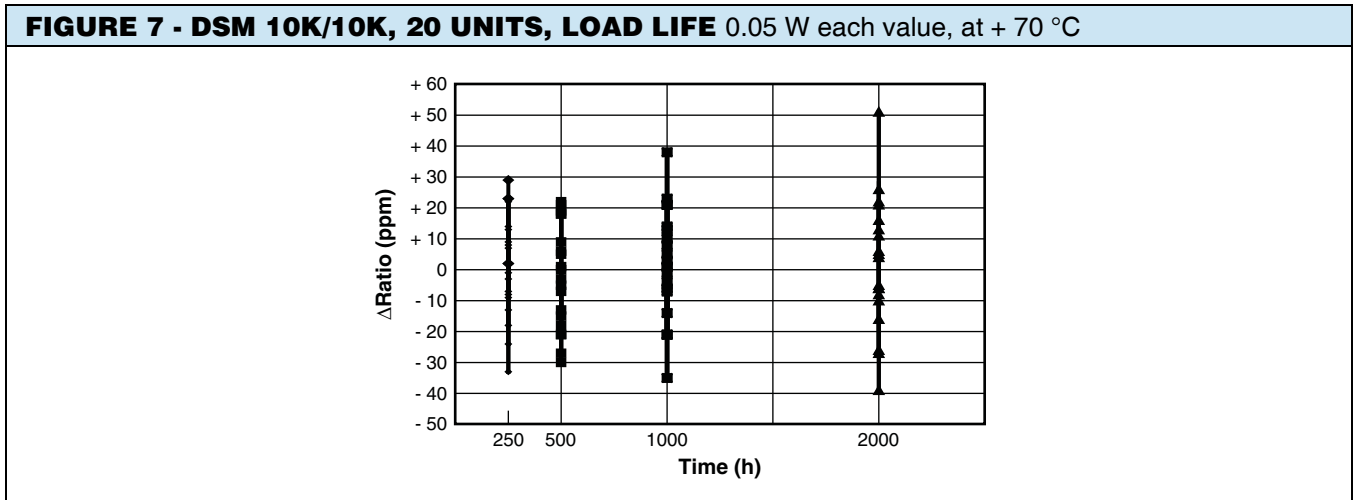

**FIGURE 8 - DSM 10K/10K, 20 UNITS, HIGH TEMPERATURE EXPOSURE,**  
100 h at 125 °C, followed by low temperature storage, 24 h at - 65 °C

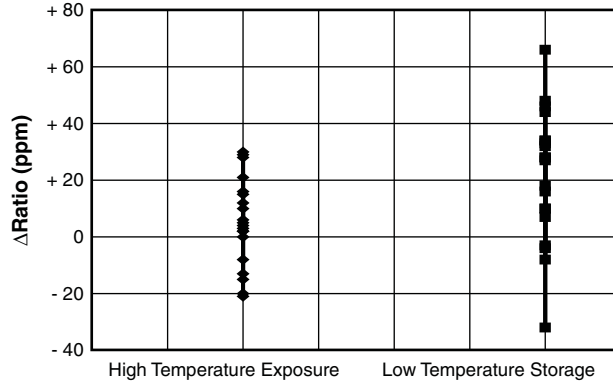
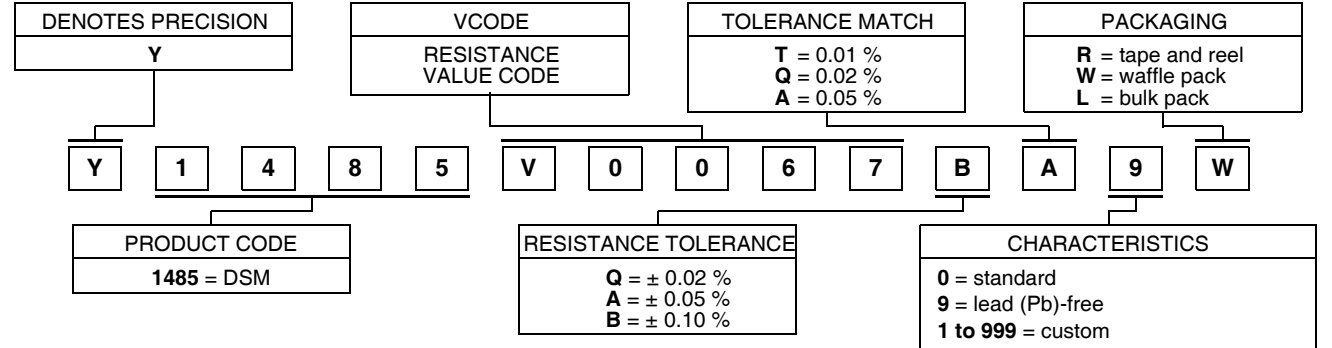

**TABLE 4 - RESISTANCE VALUE CODE LIST FOR POPULAR RATIOS**  
(other values available upon request)

VCODES	R1/R2 RATIO	R1	R2	VCODES	R1/R2 RATIO	R1	R2
V0052	100	10K	100R	V0080	2.5	1K	400R
V0065	50	10K	200R	V0081		500R	200R
V0066		5K	100R	V0082	2	10K	5K
V0067	25	10K	400R	V0083		2K	1K
V0068		5K	200R	V0084		1K	500R
V0069	20	10K	500R	V0085		400R	200R
V0070		2K	100R	V0086	200R	100R	
V0071	10	10K	1K	V0087	1.25	500R	400R
V0072		2K	200R	V0001 V0002 V0059 V0004 V0091 V0090 V0089 V0088	1	10K	10K
V0073		1K	100R			5K	5K
V0074	5	5K	1K			2K	2K
V0075		2K	400R			1K	1K
V0076		1K	200R			500R	500R
V0077		500R	100R			400R	400R
V0246	4	10K	2K5			200R	200R
V0078		2K	500R			100R	100R
V0079		400R	100R				

**TABLE 5 - GLOBAL PART NUMBER INFORMATION (1)**

**NEW GLOBAL PART NUMBER: Y1485V0067BA9W (preferred part number format)**



FOR EXAMPLE: ABOVE GLOBAL ORDER Y1485 V0067 B A 9 W:

TYPE: DSM  
VALUES: 10K/400R  
ABSOLUTE TOLERANCE: ± 0.1 %  
TOLERANCE MATCH: 0.05 %  
TERMINATION: lead (Pb)-free  
PACKAGING: waffle pack

**HISTORICAL PART NUMBER: DSM 10K 400R TCR2 B A S W (will continue to be used)**

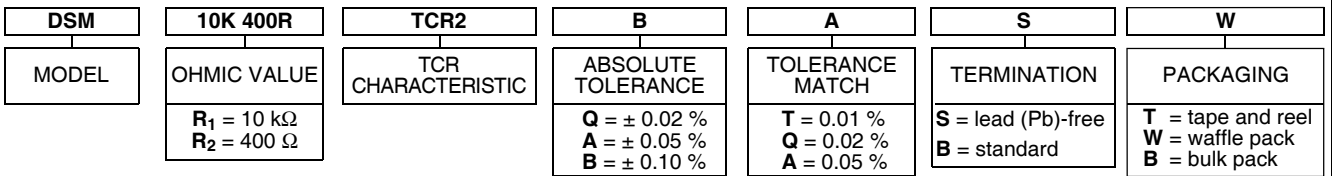

**Note**

(1) For non-standard requests or additional values, please contact application engineering.



## Disclaimer

ALL PRODUCTS, PRODUCT SPECIFICATIONS AND DATA ARE SUBJECT TO CHANGE WITHOUT NOTICE.

Vishay Precision Group, Inc., its affiliates, agents, and employees, and all persons acting on its or their behalf (collectively, "VPG"), disclaim any and all liability for any errors, inaccuracies or incompleteness contained herein or in any other disclosure relating to any product.

The product specifications do not expand or otherwise modify VPG's terms and conditions of purchase, including but not limited to, the warranty expressed therein.

VPG makes no warranty, representation or guarantee other than as set forth in the terms and conditions of purchase. **To the maximum extent permitted by applicable law, VPG disclaims (i) any and all liability arising out of the application or use of any product, (ii) any and all liability, including without limitation special, consequential or incidental damages, and (iii) any and all implied warranties, including warranties of fitness for particular purpose, non-infringement and merchantability.**

Information provided in datasheets and/or specifications may vary from actual results in different applications and performance may vary over time. Statements regarding the suitability of products for certain types of applications are based on VPG's knowledge of typical requirements that are often placed on VPG products. It is the customer's responsibility to validate that a particular product with the properties described in the product specification is suitable for use in a particular application. You should ensure you have the current version of the relevant information by contacting VPG prior to performing installation or use of the product, such as on our website at [vpgsensors.com](http://vpgsensors.com).

No license, express, implied, or otherwise, to any intellectual property rights is granted by this document, or by any conduct of VPG.

The products shown herein are not designed for use in life-saving or life-sustaining applications unless otherwise expressly indicated. Customers using or selling VPG products not expressly indicated for use in such applications do so entirely at their own risk and agree to fully indemnify VPG for any damages arising or resulting from such use or sale. Please contact authorized VPG personnel to obtain written terms and conditions regarding products designed for such applications.

Product names and markings noted herein may be trademarks of their respective owners.

Copyright Vishay Precision Group, Inc., 2014. All rights reserved.

Компания «Океан Электроники» предлагает заключение долгосрочных отношений при поставках импортных электронных компонентов на взаимовыгодных условиях!

Наши преимущества:

- Поставка оригинальных импортных электронных компонентов напрямую с производств Америки, Европы и Азии, а так же с крупнейших складов мира;
- Широкая линейка поставок активных и пассивных импортных электронных компонентов (более 30 млн. наименований);
- Поставка сложных, дефицитных, либо снятых с производства позиций;
- Оперативные сроки поставки под заказ (от 5 рабочих дней);
- Экспресс доставка в любую точку России;
- Помощь Конструкторского Отдела и консультации квалифицированных инженеров;
- Техническая поддержка проекта, помощь в подборе аналогов, поставка прототипов;
- Поставка электронных компонентов под контролем ВП;
- Система менеджмента качества сертифицирована по Международному стандарту ISO 9001;
- При необходимости вся продукция военного и аэрокосмического назначения проходит испытания и сертификацию в лаборатории (по согласованию с заказчиком);
- Поставка специализированных компонентов военного и аэрокосмического уровня качества (Xilinx, Altera, Analog Devices, Intersil, Interpoint, Microsemi, Actel, Aeroflex, Peregrine, VPT, Syfer, Eurofarad, Texas Instruments, MS Kennedy, Miteq, Cobham, E2V, MA-COM, Hittite, Mini-Circuits, General Dynamics и др.);

Компания «Океан Электроники» является официальным дистрибьютором и эксклюзивным представителем в России одного из крупнейших производителей разъемов военного и аэрокосмического назначения «JONHON», а так же официальным дистрибьютором и эксклюзивным представителем в России производителя высокотехнологичных и надежных решений для передачи СВЧ сигналов «FORSTAR».



## JONHON

«JONHON» (основан в 1970 г.)

Разъемы специального, военного и аэрокосмического назначения:

(Применяются в военной, авиационной, аэрокосмической, морской, железнодорожной, горно- и нефтедобывающей отраслях промышленности)

«FORSTAR» (основан в 1998 г.)

ВЧ соединители, коаксиальные кабели,  
кабельные сборки и микроволновые компоненты:

(Применяются в телекоммуникациях гражданского и специального назначения, в средствах связи, РЛС, а так же военной, авиационной и аэрокосмической отраслях промышленности).



Телефон: 8 (812) 309-75-97 (многоканальный)

Факс: 8 (812) 320-03-32

Электронная почта: [ocean@oceanchips.ru](mailto:ocean@oceanchips.ru)

Web: <http://oceanchips.ru/>

Адрес: 198099, г. Санкт-Петербург, ул. Калинина, д. 2, корп. 4, лит. А