

DATA SHEET

SKY12239-11: High IIP3 10 MHz to 1.5 GHz Voltage-Controlled Variable Attenuator

Applications

- Automatic power leveling/gain control circuits in cellular base stations and point-to-point radio IF chains
- General wireless systems including WiMAX, LTE, WCDMA, VSAT, and military communications

Features

- 10 MHz to 1.5 GHz broadband operating range
- Low insertion loss: 2.5 dB @ 700 MHz
- Maximum attenuation level: 40 dB @ 700 MHz
- Control voltage range: 1 to 5 V
- High IIP3: +50 dBm
- Low current consumption: < 2 mA @ maximum attenuation
- Small MCM (8-pin, 3.8 x 3.8 x 1 mm) package (MSL3, 260 °C per JEDEC J-STD-020)

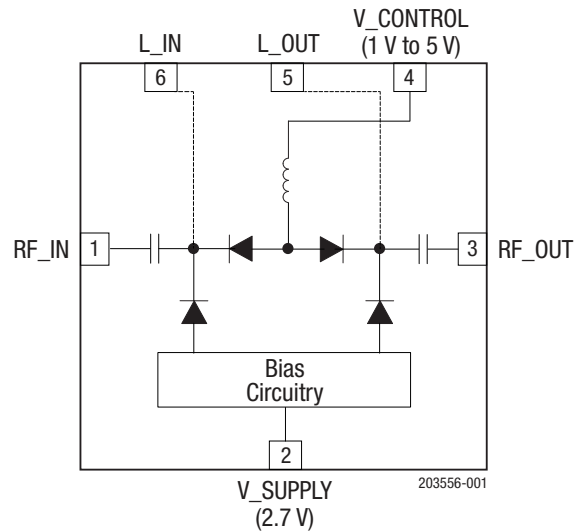

Figure 1. SKY12239-11 Block Diagram



Skyworks Green™ products are compliant with all applicable legislation and are halogen-free. For additional information, refer to *Skyworks Definition of Green™*, document number SQ04-0074.

Description

The SKY12239-11 is a voltage-controlled variable attenuator from Skyworks series of broadband, flat attenuation, high third order input intercept point (IIP3) components. The device has been designed to operate over the 10 MHz to 1.5 GHz frequency band, and is specifically optimized for use as a wide dynamic range, low distortion attenuator.

The SKY12239-11 provides monotonic attenuation performance over its entire control voltage range. This attenuator is comprised of four matched PIN diodes that are biased using an external control voltage signal. The attenuator requires no external components. It operates with a control voltage range of 1 to 5 V and a 2 mA typical control current at maximum attenuation.

A functional block diagram is shown in Figure 1. The pin configuration and package are shown in Figure 2. Signal pin assignments and functional pin descriptions are provided in Table 1.

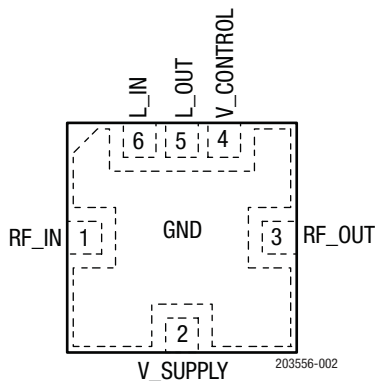

Figure 2. SKY12239-11 Pinout (Top View)

Table 1. SKY12239-11 Signal Descriptions

Pin	Name	Description	Pin	Name	Description
1	RF_IN	RF input, AC coupled. No external components required.	5	L_OUT	Phase compensation inductor output
2	V_SUPPLY	Fixed reference supply, 2.7 Vdc.	6	L_IN	Phase compensation inductor input
3	RF_OUT	RF output, AC coupled. No external components required.	7	GND	Paddle of the device. Ground to the Applications Board. Provides thermal contact and RF ground.
4	V_CONTROL	Variable reference supply, 1.0 V to 5.0 Vdc.			

Technical Description

The SKY12239-11 is a 50 Ω matched voltage controlled variable attenuator with monotonic attenuation performance from 10 MHz to 1.5 GHz over its entire control voltage range. This attenuator requires no external biasing or RF matching components.

Monotonic performance means the attenuation increases or decreases as the applied DC voltage increases or decreases. This attenuator is comprised of four matched PIN diodes that terminate two ports of an internal matching network.

The diodes are biased using an external control voltage signal that sets the bias current through a resistive network. The attenuator operates with a control voltage range of 1 to 5 V and a 2 mA typical control current at maximum attenuation. As the control voltage increases, the bias current through each of the PIN diodes also increases.

This increased bias current lowers the resistance of the PIN diodes. Maximum attenuation occurs when the resistance of the PIN diodes is at maximum (control voltage of approximately 1 VDC).

Electrical and Mechanical Specifications

The absolute maximum ratings of the SKY12239-11 are provided in Table 2. Electrical specifications are provided in Table 3.

Performance characteristics for the SKY12239-11 are illustrated in Figures 3 through 8.

Table 2. SKY12239-11 Absolute Maximum Ratings¹

Parameter	Symbol	Minimum	Maximum	Units
Control voltage	VCTRL	0	5.5	V
Reference voltage	VSUPPLY		5.5	V
RF input power (CW)	PIN		1	W
Control current	ICC		50	mA
Thermal impedance (VCTRL = 5 V, VSUPPLY = 2.7 V, PIN = +21 dBm)	θJC		+94	°C/W
Storage temperature	TSTG	-55	+125	°C
Operating temperature	TOP	-40	+105	°C
Electrostatic discharge:	ESD			
Charged Device Model (CDM), Class C3			1000	V
Human Body Model (HBM), Class 2			3000	V

¹ Exposure to maximum rating conditions for extended periods may reduce device reliability. There is no damage to device with only one parameter set at the limit and all other parameters set at or below their nominal value. Exceeding any of the limits listed here may result in permanent damage to the device.

ESD HANDLING: *Although this device is designed to be as robust as possible, electrostatic discharge (ESD) can damage this device. This device must be protected at all times from ESD when handling or transporting. Static charges may easily produce potentials of several kilovolts on the human body or equipment, which can discharge without detection. Industry-standard ESD handling precautions should be used at all times.*

Table 3. SKY12239-11 Electrical Specifications¹

(TOP = +25 °C, VCTRL = 1 to 5 V, VSUPPLY = 2.7 V, PIN = 0 dBm, Characteristic Impedance [Zo] = 50 Ω, Unless Otherwise Noted)

Parameter	Symbol	Test Condition	Min ²	Typ	Max	Units
RF Specifications						
Insertion loss (VCTRL = 5 V)	IS21I	100 MHz		2		dB
		700 MHz		2.5	3.5	dB
		1500 MHz		3		dB
Maximum attenuation (VCTRL = 1 V)	IS21I	100 MHz		51		dB
		700 MHz	35	40		dB
		1500 MHz		33		dB
IRL maximum attenuation (VCTRL = 1 V)	IS11I	100 MHz		29		dB
		700 MHz		28		dB
		1500 MHz		22		dB
ORL maximum attenuation (VCTRL = 1 V)	IS22I	100 MHz		29		dB
		700 MHz		27		dB
		1500 MHz		21		dB
IRL minimum attenuation (VCTRL = 5 V)	IS11I	100 MHz		37		dB
		700 MHz		19		dB
		1500 MHz		13		dB
ORL minimum attenuation (VCTRL = 5 V)	IS22I	100 MHz		37		dB
		700 MHz		19		dB
		1500 MHz		13		dB
Third order input intercept point (VCTRL = 5 V)	IIP3	100 MHz, 1 MHz tone spacing, +22 dBm/tone		50		dBm
		700 MHz, 1 MHz tone spacing, +22 dBm/tone		50		dBm
		1500MHz, 1 MHz tone spacing, +22 dBm/tone		50		dBm
1 dB input compression point (VCTRL = 5 V)	IP1dB	12.5% duty cycle		34		dBm
				40		dBm
				40		dBm
Phase shift @ 150 nH ³	φ	700 MHz		15		degree
DC Specifications						
Control voltage (VCTRL)	VCTRL	1.0 to 5.0 V nominal	1	5	5.5	V
Control current (ICTL)	ICTL	5.0 V, VCTRL; 2.7 V, VSUPPLY		20		mA
Supply voltage (VSUPPLY)	VSUPPLY	Fixed supply		2.7		V
Supply current (ISUPPLY)	ISUPPLY			2		mA
Settling time @ 700 MHz	tSETTLE	VSUPPLY = 2.7 V, VCTRL change from 5 V to 1 V, settled within 0.2 dB of respective state, 10 KHz repetitive rate, 50% duty cycle		8		μs

¹ Performance is guaranteed only under the conditions listed in this table.

² Minimum specification is guaranteed by design and is not 100% production tested.

³ L1 is 0201 size, 150 nH inductor from TDK. Part number is MLG0603SR15J.

Typical Performance Characteristics

(TOP = +25 °C, VCTRL = 0 to 5 V, PIN = 0 dBm, Characteristic Impedance [Z0] = 50 Ω, J1 = Input Port, J2 = Output Port, Unless Otherwise Noted)

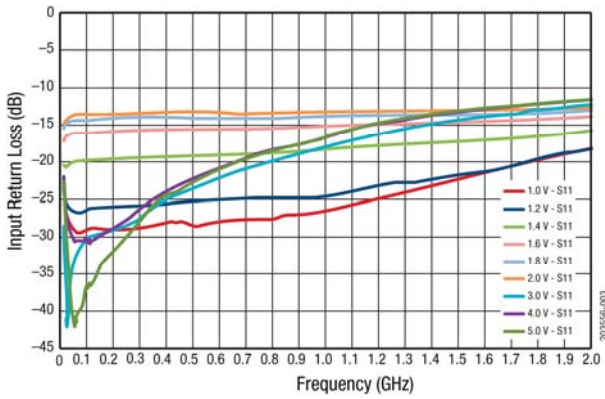

Figure 3. Attenuation vs Frequency over Control Voltage

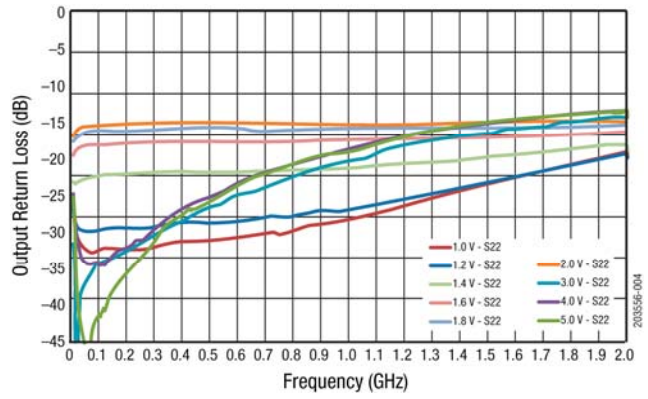

Figure 4. Input Return Loss vs Frequency over Control Voltage

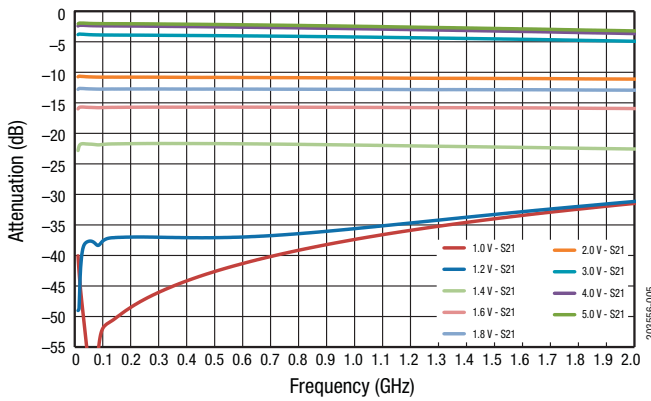
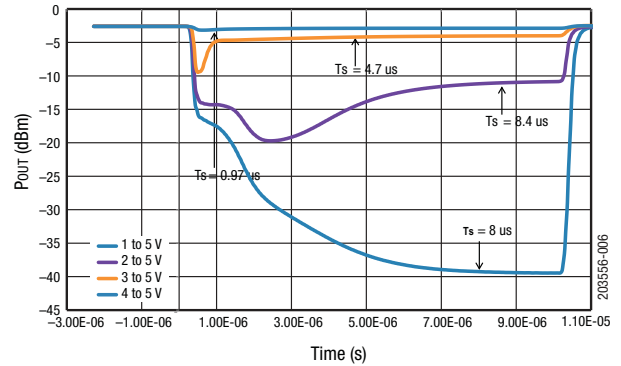

Figure 5. Output Return Loss vs Frequency over Control Voltage



Note: Settling Time -0.2 dB from final settled value.

Figure 6. Settling Time -Falling Edge (f = 700 MHz, Rep Rate = 50 kHz, Duty Cycle = 50%, 25 °C)

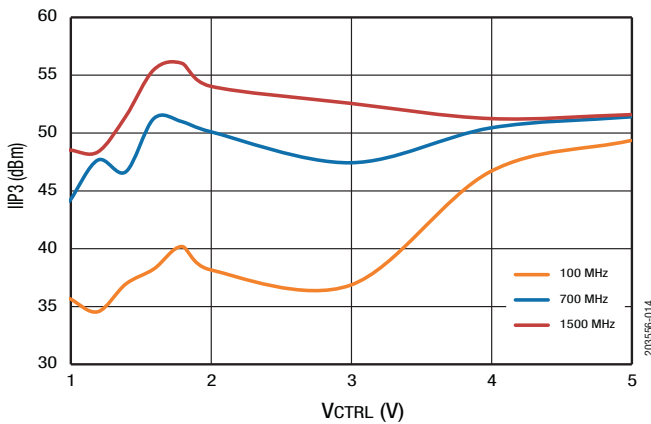

Figure 7. IIP3 vs VCTRL over Frequency (1 MHz tone spacing, +22 dBm/tone)

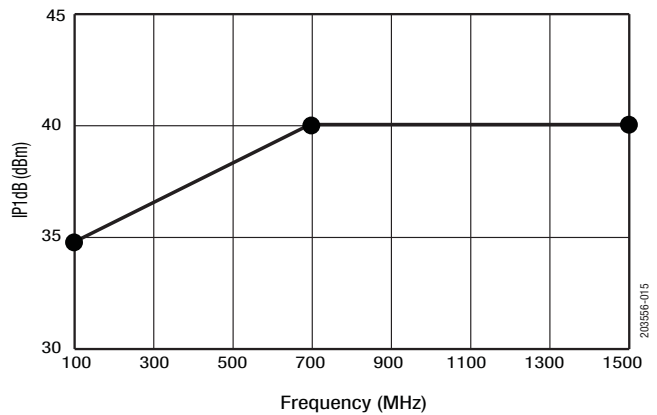

Figure 8. IP1dB vs Frequency

Evaluation Board Description

The SKY12239-11 Evaluation Board is used to test the performance of the SKY12239-11 variable attenuator. A schematic of the Evaluation Board is shown in Figure 9. Table 4 lists the Bill of Materials. An assembly drawing for the Evaluation Board is shown in Figure 10. The Evaluation Board layer detail is shown in Figure 11.

The attenuation level of the SKY12239-11 is controlled by applying 1 to 5 V to the V_CONTROL pins.

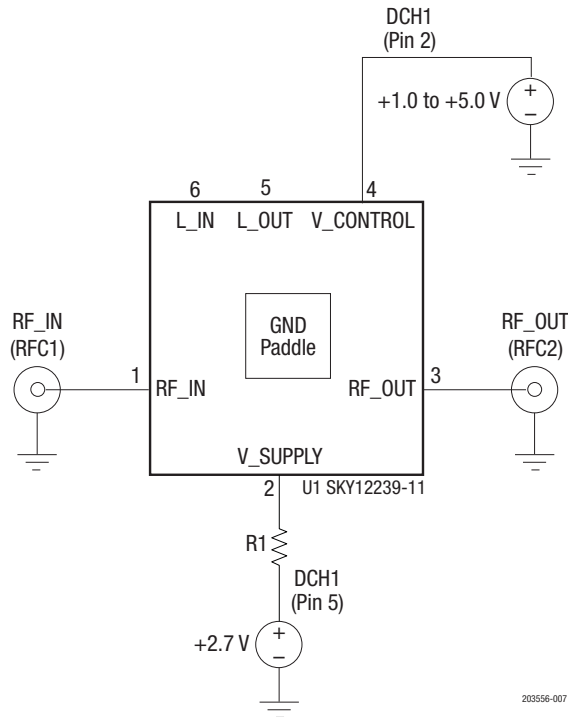

Figure 9. SKY12239-11 Evaluation Board Schematic

Table 4. SKY12239-11 Evaluation Board Bill of Materials (BOM)

Component	Description	Value	Size
R1	Resistor	0 Ω	0402
L1	Inductor	DNI	0402

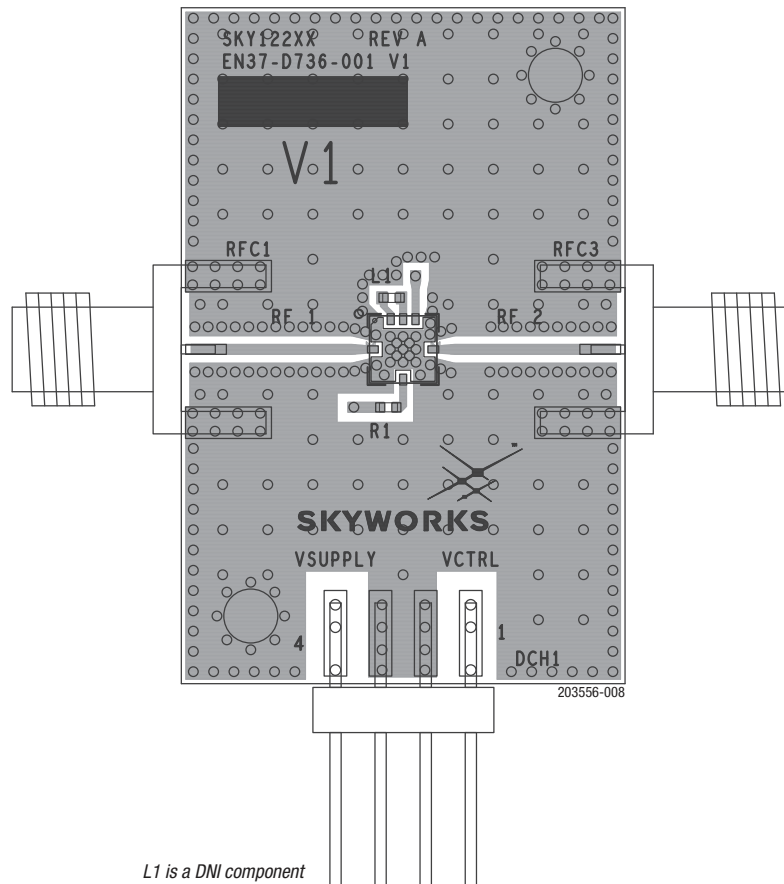

Figure 10. SKY12239-11 Evaluation Board Assembly Diagram

Cross Section	Name	Thickness (in)	Material
	Top Solder Mask		
	L1	(0.0007)	Finished Copper Thickness
	Dielectric	0.010	Rogers R04350 Core
	L2	(0.0007)	Finished Copper Thickness
	Dielectric	(Note 1)	FR4 Prepreg
	L3	(0.0007)	Finished Copper Thickness
	Bottom Solder Mask		

Note 1: Adjust this thickness to meet total thickness goal of 0.062 ± 0.005 inch.

203556-009

Figure 11. Layer Detail Physical Characteristics

Package Dimensions

The PCB layout footprint for the SKY12239-11 is shown in Figure 12. Typical part markings are shown in Figure 13. Package dimensions are shown in Figure 14, and tape and reel dimensions are provided in Figure 15.

Package and Handling Information

Since the device package is sensitive to moisture absorption, it is baked and vacuum packed before shipping. Instructions on the shipping container label regarding exposure to moisture after the container seal is broken must be followed. Otherwise, problems related to moisture absorption may occur when the part is subjected to high temperature during solder assembly.

The SKY12239-11 is rated to Moisture Sensitivity Level 3 (MSL3) at 260 °C. It can be used for lead or lead-free soldering. For additional information, refer to the Skyworks Application Note, *PCB Design & SMT Assembly/Rework Guidelines for MCM-L Packages*, document number 101752.

Care must be taken when attaching this product, whether it is done manually or in a production solder reflow environment. Production quantities of this product are shipped in a standard tape and reel format.

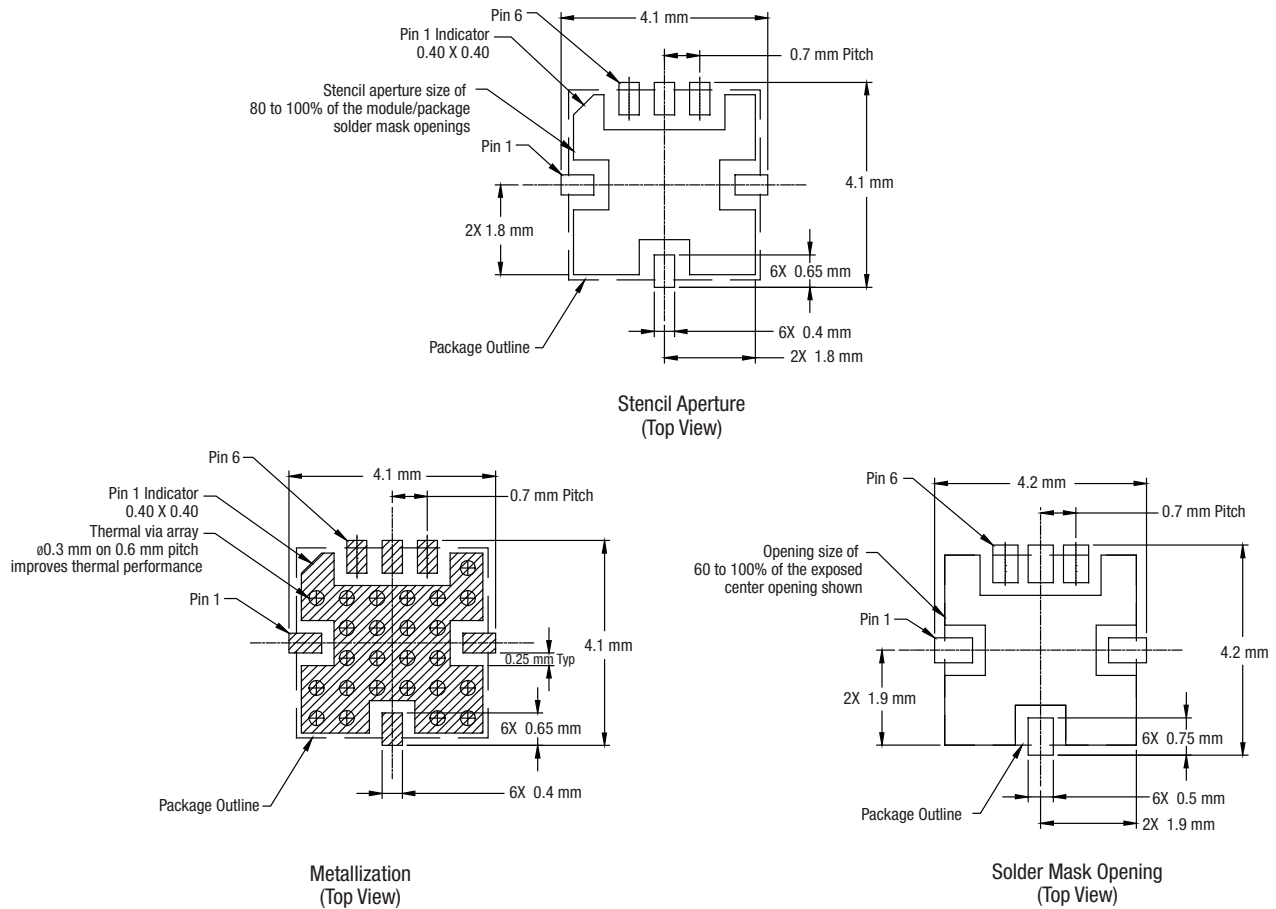

- Notes:
1. Thermal vias should be resin filled and capped in accordance with IPC-4761 type VII vias.
 2. Recommended Cu thickness is 30 to 35 μm.

203556-010

Figure 12. SKY12239-11 PCB Layout Footprint

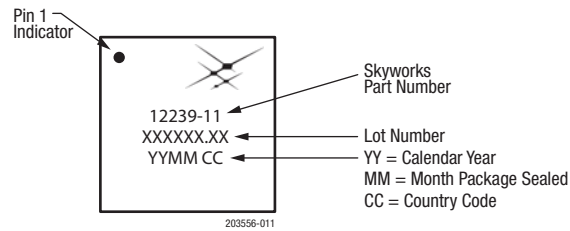
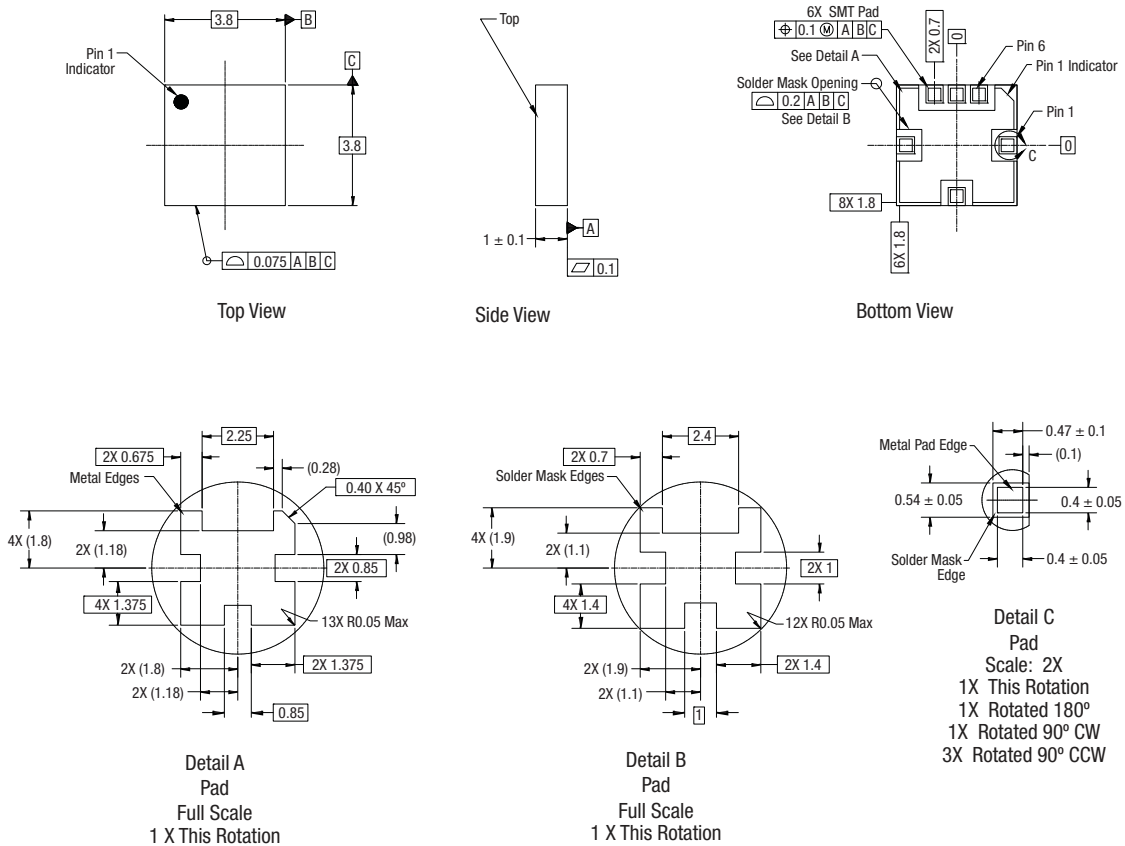

Figure 13. Typical Part Markings (Top View)



Notes:
 1. Dimensions and tolerances in accordance with ASME Y14.5M-1994.
 2. All measurements are in millimeters.

203556-012

Figure 14. SKY12239-11 Package Dimensions

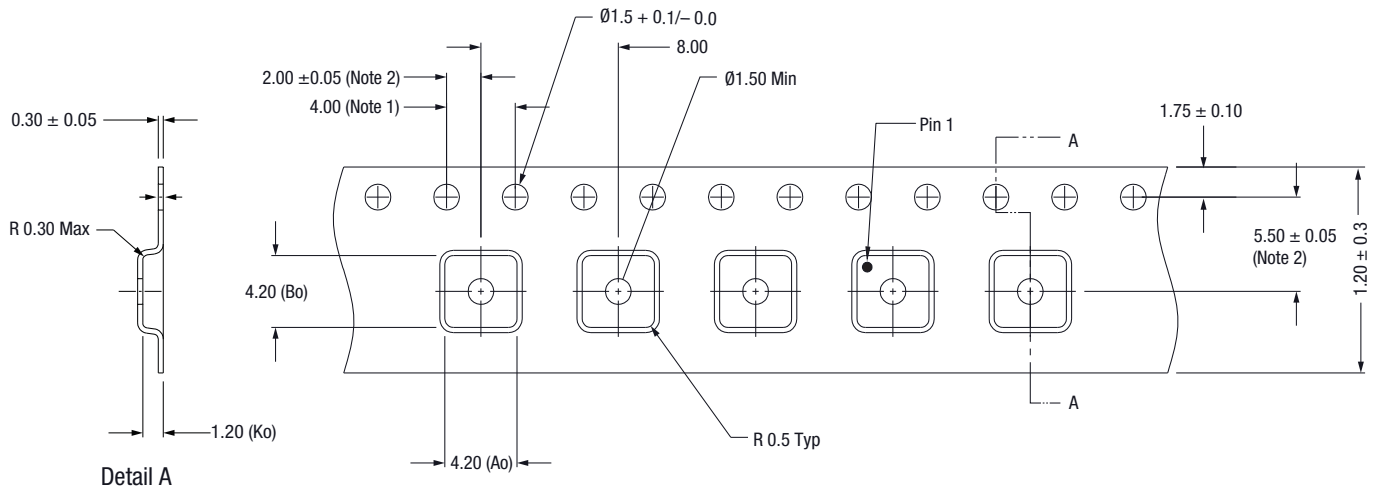

Notes:

1. 10-sprocket hole pitch cumulative tolerance: ± 0.2 mm.
2. Pocket position relative to sprocket hole measured as true position of pocket, not pocket hole.
3. Ao and Bo are calculated on a plane at a distance "R" above the bottom of the pocket.
4. All dimensions are in millimeters.

203556-013

Figure 15. SKY12239-11 Tape and Reel Dimensions

Ordering Information

Part Number	Product Description	Evaluation Board Part Number
SKY12239-11	High IIP3 10 MHz to 1.5 GHz Voltage-Controlled Variable Attenuator	SKY12239-11-EVB

Copyright © 2016-2018 Skyworks Solutions, Inc. All Rights Reserved.

Information in this document is provided in connection with Skyworks Solutions, Inc. (“Skyworks”) products or services. These materials, including the information contained herein, are provided by Skyworks as a service to its customers and may be used for informational purposes only by the customer. Skyworks assumes no responsibility for errors or omissions in these materials or the information contained herein. Skyworks may change its documentation, products, services, specifications or product descriptions at any time, without notice. Skyworks makes no commitment to update the materials or information and shall have no responsibility whatsoever for conflicts, incompatibilities, or other difficulties arising from any future changes.

No license, whether express, implied, by estoppel or otherwise, is granted to any intellectual property rights by this document. Skyworks assumes no liability for any materials, products or information provided hereunder, including the sale, distribution, reproduction or use of Skyworks products, information or materials, except as may be provided in Skyworks Terms and Conditions of Sale.

THE MATERIALS, PRODUCTS AND INFORMATION ARE PROVIDED “AS IS” WITHOUT WARRANTY OF ANY KIND, WHETHER EXPRESS, IMPLIED, STATUTORY, OR OTHERWISE, INCLUDING FITNESS FOR A PARTICULAR PURPOSE OR USE, MERCHANTABILITY, PERFORMANCE, QUALITY OR NON-INFRINGEMENT OF ANY INTELLECTUAL PROPERTY RIGHT; ALL SUCH WARRANTIES ARE HEREBY EXPRESSLY DISCLAIMED. SKYWORKS DOES NOT WARRANT THE ACCURACY OR COMPLETENESS OF THE INFORMATION, TEXT, GRAPHICS OR OTHER ITEMS CONTAINED WITHIN THESE MATERIALS. SKYWORKS SHALL NOT BE LIABLE FOR ANY DAMAGES, INCLUDING BUT NOT LIMITED TO ANY SPECIAL, INDIRECT, INCIDENTAL, STATUTORY, OR CONSEQUENTIAL DAMAGES, INCLUDING WITHOUT LIMITATION, LOST REVENUES OR LOST PROFITS THAT MAY RESULT FROM THE USE OF THE MATERIALS OR INFORMATION, WHETHER OR NOT THE RECIPIENT OF MATERIALS HAS BEEN ADVISED OF THE POSSIBILITY OF SUCH DAMAGE.

Skyworks products are not intended for use in medical, lifesaving or life-sustaining applications, or other equipment in which the failure of the Skyworks products could lead to personal injury, death, physical or environmental damage. Skyworks customers using or selling Skyworks products for use in such applications do so at their own risk and agree to fully indemnify Skyworks for any damages resulting from such improper use or sale.

Customers are responsible for their products and applications using Skyworks products, which may deviate from published specifications as a result of design defects, errors, or operation of products outside of published parameters or design specifications. Customers should include design and operating safeguards to minimize these and other risks. Skyworks assumes no liability for applications assistance, customer product design, or damage to any equipment resulting from the use of Skyworks products outside of stated published specifications or parameters.

Skyworks and the Skyworks symbol are trademarks or registered trademarks of Skyworks Solutions, Inc. or its subsidiaries in the United States and other countries. Third-party brands and names are for identification purposes only, and are the property of their respective owners. Additional information, including relevant terms and conditions, posted at www.skyworksinc.com, are incorporated by reference.

Компания «Океан Электроники» предлагает заключение долгосрочных отношений при поставках импортных электронных компонентов на взаимовыгодных условиях!

Наши преимущества:

- Поставка оригинальных импортных электронных компонентов напрямую с производств Америки, Европы и Азии, а так же с крупнейших складов мира;
- Широкая линейка поставок активных и пассивных импортных электронных компонентов (более 30 млн. наименований);
- Поставка сложных, дефицитных, либо снятых с производства позиций;
- Оперативные сроки поставки под заказ (от 5 рабочих дней);
- Экспресс доставка в любую точку России;
- Помощь Конструкторского Отдела и консультации квалифицированных инженеров;
- Техническая поддержка проекта, помощь в подборе аналогов, поставка прототипов;
- Поставка электронных компонентов под контролем ВП;
- Система менеджмента качества сертифицирована по Международному стандарту ISO 9001;
- При необходимости вся продукция военного и аэрокосмического назначения проходит испытания и сертификацию в лаборатории (по согласованию с заказчиком);
- Поставка специализированных компонентов военного и аэрокосмического уровня качества (Xilinx, Altera, Analog Devices, Intersil, Interpoint, Microsemi, Actel, Aeroflex, Peregrine, VPT, Syfer, Eurofarad, Texas Instruments, MS Kennedy, Miteq, Cobham, E2V, MA-COM, Hittite, Mini-Circuits, General Dynamics и др.);

Компания «Океан Электроники» является официальным дистрибьютором и эксклюзивным представителем в России одного из крупнейших производителей разъемов военного и аэрокосмического назначения «JONHON», а так же официальным дистрибьютором и эксклюзивным представителем в России производителя высокотехнологичных и надежных решений для передачи СВЧ сигналов «FORSTAR».



JONHON

«JONHON» (основан в 1970 г.)

Разъемы специального, военного и аэрокосмического назначения:

(Применяются в военной, авиационной, аэрокосмической, морской, железнодорожной, горно- и нефтедобывающей отраслях промышленности)

«FORSTAR» (основан в 1998 г.)

ВЧ соединители, коаксиальные кабели, кабельные сборки и микроволновые компоненты:

(Применяются в телекоммуникациях гражданского и специального назначения, в средствах связи, РЛС, а так же военной, авиационной и аэрокосмической отраслях промышленности).



Телефон: 8 (812) 309-75-97 (многоканальный)

Факс: 8 (812) 320-03-32

Электронная почта: ocean@oceanchips.ru

Web: <http://oceanchips.ru/>

Адрес: 198099, г. Санкт-Петербург, ул. Калинина, д. 2, корп. 4, лит. А