

## 1 to 3 Cells Li-Ion Battery Protection IC for Secondary Protection

No. EA-416-180612

### OUTLINE

The R5437L is an overcharge protection IC for 1 to 3 serial cells Li-ion / Li-polymer rechargeable battery. This device provides the high-accuracy voltage detection function and the shutdown function can reduce the supply current to the minimum when all cell's voltage becomes less than the shutdown detection voltage.

### FEATURES

- High Voltage Tolerant Process  
Absolute Maximum Ratings ..... 26 V
- Low Supply Current  
During Operation, Cell-voltage: 3.9 V, 3-Cells ..... Typ. 0.85  $\mu$ A
- High-accuracy Voltage Detection  
Overcharge Detector Threshold ( $V_{DET1n}^{(1)}$ ) ..... 4.10 V to 4.60 V, in 5 mV step  
Overcharge Detector Threshold Accuracy .....  $\pm 0.02$  V ( $T_a = 25^\circ\text{C}$ )  
 $\pm 0.025$  V ( $0^\circ\text{C} \leq T_a \leq 60^\circ\text{C}$ )  
  
Overcharge Release Voltage ( $V_{REL1n}^{(1)}$ ) .....  $V_{DET1n} - 0\text{V}$  to  $V_{DET1n} - 0.5\text{V}$ , in 50 mV step  
  
Overcharge Detection Delay Time ..... 2-, 4-, or 6-sec with Delay Time Shortening Function<sup>(2)</sup>  
Overcharge Release Voltage Condition ..... Voltage Release Type
- COUT Output (CMOS Output, Active-high) ..... Typ. 4.7 V
- Shutdown Functions  
Shutdown Detector Threshold ..... Typ. 3.5 V  $\pm 0.3$  V  
Shutdown Current ..... Max. 0.1  $\mu$ A
- 1 to 3 Cells Selectable Battery Protection
- Compact Package  
DFN1814-6C ..... 1.4mm x 1.8mm

### APPLICATIONS

- Li-Ion or Li-Polymer Battery Protection

<sup>(1)</sup>  $V_{DET1n}, V_{REL1n}$ : n = 1, 2, 3

<sup>(2)</sup> The delay time can be reduced down to approx. 1/90 by applying a 4 V  $\pm 0.2$  V to the VDD – VC1 pins.

---

## R5437L

---

No. EA-416-180612

### SELECTION GUIDE

The overcharge and the delay time are user-selectable options.

#### Selection Guide

Product Name	Package	Quantity per Reel	Pb Free	Halogen Free
R5437Lxxx\$*-TR	DFN1814-6C	5,000 pcs	Yes	Yes

xxx: Specify the combination of the overcharge detector threshold ( $V_{DET1n}$ ) and the overcharge release voltage ( $V_{REL1n}$ )<sup>(1)</sup>.

$V_{DET1n}$ <sup>(2)</sup>: 4.1 V to 4.6 V in 5 mV step

$V_{REL1n}$ <sup>(2)</sup>:  $V_{DET1n} - 0$  V to  $V_{DET1n} - 0.5$  V in 50 mV step

\$: Specify the combination of the overcharge detection delay time ( $t_{VDET1}$ ) and the overcharge release delay time ( $t_{VREL1}$ ). Refer to *Delay Time Code Table* for details.

#### Delay Time Code Table

Code	$t_{VDET1}$ (s)	$t_{VREL1}$ (ms)
A	2	16
B	4	16
C	6	16

\*: Specify the function code.

#### Function Code Table

Code	Overcharge Released Condition	COUT Output	
A	Voltage Release	CMOS	"H" Active

---

<sup>(1)</sup> Refer to *Product Code Table* for details.

<sup>(2)</sup>  $V_{DET1n}, V_{REL1n}$ :  $n = 1, 2, 3$

**Product Code List**

The product code is determined by the combination of the settable voltage (overcharge detector threshold:  $V_{DET1n}$  and overcharge release voltage:  $V_{REL1n}$ ) and the delay time (overcharge detection delay time:  $t_{VDET1}$  and overcharge release delay time:  $t_{VREL1}$ ) and the function code.

**Product Code Table**

Product Name	Settable Voltage (V)		Delay Time	
	$V_{DET1n}$	$V_{REL1n}$	$t_{VDET1}(s)$	$t_{VREL1}(ms)$
R5437L301AA	4.450	4.150	2	16
R5437L301BA	4.450	4.150	4	16
R5437L303AA	4.350	4.050	2	16
R5437L303BA	4.350	4.050	4	16
R5437L303CA	4.350	4.050	6	16
R5437L304AA	4.400	4.100	2	16
R5437L304BA	4.400	4.100	4	16
R5437L305AA	4.300	4.000	2	16
R5437L305BA	4.300	4.000	4	16
R5437L306CA	4.450	3.950	6	16
R5437L307CA	4.500	4.100	6	16
R5437L312AA	4.550	4.150	2	16
R5437L312BA	4.550	4.150	4	16
R5437L317BA	4.500	4.200	4	16
R5437L322BA	4.600	4.150	4	16

**BLOCK DIAGRAM**

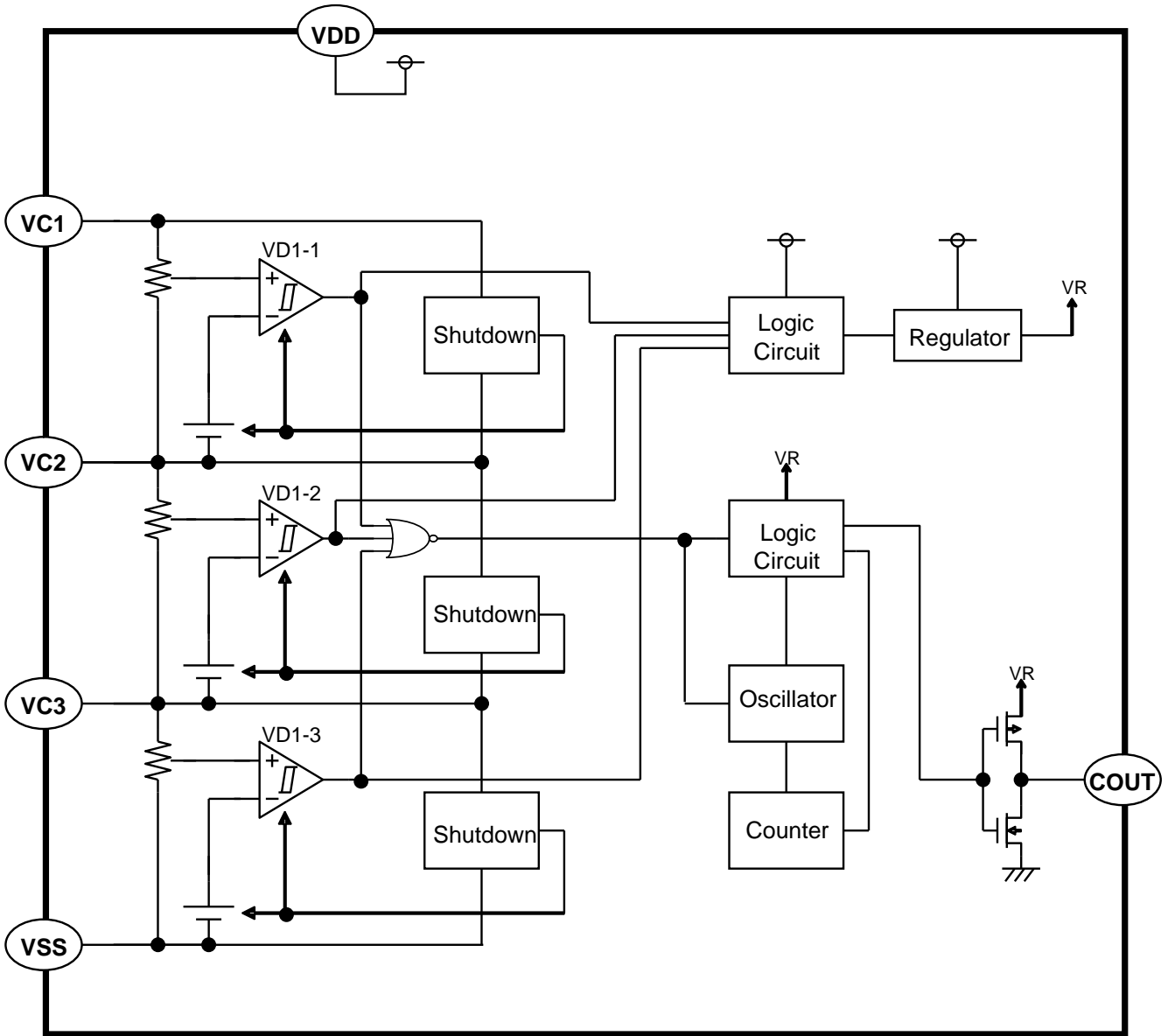

R5437L Block Diagram

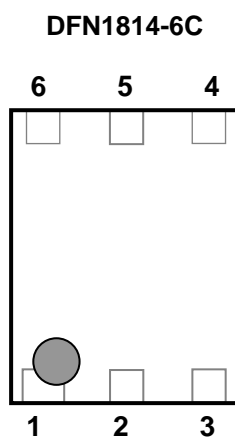
**PIN DESCRIPTIONS****DFN1814-6C Pin Assignment**

Pin No.	Symbol	Description
1	VC1	CELL1 Plus Pin
2	VC2	CELL2 Plus Pin
3	VSS	IC Ground Pin
4	VC3	CELL3 Plus Pin
5	VDD	Power Supply Pin
6	COUT	Overcharge Detection Output Pin

---

**R5437L**

---

No. EA-416-180612

**ABSOLUTE MAXIMUM RATINGS****Absolute Maximum Ratings**(Ta = 25°C, V<sub>SS</sub> = 0 V)

Symbol	Item	Rating	Unit
V <sub>DD</sub>	Power Supply Voltage	V <sub>C1</sub> -0.3 to V <sub>C1</sub> +6.5	V
		V <sub>C1</sub> -0.3 to 26	V
V <sub>C1</sub>	CELL1 Plus Pin Input Voltage	V <sub>C2</sub> -0.3 to V <sub>C2</sub> +6.5	V
V <sub>C2</sub>	CELL2 Plus Pin Input Voltage	V <sub>C3</sub> -0.3 to V <sub>C3</sub> +6.5	V
V <sub>C3</sub>	CELL3 Plus Pin Input Voltage	-0.3 to 6.5	V
V <sub>COU</sub> T	COU T Pin Output Voltage	-0.3 to V <sub>OH1</sub> +0.3	V
P <sub>D</sub>	Power Dissipation (Standard Land Pattern)	150	mW
T <sub>j</sub>	Junction Temperature Range	-40 to 125	°C
T <sub>stg</sub>	Storage Temperature Range	-55 to 125	°C

**ABSOLUTE MAXIMUM RATINGS**

Electronic and mechanical stress momentarily exceeded absolute maximum ratings may cause the permanent damages and may degrade the life time and safety for both device and system using the device in the field. The functional operation at or over these absolute maximum ratings is not assured.

**RECOMMENDED OPERATING CONDITION**

Symbol	Item	Rating	Unit
V <sub>DD</sub>	Operating Input Voltage	1.5 to 20 /	V
		V <sub>C1</sub> +5 V	
T <sub>a</sub>	Operating Temperature Range	-40 to 85	°C

**RECOMMENDED OPERATING CONDITIONS**

All of electronic equipment should be designed that the mounted semiconductor devices operate within the recommended operating conditions. The semiconductor devices cannot operate normally over the recommended operating conditions, even if when they are used over such conditions by momentary electronic noise or surge. And the semiconductor devices may receive serious damage when they continue to operate over the recommended operating conditions.

## ELECTRICAL CHARACTERISTICS

$V_{CELLn} = CELLn$  (Ex.  $V_{CELL1}$  is a voltage difference between VC1 and VC2)

$n = 1, 2, 3$ , unless otherwise noted

The specifications surrounded by   are guaranteed by Design Engineering at  $0^{\circ}\text{C} \leq T_a \leq 60^{\circ}\text{C}$ .

### R5437L Electrical Characteristics

( $T_a = 25^{\circ}\text{C}$ )

Symbol	Item	Conditions	Min.	Typ.	Max.	Unit	Circuit (1)
$V_{DET1n}$	CELLn Overcharge Detection Voltage	Detect rising edge of supply voltage	$V_{DET1n}$	$V_{DET1n}$	$V_{DET1n}$	V	A
			<span style="border: 1px solid black; padding: 0 2px;"><math>-0.020\text{V}</math></span>		<span style="border: 1px solid black; padding: 0 2px;"><math>+0.020\text{V}</math></span>		
$V_{REL1n}$	CELLn Overcharge Release Voltage	Detect falling edge of supply voltage	$V_{REL1n}$	$V_{REL1n}$	$V_{REL1n}$	V	A
			<span style="border: 1px solid black; padding: 0 2px;"><math>-0.025\text{V}</math></span>		<span style="border: 1px solid black; padding: 0 2px;"><math>+0.025\text{V}</math></span>		
$t_{VDET1}$	Overcharge Detection Delay Time	$V_{CELLn}=3.9\text{ V}$ ( $n=2,3$ ) $V_{CELL1}=3.9\text{ V} \rightarrow 4.7\text{ V}$	$t_{VDET1}$ $\times 0.8$	$t_{VDET1}$	$t_{VDET1}$ $\times 1.2$	s	B
$t_{VREL1}$	Overcharge Release Delay Time	$V_{CELLn}=3.9\text{ V}$ ( $n=2,3$ ) $V_{CELL1}=4.7\text{ V} \rightarrow 3.9\text{ V}$	12.8	16	19.2	ms	B
$V_{SHT}$	Shutdown Detection Voltage	Detect falling edge of supply voltage	3.2	3.5	3.8	V	C
$V_{OH1}$	COUT Pch. ON Voltage 1	$I_{OH}=0\mu\text{A}, V_{CELLn} = 4.7\text{ V}$	4.0	4.7	5.4	V	D
		$I_{OH}=0\mu\text{A}, V_{CELLn} = 4.7\text{ V}$ ( $n=1$ , at 1 cell protection)		$V_{DD}$			
$V_{OH2}$	COUT Pch. ON Voltage 2	$I_{OH} = -50\mu\text{A}$ , $V_{CELLn} = 4.7\text{V}$	$V_{OH1}$ $-0.5\text{V}$	$V_{OH1}-0.1\text{V}$		V	E
$V_{OL}$	COUT Nch. ON Voltage	$I_{OL}=50\mu\text{A}, V_{CELLn}=3.9\text{ V}$		0.1	0.5	V	F
$I_{SHT}$	Shutdown Current	$V_{CELLn} = 3.1\text{ V}$			0.1	$\mu\text{A}$	G
$I_{SS}$	Supply Current	$V_{CELLn} = 3.9\text{ V}$		0.85	1.7	$\mu\text{A}$	G

### TEST CIRCUITS

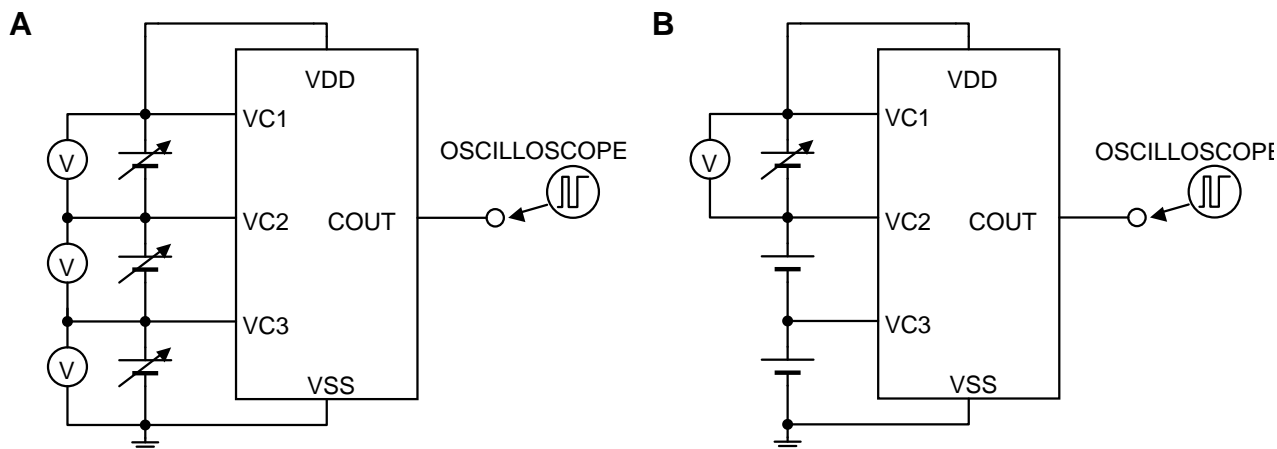

(1) Refer to TEST CIRCUITS for detail information.

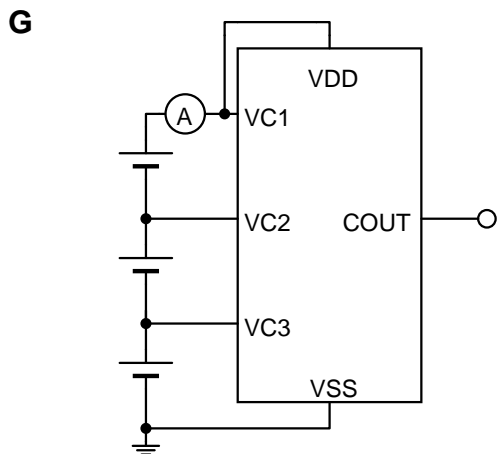
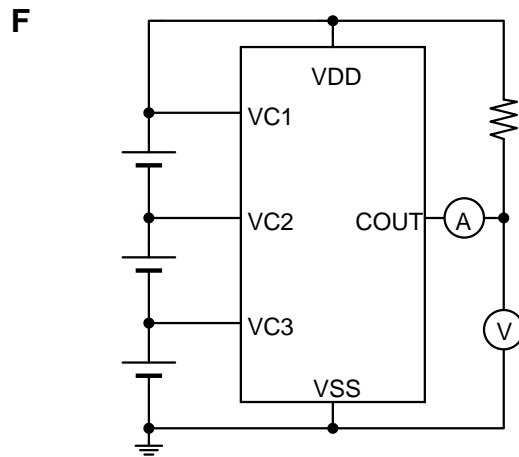
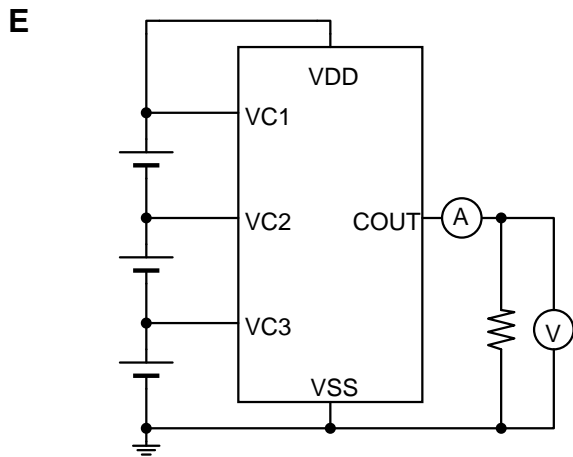
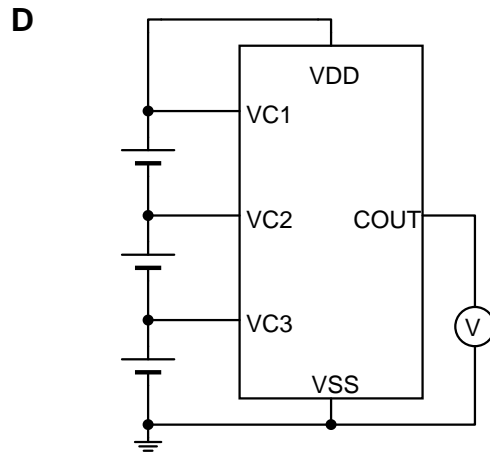
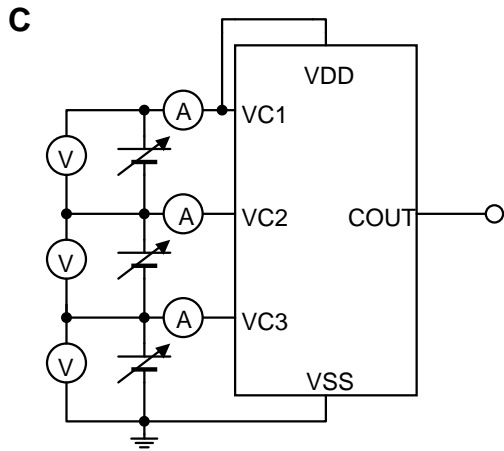



## **THEORY OF OPERATION**

### **Overcharge Detection Circuit, VD1-n (n = 1, 2, 3)**

(See the following timing chart)

While the cells are charged, the voltage between VC1 pin and VC2 pin (Cell-1 voltage), the voltage between VC2 pin and VC3 pin (Cell-2 voltage), and the voltage between VC3 pin and VSS pin (Cell-3 voltage) are supervised. If at least one of the cells' voltage becomes equal or more than the overcharge detector threshold, the overcharge is detected, and an external charge control Nch. FET turns on with COUT pin being at "H" level and by cutting a fuse on the charger path, and charge stops.

To reset the overcharge and make the COUT pin level to "L" again after detecting over-charge, in such conditions that a time when all the cells' voltages are down to a level lower than overcharge released voltage. Internal fixed output delay times for overcharge detection and release from over-charge exist. Even if one of voltage of the cells keeps its level more than the overcharge detector threshold, and output delay time passes, overcharge voltage is detected. After detecting overcharge, even if all the cell voltages become equal or less than the released voltage from overcharge, if at least one of the cells voltage becomes higher than the released voltage from overcharge within the output delay time of the release from overcharge, then overcharge is not released.

The output type of the COUT pin is CMOS output between VSS and the built-in regulator, and "H" level of COUT pin is the output voltage of the built-in regulator.

### **Shutdown Function**

The voltage between VC1 pin and VC2 pin (Cell-1 voltage), the voltage between VC2 pin and VC3 pin (Cell-2 voltage), and the voltage between VC3 pin and VSS pin (Cell-3 voltage) are supervised. If the cell voltage becomes equal or less than the shutdown detector threshold, the overcharge detector of the cell is halted, as a result, the consumption current of IC itself (Shutdown current) is extremely reduced. If at least one of the cells voltage becomes higher than the shutdown detection voltage, the shutdown detection is released.

### **Delay Shortening (DS) Function**

Applying a voltage of  $4\text{ V} \pm 0.2\text{ V}$  between VDD and VC1 can shorten the overcharge detection delay time ( $t_{\text{VDET1}}$ ) into approximately 1/90, likewise, the overcharge release delay time ( $t_{\text{VREL1}}$ ) into approximately 1/60.

# R5437L

No. EA-416-180612

## 1-cell/ 2-cell Protection Alternative

By short-circuiting between cells, this device can meet as a protection IC for 1 or 3 cells placed in series.

The following table indicates pins to short-circuit depending on protected cells.

Protected Cells	Pins to short-circuit
1-cell protection	VC1 and VC2 pins, and VC3 and VSS pins
2-cell protection	VC1 and VC2 pins, or VC3 and VSS pins

If providing other connections except above short-circuit for 1 or 2 cells protection, perform thorough evaluation using the actual devices.

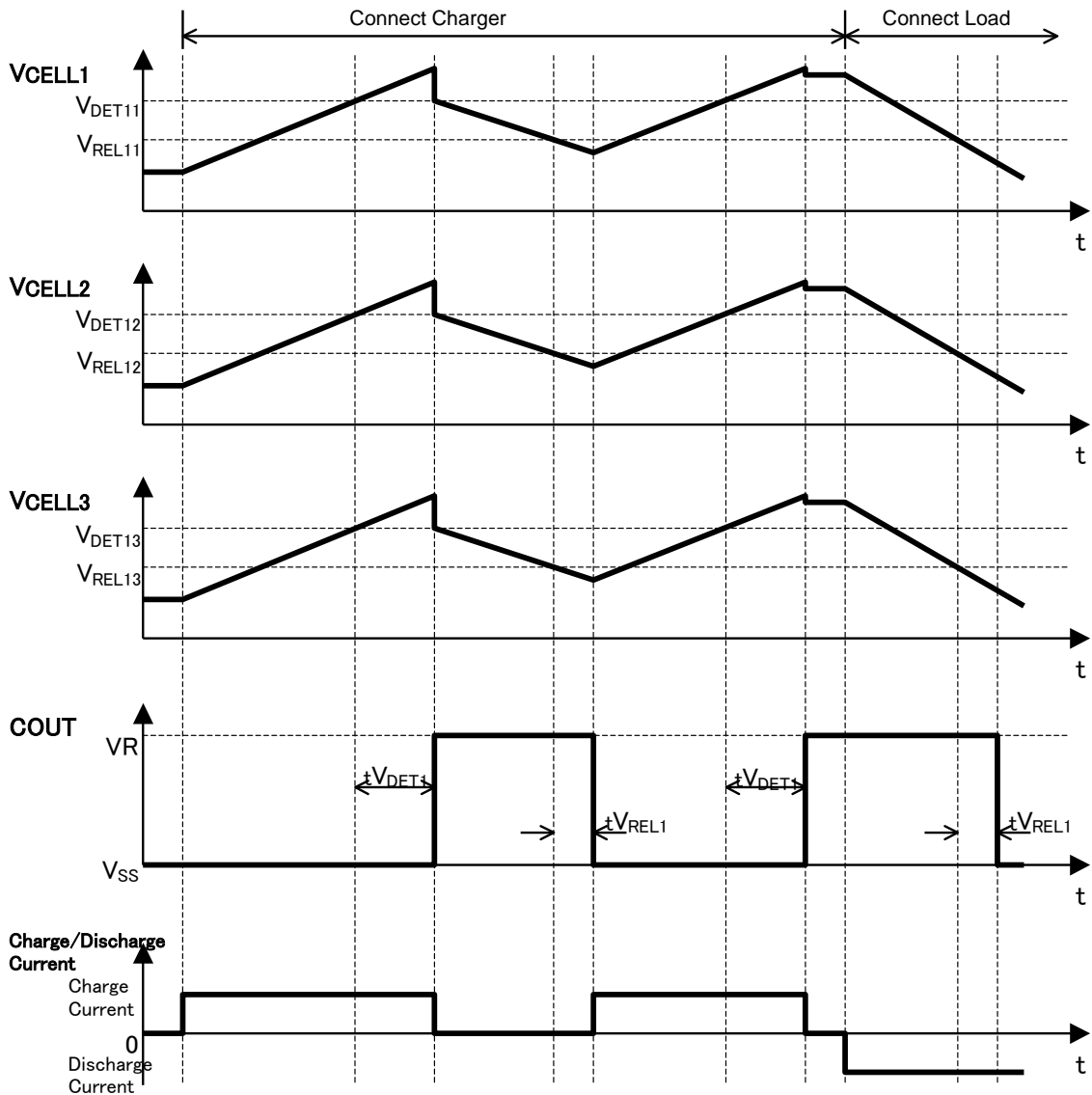

Overcharge Operation Timing Chart

## APPLICATION INFORMATION

### Typical Application Circuits in Normal Mode (CMOS Output, Active-high)

As for the order of cell's connection, connect a positive terminal of CELL1 as the end terminal. If connected another terminal, a fuse blowout might be caused by transiently "High" output of the COUT pin.

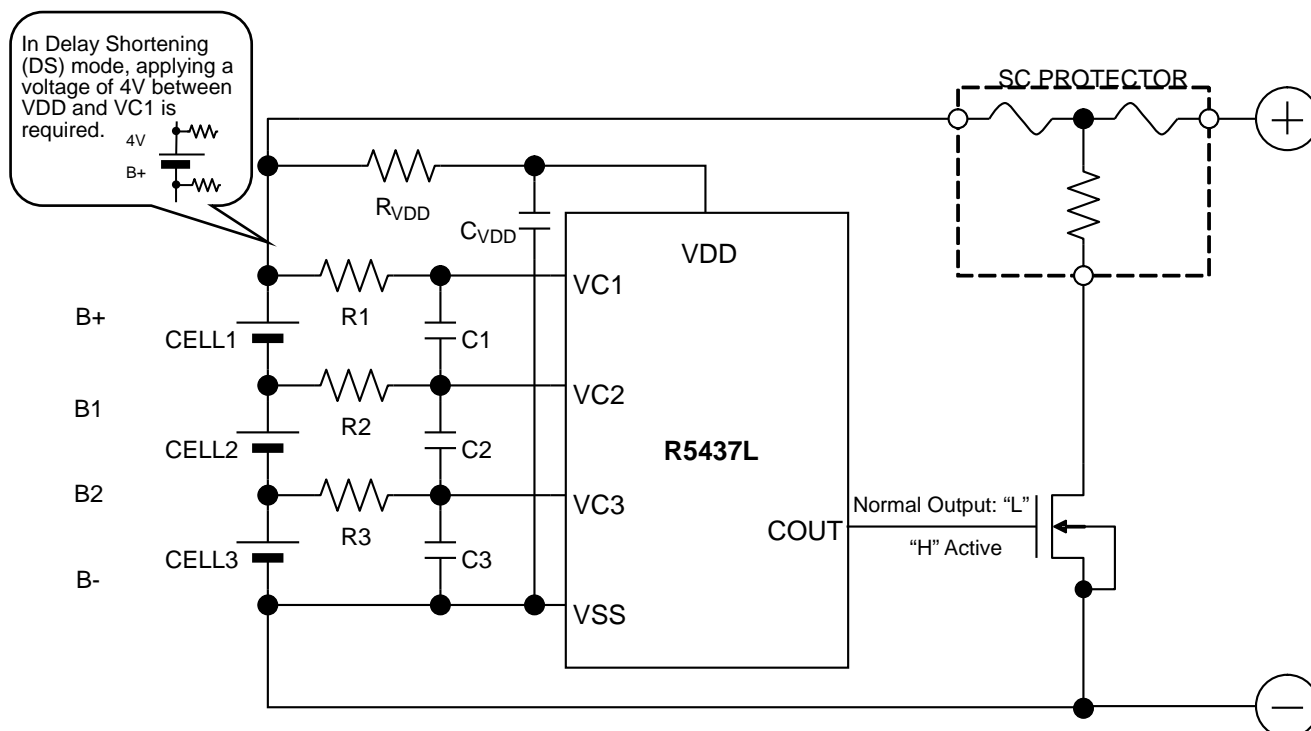

Typical Application Circuit for 3-cell Protection

# R5437L

No. EA-416-180612

In Delay Shortening (DS) mode, applying a voltage of 4V between VDD and VC1 is required.

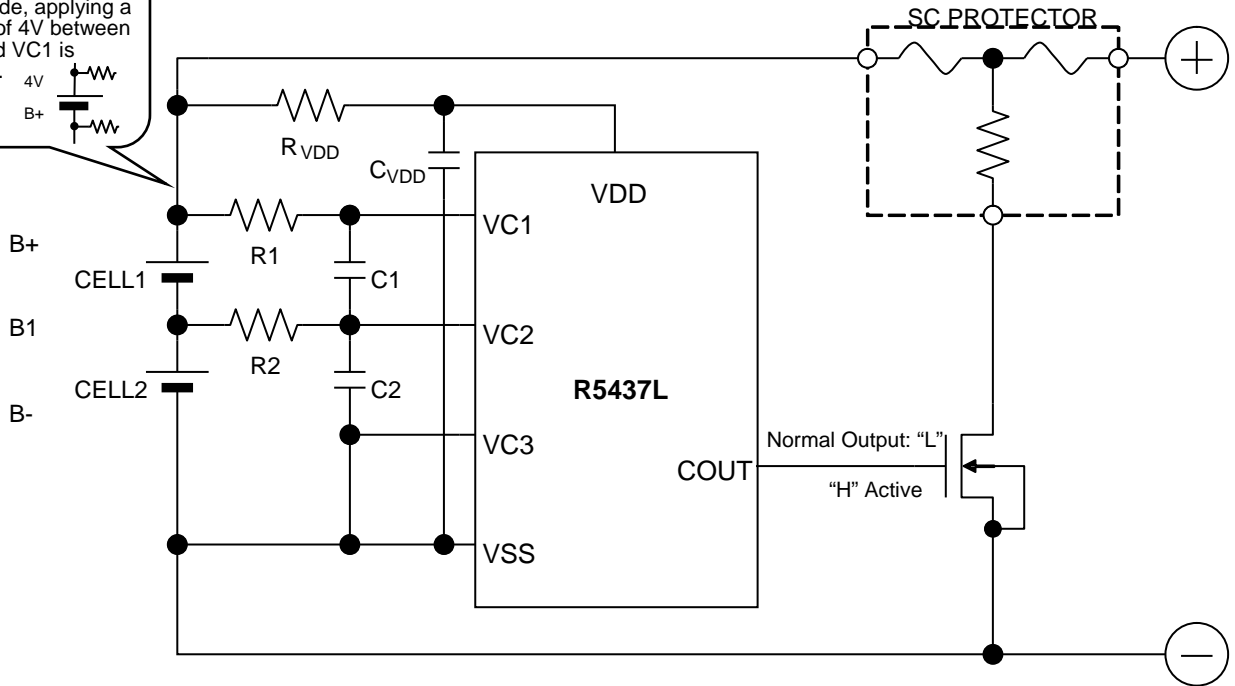

Typical Application Circuit for 2-cell Protection -1

In Delay Shortening (DS) mode, applying a voltage of 4V between VDD and VC1 is required.

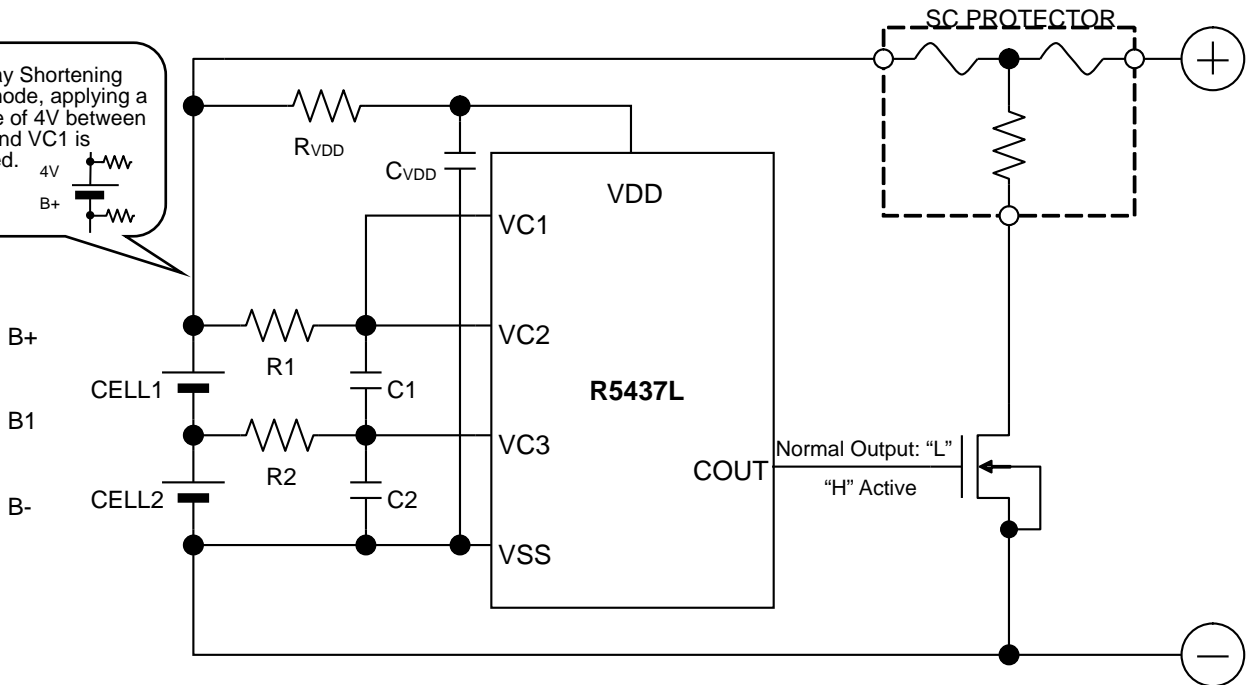

Typical Application Circuit for 2-cell Protection -2

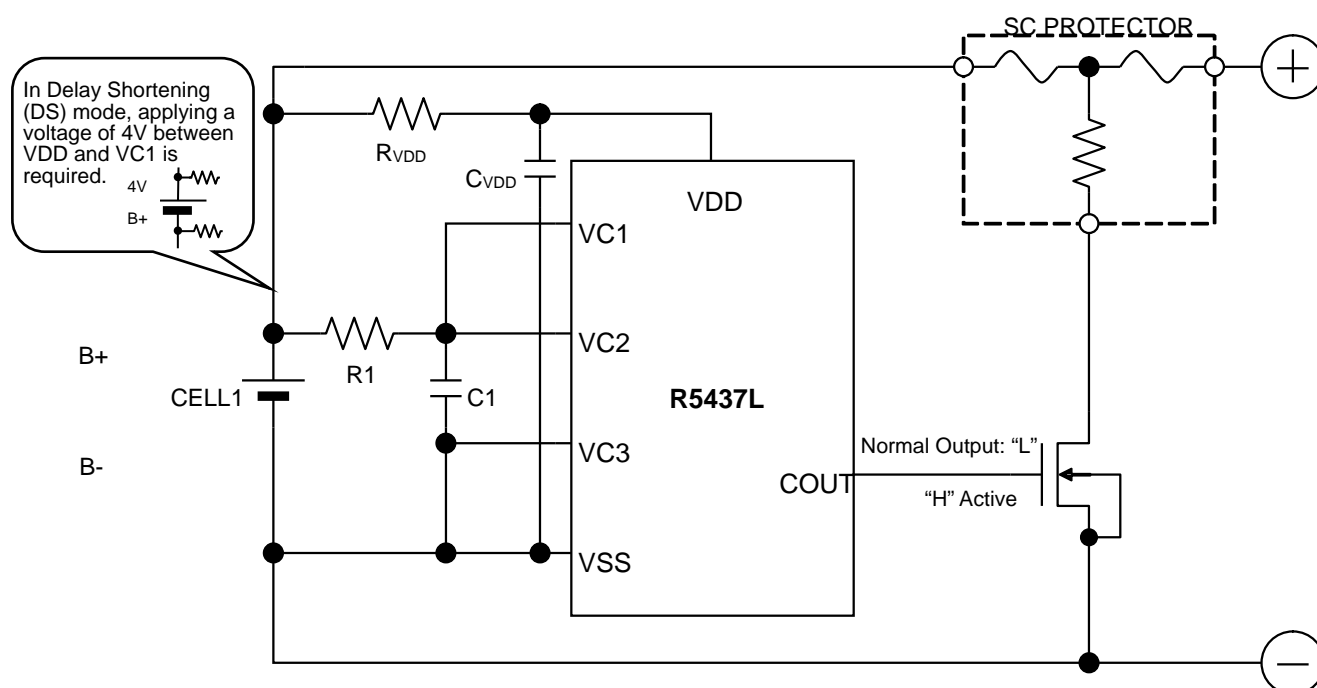

Typical Application Circuit for 1-cell Protection

## External Components

Symbol	Typ.	Unit	Range
R <sub>VDD</sub>	100	Ω	100 to 1000
R <sub>1</sub>	1000	Ω	330 to 1000
R <sub>2</sub>	1000	Ω	330 to 1000
R <sub>3</sub>	1000	Ω	330 to 1000
C <sub>VDD</sub>	0.1	μF	0.01 to 1
C <sub>1</sub>	0.1	μF	0.01 to 1
C <sub>2</sub>	0.1	μF	0.01 to 1
C <sub>3</sub>	0.1	μF	0.01 to 1

---

## R5437L

---

No. EA-416-180612

### Technical Notes on the Selection Components

- The voltage fluctuation is stabilized with  $R_{VDD}$  and  $C_{VDD}$ . If a small  $R_{VDD}$  is set, in the case of the large transient may happen to the cell voltage, by the flowing current, the IC may be unstable. If a large  $R_{VDD}$  is set, by the consumption current of the IC itself, the voltage difference between VDD pin and VC1 pin is generated, and unexpected operation may result. Therefore, the appropriate value range of  $R_{VDD}$  is from 100  $\Omega$  to 1 k $\Omega$ . To make a stable operation of the IC, the appropriate value range of  $C_{VDD}$  is from 0.01  $\mu$ F to 1.0  $\mu$ F.
- The voltage fluctuation is stabilized with R1 to R3 and C1 to C3. If a R1 to R3 is too large, by the conduction current at detection, the detector threshold may shift higher. Therefore, the appropriate value range of R1 to R3 is equal or less than 1 k $\Omega$ . To make a stable operation of the IC, the appropriate value range of C1 to C3 is 0.01  $\mu$ F or more.
- The typical application circuit diagrams are just examples. This circuit performance largely depends on the PCB layout and external components. In the actual application, fully evaluation is necessary.
- Overvoltage and the over current beyond the absolute maximum rating should not be forced to the protection IC and external components. During the time until the fuse is open after detecting overcharge, a large current may flow through the FET. Select an FET with large enough current capacity in order to endure the large current.
- To connect the SC protector, connect the SC protector to the cell must be the last.

### Contact Information for Inquiries regarding SC PROTECTOR

Dexerials Corporation (Sony Chemical & Information Device Company Ltd.)

Gate-city Osaki East Tower 8F, 1-11-2 Osaki, Shinagawa, Tokyo, 141-0032

TEL: 03-5435-3946

URL: <http://www.dexerials.jp>

## TYPICAL CHARACTERISTICS

### Part1. vs. Temperature

#### 1) CellIn Overcharge Detection Threshold vs. Temperature

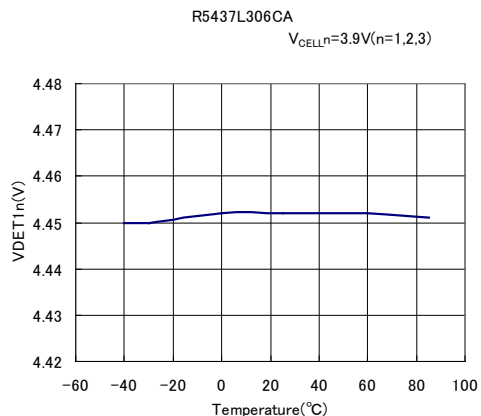

#### 2) CellIn Overcharge Release Voltage vs. Temperature

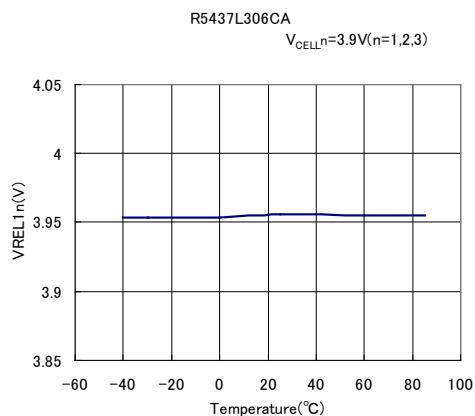

#### 3) Overcharge Output delay Time vs. Temperature

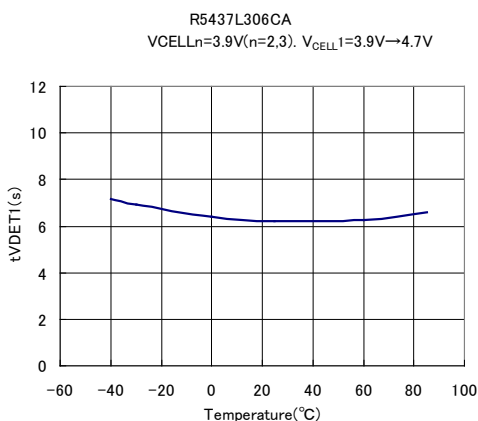
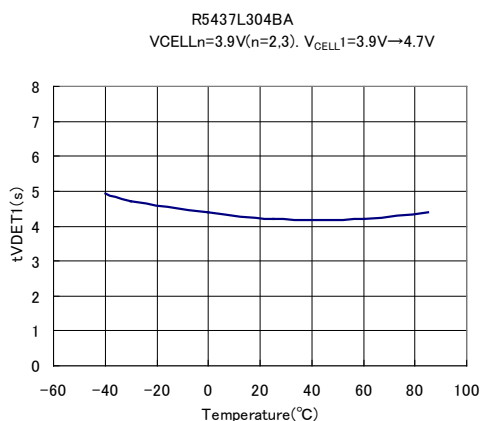

#### 4) Released Delay Time from Overcharge vs. Temperature

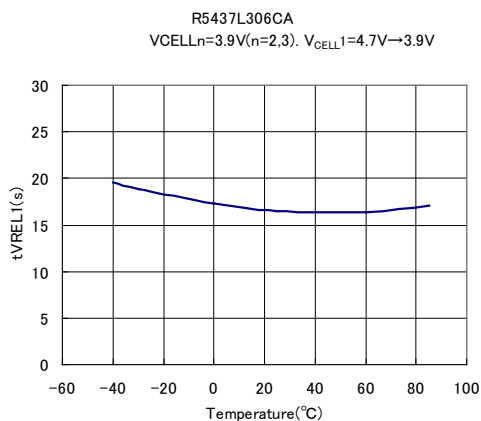

#### 5) CellIn Shutdown Threshold vs. Temperature

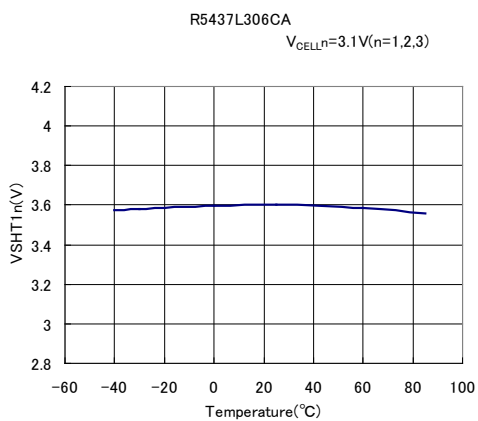

No. EA-416-180612

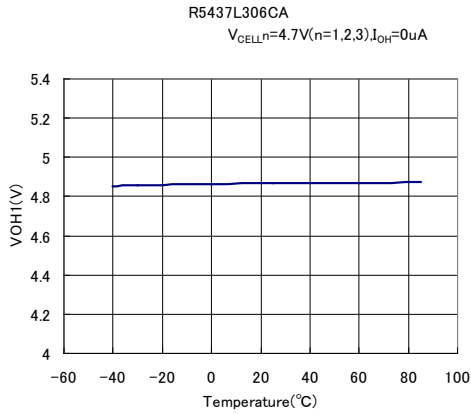
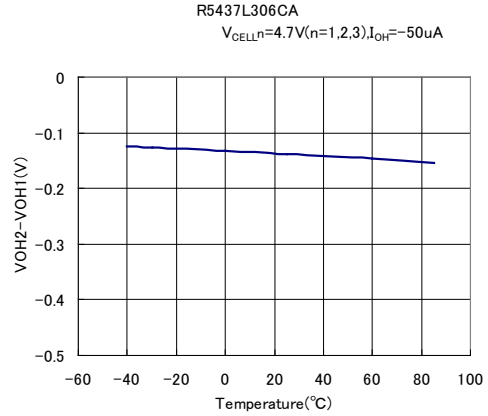
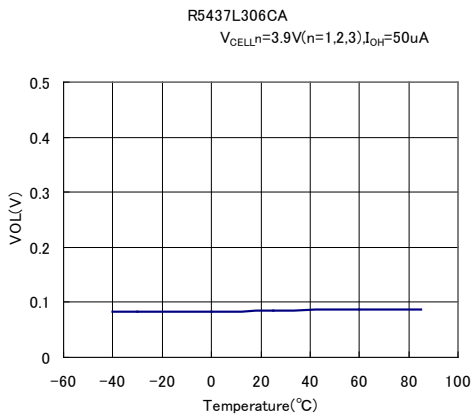
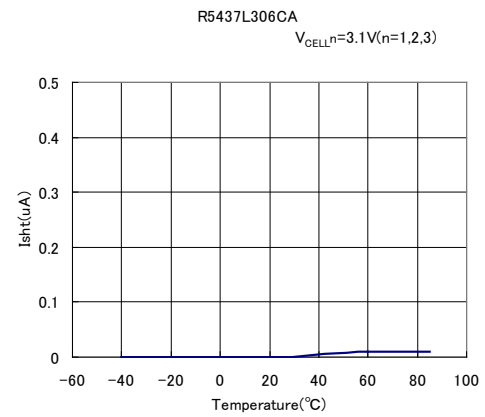
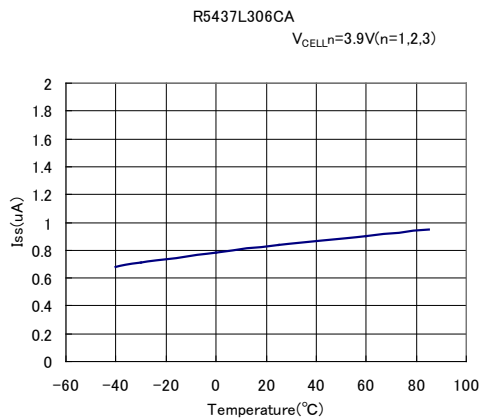
**6) COUT Pch. On Voltage (No Load) vs. Temperature****7) COUT Pch. On Voltage vs. Temperature****8) COUT Nch. On Voltage vs. Temperature****9) Shutdown Current vs. Temperature****10) Supply Current vs. Temperature**



## Part2. Supply Current vs. VDD (R5437L306CA)

### 3-cell Protection Supply Current vs. VDD

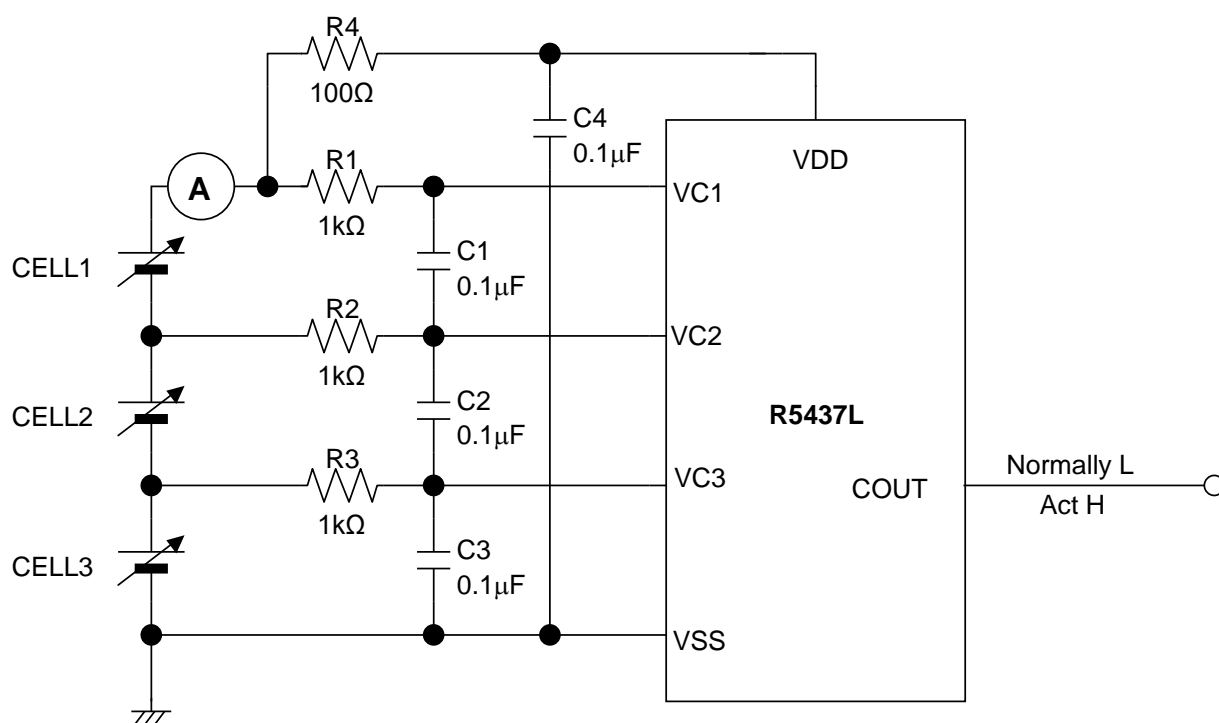
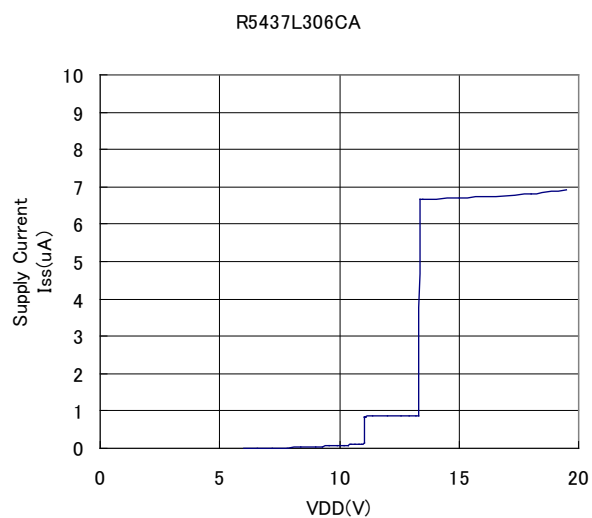

Test Circuit

# R5437L

No. EA-416-180612

## Part3. vs. External Resister Dependence (R5437L306CA) Overcharge Detection Voltage / Overcharge Release Voltage vs. R1

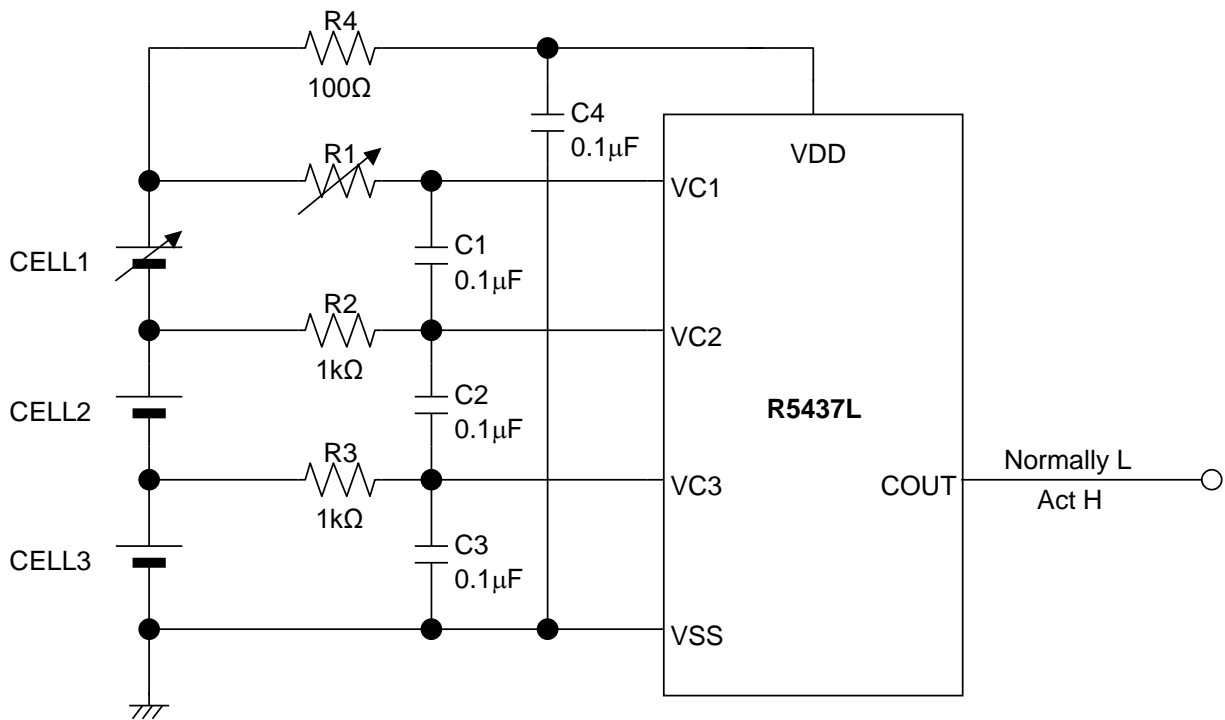
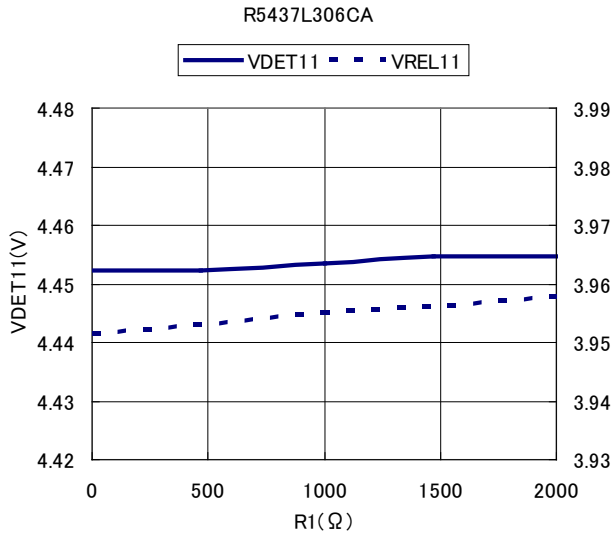

Test Circuit

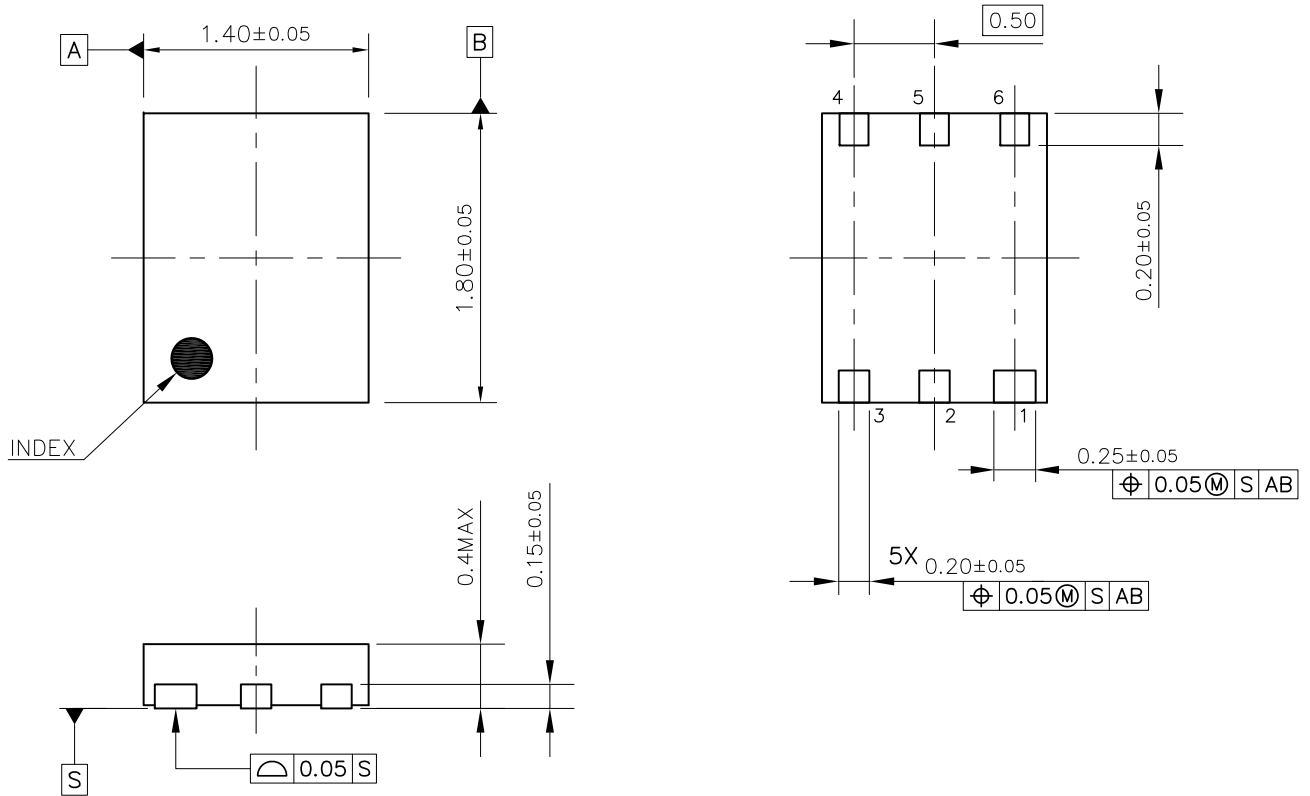

DFN1814-6C Package Dimensions (Unit: mm)



1. The products and the product specifications described in this document are subject to change or discontinuation of production without notice for reasons such as improvement. Therefore, before deciding to use the products, please refer to Ricoh sales representatives for the latest information thereon.
2. The materials in this document may not be copied or otherwise reproduced in whole or in part without prior written consent of Ricoh.
3. Please be sure to take any necessary formalities under relevant laws or regulations before exporting or otherwise taking out of your country the products or the technical information described herein.
4. The technical information described in this document shows typical characteristics of and example application circuits for the products. The release of such information is not to be construed as a warranty of or a grant of license under Ricoh's or any third party's intellectual property rights or any other rights.
5. The products listed in this document are intended and designed for use as general electronic components in standard applications (office equipment, telecommunication equipment, measuring instruments, consumer electronic products, amusement equipment etc.). Those customers intending to use a product in an application requiring extreme quality and reliability, for example, in a highly specific application where the failure or misoperation of the product could result in human injury or death (aircraft, spacevehicle, nuclear reactor control system, traffic control system, automotive and transportation equipment, combustion equipment, safety devices, life support system etc.) should first contact us.
6. We are making our continuous effort to improve the quality and reliability of our products, but semiconductor products are likely to fail with certain probability. In order to prevent any injury to persons or damages to property resulting from such failure, customers should be careful enough to incorporate safety measures in their design, such as redundancy feature, fire containment feature and fail-safe feature. We do not assume any liability or responsibility for any loss or damage arising from misuse or inappropriate use of the products.
7. Anti-radiation design is not implemented in the products described in this document.
8. The X-ray exposure can influence functions and characteristics of the products. Confirm the product functions and characteristics in the evaluation stage.
9. WLCSP products should be used in light shielded environments. The light exposure can influence functions and characteristics of the products under operation or storage.
10. There can be variation in the marking when different AOI (Automated Optical Inspection) equipment is used. In the case of recognizing the marking characteristic with AOI, please contact Ricoh sales or our distributor before attempting to use AOI.
11. Please contact Ricoh sales representatives should you have any questions or comments concerning the products or the technical information.



**Ricoh is committed to reducing the environmental loading materials in electrical devices with a view to contributing to the protection of human health and the environment.**

Ricoh has been providing RoHS compliant products since April 1, 2006 and Halogen-free products since April 1, 2012.

**RICOH** RICOH ELECTRONIC DEVICES CO., LTD.

<https://www.e-devices.ricoh.co.jp/en/>

#### Sales & Support Offices

##### **Ricoh Electronic Devices Co., Ltd.**

##### **Shin-Yokohama Office (International Sales)**

2-3, Shin-Yokohama 3-chome, Kohoku-ku, Yokohama-shi, Kanagawa, 222-8530, Japan  
Phone: +81-50-3814-7687 Fax: +81-45-474-0074

##### **Ricoh Americas Holdings, Inc.**

675 Campbell Technology Parkway, Suite 200 Campbell, CA 95008, U.S.A.  
Phone: +1-408-610-3105

##### **Ricoh Europe (Netherlands) B.V.**

##### **Semiconductor Support Centre**

Prof. W.H. Keesomlaan 1, 1183 DJ Amstelveen, The Netherlands  
Phone: +31-20-5474-309

##### **Ricoh International B.V. - German Branch**

##### **Semiconductor Sales and Support Centre**

Oberrather Strasse 6, 40472 Düsseldorf, Germany  
Phone: +49-211-6546-0

##### **Ricoh Electronic Devices Korea Co., Ltd.**

3F, Haesung Bldg, 504, Teheran-ro, Gangnam-gu, Seoul, 135-725, Korea  
Phone: +82-2-2135-5700 Fax: +82-2-2051-5713

##### **Ricoh Electronic Devices Shanghai Co., Ltd.**

Room 403, No.2 Building, No.690 Bibo Road, Pu Dong New District, Shanghai 201203,  
People's Republic of China  
Phone: +86-21-5027-3200 Fax: +86-21-5027-3299

##### **Ricoh Electronic Devices Shanghai Co., Ltd.**

##### **Shenzhen Branch**

1205, Block D (Jinlong Building), Kingkey 100, Hongbao Road, Luohu District,  
Shenzhen, China  
Phone: +86-755-8348-7600 Ext 225

##### **Ricoh Electronic Devices Co., Ltd.**

##### **Taipei office**

Room 109, 10F-1, No.51, Hengyang Rd., Taipei City, Taiwan  
Phone: +886-2-2313-1621/1622 Fax: +886-2-2313-1623

# Mouser Electronics

Authorized Distributor

Click to View Pricing, Inventory, Delivery & Lifecycle Information:

[Ricoch Electronics:](#)

[R5437L301BA-TR](#) [R5437L303CA-TR](#)

Компания «Океан Электроники» предлагает заключение долгосрочных отношений при поставках импортных электронных компонентов на взаимовыгодных условиях!

Наши преимущества:

- Поставка оригинальных импортных электронных компонентов напрямую с производств Америки, Европы и Азии, а так же с крупнейших складов мира;
- Широкая линейка поставок активных и пассивных импортных электронных компонентов (более 30 млн. наименований);
- Поставка сложных, дефицитных, либо снятых с производства позиций;
- Оперативные сроки поставки под заказ (от 5 рабочих дней);
- Экспресс доставка в любую точку России;
- Помощь Конструкторского Отдела и консультации квалифицированных инженеров;
- Техническая поддержка проекта, помощь в подборе аналогов, поставка прототипов;
- Поставка электронных компонентов под контролем ВП;
- Система менеджмента качества сертифицирована по Международному стандарту ISO 9001;
- При необходимости вся продукция военного и аэрокосмического назначения проходит испытания и сертификацию в лаборатории (по согласованию с заказчиком);
- Поставка специализированных компонентов военного и аэрокосмического уровня качества (Xilinx, Altera, Analog Devices, Intersil, Interpoint, Microsemi, Actel, Aeroflex, Peregrine, VPT, Syfer, Eurofarad, Texas Instruments, MS Kennedy, Miteq, Cobham, E2V, MA-COM, Hittite, Mini-Circuits, General Dynamics и др.);

Компания «Океан Электроники» является официальным дистрибьютором и эксклюзивным представителем в России одного из крупнейших производителей разъемов военного и аэрокосмического назначения «JONHON», а так же официальным дистрибьютором и эксклюзивным представителем в России производителя высокотехнологичных и надежных решений для передачи СВЧ сигналов «FORSTAR».



## JONHON

«JONHON» (основан в 1970 г.)

Разъемы специального, военного и аэрокосмического назначения:

(Применяются в военной, авиационной, аэрокосмической, морской, железнодорожной, горно- и нефтедобывающей отраслях промышленности)

«FORSTAR» (основан в 1998 г.)

ВЧ соединители, коаксиальные кабели,  
кабельные сборки и микроволновые компоненты:

(Применяются в телекоммуникациях гражданского и специального назначения, в средствах связи, РЛС, а так же военной, авиационной и аэрокосмической отраслях промышленности).



Телефон: 8 (812) 309-75-97 (многоканальный)

Факс: 8 (812) 320-03-32

Электронная почта: [ocean@oceanchips.ru](mailto:ocean@oceanchips.ru)

Web: <http://oceanchips.ru/>

Адрес: 198099, г. Санкт-Петербург, ул. Калинина, д. 2, корп. 4, лит. А