



Is Now Part of



ON Semiconductor®

To learn more about ON Semiconductor, please visit our website at
www.onsemi.com

Please note: As part of the Fairchild Semiconductor integration, some of the Fairchild orderable part numbers will need to change in order to meet ON Semiconductor's system requirements. Since the ON Semiconductor product management systems do not have the ability to manage part nomenclature that utilizes an underscore (_), the underscore (_) in the Fairchild part numbers will be changed to a dash (-). This document may contain device numbers with an underscore (_). Please check the ON Semiconductor website to verify the updated device numbers. The most current and up-to-date ordering information can be found at www.onsemi.com. Please email any questions regarding the system integration to Fairchild_questions@onsemi.com.

ON Semiconductor and the ON Semiconductor logo are trademarks of Semiconductor Components Industries, LLC dba ON Semiconductor or its subsidiaries in the United States and/or other countries. ON Semiconductor owns the rights to a number of patents, trademarks, copyrights, trade secrets, and other intellectual property. A listing of ON Semiconductor's product/patent coverage may be accessed at www.onsemi.com/site/pdf/Patent-Marking.pdf. ON Semiconductor reserves the right to make changes without further notice to any products herein. ON Semiconductor makes no warranty, representation or guarantee regarding the suitability of its products for any particular purpose, nor does ON Semiconductor assume any liability arising out of the application or use of any product or circuit, and specifically disclaims any and all liability, including without limitation special, consequential or incidental damages. Buyer is responsible for its products and applications using ON Semiconductor products, including compliance with all laws, regulations and safety requirements or standards, regardless of any support or applications information provided by ON Semiconductor. "Typical" parameters which may be provided in ON Semiconductor data sheets and/or specifications can and do vary in different applications and actual performance may vary over time. All operating parameters, including "Typicals" must be validated for each customer application by customer's technical experts. ON Semiconductor does not convey any license under its patent rights nor the rights of others. ON Semiconductor products are not designed, intended, or authorized for use as a critical component in life support systems or any FDA Class 3 medical devices or medical devices with a same or similar classification in a foreign jurisdiction or any devices intended for implantation in the human body. Should Buyer purchase or use ON Semiconductor products for any such unintended or unauthorized application, Buyer shall indemnify and hold ON Semiconductor and its officers, employees, subsidiaries, affiliates, and distributors harmless against all claims, costs, damages, and expenses, and reasonable attorney fees arising out of, directly or indirectly, any claim of personal injury or death associated with such unintended or unauthorized use, even if such claim alleges that ON Semiconductor was negligent regarding the design or manufacture of the part. ON Semiconductor is an Equal Opportunity/Affirmative Action Employer. This literature is subject to all applicable copyright laws and is not for resale in any manner.

FDMF4061 – High Performance 60V Smart Power Stage Module

Features

- Compact size – 6.0 mm x 7.5 mm PQFN
- High current handling: 25A
- Next Generation 60V Power MOSFETs:
 - Typ. $R_{DS(on)}=2.4(HS) / 2.4(LS)$ m Ω at $V_{GS}=10V, I_D=25A$
- Wide driver power supply voltage range: 10V to 20V
- Internal pull-down resistors for PWM inputs (HI,LI)
- Short PWM propagation delays
- Under-voltage lockout (UVLO)
- Fully optimized system efficiency
- High performance low profile package
- Integrated 60V Half-Bridge gate driver
- Fairchild 60V PowerTrench® MOSFETs for clean switching waveforms and reduced ringing
- Low Inductance and low resistance packaging for minimal operating power losses
- Fairchild green packaging and RoHS compliant
- Reduced EMI due to low side flip-chip MOSFET

General Description

The FDMF4061 is a compact 60V Smart Power Stage (SPS) module that is a fully optimized for use in high current switching applications. The FDMF4061 module integrates a driver IC plus two N-channel Power MOSFETs into a thermally enhanced, 6.0 mm x 7.5 mm PQFN package. The PQFN packaging provides very low package inductance and resistance improving the current handling capability and performance of the part. With an integrated approach, the complete switching power stage is optimized with regards to driver and MOSFET dynamic performance, system parasitic inductance, and Power MOSFET $R_{DS(ON)}$. The FDMF4061 uses Fairchild's high performance PowerTrench™ MOSFET technology, which reduces high voltage and current stresses in switching applications. The driver IC features a low delay times and matched PWM input propagation delays, which further enhance the performance of the part.

Applications

- Motor Drives (Power tools & Drowns etc.)
- Telecom Half / Full - Bridge DC-DC converters
- Buck-Boost Converters
- High-current DC-DC Point of Load (POL) converters.

Application Diagram

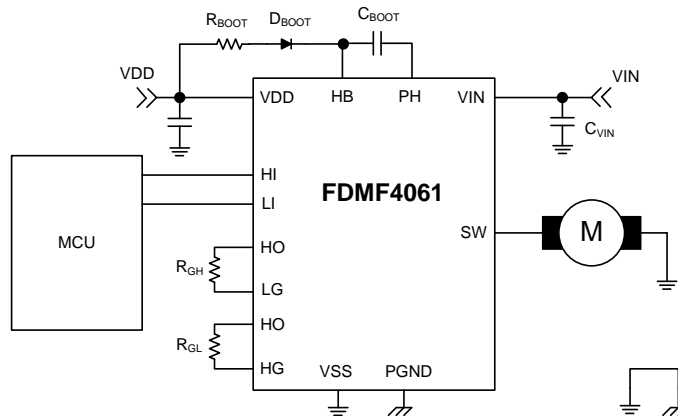

Ordering Information

Part Number	Current Rating [A]	Input Voltage [V]	Frequency Max [kHz]	Device Marking
FDMF4061	25	60	200	FDMF4061

Functional Block Diagram

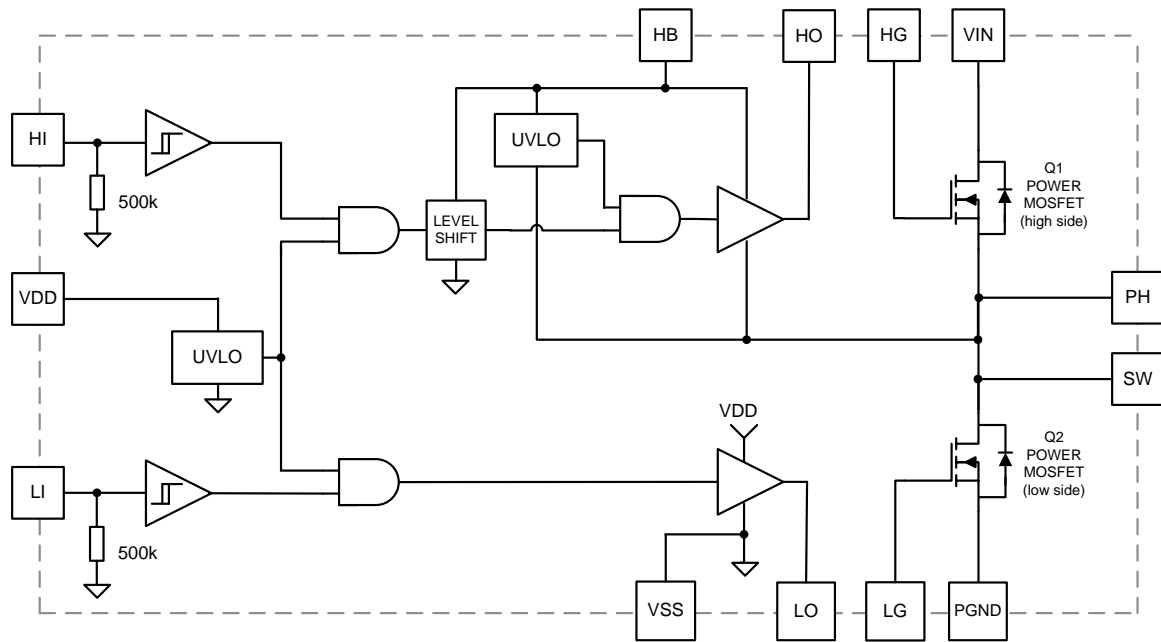

Figure 1. Functional Block Diagram

Pin Configuration

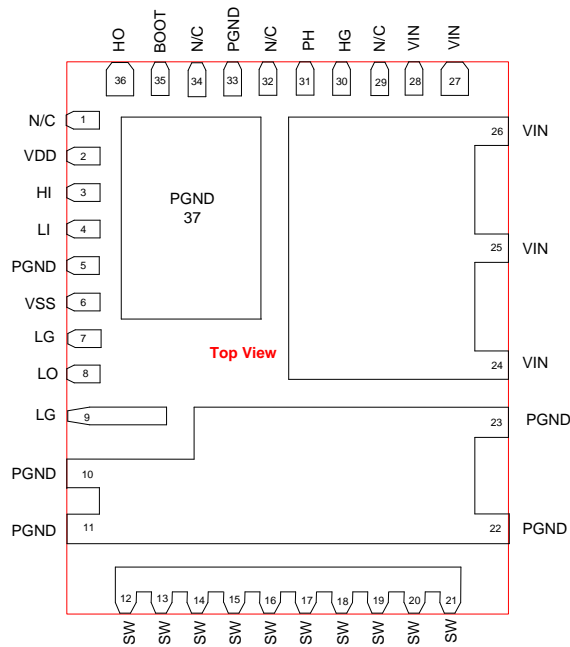

Figure 2. Pin Configuration (6.0mm x 7.5mm Package)

Pin Definitions

Pin	Name	Function
1, 29, 32, 34	N/C	No connect
2	VDD	Power supply input for low-side gate drive and bootstrap diode. Bypass this pin to VSS with a low impedance capacitor.
3	HI	High-side PWM input.
4	LI	Low-side PWM input.
5, 10,11, 22, 23, 33, 37	PGND	Power return for the power stage. Package header, pin 37 and PGND are internally fused (shorted).
6	VSS	Analog ground for driver IC analog circuits.
7,9	LG	Low-side MOSFET gate.
8	LO	Low-side gate drive output.
12-21	SW	Switching node junction between high-side and Low-side MOSFETs.
24-28	VIN	Power input for the power stage. Bypass this pin to PGND with low impedance capacitor.
30	HG	High-side MOSFET gate.
31	PH	High-side source connection (SW node) for the bootstrap capacitor.
35	HB	Bootstrap supply for high-side driver. Bypass this pin to PH with low impedance capacitor.
36	HO	High-side gate drive output.

Table 1. Pin Definitions

Typical Application Diagram

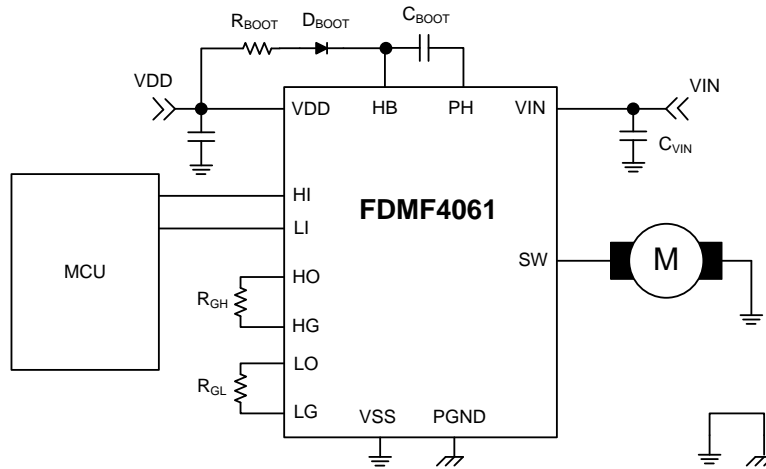

Figure 3. Half-Bridge DC Motor

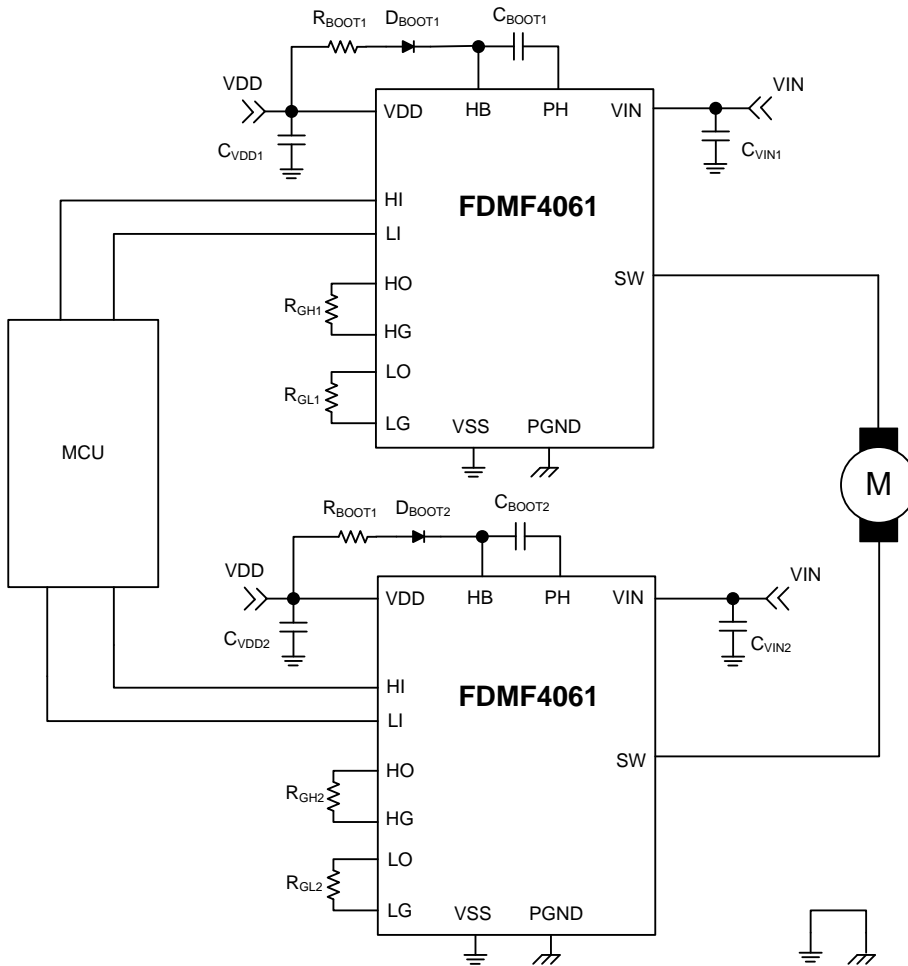

Figure 4. Full-Bridge DC Motor

Typical Application Diagram (Continued)

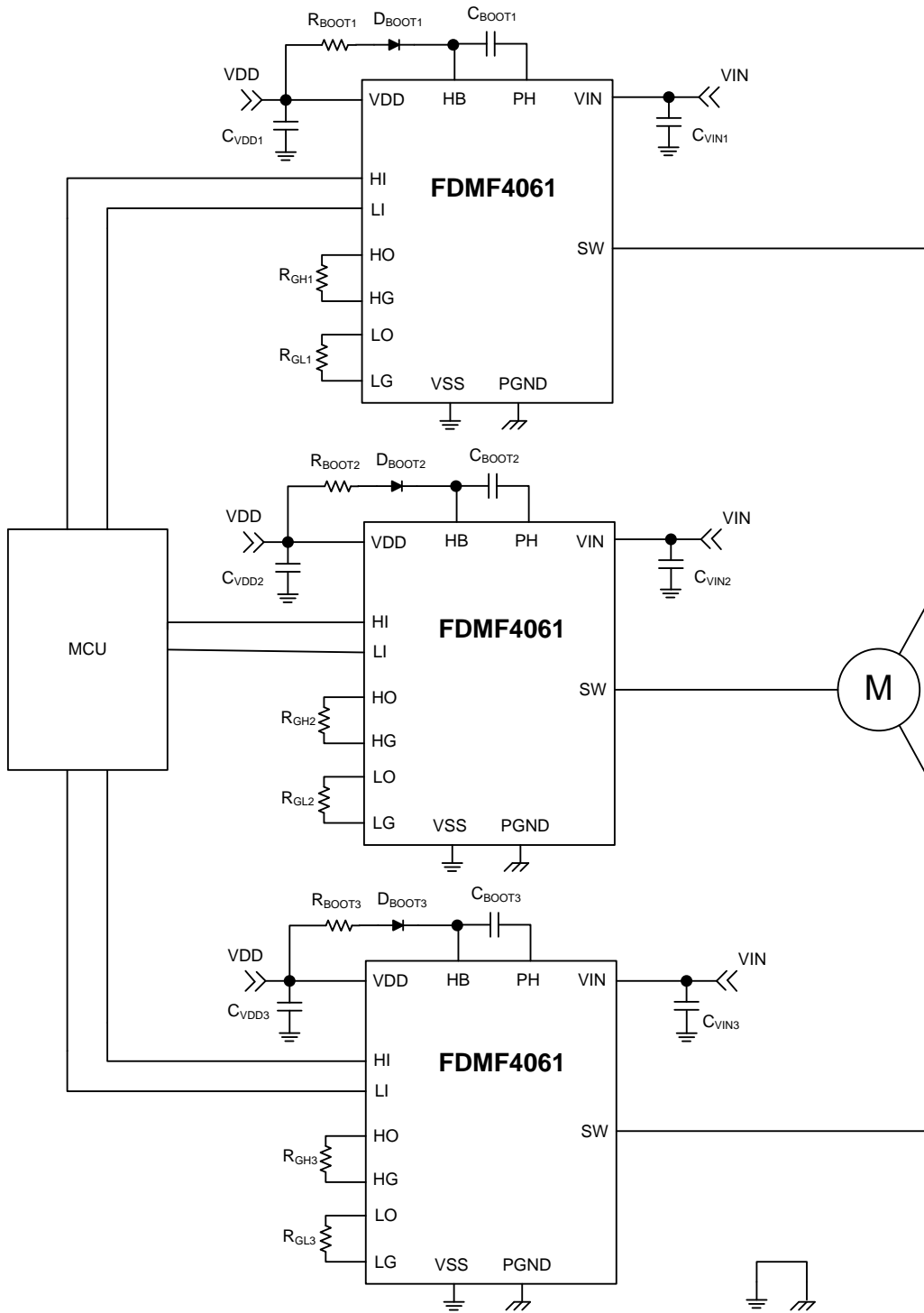

Figure 5. 3-Phase DC Motor

Typical Application Diagram (Continued)

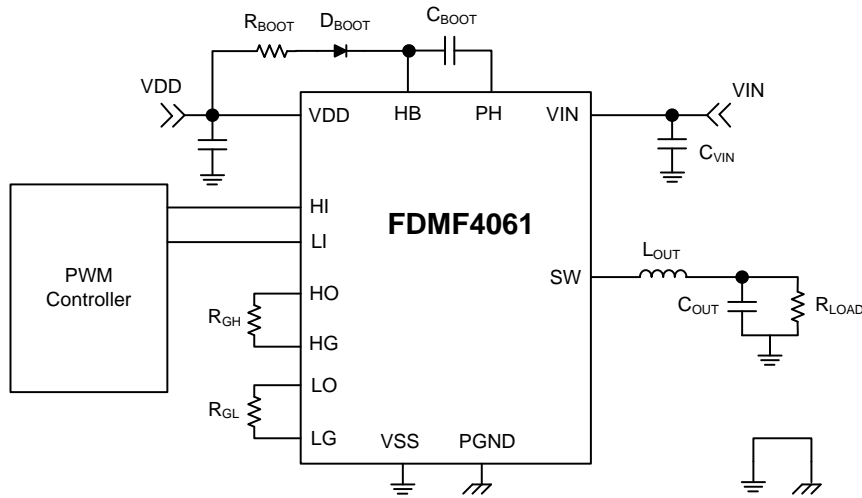

Figure 6. Buck Converter

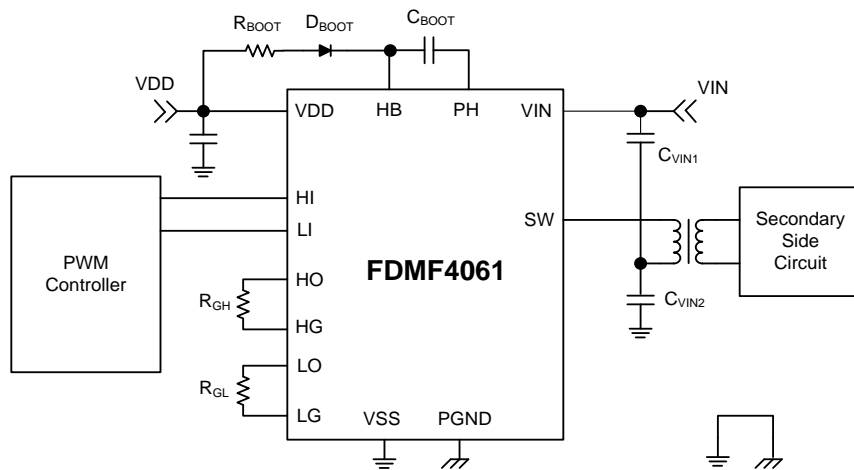

Figure 7. Half-Bridge Converter

Typical Application Diagram (Continued)

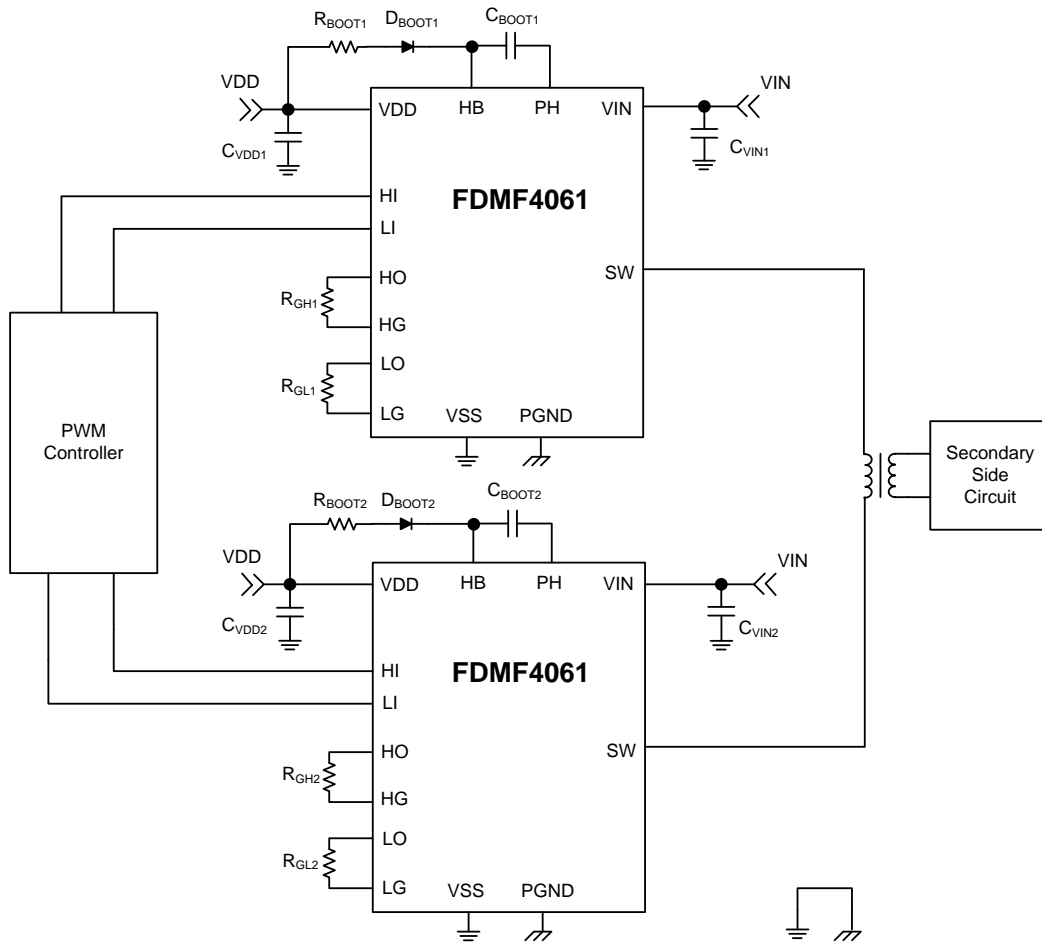

Figure 8. Full-Bridge Converter

Absolute Maximum Ratings

The "Absolute Maximum Ratings" are those values beyond which the safety of the device cannot be guaranteed. The device should not be operated at these limits. The parametric values defined in the Electrical Characteristics tables are not guaranteed at the absolute maximum ratings. The "Recommended Operating Conditions" table defines the conditions for actual device operation. Thermal resistance rating is measured under board mounted and still air conditions.

Symbol	Parameter		Min.	Max.	Unit
V _{IN}	Power Stage Supply Voltage	Referenced to VSS	-0.3	60	V
V _{PH}	PH Voltage	Referenced to VSS	V _{HB} -25	V _{HB} +0.3	V
V _{DD}	Driver Supply Voltage	Referenced to VSS	-0.3	25	V
V _{HB}	Bootstrap to VSS	Referenced to VSS,	-0.3	85	V
V _{LI} , V _{HI}	Gate drive Input signals	Referenced to VSS	-0.3	V _{DD} + 0.3V	V
V _{HO}	High Side driver output	Referenced to PHASE	V _{PH} - 0.3V	V _{BOOT} + 0.3V	V
V _{LO}	Low Side driver output	Referenced to VSS	- 0.3	V _{DD} + 0.3V	V
V _{HG}	High Side MOSFET gate	Referenced to PHASE	-26	28	V
V _{LG}	Low Side MOSFET gate	Referenced to VSS	-26	28	V
Θ _{JA}	Junction to Ambient Thermal Resistance – Q1 ⁽¹⁾		-	17	°C/W
	Junction to Ambient Thermal Resistance – Q2 ⁽¹⁾		-	15	°C/W
T _J	Junction Temperature		-	150	°C
T _{STG}	Storage Temperature		-40	150	°C

Table 2. Module Absolute Maximum ratings

(1) Mounted on a 4-layer FR4 PCB with a dissipating copper surface on the top side of 49 cm², 2oz.

Recommended Operating Conditions

Symbol	Parameters	Test Condition	Min	Max	Unit
V _{IN}	Power Stage Supply Voltage		3	50	V
V _{DD}	Driver Supply Voltage		10	20	V
V _{SW} , V _{PH}	SW or PHASE	DC	-0.3	60	V
		Repetitive Pulse (< 20ns, 10uJ)	6-V _{DD}	60	V
V _{HB}	Voltage on HB	Reference to PH	V _{PH} + 10	V _{PH} + 20	V
dV _{SW} /dt	Voltage Slew Rate on SW		-	50	V/ns
T _J	Operating Temperature		-40	125	°C

Table 3. Module Recommended Operating Conditions

Electrical Specifications:

$V_{DD}=V_{HB}=15V$, $V_{SW}=V_{SS}=0V$, $V_{IN}=30V$, $T_J=+25^{\circ}C$ unless otherwise noted.

Symbol	Parameter	Condition	Min.	Typ.	Max.	Unit
Supply Currents						
I_{INQ}	Power Stage Quiescent Current	LI = HI = 0V	-	-	1	uA
I_{DDQ}	Driver Quiescent Current	LI = HI = 0V	-	67	180	uA
I_{DDO}	VDD operating current	$F_{SW} = 20kHz$	-	0.3	0.6	mA
		$F_{SW} = 200kHz$	-	2.1	4.2	mA
I_{HBQ}	BOOT Quiescent current	LI = HI = 0V	-	38	120	uA
I_{HBO}	BOOT Operating current	$F_{SW} = 20kHz$	-	0.3	0.6	mA
		$F_{SW} = 200kHz$	-	2.4	4.8	mA
Under-Voltage Protection						
V_{DDR}, V_{HBR}	UVLO rising threshold	V_{DD} or $V_{HB}-V_{PH}$ rising threshold	8.2	9.5	10.0	V
V_{DDF}, V_{HBF}	UVLO falling threshold	V_{DD} or $V_{HB}-V_{PH}$ falling Threshold	7.6	8.9	9.6	V
V_{DDH}	UVLO Hysteresis	V_{DD} Hysteresis	-	0.6	-	V
t_{D_POR}	POR delay to Enable IC	UVLO rising to internal PWM enable	-	-	10	us
Control Inputs (TTL: LI, HI)						
V_{IL}	Low Level Input Voltage	$V_{DD} = 10V$ to $20V$	1.2	-	-	V
V_{IH}	High Level Input Voltage		-	-	2.9	V
V_{HYS}	Input Voltage Hysteresis		-	1.0	-	V
R_{IN}	Input Pull-Down Resistance		-	468	-	k Ω
PWM input (HI,LI)						
t_{LPLH}	LI to LO Propagation Delays	LI Low \rightarrow HIGH to LO Low \rightarrow HIGH, V_{IH} to 10% LG	100	153	300	ns
t_{LPHL}		LI High \rightarrow Low to LO High \rightarrow Low, V_{IL} to 90% LG	100	208	300	ns
t_{HPLH}	HI to HO Propagation Delays	HI Low \rightarrow HIGH to HO Low \rightarrow HIGH, V_{IH} to 10% HG-PH	100	170	300	ns
t_{HPHL}		HI High \rightarrow Low to HO High \rightarrow Low, V_{IL} to 90% HG-PH	100	205	300	ns
MT	Delay matching, HS and LS turn-on/off		-	-	50	ns
t_{PW}	Minimum Input Pulse Width that Changes the Output	LI/HI Rising to Vth of Q1,Q2 $R_G=0\Omega$		75		ns
		LI/HI Falling to Vth of Q1,Q2 $R_G=0\Omega$		130		ns
High-Side Driver (HDRV) (VDD = VHB = 15V)						
I_{SOURCE_HO}	Output Sourcing Peak current	$V_{HO}=0V$	250	350	-	mA
I_{SINK_HO}	Output Sinking Peak current	$V_{HO}=15V$	500	650	-	mA
t_{R_HG}	Rise Time	GH=10% to 90%, $R_{GH}=0\Omega$	-	356	711	ns
t_{F_HG}	Fall Time	GH=90% to 10%, $R_{GH}=0\Omega$	-	151	302	ns
Low-Side Driver (LDRV) (VDD = VHB = 15V)						
I_{SOURCE_LO}	Output Sourcing Peak current	$V_{LO}=0V$	250	350	-	mA
I_{SINK_LO}	Output Sinking Peak current	$V_{LO}=15V$	500	650	-	mA
t_{R_LG}	Rise Time	GL=10% to 90%, $R_{GL}=0\Omega$	-	346	692	ns
t_{F_LG}	Fall Time	GL=90% to 10%, $R_{GL}=0\Omega$	-	142	283	ns

Table 4. Module Electrical Specifications

Power MOSFET specifications (FDMF4061)

$T_J = +25^\circ\text{C}$ unless otherwise noted.

Symbol	Parameter	Condition	Min.	Typ.	Max.	Unit
High Side MOSFET, Q1						
BV_{DSS}	Drain-Source Breakdown Voltage	$I_{DS}=250\mu\text{A}, V_{GS}=0\text{V}$	60	-	-	V
I_{DSS}	Zero Gate Voltage Drain Current	$V_{DS}=48\text{V}, V_{GS}=0\text{V}$	-	-	1	μA
I_{GSS}	Gate-Source Leakage Current	$V_{DS}=0\text{V}, V_{GS}=\pm 20\text{V}$	-	-	100	nA
$V_{GS(th)}$	Gate-Source Threshold Voltage	$V_{DS}=V_{GS}, I_{DS}=250\mu\text{A}$	2.5	3.7	4.5	V
$R_{DS(ON)}$	Drain –Source On-Resistance	$V_{GS}=10\text{V}, I_{DS}=25\text{A}$	-	2.4	3.2	$\text{m}\Omega$
Q_G	Total Gate Charge	$V_{GS}=0\text{V to }10\text{V}, V_{DD}=30\text{V}, I_{DS}=25\text{A}$	-	56	78	nC
Q_{GS}	Gate-Source Charge		-	23	-	nC
Q_{GD}	Gate-Drain "Miller" Charge		-	8	-	nC
Q_{OSS}	Total Output Charge		-	65	-	nC
R_G	Series Gate Resistance		-	1.0	-	Ω
Drain-Source Diode Characteristics						
V_{SD}	Source to Drain Forward Voltage	$V_{HG}-V_{PH}=0\text{V}, I_{SD} = 2\text{A}$	-	0.7	1.2	V
		$V_{HG}-V_{PH}=0\text{V}, I_{SD} = 25\text{A}$	-	0.8	1.3	
t_{RR}	Reverse Recovery Time	$I_F = 25\text{A}, di_F/dt = 100\text{A}/\mu\text{s}$	-	58	117	ns
Q_{RR}	Reverse Recovery Charge		-	51	103	nC
t_{RR}	Reverse Recovery Time	$I_F = 25\text{A}, di_F/dt = 300\text{A}/\mu\text{s}$	-	44	88	ns
Q_{RR}	Reverse Recovery Charge		-	79	158	nC
Low Side MOSFET, Q2						
BV_{DSS}	Drain-Source Breakdown Voltage	$I_{DS}=250\mu\text{A}, V_{GS}=0\text{V}$	60	-	-	V
I_{DSS}	Zero Gate Voltage Drain Current	$V_{DS}=48\text{V}, V_{GS}=0\text{V}$	-	-	1	μA
I_{GSS}	Gate-Source Leakage Current	$V_{DS}=0\text{V}, V_{GS}=\pm 20\text{V}$	-	-	100	nA
$V_{GS(th)}$	Gate-Source Threshold Voltage	$V_{DS}=V_{GS}, I_{DS}=250\mu\text{A}$	2.5	3.5	4.5	V
$R_{DS(ON)}$	Drain –Source On-Resistance	$V_{GS}=10\text{V}, I_{DS}=25\text{A}$	-	2.4	3.2	$\text{m}\Omega$
Q_G	Total Gate Charge	$V_{GS}=0\text{V to }10\text{V}, V_{DD}=30\text{V}, I_{DS}=25\text{A}$	-	59	82	nC
Q_{GS}	Gate-Source Charge		-	25	-	nC
Q_{GD}	Gate-Drain "Miller" Charge		-	11	-	nC
Q_{OSS}	Total Output Charge		-	63	-	nC
R_G	Series Gate Resistance		-	1.0	-	Ω
Drain-Source Diode Characteristics						
V_{SD}	Source to Drain Forward Voltage	$V_{HG}-V_{PH}=0\text{V}, I_{SD} = 2\text{A}$	-	0.7	1.2	V
		$V_{HG}-V_{PH}=0\text{V}, I_{SD} = 25\text{A}$	-	0.8	1.3	
t_{RR}	Reverse Recovery Time	$I_F = 25\text{A}, di_F/dt = 100\text{A}/\mu\text{s}$	-	57	114	ns
Q_{RR}	Reverse Recovery Charge		-	52	105	nC
t_{RR}	Reverse Recovery Time	$I_F = 25\text{A}, di_F/dt = 300\text{A}/\mu\text{s}$	-	43	86	ns
Q_{RR}	Reverse Recovery Charge		-	81	161	nC

Table 5. FDMF4061 MOSFET Electrical Specifications

Typical Performance Characteristics

T_j = 25°C unless otherwise noted.

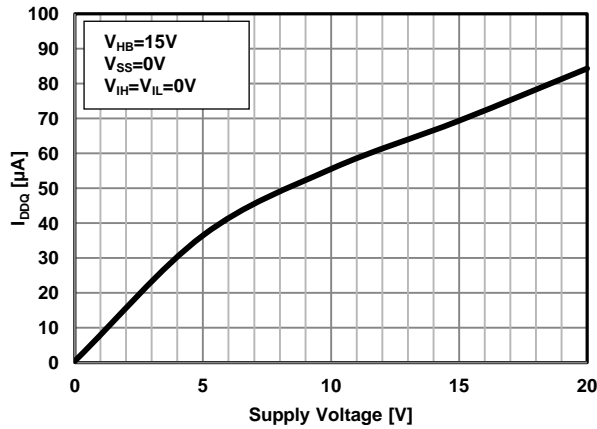

Figure 9. I_{DDQ} vs. Supply Voltage(V_{DD})

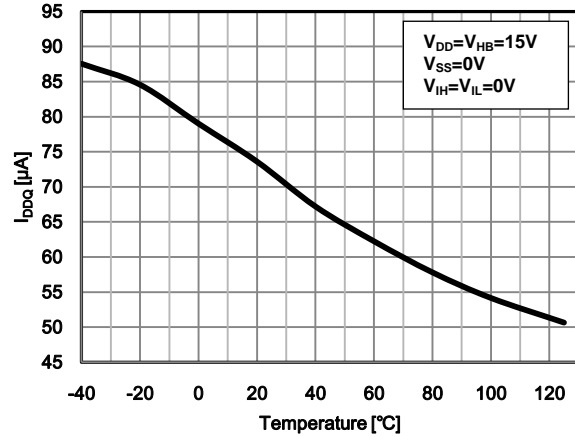

Figure 10. I_{DDQ} vs. Temp.

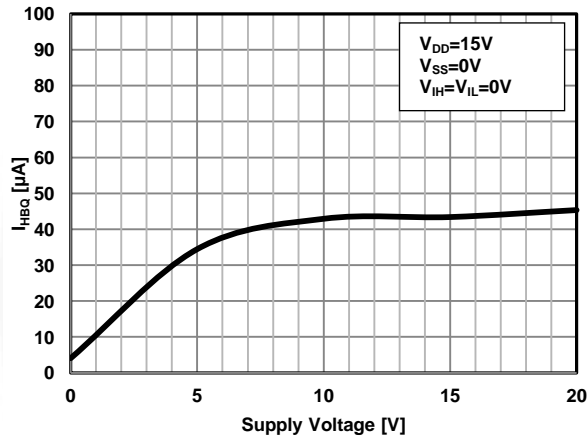

Figure 11. I_{HBQ} vs. Supply Voltage(V_{DD})

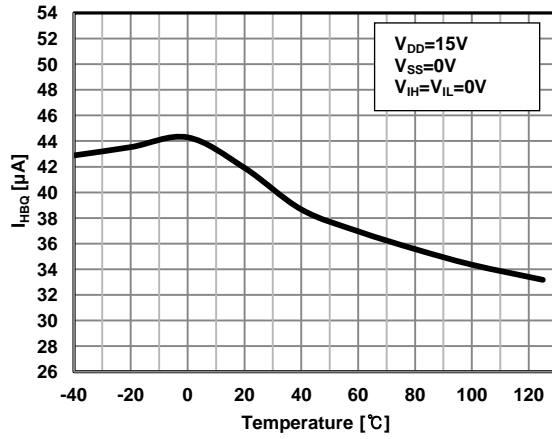

Figure 12. I_{HBQ} vs. Temp.

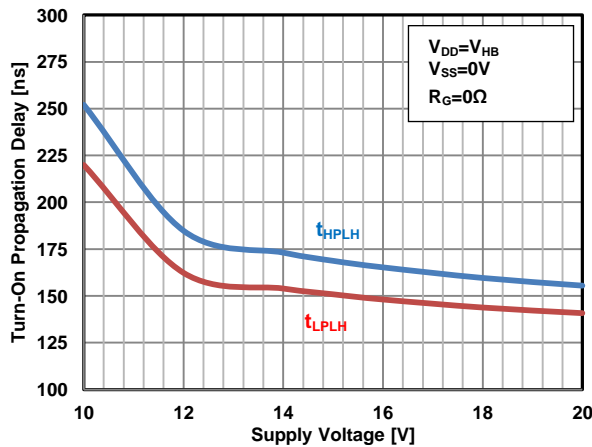

Figure 13. Turn-On Propagation Delay vs. Supply Voltage(V_{DD})

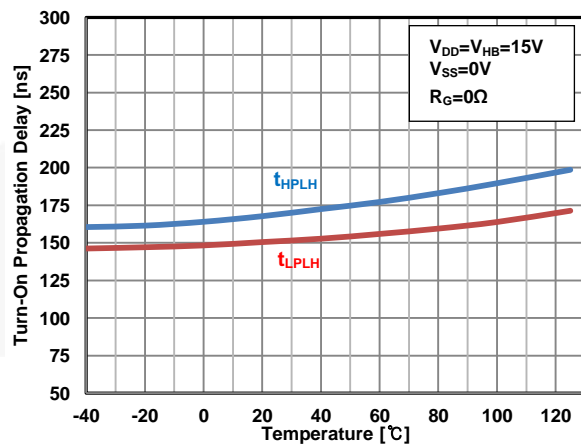

Figure 14. Turn-On Propagation Delay vs. Temp.

Typical Performance Characteristics (Continued)

T_j = 25°C unless otherwise noted.

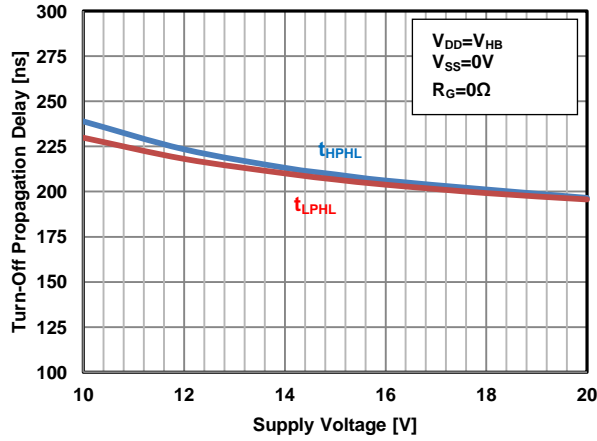

Figure 15. Turn-Off Propagation Delay vs. Supply Voltage (V_{DD})

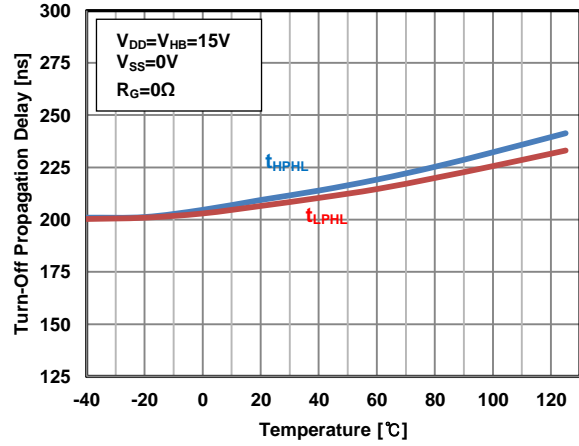

Figure 16. Turn-Off Propagation Delay vs. Temp.

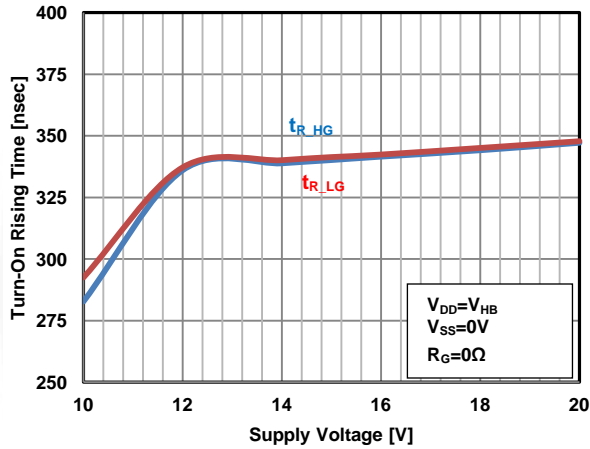

Figure 17. Turn-On Rising Time vs. Supply Voltage (V_{DD})

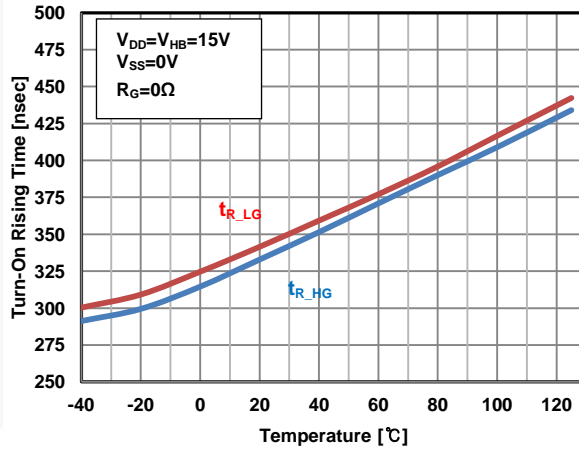

Figure 18. Turn-On Rising Time vs. Temp.

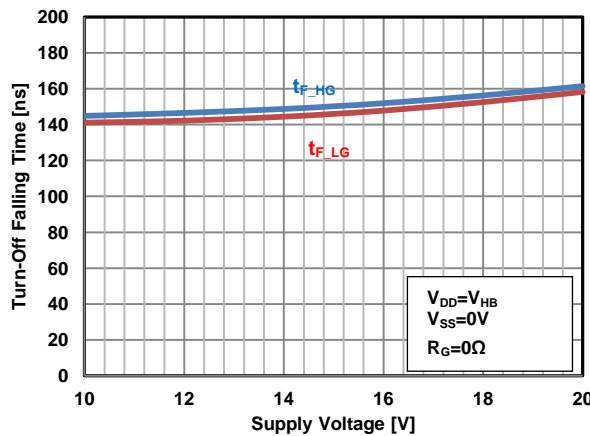

Figure 19. Turn-Off Falling Time vs. Supply Voltage (V_{DD})

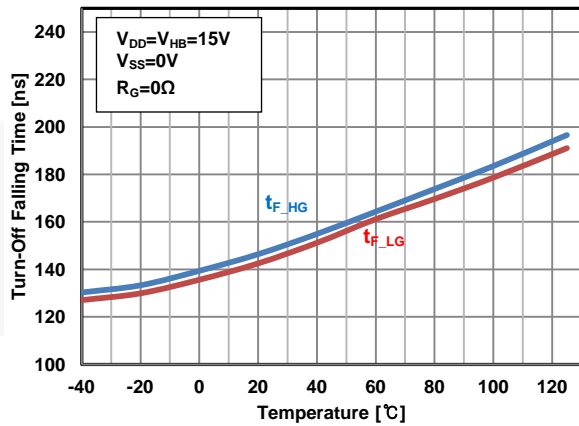

Figure 20. Turn-Off Falling Time vs. Temp.

Typical Performance Characteristics (Continued)

T_j = 25°C unless otherwise noted.

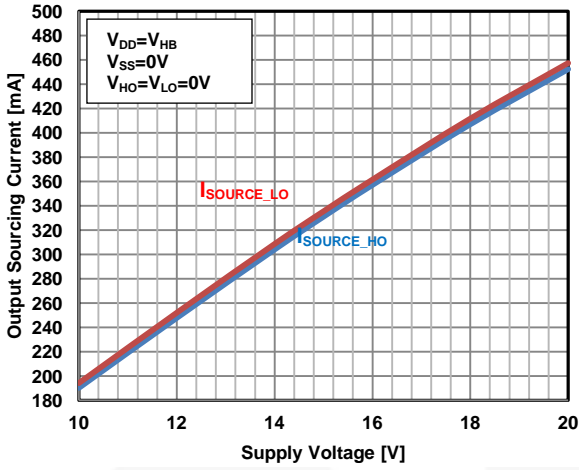

Figure 21. Output Sourcing Current vs. Supply Voltage (V_{DD})

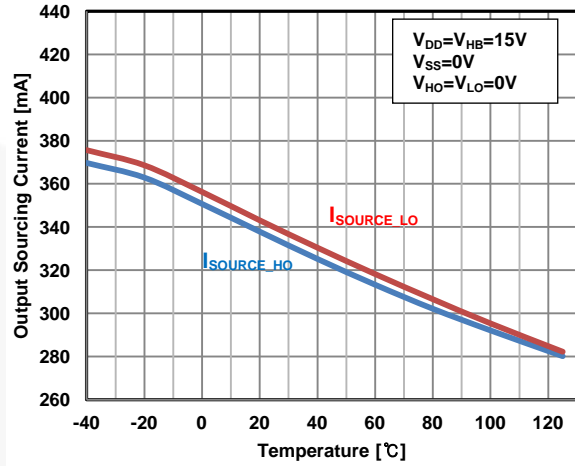

Figure 22. Output Sourcing Current vs. Temp.

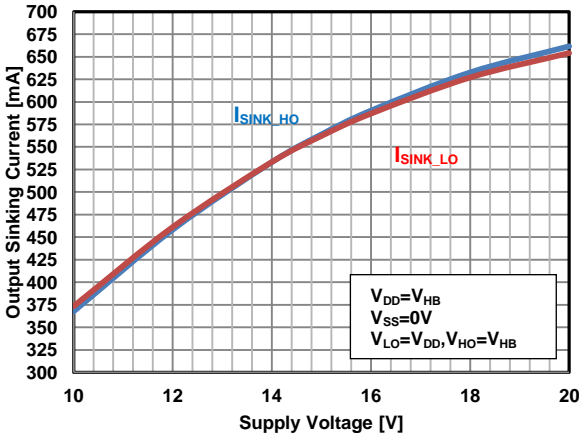

Figure 23. Output Sinking Current vs. Supply Voltage (V_{DD})

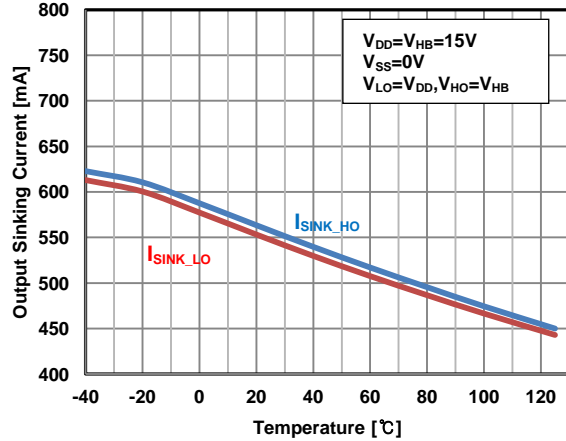

Figure 24. Output Sinking Current vs. Temp.

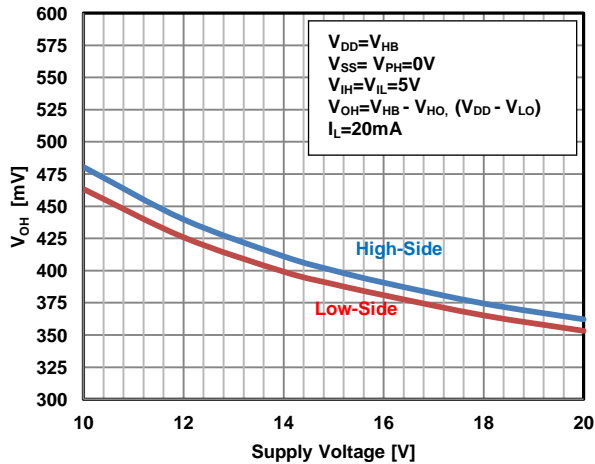

Figure 25. High-Level Output Voltage Deviation from the V_{BH}(V_{DD}) vs. Supply Voltage (V_{DD})

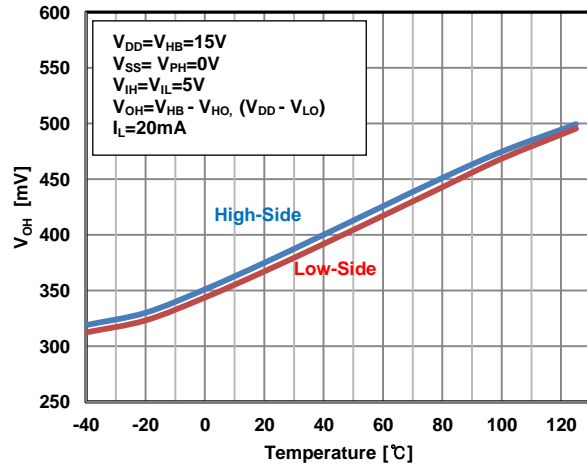

Figure 26. High-Level Output Voltage Deviation from the V_{BH}(V_{DD}) vs. Temp.

Typical Performance Characteristics (Continued)

T_j = 25°C unless otherwise noted.

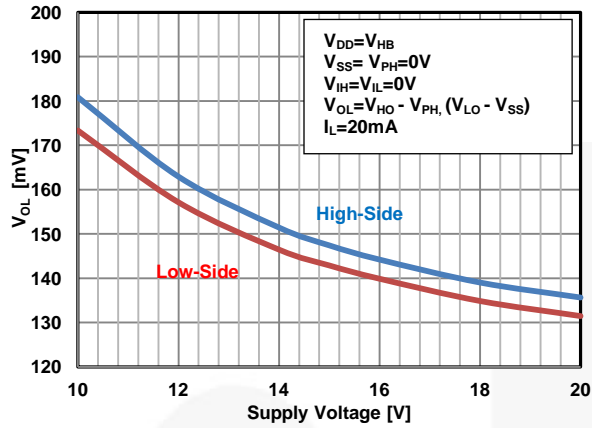

Figure 27. Low-Level Output Voltage Deviation from the V_{PH}(V_{SS}) vs. Supply Voltage(V_{DD})

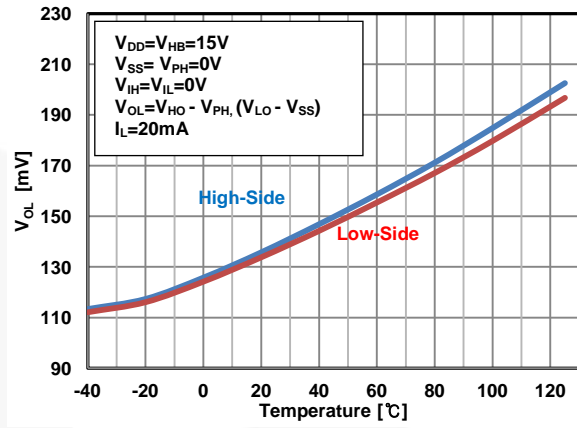

Figure 28. Low-Level Output Voltage Deviation from the V_{PH}(V_{SS}) vs. Temp.

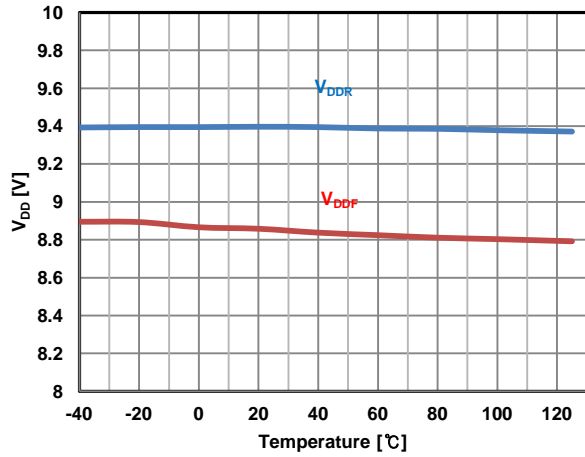

Figure 29. V_{DD} UVLO Threshold Voltage vs. Temp.

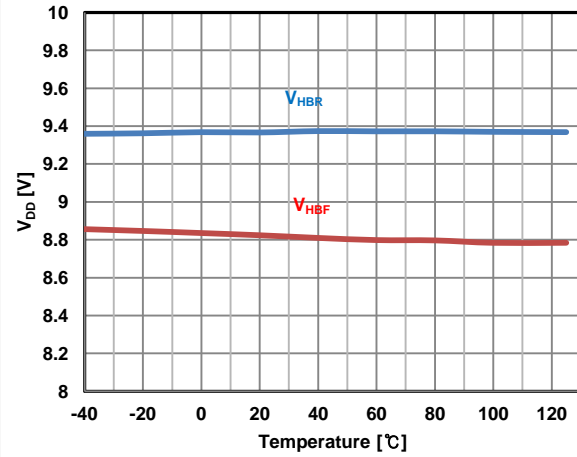

Figure 30. V_{HB} UVLO Threshold Voltage vs. Temp.

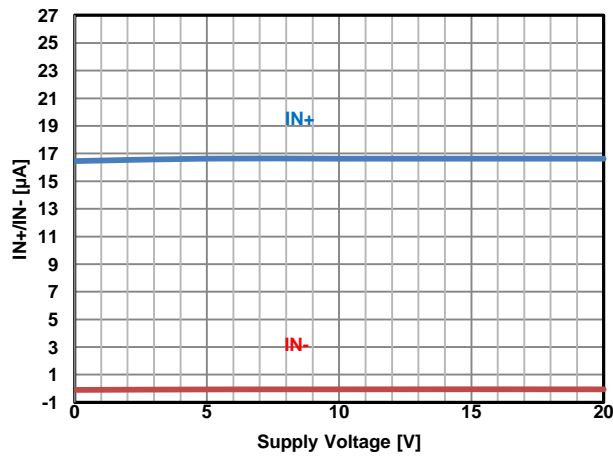

Figure 31. I_{N+} I_{N-} vs. Supply Voltage.

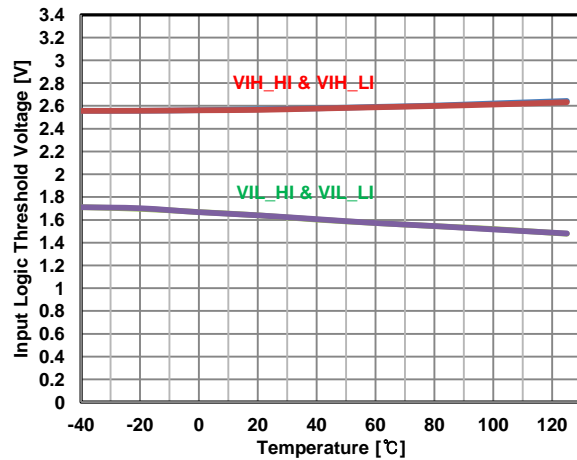

Figure 32. Input Logic Threshold Voltage vs. Temp.

Typical Performance Characteristics (Continued)

$T_j = 25^\circ\text{C}$ unless otherwise noted.

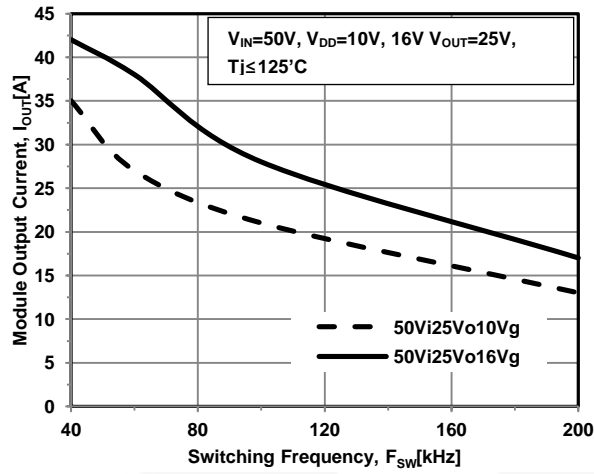

Figure 33. Static SOA, $V_{IN}=50\text{V}$

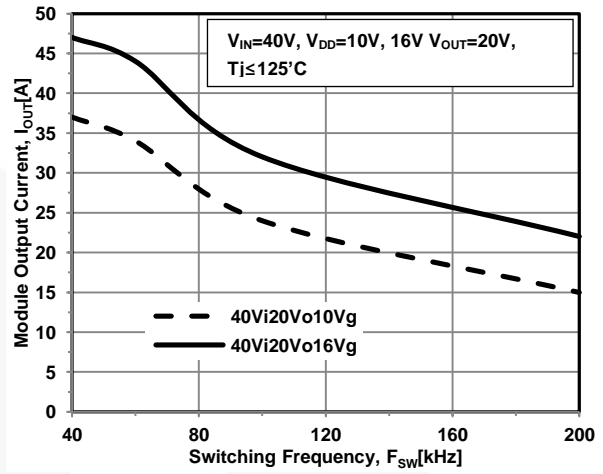

Figure 34. Static SOA, $V_{IN}=40\text{V}$

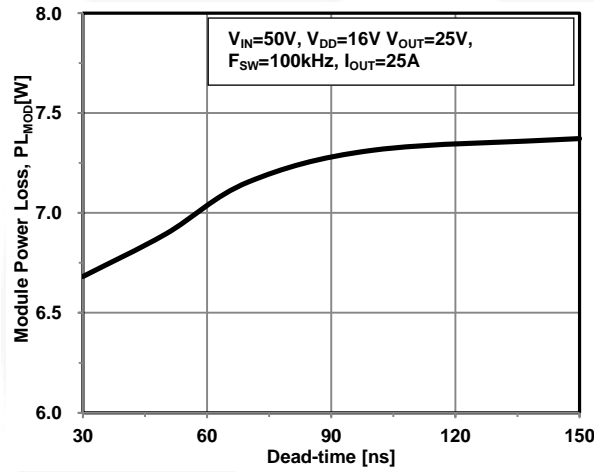

Figure 35. Module Power Loss vs. T_{DEAD}

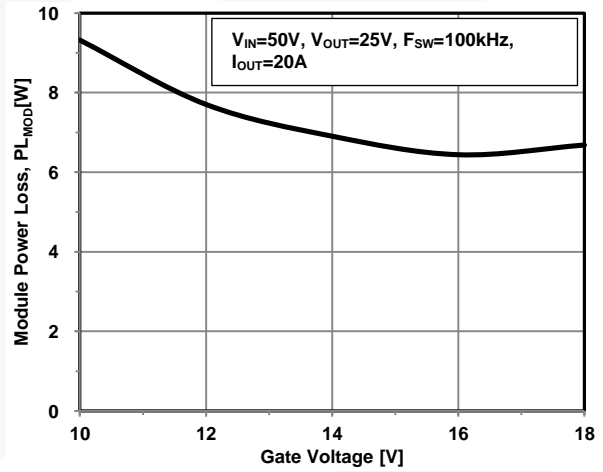

Figure 36. Module Power Loss vs. V_{GS}

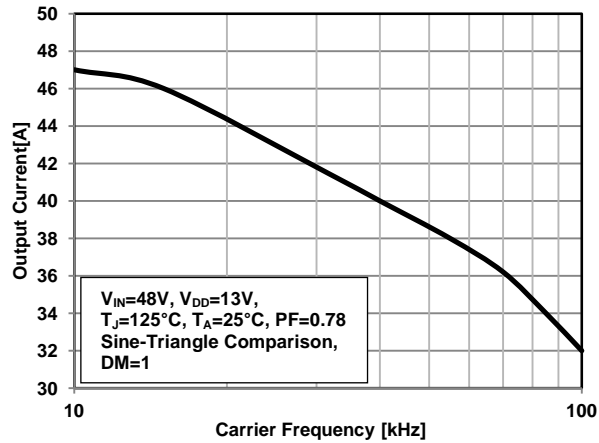

Figure 37. Output Current Vs. Carrier or Modulation Frequency

Typical Performance Characteristics (Q1 N-Channel)

T_j = 25°C unless otherwise noted.

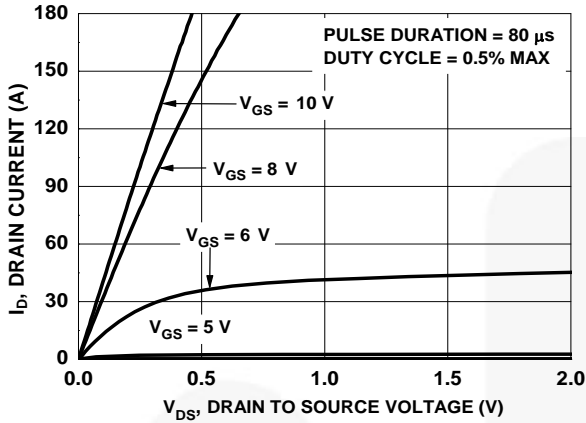

Figure 38. On Region Characteristics

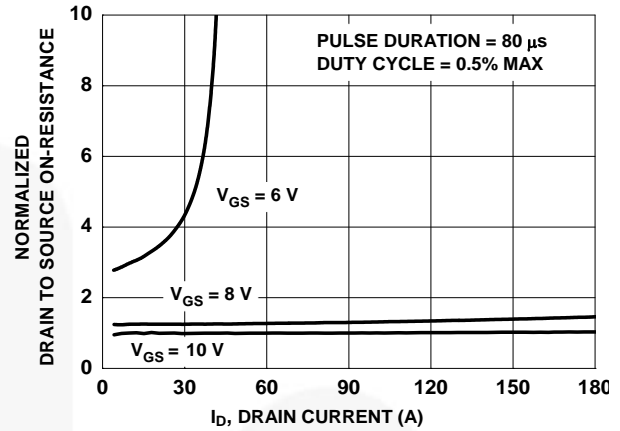

Figure 39. Normalized On-Resistance vs. Drain Current and Gate Voltage

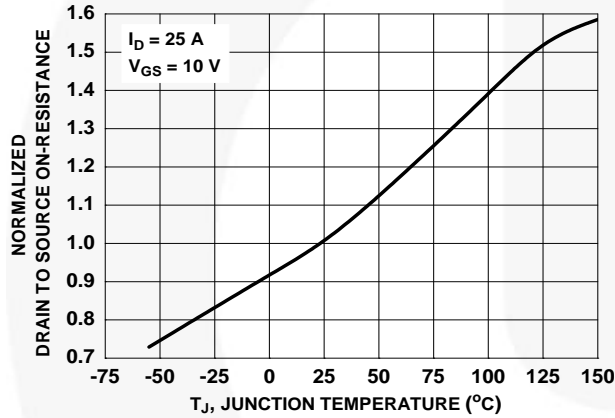

Figure 40. Normalized On Resistance vs. Junction Temperature

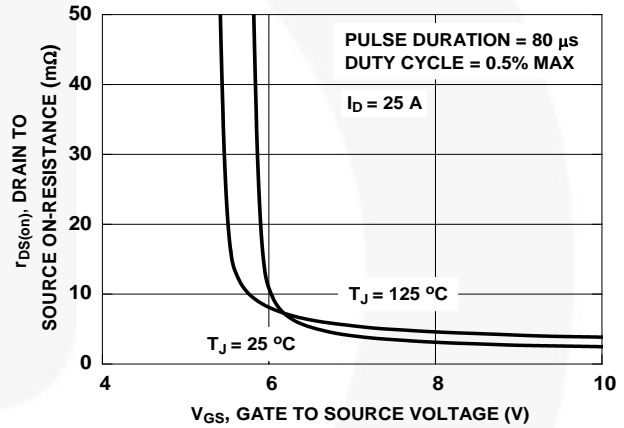

Figure 41. On-Resistance vs. Gate to Source Voltage

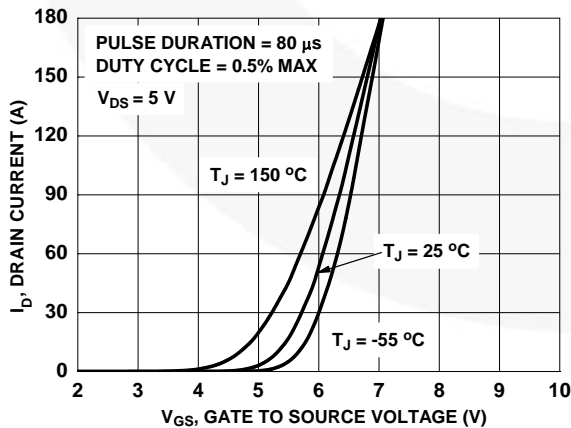

Figure 42. Transfer Characteristics

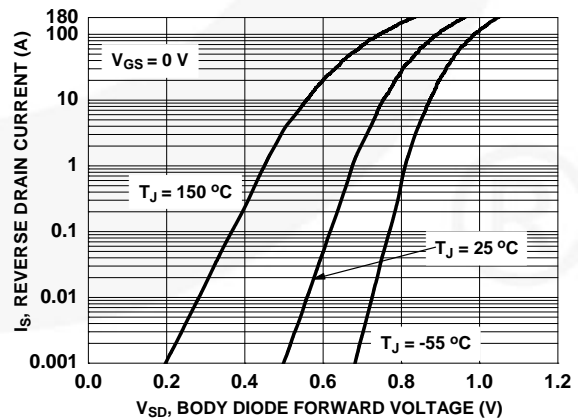

Figure 43. Source to Drain Diode Forward Voltage vs. Source Current

Typical Performance Characteristics (Q1 N-Channel)

$T_j = 25^\circ\text{C}$ unless otherwise noted.

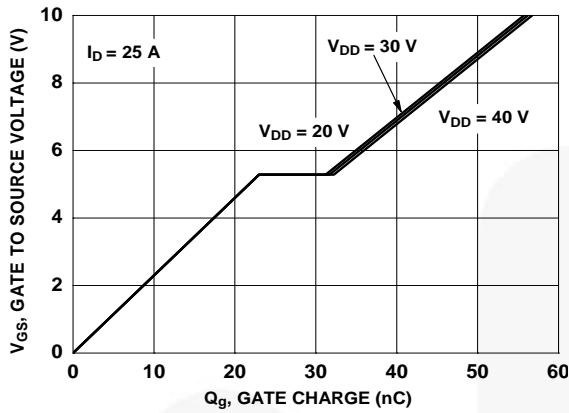

Figure 44. Gate Charge Characteristics

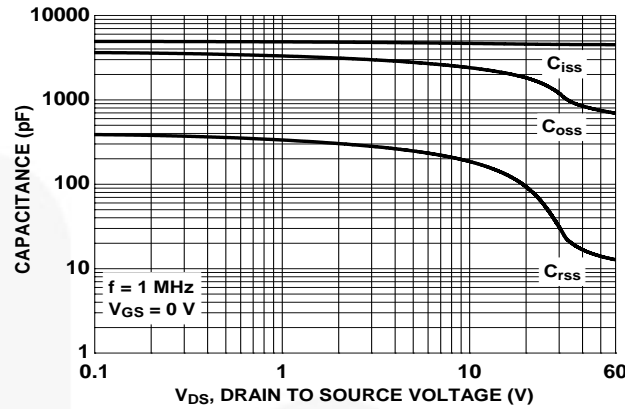

Figure 45. Capacitance vs. Drain to Source Voltage

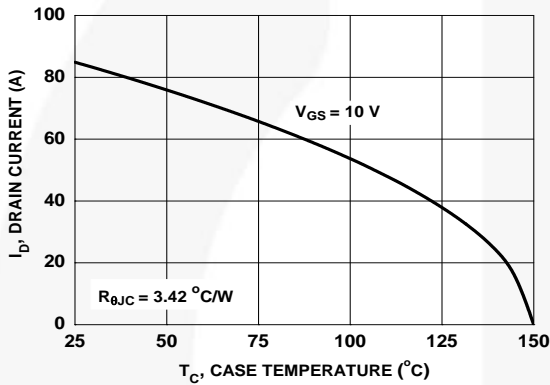

Figure 46. Maximum Continuous Drain Current vs. Case Temperature

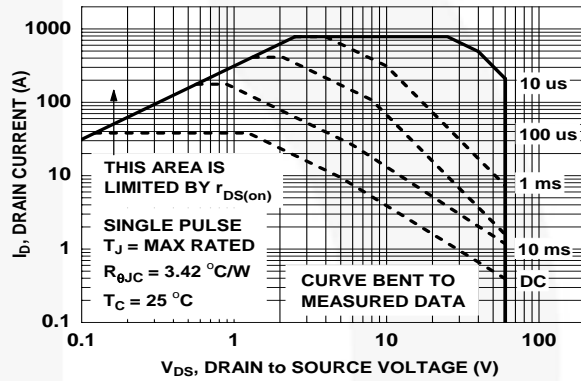

Figure 47. Forward Bias Safe Operating Area

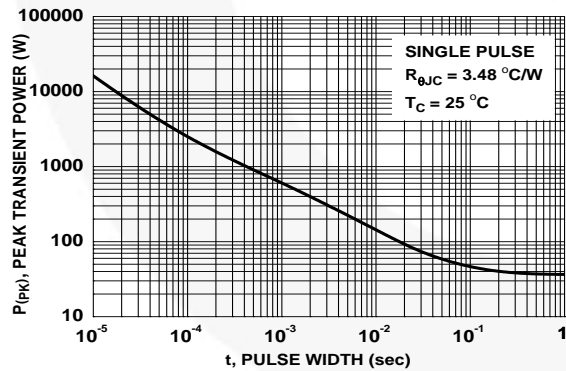

Figure 48. Single Pulse Maximum Power Dissipation

Typical Performance Characteristics (Q1 N-Channel)

T_j = 25°C unless otherwise noted.

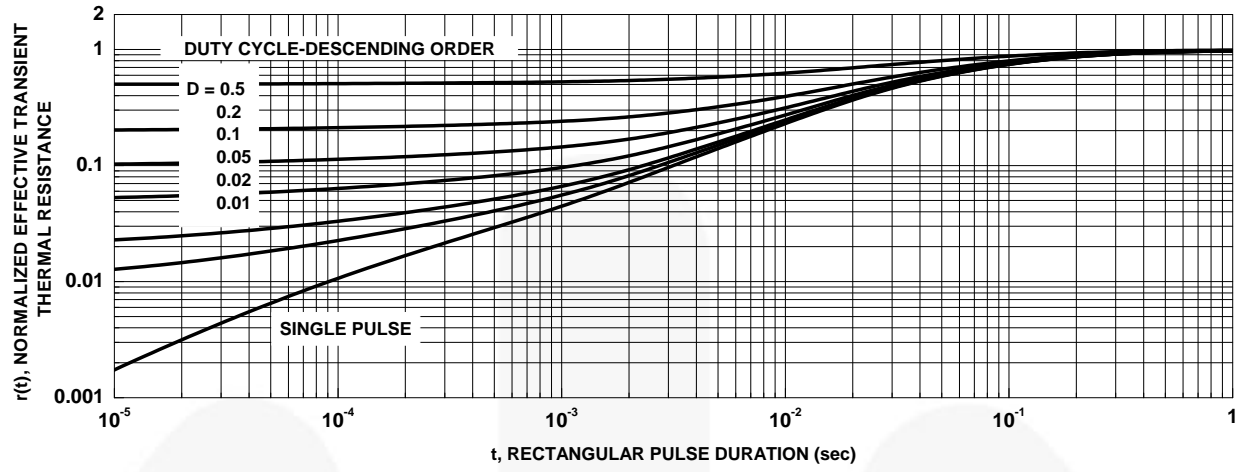

Figure 49. Junction-to-Case Transient Thermal Response Curve

Typical Performance Characteristics (Q2 N-Channel)

T_j = 25°C unless otherwise noted.

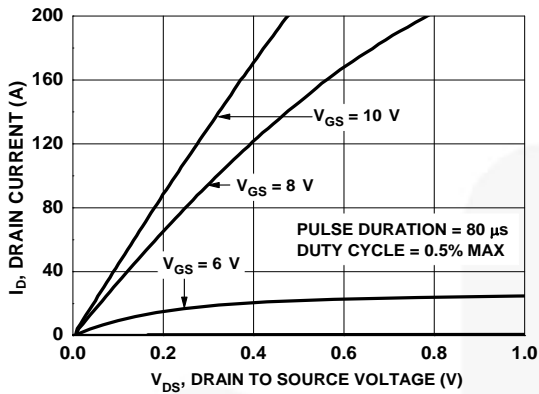

Figure 50. On-Region Characteristics

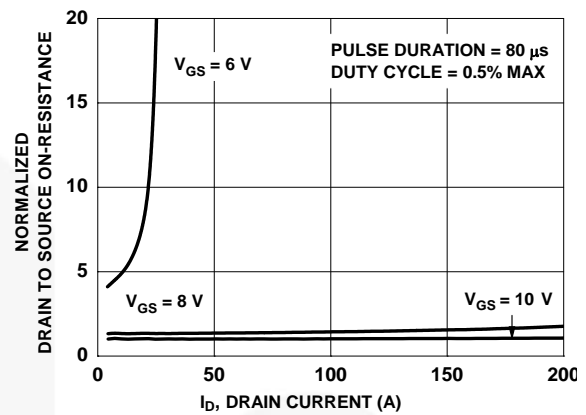

Figure 51. Normalized On-Resistance vs. Drain Current and Gate Voltage

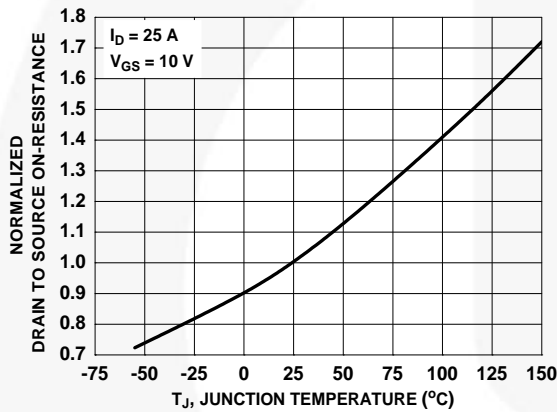

Figure 52. Normalized On Resistance vs. Junction Temperature

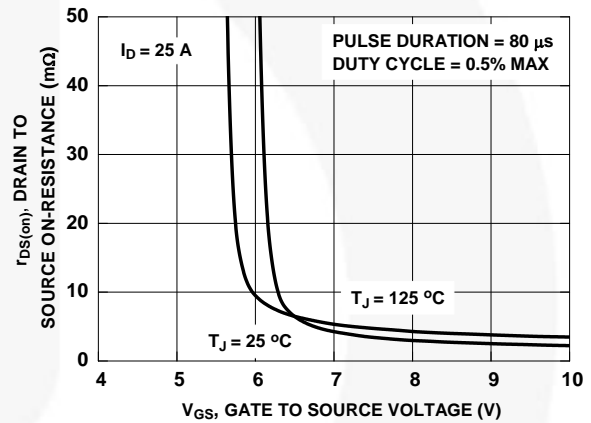

Figure 53. On-Resistance vs. Gate to Source Voltage

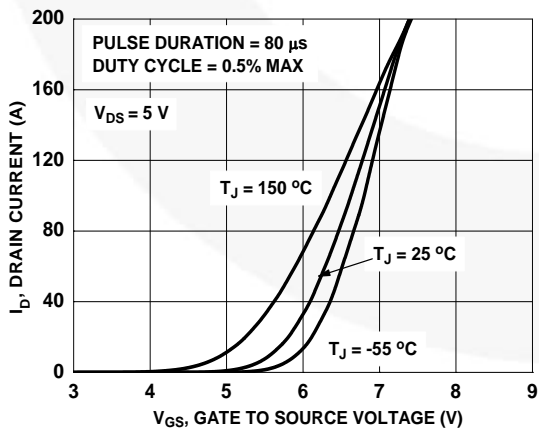

Figure 54. Transfer Characteristics

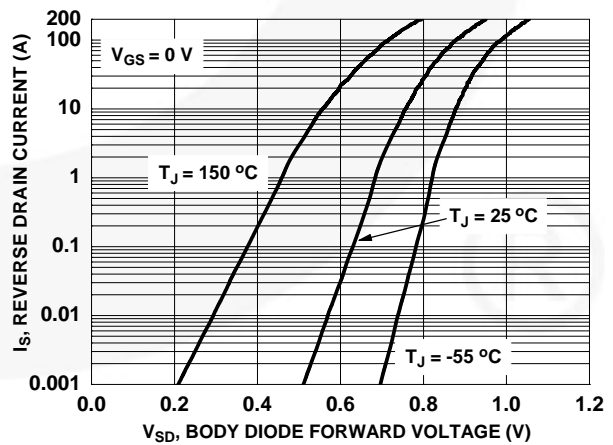

Figure 55. Source to Drain Diode Forward Voltage vs. Source Current

Typical Performance Characteristics (Q2 N-Channel)

$T_j = 25^\circ\text{C}$ unless otherwise noted.

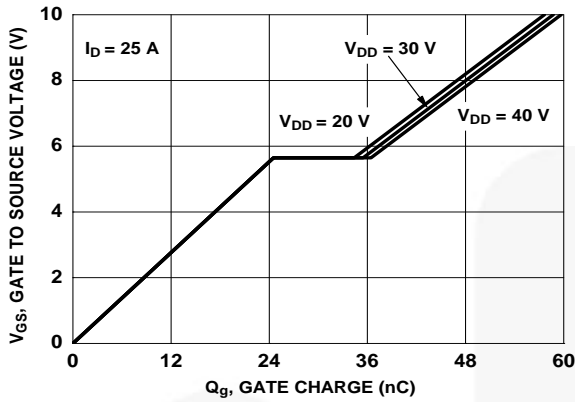

Figure 56. Gate Charge Characteristics

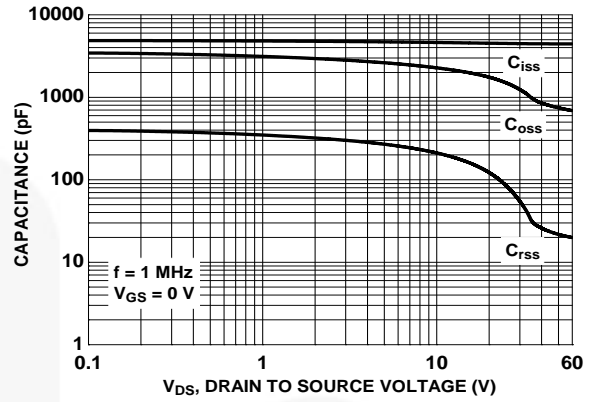

Figure 57. Capacitance vs. Drain to Source Voltage

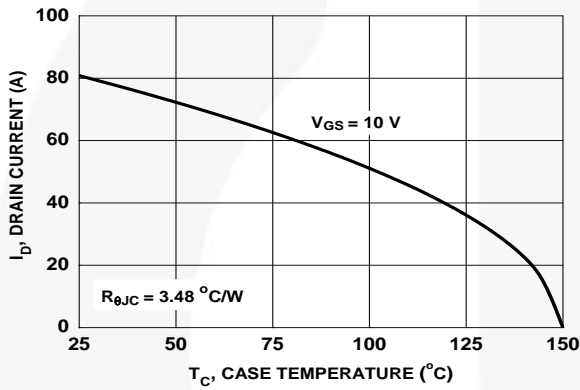

Figure 58. Maximum Continuous Drain Current vs. Case Temperature

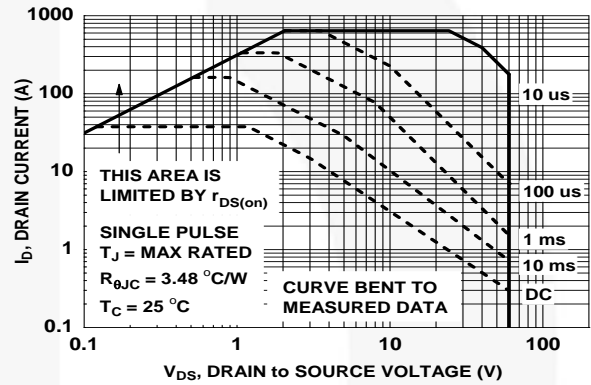

Figure 59. Forward Bias Safe Operating Area

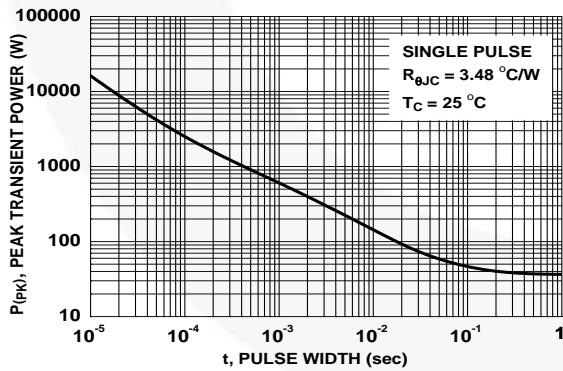

Figure 60. Single Pulse Maximum Power Dissipation

Typical Performance Characteristics (Q2 N-Channel)

$T_j = 25^\circ\text{C}$ unless otherwise noted.

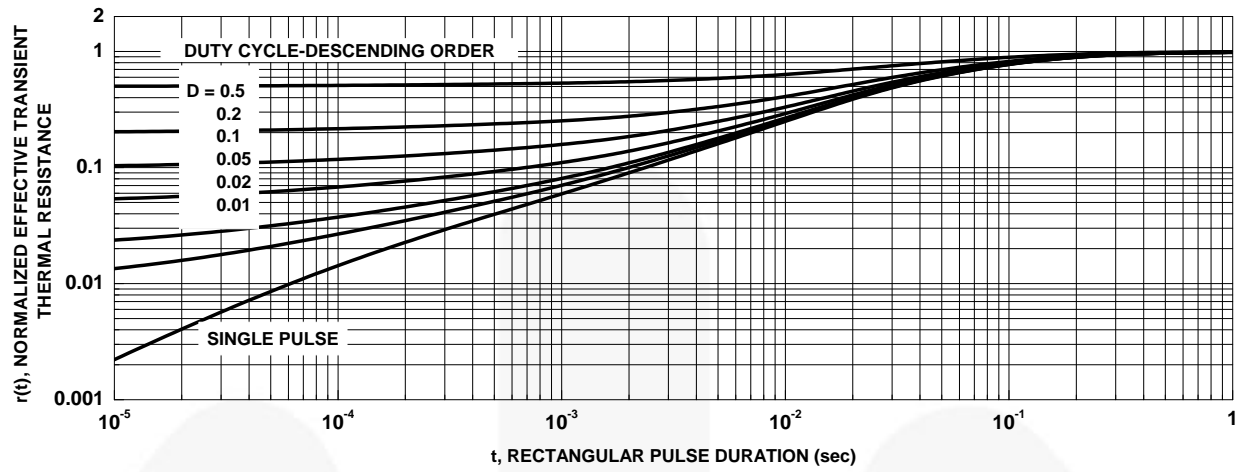

Figure 61. Junction-to-Case Transient Thermal Response Curve

Functional Description

The FDMF4061 is a non-inverting 60V half-bridge Smart Power Stage (SPS) module. The module packages a driver IC die along with pair of equally sized (matched $R_{DS(ON)}$) 60V PowerTrench™ N-Channel MOSFETs (Standard gate thresholds refer to **Table 5**).

The FDMF4061 module provides separate power input pins; the power stage input (VIN) and the gate driver input (VDD). The power stage input (VIN) accepts a wide operating from 3V to 50V, while the gate driver input (VDD) requires 10V to 20V. The module accepts TTL compatible inputs (HI/LI) along with anti-cross conduction circuitry to protect against over-lapping PWM (HI/LI) pulses. The module (driver IC) also implements UVLO circuitry in both the VDD-VSS and BOOT-PH power domains.

Power-Up and UVLO Operation

UVLO circuits are implemented in both the VDD-VSS and HB-PH power domains. During power-up, the VDD-VSS UVLO circuit forces HO and LO low until the VDD supply voltage exceeds the UVLO rising threshold (9.2V typ.). The module (driver IC) will begin responding to PWM pulses once VDD exceeds the UVLO threshold. The UVLO circuit does contain hysteresis (~0.6V) to prevent noise from interfering with normal operation. An additional UVLO circuit is implemented on the HB-PH pins which will hold HO low until HB-PH > (9.2V typ.). The HB-PH UVLO also incorporates hysteresis (~0.6V).

VDD UVLO	BOOT UVLO	Driver State
0	X	Disabled (GH, GL=0)
1	0	GL follows PWM , GH=0)
1	1	Enabled (GH/GL follow PWM)

Table 6. UVLO Truth Table

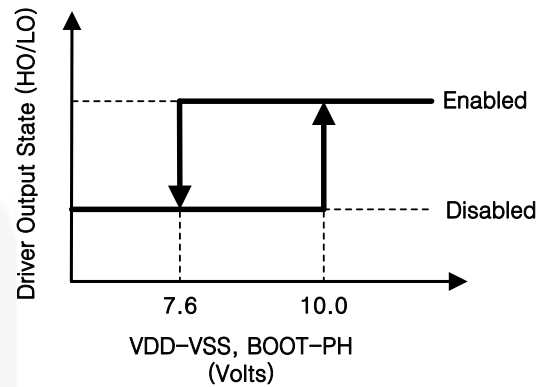

Figure 62. Min/Max UVLO thresholds

PWM Input Stage

The FDMF4061 incorporates a PWM input gate drive design, where the low side drive output (LO) and high side drive output (HO) are controlled through independent PWM inputs (LI and HI, respectively).

The module (driver IC) can be used with TTL compatible input signals. The input signals can also be driven with voltage levels that are lower than the VDD supply level. The VDD supply level does NOT affect the input threshold levels (V_{IH} and V_{IL}).

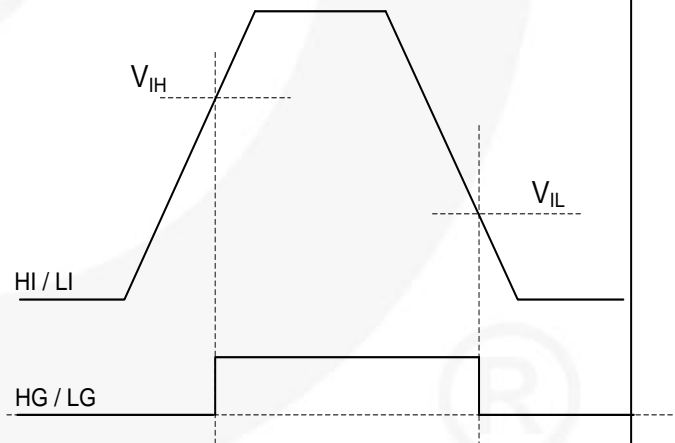

Figure 63. PWM threshold definitions

- V_{IH} = PWM trip level to flip state from LOW to HIGH.
- V_{IL} = PWM trip level to flip state from HIGH to LOW.

Driver Output Stage

The driver IC output stage is designed to drive a pair of N-channel MOSFETs. The driver outputs (LO, HO) are non-inverting and will follow the PWM input commands (LI, HI respectively). The LO and HO outputs are capable of sinking and sourcing up to 0.65/0.35A peak current respectively.

The driver output stage is also capable of providing a rail (VDD) to rail (VSS) output voltage level when driving the Power MOSFETs. Depending on the end application, the output voltage level can be set to aide in optimizing MOSFET and driver IC power losses. The driver output voltage level can also be used to help adjust SW node edge rates.

Timing Diagram

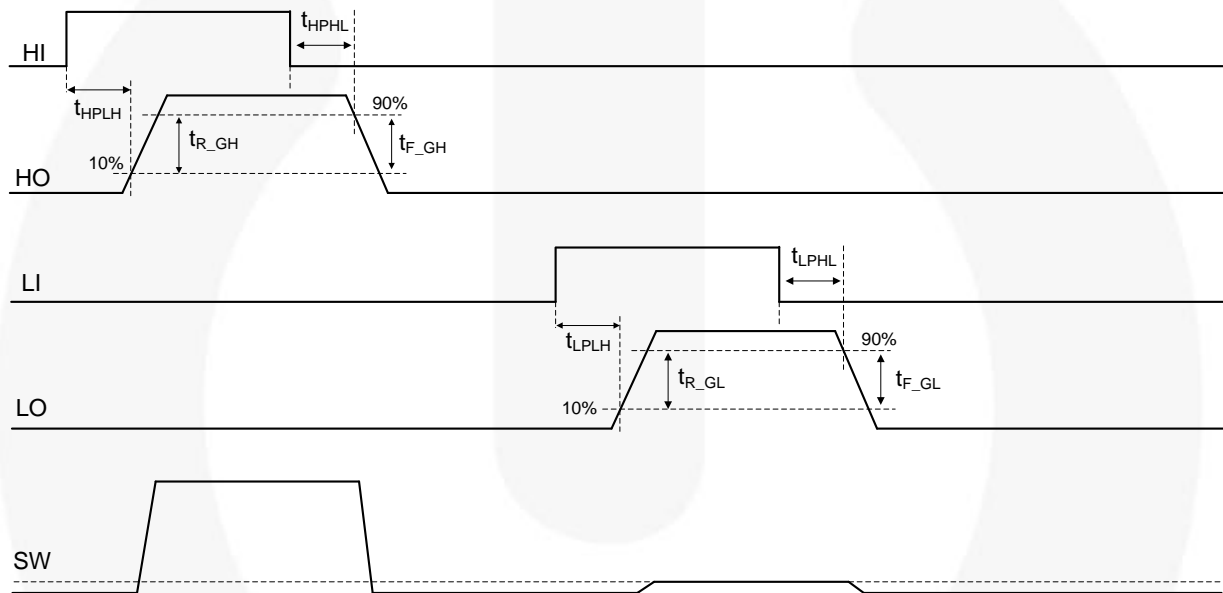

Figure 64. PWM Timing Diagram (LI / HI signals)

Application Information:

The FDMF4061 is designed as a non-inverting power stage, where the Power MOSFET response (SW node) is designed to follow to HI/LI commands. The device is well-suited to be used in a wide variety of applications, such as: Half and Full-Bridge DC-DC converters, Active Clamp Forward converters, rectifier circuits, and motor drive power stages. However, various applications and topologies can place unique stresses on the module. There are a few basic power-stage requirements needed to ensure proper operation.

Module Power Dissipation

As previously mentioned, the FDMF4061 is a multi-chip module (MCM). The module consists of three die (HS MOSFET, LS MOSFET and driver IC). Each die dissipates heat in normal operation resulting from power loss. The power MOSFETs can generate power loss from conduction and switching losses while the driver IC dissipated loss from bias, boot diode conduction and from the driver output stage sinking and sourcing power MOSFET gate currents and operating frequency. The amount of heat dissipated by any die is largely dependent on the operating conditions. The close physical placement of the three die inside of the package translates into strong thermal coupling between die. Ideally, a thermal camera should be used to monitor the FDMF4061 during the engineering development phase. This can help ensure the module operates within the absolute maximum ratings specified in this datasheet.

Operating Modes

The FDMF4061 can reliably operate while driving various load impedances. However, the relatively large number of applications can result in the module operating in various modes. Common applications such as switching power converters and motor drives can place the FDMF4061 into different operating modes. The various operating modes will change the response of the MOSFET voltage and current stresses and power losses as well as the gate driver dead time response. A few operating modes are listed below.

H-bridge Motor Drive

In this operating mode, it allows bi-directional current flow through motor by enabling diagonal MOSFETs to make current flow in one or the other direction. Inductor current will not tolerate abrupt changes either when charged or discharged and alternate path is required to protect switches during dead-time. The path can be made either MOSFET body-diode conducting as soon as switches are disabled or enabling opposite high-side or low-side switch to carry the recirculation current while avoiding shoot-through. Utilizing MOSFET channel is often much more efficient way to handle the decaying current due to lower conduction power loss than body-diode forward drop loss.

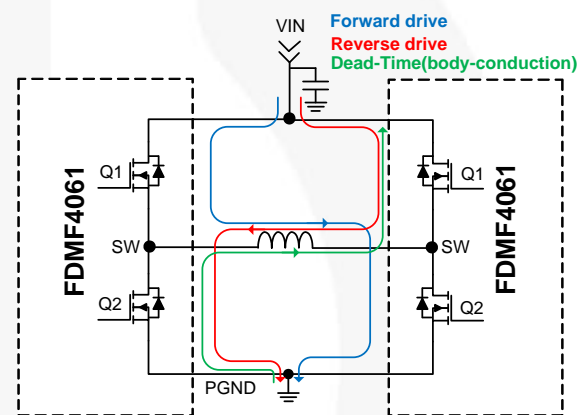

Figure 65. H-bridge motor drive

FDMF4061 Power Dissipation

The maximum motor drive current can be obtained from estimating total power dissipation of motor driver. There are a number of factors which limit actual current level such as motor rating, driver IC, PCB construction, ambient temperature and given application. All of power dissipation components must be considered to get reliable operation at the specific application. There is obvious power dissipations listed below in single H-bridge motor application.

- Conduction loss – Generally biggest power loss which is dissipated due to the $R_{DS(ON)}$ and its temperature coefficient must be considered in the calculation

$$P_{COND} = (r_{DS(ON)-HS_temp} + r_{DS(ON)-LS_temp}) \cdot I_{OUT}^2$$

- Switching losses - Rising and falling time by parasitic inductance can be measured in the application, listed below assumed zero inductance.

Switching OFF loss

$$P_{SW(OFF)} = \left(\frac{V_{IN} \cdot I_{DS(OFF)} \cdot t_{OFF}}{2} \right) \cdot F_{SW}$$

where:

$$t_{OFF} = (Q_{GS2} + Q_{GD}) / i_{G(OFF)}$$

$$i_{G(OFF)} = V_{PLATEAU} / (R_{GH} + R_{DRV_OFF})$$

Switching ON loss

$$P_{SW(ON)} = \left(\frac{V_{IN} \cdot I_{DS(ON)} \cdot t_{ON}}{2} + \frac{Q_{OSS} \cdot V_{IN}}{2} \right) \cdot F_{SW}$$

where:

$$t_{ON} = (Q_{GS2} + Q_{GD}) / i_{G(ON)}$$

$$i_{G(ON)} = V_{PLATEAU} / (R_G + R_{DRV_ON})$$

Q_{OSS} = Output Charge

- Gate drive loss

$$P_{GATE} = Q_G \cdot V_{DRV} \cdot F_{SW}$$

- Quiescent current power loss – Current is still drawn from the VDD and HB pins for internal and level shifting circuitry without load (R_G=Open). Power loss by quiescent current is

$$P_{Quiescent} = V_{DD} \cdot I_{DDQ} + V_{HB} \cdot I_{HBQ}$$

- Supply current power loss (R_G=0Ω) is

$$P_{supply} = V_{DD} \cdot I_{DDO} + V_{HB} \cdot I_{HBO}$$

- Total power loss in the FDMF4061 is equal to the power dissipation caused by gate driver and Power MOSFETs,

$$P_{total} = P_{Cond} + P_{SW} + P_{Gate} + P_{supply}$$

Once the designer estimates power dissipation in the gate driver and MOSFETs, junction temperature can be calculated using thermal resistance (Θ_{JA}) and ambient temperature as followings and also can calculate maximum allowable motor current:

$$T_j = T_A + (\Theta_{JA} \cdot P_{total})$$

Continuous current flowing out of SW node.

Continuous current flowing out of the module SW node is typical of a heavily loaded switched-mode power stage that is operating in a synchronous buck converter topology. In this mode, the power stage is supplying current from VIN into an inductive load. **Figure 66** shows an example of a synchronous buck converter operating in CCM with positive inductor current.

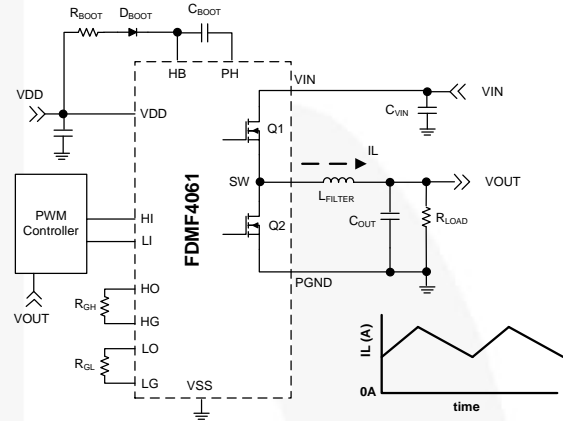

Figure 66. Synchronous Buck Operating in CCM with positive inductor current

During this operating mode, the HS MOSFET (Q1) will undergo hard-switched inductive turn-on and turn-off events, while LS MOSFET (Q2) will undergo soft switching and body diode recovery. Hard-switching often results in large switching spikes on Q1 and Q2 V_{DS} as well as PH to VSS and BOOT to VSS pins. Peak switching spikes are often positively correlated to load current.

Continuous current flowing into SW node.

Continuous current flowing into the module SW node is typical of a heavily loaded switched-mode power stage that is operating in a synchronous boost converter topology.

Continuous inductor current flowing in to the module SW node is typical operation of a synchronous boost converter, as shown in **Figure 67**.

However, similar operation can arise when a switching converter (such as a synchronous buck) is pulling energy from the output filter capacitors and delivering the energy back to the input filter capacitors.

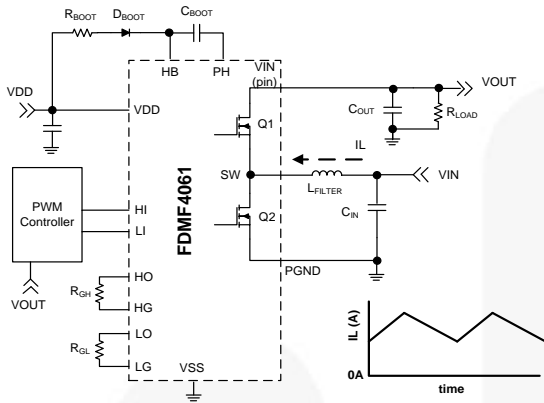

Figure 67. Synchronous Boost Converter operating in CCM

From a module perspective, the main difference here versus the previous (buck) operating mode is that this situation will cause the LS FET (Q2) to act as the control MOSFET and hard switch while the HS FET (Q1) acts as a synchronous rectifier and undergoes soft switching with body diode recovery. This type of operation can drastically change power losses dissipated in Q1 and Q2 versus buck operating mode.

dV_{DS}/dt control using external gate resistors

The FDMF4061 also provides module pins for placing external gate resistors. The module provides pins for the HO and LO signals (driver output signals) and the HG and LG (Power MOSFET gate pins). Resistors can be placed in series with the MOSFET gate to control the SW node edge rates.

Independently controlling MOSFET (slower) turn-on and (faster) turn-off slew rates can also be accomplished by using the resistor and diode circuit shown in **Figure 68**.

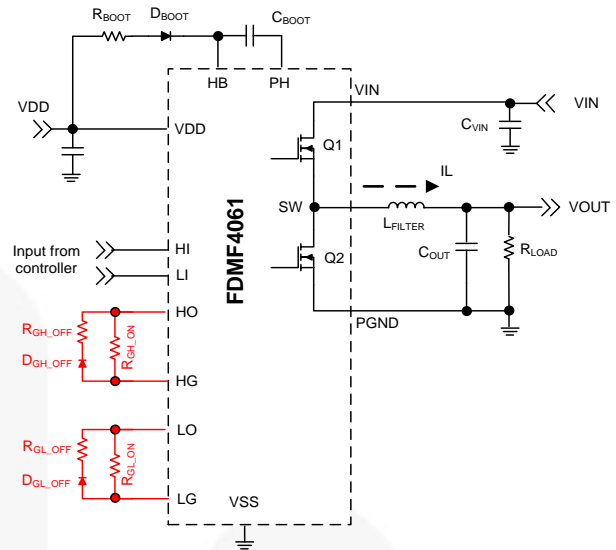

Figure 68. Gate drive resistor-diode circuit

C_{GD} x dV_{DS}/dt turn-on

C_{GD} x dV_{DS}/dt turn-on is a false (unwanted) turn-on event that often creates a brief and uncontrolled shoot through current between the HS (Q1) and LS (Q2) MOSFETs.

Typically, a C_{GD} x dV_{DS}/dt “shoot-through” condition arises from capacitive feedback current flowing through C_{GD} into C_{GS} inducing a gate-bounce-induced channel turn-on of the MOSFET. Holding the gate below threshold can become challenging because the high-frequency capacitive displacement current from C_{GD} (due to dV_{DS}/dt) couples back to circuit ground through the gate electrode.

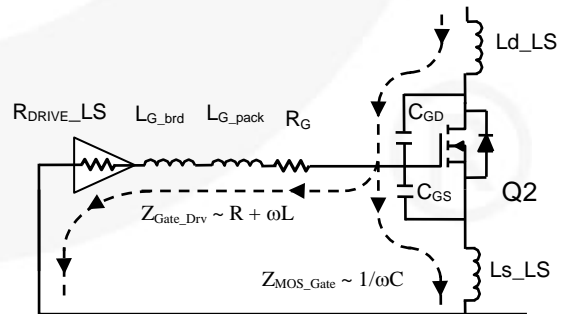

Figure 69. C_{GD} x dV_{DS}/dt current flow

The gate-to-ground impedance is the parallel combination of the gate drive (Z_{G_DRV}) and the MOSFET gate-to-source (Z_{MOS_Gate}) paths. As dV_{DS}/dt increases, the more favorable path for displacement current is through the capacitive gate-source (C_{GS}) path versus the highly inductive and resistive gate drive loop. So impedance through gate driver should be minimized. The severity of the shoot through current is difficult to predict.



Physical Dimensions

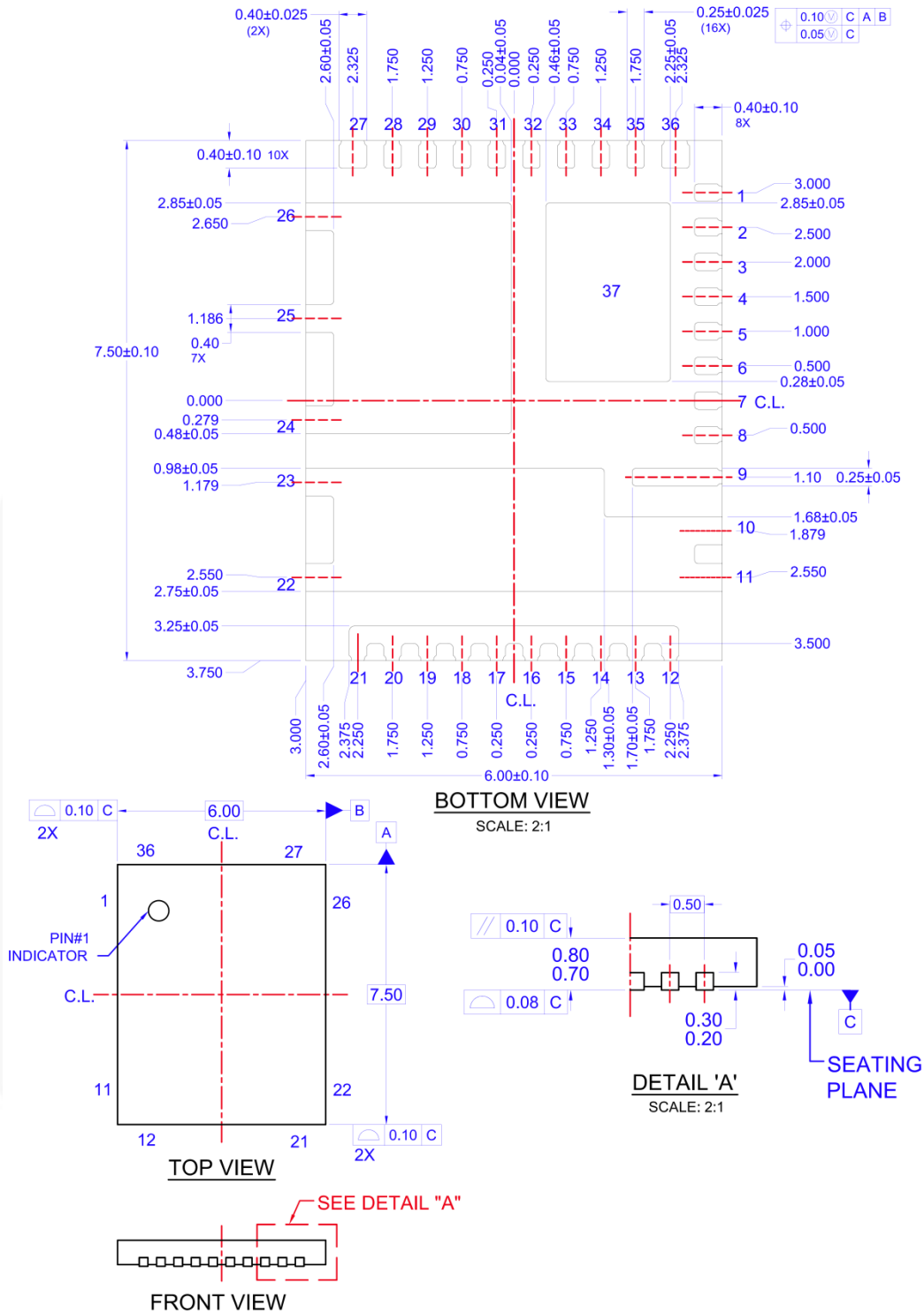
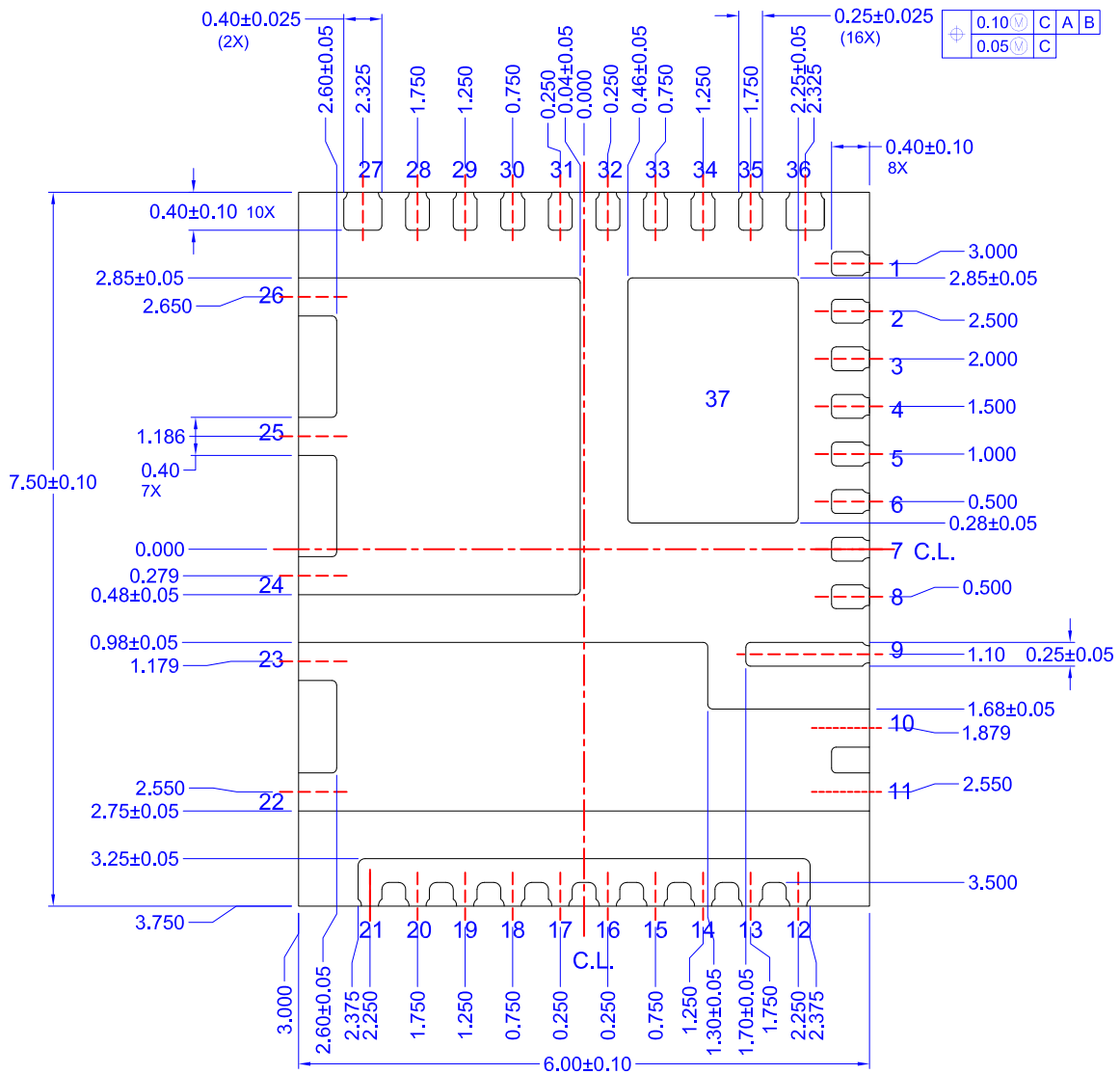

Figure 70. Clip Bond PQFN 6.0mm x 7.5mm Package Dimensions

Package drawings are provided as a service to customers considering Fairchild components. Drawings may change in any manner without notice. Please note the revision and/or date on the drawing and contact a Fairchild Semiconductor representative to verify or obtain the most recent revision. Package specifications do not expand the terms of Fairchild's worldwide terms and conditions, specifically the warranty therein, which covers Fairchild products.

Always visit Fairchild Semiconductor's online packaging area for the most recent package drawings:

<http://www.fairchildsemi.com/packaging/>.



BOTTOM VIEW

SCALE: 2:1

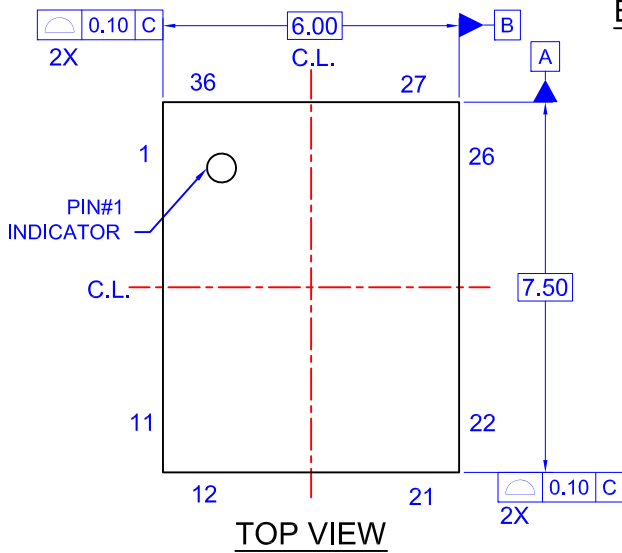

TOP VIEW

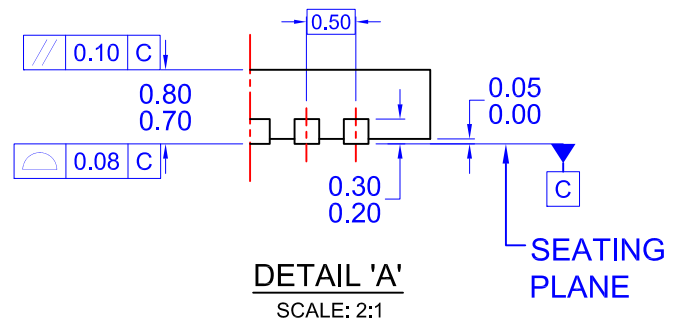

DETAIL 'A'

SCALE: 2:1

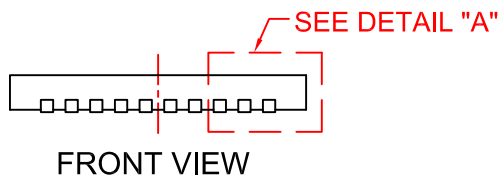

FRONT VIEW



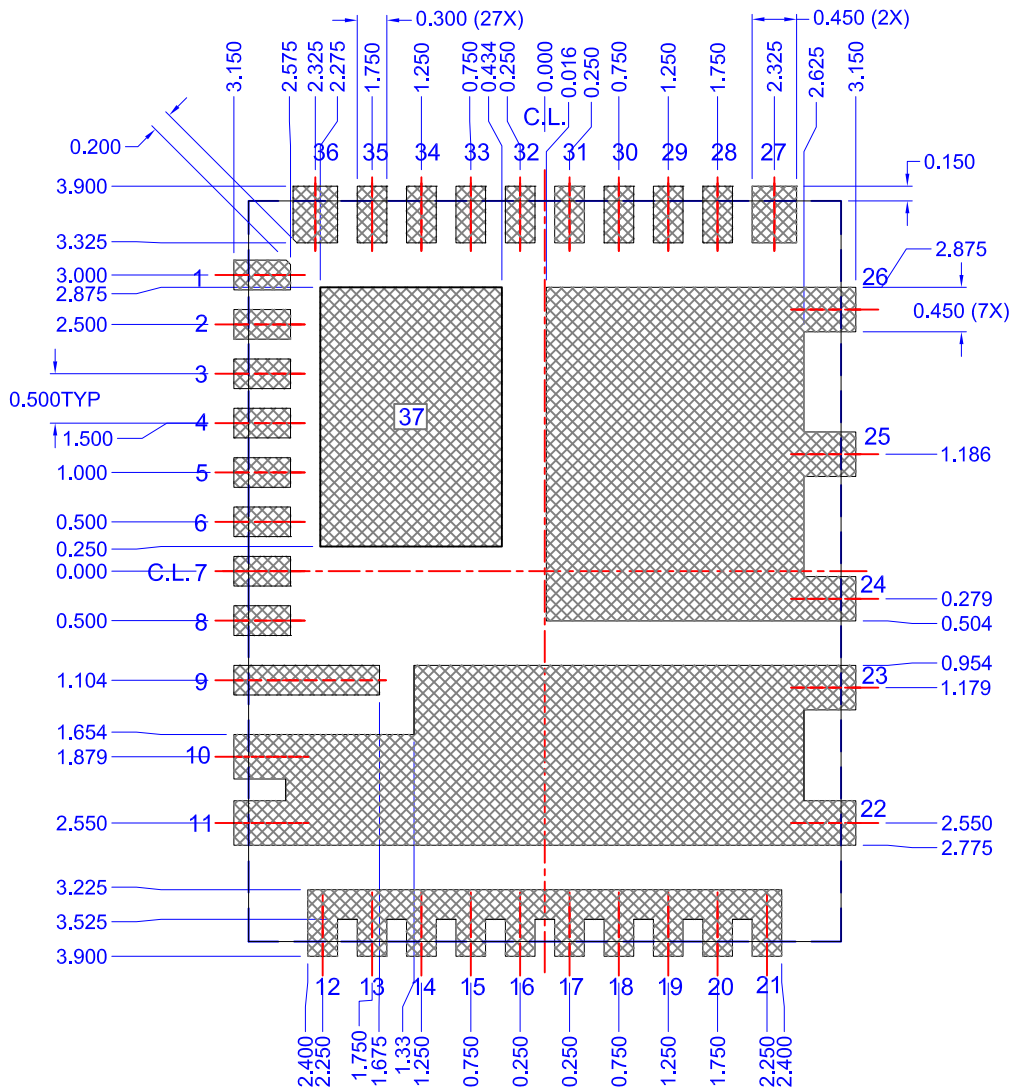

LAND PATTERN RECOMMENDATION

SCALE 2:1

NOTES: UNLESS OTHERWISE SPECIFIED

- A) DOES NOT FULLY CONFORM TO JEDEC MO-220, ISSUE K.01, DATED AUG 2011.
- B) ALL DIMENSIONS ARE IN MILLIMETERS.
- C) DIMENSIONS DO NOT INCLUDE BURRS OR MOLD FLASH. MOLD FLASH OR BURRS DOES NOT EXCEED 0.10MM.
- D) DIMENSIONING AND TOLERANCING PER ASME Y14.5M-2009.
- E) DRAWING FILE NAME: MKT-PQFN36BREV3



ON Semiconductor and  are trademarks of Semiconductor Components Industries, LLC dba ON Semiconductor or its subsidiaries in the United States and/or other countries. ON Semiconductor owns the rights to a number of patents, trademarks, copyrights, trade secrets, and other intellectual property. A listing of ON Semiconductor's product/patent coverage may be accessed at www.onsemi.com/site/pdf/Patent-Marking.pdf. ON Semiconductor reserves the right to make changes without further notice to any products herein. ON Semiconductor makes no warranty, representation or guarantee regarding the suitability of its products for any particular purpose, nor does ON Semiconductor assume any liability arising out of the application or use of any product or circuit, and specifically disclaims any and all liability, including without limitation special, consequential or incidental damages. Buyer is responsible for its products and applications using ON Semiconductor products, including compliance with all laws, regulations and safety requirements or standards, regardless of any support or applications information provided by ON Semiconductor. "Typical" parameters which may be provided in ON Semiconductor data sheets and/or specifications can and do vary in different applications and actual performance may vary over time. All operating parameters, including "Typicals" must be validated for each customer application by customer's technical experts. ON Semiconductor does not convey any license under its patent rights nor the rights of others. ON Semiconductor products are not designed, intended, or authorized for use as a critical component in life support systems or any FDA Class 3 medical devices or medical devices with a same or similar classification in a foreign jurisdiction or any devices intended for implantation in the human body. Should Buyer purchase or use ON Semiconductor products for any such unintended or unauthorized application, Buyer shall indemnify and hold ON Semiconductor and its officers, employees, subsidiaries, affiliates, and distributors harmless against all claims, costs, damages, and expenses, and reasonable attorney fees arising out of, directly or indirectly, any claim of personal injury or death associated with such unintended or unauthorized use, even if such claim alleges that ON Semiconductor was negligent regarding the design or manufacture of the part. ON Semiconductor is an Equal Opportunity/Affirmative Action Employer. This literature is subject to all applicable copyright laws and is not for resale in any manner.

PUBLICATION ORDERING INFORMATION

LITERATURE FULFILLMENT:

Literature Distribution Center for ON Semiconductor
19521 E. 32nd Pkwy, Aurora, Colorado 80011 USA
Phone: 303-675-2175 or 800-344-3860 Toll Free USA/Canada
Fax: 303-675-2176 or 800-344-3867 Toll Free USA/Canada
Email: orderlit@onsemi.com

N. American Technical Support: 800-282-9855 Toll Free
USA/Canada
Europe, Middle East and Africa Technical Support:
Phone: 421 33 790 2910
Japan Customer Focus Center
Phone: 81-3-5817-1050

ON Semiconductor Website: www.onsemi.com
Order Literature: <http://www.onsemi.com/orderlit>
For additional information, please contact your local
Sales Representative

Mouser Electronics

Authorized Distributor

Click to View Pricing, Inventory, Delivery & Lifecycle Information:

[ON Semiconductor:](#)

[FDMF4061](#)

Компания «Океан Электроники» предлагает заключение долгосрочных отношений при поставках импортных электронных компонентов на взаимовыгодных условиях!

Наши преимущества:

- Поставка оригинальных импортных электронных компонентов напрямую с производств Америки, Европы и Азии, а так же с крупнейших складов мира;
- Широкая линейка поставок активных и пассивных импортных электронных компонентов (более 30 млн. наименований);
- Поставка сложных, дефицитных, либо снятых с производства позиций;
- Оперативные сроки поставки под заказ (от 5 рабочих дней);
- Экспресс доставка в любую точку России;
- Помощь Конструкторского Отдела и консультации квалифицированных инженеров;
- Техническая поддержка проекта, помощь в подборе аналогов, поставка прототипов;
- Поставка электронных компонентов под контролем ВП;
- Система менеджмента качества сертифицирована по Международному стандарту ISO 9001;
- При необходимости вся продукция военного и аэрокосмического назначения проходит испытания и сертификацию в лаборатории (по согласованию с заказчиком);
- Поставка специализированных компонентов военного и аэрокосмического уровня качества (Xilinx, Altera, Analog Devices, Intersil, Interpoint, Microsemi, Actel, Aeroflex, Peregrine, VPT, Syfer, Eurofarad, Texas Instruments, MS Kennedy, Miteq, Cobham, E2V, MA-COM, Hittite, Mini-Circuits, General Dynamics и др.);

Компания «Океан Электроники» является официальным дистрибьютором и эксклюзивным представителем в России одного из крупнейших производителей разъемов военного и аэрокосмического назначения «**JONHON**», а так же официальным дистрибьютором и эксклюзивным представителем в России производителя высокотехнологичных и надежных решений для передачи СВЧ сигналов «**FORSTAR**».



JONHON

«**JONHON**» (основан в 1970 г.)

Разъемы специального, военного и аэрокосмического назначения:

(Применяются в военной, авиационной, аэрокосмической, морской, железнодорожной, горно- и нефтедобывающей отраслях промышленности)

«**FORSTAR**» (основан в 1998 г.)

ВЧ соединители, коаксиальные кабели,
кабельные сборки и микроволновые компоненты:

(Применяются в телекоммуникациях гражданского и специального назначения, в средствах связи, РЛС, а так же военной, авиационной и аэрокосмической отраслях промышленности).



Телефон: 8 (812) 309-75-97 (многоканальный)

Факс: 8 (812) 320-03-32

Электронная почта: ocean@oceanchips.ru

Web: <http://oceanchips.ru/>

Адрес: 198099, г. Санкт-Петербург, ул. Калинина, д. 2, корп. 4, лит. А