

# M SERIES CONNECTORS RATCHET COUPLING

**M** SERIES

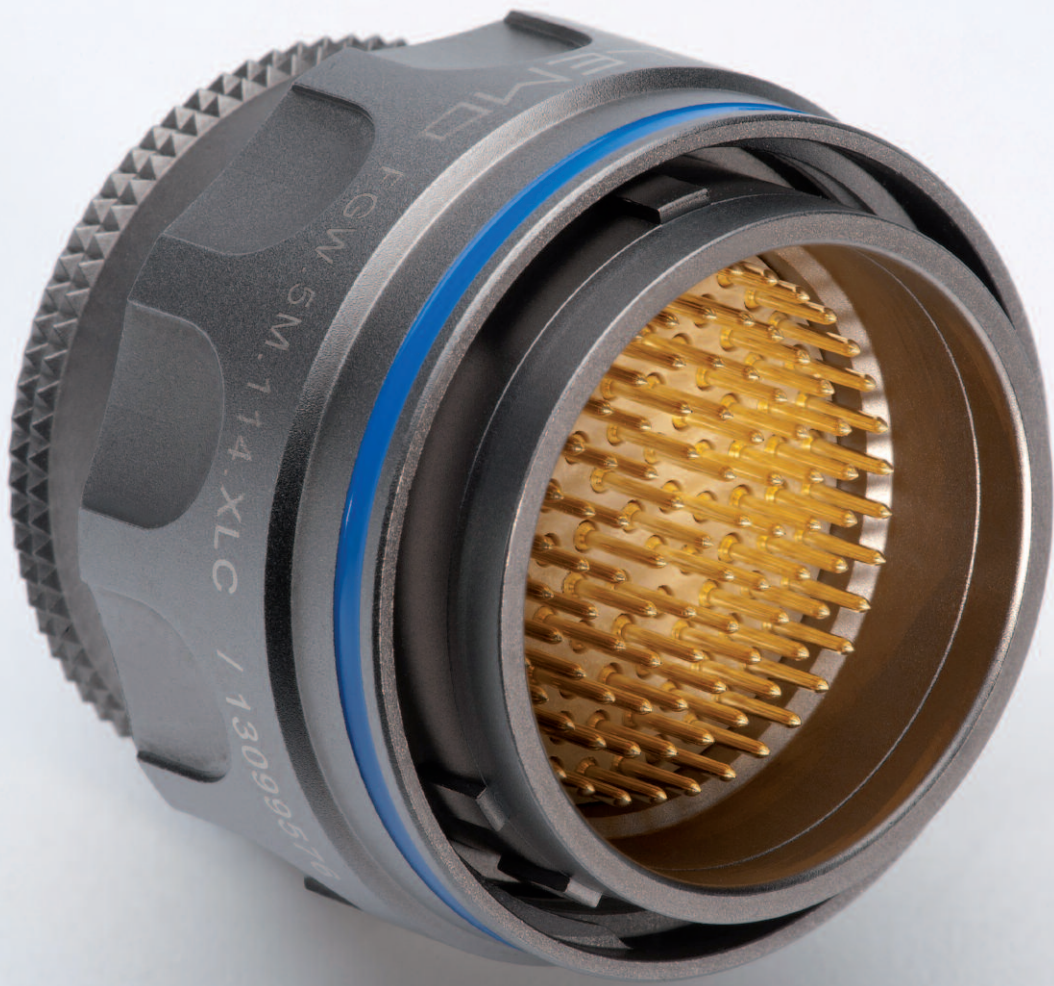

 **LEMO**



## Introduction

This catalogue gives the complete description of LEMO M series connectors. M series connectors are lightweight triple-start ratchet coupling type connectors designed for avionics, aerospace, military, security, motorsport and heavy duty applications.

The LEMO manufacturing programme has been extended to almost 40 series divided into 7 product families with specific mating and environmental characteristics. Each series includes a wide variety of plug, socket and coupler models, available in contact configurations adapted to all round cables. Watertight models are also available. Since LEMO connectors are perfectly screened and designed to guarantee very low resistance to shell electrical continuity, they are particularly adapted to applications where electromagnetic compatibility (EMC) is important.

## Technical Characteristics

### Materials and Treatments

Component	Shell material code		Material (Standard)	Surface treatment (µm)						Notes		
	X	C		chrome			nickel		gold			
				Cu	Ni	Cr	Cu	Ni	Cu		Ni	Au
Outer shell			Brass (UNS C 38500)	0.5	3	0.3	-	-	-	-	-	
			Aluminium alloy (AA 6262A or AA 6023)	-	-	-	-	5	-	-	-	1)
Conical nut			Brass (UNS C 38500)	0.5	3	0.3	-	-	-	-	-	
			Aluminium alloy (AA 6262A or AA 6023)	anodized								
Earthing crown			Bronze (UNS C 54400) or special brass	-	-	-	-	-	0.5	-	1.5	
Coupling nut			Brass (UNS C 38500)	-	-	-	0.5	3	-	-	-	
			Aluminium alloy (AA 6262A or AA 6023)	-	-	-	0.5	3	-	-	-	
Ratchet			Special PEEK	-	-	-	0.5	3	-	-	-	
Hexagonal nut			Brass (UNS C 38500)	-	-	-	0.5	3	-	-	-	
			Aluminium alloy (AA 6262A or AA 6023)	anodized natural								
Male crimp contact			Brass (UNS C 34500)	-	-	-	-	-	0.5	3	1.0	
Female crimp contact			Bronze (UNS C 54400)	-	-	-	-	-	0.5	3	1.5	
Clips			Cu-Be or special steel	without treatment								
Insulator			PEEK	-								
O-ring and gaskets			FPM/FKM (Viton®)	-								
Sealing resin			Epoxy (Araldite® or Stycast®)	-								
Cable rear seal			Fluorosilicone	-								
Spring			Stainless steel	-								

**Notes:** standards for surface treatment are as follows: chrome-plated FS QQ-C-320B; nickel-plated FS QQ-N-290A or MIL-C-26074C; gold-plated ISO 4523. 1) anthracite colour.

### Environmental performance

Characteristics	Value	IEC international	MIL-spec tests
Operating temperature (mated)	- 55°C/+200°C		
Ingress protection index	IP 68 (at 2 m, 15 hr)	IEC 60529	
Fungus	Satisfied - by material analysis		MIL-STD 810F-508.5
Flammability	60 sec. front and back face		EIA-364-104A
Fluid contamination 1)	Fuels, gasoline, hydraulic oils, solvents, de-icing		MIL-STD-810F method 504
Sand and dust 2)	6 hr, 55°C, blowing < 150 µm dust		MIL-STD 810F-510.4
Lightning strike	10 K amps - 6 times		EIA-364-75
Altitude-low temp 3)	-65°C; 40'000 feet and 400 VAC		EIA-364-105A
Salt fog 4)	Alum. shell (slight pitting after 48h), Brass shell (500h)	IEC 60512-6 test 11f	EIA-364-26
Thermal shock	5 cycles: -65°C to +150°C	IEC 60512-11-4	EIA-364-32 test condition IV
Altitude immersion	No moisture on contacts		EIA-364-03
Air leakage 5)	< 10 <sup>-7</sup> mbar. l/sec (Helium)	IEC 60512-7 14 b	MIL-STD-1344 method 1008.1
Humidity	21 days at 95%	IEC 60068-2	EIA-364-31 method IV

#### Note:

- Connectors immersed at both 70°C and 25°C according to specification. Connectors are then inspected, no visual signs of damage seen.  
Fuels: Kerosene, JP4, (Nato F40) at 70°C +/- 2°C. Gasoline: ASTM 4814. Hydraulic oils: Mineral oil based MIL-H-5606.  
Solvents: Isopropanol. De-icing fluids: 25% ethylene glycol.
- No signs of damage, connectors opened and closed without difficulty. Dust or sand was not inside connector.
- Wired mated connectors = no voltage breakdown, shell to all contacts (connected together) w/400 VAC after 1 hour at 65°C at 40'000 feet altitude.
- Corrosion resistance. Inspection: salt deposits shall be removed by gentle wash in running water with light brushing using soft brush.  
Aluminium Shell (material code: X) max: 96 hours. Brass shell (material code: C) over 500 hours.
- Only for vacuumtight model (HE•)

## Electrical performance

Characteristics	Value	IEC international	MIL-spec tests
Insulation resist. (at ambient temp.) <sup>6)</sup>	> 10 <sup>12</sup> Ω, > 10 <sup>10</sup> Ω (after humidity)	IEC 60512-2 test 3a	EIA-364-21
Dielectric withstanding volt. (sea level)	See table page 16-17	IEC 60512-2 test 4a	EIA-364-20
Contact resistance	See table below <sup>7)</sup>	IEC 60512-2 test 2a	EIA-364-06
Current rating	See insulator configuration page 16-17	IEC 60512-3 test 5a	
Shell to shell conductivity	< 1.5 mΩ	IEC 60512-2-6	EIA-364-83
Shielding effectiveness, low frequency	≥ 80 dB up to 1GHz		EIA-364-66
Shielding effectiveness, high frequency	≥ 70 dB (3GHz), ≥ 58 dB (6GHz), ≥ 40 dB (10GHz)		EIA-364-66

**Note:** <sup>6)</sup> After humidity test: 21 days at 95% RH according to IEC 60068-2. Insulation resistance measured between the contacts and contact/shell.

Contact resistance <sup>7)</sup> IEC 60512-2 test 2a				Value
0.5	0.7	0.9	1.3	∅ A (mm)
≤ 8.7	≤ 6.1	≤ 4.8	≤ 3.6	mΩ

**Notes:** <sup>7)</sup> after 5000 mating cycles and the salt spray test according to IEC 60512-6 test 11 f.

## Mechanical performance

Characteristics	Value	IEC international	MIL-spec tests
Endurance	3000 cycles (1000 cycles for 5M series)	IEC 60512-5 test 9a	EIA-364-09
Gunfire vibration	25 to 2000 Hz, 3 axis (Apache helicopter)		MIL-STD-810F method 519.5
Vibration-Sine <sup>8)</sup>	30 g, 3 axis, 12 hr		MIL-STD-202 method 204-G
Vibration-Random	50-2000 Hz, 37.8 g rms-3 axes; 4h amb	IEC 60512-6-4	EIA-364-28 test cond. V letter I
Shock	300 g - 3 msec	IEC 60512-6-3	EIA-364-27 condition D
Acceleration	50 g acceleration		MIL-STD-1344 - 2011-1, A
Contact retention	> 22 N (∅ 0.7 mm), > 30 N (∅ 0.9 mm)	IEC 60512-8 test 15a	
Torque	See table below		

**Note:** <sup>8)</sup> Amplitude: 30G. Frequency: 10 to 2000 Hz. Time per axis: 4 hours (X, Y, Z). No signal discontinuity above 1 μs.

Series	Coupling torque tightning (N.cm)	Coupling torque untightning (N.cm)	Series	Coupling torque tightning (N.cm)	Coupling torque untightning (N.cm)
0M	4	5	TM	tbc	tbc
1M	10	11	4M	26	25
2M	20	14	LM	48	43
3M	34	29	5M	91 <sup>9)</sup>	54

**Note:** <sup>9)</sup> Higher value due to very high contact density

# M Series

The M Series connector offers a new innovative design for avionics, aerospace, military, security, motorsport and heavy duty applications.

Made of high-strength aluminium, this connector is one of the lightest and most compact of the LEMO product line. A one-grip ratchet screw system enables quick and secure coupling of the connectors. The arctic grip makes it easy to manipulate the connector while wearing gloves or when the connector is located in a difficult to access area.

## Features

- Ratchet-coupling mechanism
- Compact design for space savings
- Oil and fuel resistant
- 360° screening for full EMC shielding
- Colour coding / keying
- Scoop proof
- Threaded for MIL-DTL-38999L backshell
- Quick mating: less than 3/4 turn to seat
- Lightweight
- High vibration and shock resistance
- Sealed to IP68 when mated
- Reverse sex configuration
- Pin configuration from 2 to 114 contacts

## Metal housing models (page 5)

### Straight plugs

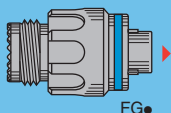
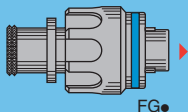
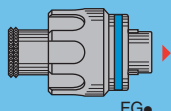
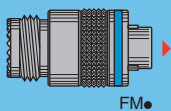
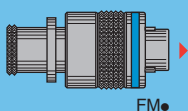
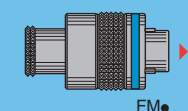

### Fixed sockets

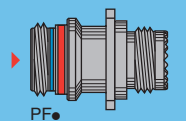
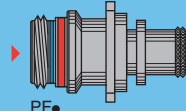
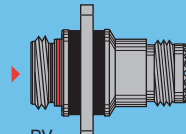
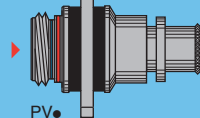
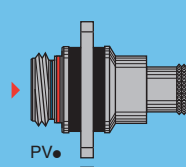
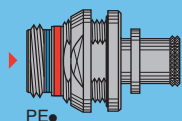
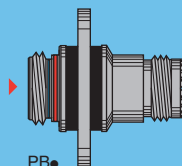
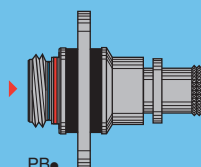
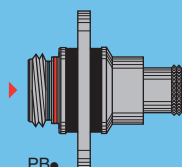
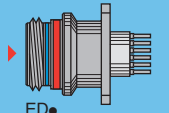
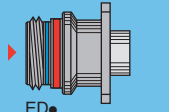
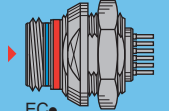
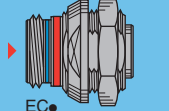
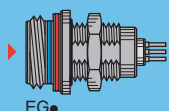
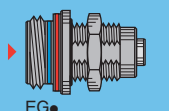

### Free sockets

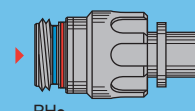
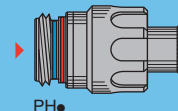
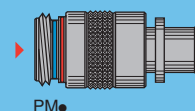
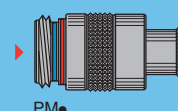

### Watertight model (unmated)

#### Fixed socket

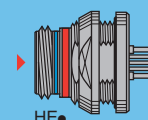

## Part Numbering System

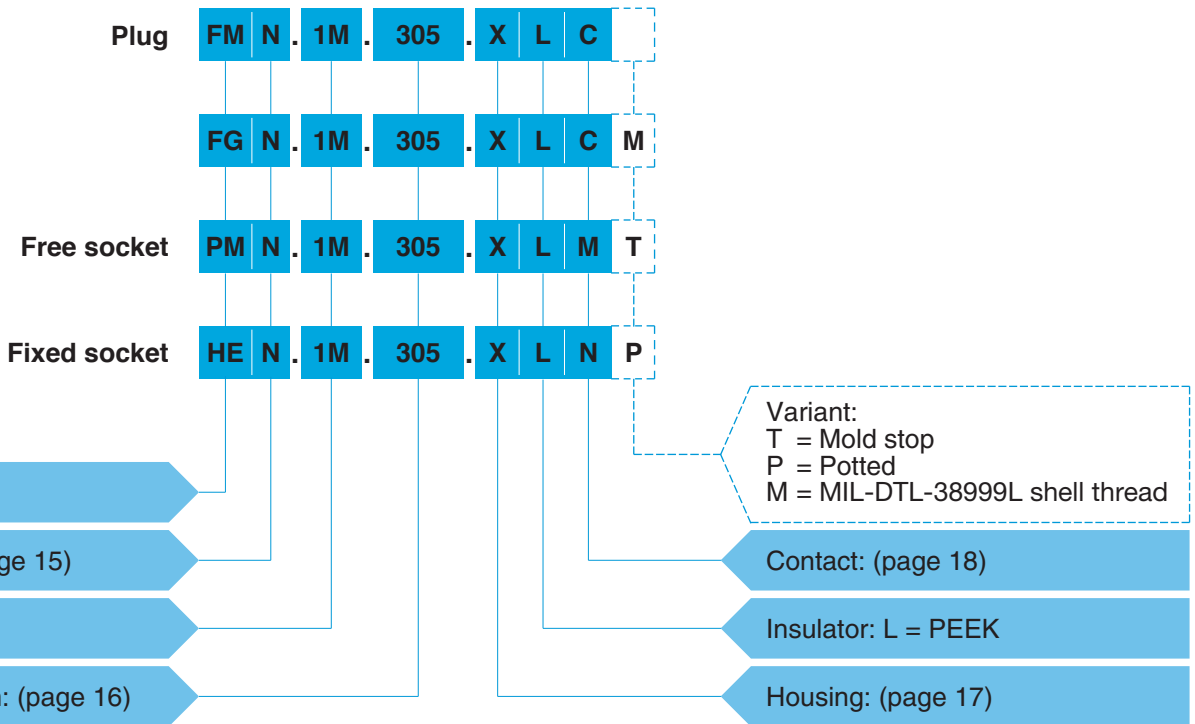

## Part Number Example

### Straight plug:

**FMN.1M.305.XLC** = straight plug with key (N), 1M series, multipole type with 5 contacts, outer shell in anthracite nickel-plated aluminium alloy, PEEK insulator, male crimp contacts.

### Straight plug:

**FGN.1M.305.XLCM** = straight plug with key (N), arctic grip, 1M series, multipole type with 5 contacts, outer shell in anthracite nickel-plated aluminium alloy, PEEK insulator, male crimp contacts and with MIL-DTL-38999L thread for additional backshell (not supplied).

### Free socket:

**PMN.1M.305.XLMT** = free socket with key (N), 1M series, multipole type with 5 contacts, outer shell in anthracite nickel-plated aluminium alloy, PEEK insulator, female crimp contacts and mold stop.

### Fixed socket:

**HEN.1M.305.XLNP** = fixed socket, nut fixing, with key (N), 1M series, multipole type with 5 contacts, outer shell in anthracite nickel-plated aluminium alloy, PEEK insulator, female print contacts, watertight.

## Part Section Showing Internal Components

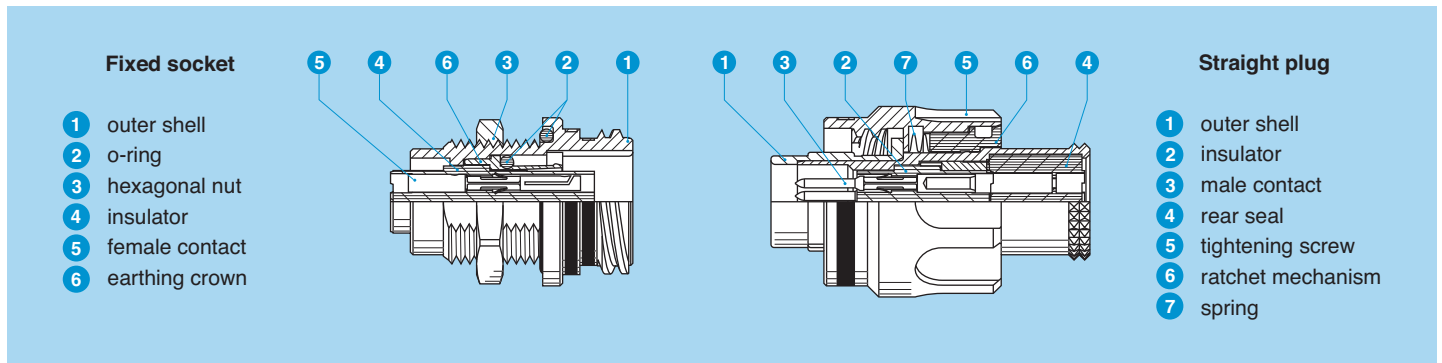

# Metal housing models



**FM● Straight plug, key (N) or keys (P, R, S, T, U, V, W and X) with knurled grip**

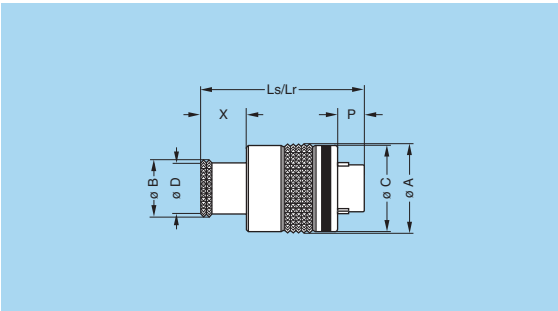

Reference		Dimensions (mm)							
Model	Series	A	B	C	D	Ls	Lr	P	X
FM●	0M	13.1	8.8	12.7	8.0	24.1	24.1	3.9	6.7
FM●	1M	14.6	10.5	14.2	9.7	24.1	24.1	3.9	6.7
FM●	2M	17.6	14.0	17.2	13.0	24.5	24.5	3.9	7.1
FM●	3M	19.6	16.0	19.2	15.0	24.5	24.5	3.9	7.1
FM●	TM	22.5	17.9	22.0	16.7	28.6	28.6	3.4	7.6
FM●	4M	25.0	20.7	24.5	19.5	28.6	28.6	3.4	7.6
FM●	LM	28.5	23.9	28.0	22.7	28.6	28.6	3.4	7.6
FM●	5M	34.0	29.7	33.5	28.5	28.6	28.6	3.4	7.6

Part number example: FMN.1M.305.XLC

Note: Ls = standard gender, Lr = reverse gender



**FM● Straight plug, key (N) or keys (P, R, S, T, U, V, W and X) with knurled grip and mold stop**

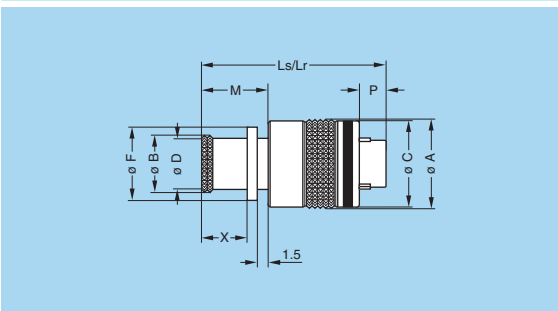

Reference		Dimensions (mm)									
Model	Series	A	B	C	D	F	Ls	Lr	M	P	X
FM●	0M	13.1	8.8	12.7	8.0	10.7	27.1	27.1	9.7	3.9	6.7
FM●	1M	14.6	10.5	14.2	9.7	12.4	27.1	27.1	9.7	3.9	6.7
FM●	2M	17.6	14.0	17.2	13.0	15.5	27.5	27.5	10.1	3.9	7.1
FM●	3M	19.6	16.0	19.2	15.0	17.5	27.5	27.5	10.1	3.9	7.1
FM●	TM	22.5	17.9	22.0	16.7	19.8	31.6	31.6	10.6	3.4	7.6
FM●	4M	25.0	20.7	24.5	19.5	22.6	31.6	31.6	10.6	3.4	7.6
FM●	LM	28.5	23.9	28.0	22.7	25.8	31.6	31.6	10.6	3.4	7.6
FM●	5M	34.0	29.7	33.5	28.5	31.4	31.6	31.6	10.6	3.4	7.6

Part number example: FMN.1M.305.XLCT

Note: Ls = standard gender, Lr = reverse gender



**FM● Straight plug, key (N) or keys (P, R, S, T, U, V, W and X) with MIL-DTL-38999L shell thread**

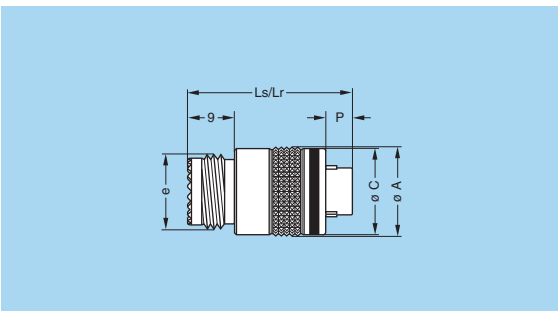

Reference		Dimensions (mm)							Code <sup>1)</sup>
Model	Series	A	C	e	Ls	Lr	P		
FM●	1M	14.6	14.2	M12x1.0	26.4	26.4	3.9	A	
FM●	2M	17.6	17.2	M15x1.0	26.4	26.4	3.9	B	
FM●	3M	19.6	19.2	M18x1.0	26.4	26.4	3.9	C	
FM●	TM	22.5	22.0	M18x1.0	30.0	30.0	3.4	C	
FM●	4M	25.0	24.5	M22x1.0	30.0	30.0	3.4	D	
FM●	LM	28.5	28.0	M25x1.0	30.0	30.0	3.4	E	
FM●	5M	34.0	33.5	M31x1.0	30.0	30.0	3.4	G	

Part number example: FMN.1M.305.XLCM

Note: Ls = standard gender, Lr = reverse gender. <sup>1)</sup> MIL-DTL-38999L shell size code (backshell not supplied)

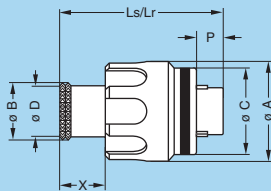

### FG● Straight plug, key (N) or keys (P, R, S, T, U, V, W and X) with arctic grip

Reference		Dimensions (mm)							
Model	Series	A	B	C	D	Ls	Lr	P	X
FG●	0M	14.4	8.8	12.7	8.0	24.1	24.1	3.9	6.7
FG●	1M	15.9	10.5	14.2	9.7	24.1	24.1	3.9	6.7
FG●	2M	18.9	14.0	17.2	13.0	24.5	24.5	3.9	7.1
FG●	3M	20.9	16.0	19.2	15.0	24.5	24.5	3.9	7.1
FG●	TM	23.4	17.9	22.0	16.7	28.6	28.6	3.4	7.6
FG●	4M	25.9	20.7	24.5	19.5	28.6	28.6	3.4	7.6
FG●	LM	29.4	23.9	28.0	22.7	28.6	28.6	3.4	7.6
FG●	5M	34.9	29.7	33.5	28.5	28.6	28.6	3.4	7.6

Part number example: FGN.1M.305.XLC

Note: Ls = standard gender, Lr = reverse gender

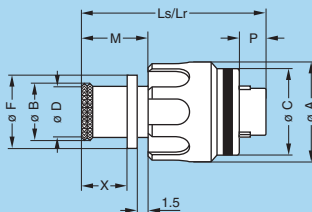

### FG● Straight plug, key (N) or keys (P, R, S, T, U, V, W and X) with arctic grip and mold stop

Reference		Dimensions (mm)									
Model	Series	A	B	C	D	F	Ls	Lr	M	P	X
FG●	0M	14.4	8.8	12.7	8.0	10.7	27.1	27.1	9.7	3.9	6.7
FG●	1M	15.9	10.5	14.2	9.7	12.4	27.1	27.1	9.7	3.9	6.7
FG●	2M	18.9	14.0	17.2	13.0	15.5	27.5	27.5	10.1	3.9	7.1
FG●	3M	20.9	16.0	19.2	15.0	17.5	27.5	27.5	10.1	3.9	7.1
FG●	TM	23.4	17.9	22.0	16.7	19.8	31.6	31.6	10.6	3.4	7.6
FG●	4M	25.9	20.7	24.5	19.5	22.6	31.6	31.6	10.6	3.4	7.6
FG●	LM	29.4	23.9	28.0	22.7	25.8	31.6	31.6	10.6	3.4	7.6
FG●	5M	34.9	29.7	33.5	28.5	31.4	31.6	31.6	10.6	3.4	7.6

Part number example: FGN.1M.305.XLCT

Note: Ls = standard gender, Lr = reverse gender

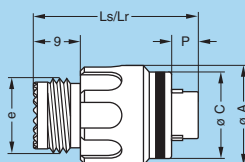

### FG● Straight plug, key (N) or keys (P, R, S, T, U, V, W and X) with arctic grip and with MIL-DTL-38999L shell thread

Reference		Dimensions (mm)						
Model	Series	A	C	e	Ls	Lr	P	Code <sup>1)</sup>
FG●	1M	15.9	14.2	M12x1.0	26.4	26.4	3.9	A
FG●	2M	18.9	17.2	M15x1.0	26.4	26.4	3.9	B
FG●	3M	20.9	19.2	M18x1.0	26.4	26.4	3.9	C
FG●	TM	23.4	22.0	M18x1.0	30.0	30.0	3.4	C
FG●	4M	25.9	24.5	M22x1.0	30.0	30.0	3.4	D
FG●	LM	29.4	28.0	M25x1.0	30.0	30.0	3.4	E
FG●	5M	34.9	33.5	M31x1.0	30.0	30.0	3.4	G

Part number example: FGN.1M.305.XLCM

Note: Ls = standard gender, Lr = reverse gender. <sup>1)</sup> MIL-DTL-38999L shell size code (backshell not supplied)



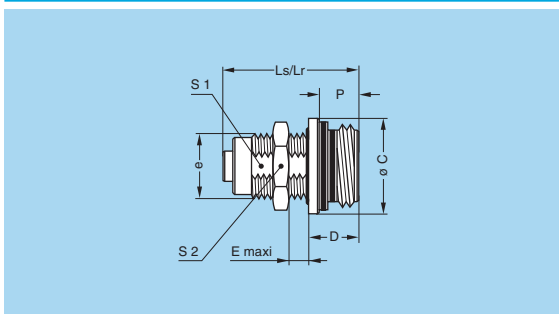

### EG● Fixed socket, nut fixing, key (N) or keys (P, R, S, T, U, V, W and X)

Reference		Dimensions (mm)								
Model	Series	C	D	e	E	Ls	Lr	P	S1	S2
EG●	0M	12.7	6.8	M9x0.6	5.0	18.1	18.1	5.3	8.2	11.0
EG●	1M	14.2	6.8	M11x1.0	4.5	18.1	18.1	5.3	9.5	13.0
EG●	2M	17.2	6.8	M14x1.0	4.5	18.1	18.1	5.3	12.5	17.0
EG●	3M	19.2	6.8	M16x1.0	4.0	18.1	18.1	5.3	14.5	19.0
EG●	TM	22.0	9.4	M18x1.0	4.0	19.8	21.7	7.9	16.5	22.0
EG●	4M	24.5	9.4	M21x1.0	4.0	19.8	21.7	7.9	19.5	25.0
EG●	LM	28.0	9.4	M24x1.0	4.0	19.8	21.7	7.9	22.5	30.0
EG●	5M	33.5	9.4	M30x1.0	4.0	19.8	21.7	7.9	28.5	36.0

Part number example: EGN.1M.305.XLM

Panel cut-out (page 23).

Note: Ls = standard gender, Lr = reverse gender

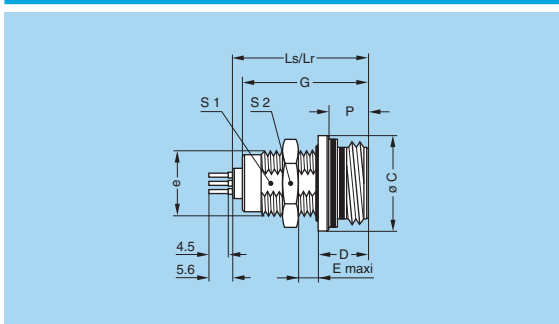

### EG● Fixed socket, nut fixing, key (N) or keys (P, R, S, T, U, V, W and X) for printed circuit

Reference		Dimensions (mm)									
Model	Series	C	D	e	E	G	Ls	Lr	P	S1	S2
EG●	0M	12.7	6.8	M9x0.6	5.0	16.8	18.1	18.1	5.3	8.2	11.0
EG●	1M	14.2	6.8	M11x1.0	4.5	16.8	18.1	18.1	5.3	9.5	13.0
EG●	2M	17.2	6.8	M14x1.0	4.5	16.8	18.1	18.1	5.3	12.5	17.0
EG●	3M	19.2	6.8	M16x1.0	4.0	16.8	18.1	18.1	5.3	14.5	19.0
EG●	TM	22.0	9.4	M18x1.0	4.0	18.9	19.8	21.7	7.9	16.5	22.0
EG●	4M	24.5	9.4	M21x1.0	4.0	18.9	19.8	21.7	7.9	19.5	25.0
EG●	LM	28.0	9.4	M24x1.0	4.0	18.9	19.8	21.7	7.9	22.5	30.0
EG●	5M	33.5	9.4	M30x1.0	4.0	18.9	19.8	21.7	7.9	28.5	36.0

Part number example: EGN.1M.305.XLN

Panel cut-out (page 23).

Note: Ls = standard gender, Lr = reverse gender

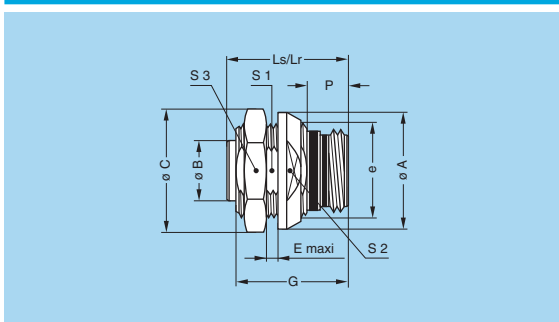

### EC● Fixed socket with two nuts, key (N) or keys (P, R, S, T, U, V, W and X)

Reference		Dimensions (mm)											
Model	Series	A	B	C	E	e	G	Ls	Lr	P	S1	S2	S3
EC●	0M	17	4.72	18.2	5.0	M13x0.75	16.8	18.1	18.1	5.3	11.5	14.0	16.0
EC●	1M	18	5.95	19.2	5.0	M14x1.00	16.8	18.1	18.1	5.3	12.5	16.0	17.0
EC●	2M	21	8.95	21.5	4.0	M17x1.00	16.8	18.1	18.1	5.3	15.5	18.0	19.0
EC●	3M	23	10.95	25.0	4.0	M19x1.00	16.8	18.1	18.1	5.3	17.5	20.0	22.0
EC●	TM	27	12.30	28.0	2.5	M22x1.00	18.9	19.8	21.7	7.9	20.5	23.0	25.0
EC●	4M	29	13.95	34.0	2.5	M24x1.00	18.9	19.8	21.7	7.9	22.5	25.0	30.0
EC●	LM	33	17.95	36.0	2.5	M28x1.00	18.9	19.8	21.7	7.9	26.5	29.0	32.0
EC●	5M	38	22.90	41.0	2.5	M33x1.00	18.9	19.8	21.7	7.9	31.5	34.0	37.0

Part number example: ECN.1M.305.XLM

Panel cut-out (page 23).

Note: Ls = standard gender, Lr = reverse gender

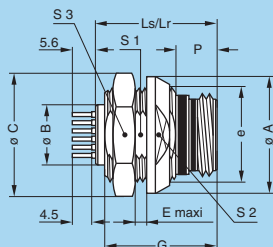

### EC● Fixed socket with two nuts, key (N) or keys (P, R, S, T, U, V, W and X) for printed circuit

Reference		Dimensions (mm)											
Model	Series	A	B	C	E	e	G	Ls	Lr	P	S1	S2	S3
EC●	0M	17	4.72	18.2	5.0	M13x0.75	16.8	18.1	18.1	5.3	11.5	14.0	16.0
EC●	1M	18	5.95	19.2	5.0	M14x1.00	16.8	18.1	18.1	5.3	12.5	16.0	17.0
EC●	2M	21	8.95	21.5	4.0	M17x1.00	16.8	18.1	18.1	5.3	15.5	18.0	19.0
EC●	3M	23	10.95	25.0	4.0	M19x1.00	16.8	18.1	18.1	5.3	17.5	20.0	22.0
EC●	TM	27	12.30	28.0	2.5	M22x1.00	18.9	19.8	21.7	7.9	20.5	23.0	25.0
EC●	4M	29	13.95	34.0	2.5	M24x1.00	18.9	19.8	21.7	7.9	22.5	25.0	30.0
EC●	LM	33	17.95	36.0	2.5	M28x1.00	18.9	19.8	21.7	7.9	26.5	29.0	32.0
EC●	5M	38	22.90	41.0	2.5	M33x1.00	18.9	19.8	21.7	7.9	31.5	34.0	37.0

Part number example: ECN.1M.305.XLN

Panel cut-out (page 23).

Note: Ls = standard gender, Lr = reverse gender

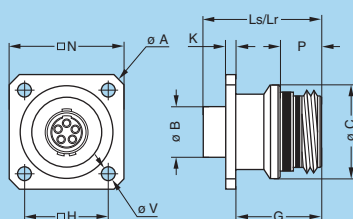
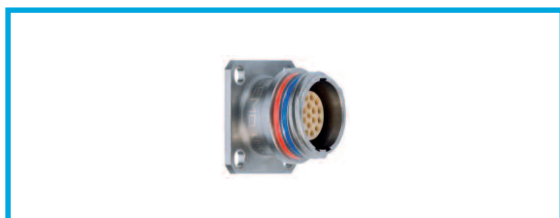

### ED● Fixed socket with square flange, key (N) or keys (P, R, S, T, U, V, W and X)

Reference		Dimensions (mm)										
Model	Series	A	B	C	G	H	K	Ls	Lr	N	P	V
ED●	0M	20.6	4.72	12.7	12.8	11.0	1.5	18.1	18.1	16.0	5.3	2.7
ED●	1M	23.8	5.95	14.2	12.8	12.9	1.5	18.1	18.1	18.4	5.3	3.3
ED●	2M	26.9	8.95	17.2	12.8	15.1	1.5	18.1	18.1	20.6	5.3	3.3
ED●	3M	29.0	10.95	19.2	12.8	16.6	1.5	18.1	18.1	22.1	5.3	3.3
ED●	TM	31.4	12.30	22.0	14.5	18.3	2.0	19.8	21.7	23.8	7.9	3.3
ED●	4M	34.6	13.95	24.5	14.5	20.6	2.0	19.8	21.7	26.1	7.9	3.3
ED●	LM	38.0	17.95	28.0	14.5	23.0	2.0	19.8	21.7	28.5	7.9	3.3
ED●	5M	43.7	22.90	33.5	14.5	27.0	2.0	19.8	21.7	32.5	7.9	3.3

Part number example: EDN.1M.305.XLM

Panel cut-out (page 23).

Note: Ls = standard gender, Lr = reverse gender

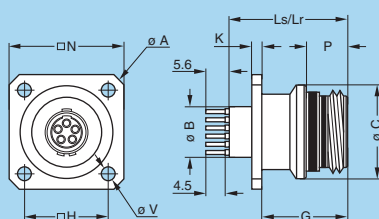

### ED● Fixed socket with square flange, key (N) or keys (P, R, S, T, U, V, W and X) for printed circuit

Reference		Dimensions (mm)										
Model	Series	A	B	C	G	H	K	Ls	Lr	N	P	V
ED●	0M	20.6	4.72	12.7	12.8	11.0	1.5	18.1	18.1	16.0	5.3	2.7
ED●	1M	23.8	5.95	14.2	12.8	12.9	1.5	18.1	18.1	18.4	5.3	3.3
ED●	2M	26.9	8.95	17.2	12.8	15.1	1.5	18.1	18.1	20.6	5.3	3.3
ED●	3M	29.0	10.95	19.2	12.8	16.6	1.5	18.1	18.1	22.1	5.3	3.3
ED●	TM	31.4	12.30	22.0	14.5	18.3	2.0	19.8	21.7	23.8	7.9	3.3
ED●	4M	34.6	13.95	24.5	14.5	20.6	2.0	19.8	21.7	26.1	7.9	3.3
ED●	LM	38.0	17.95	28.0	14.5	23.0	2.0	19.8	21.7	28.5	7.9	3.3
ED●	5M	43.7	22.90	33.5	14.5	27.0	2.0	19.8	21.7	32.5	7.9	3.3

Part number example: EDN.1M.305.XLN

Panel cut-out (page 23).

Note: Ls = standard gender, Lr = reverse gender

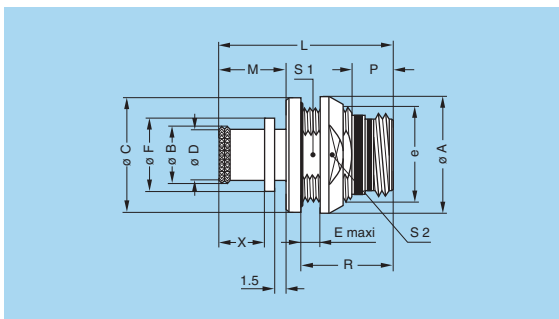

**PE● Fixed socket, nut fixing, key (N) or keys (P, R, S, T, U, V, W and X) and mold stop (back panel mounting)**

Reference		Dimensions (mm)												
Model	Series	A	B	C	D	E	e	Ls	Lr	M	P	R	S1	S2
PE●	0M	17	8.8	16.8	8.0	5.0	M13x0.75	25.6	25.6	9.7	5.3	13.8	11.5	14
PE●	1M	18	10.5	17.8	9.7	5.0	M14x1.00	25.6	25.6	9.7	5.3	13.8	12.5	16
PE●	2M	21	14.0	20.8	13.0	5.0	M17x1.00	26.0	26.0	10.1	5.3	13.8	15.5	18
PE●	3M	23	16.0	22.8	15.0	5.0	M19x1.00	26.0	26.0	10.1	5.3	13.8	17.5	20
PE●	TM	27	17.9	25.8	16.7	4.0	M22x1.00	29.5	30.1	10.6	7.9	16.9	20.5	23
PE●	4M	29	20.7	27.8	19.5	4.0	M24x1.00	29.5	30.1	10.6	7.9	16.9	22.5	25
PE●	LM	33	23.9	31.8	22.7	4.0	M28x1.00	29.5	30.1	10.6	7.9	16.9	26.5	29
PE●	5M	38	29.7	36.8	28.5	4.0	M33x1.00	29.5	30.1	10.6	7.9	16.9	31.5	34

Part number example: PEN.1M.305.XLMT

Panel cut-out (page 23).

Note: this model is only available with mold stop. The dimensions «F» and «X» are the same as the PB● models. Ls = standard gender, Lr = reverse gender.

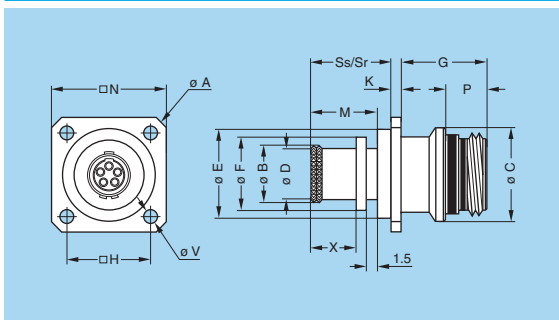

**PF● Fixed socket with square flange, key (N) or keys (P, R, S, T, U, V, W and X) and mold stop**

Reference		Dimensions (mm)												
Model	Series	A	B	C	D	E	F	G	H	K	N	Ss	Sr	V
PF●	0M	20.6	8.8	12.7	8.0	10.7	10.7	12.8	11.0	1.5	16.0	11.3	11.3	2.7
PF●	1M	23.8	10.5	14.2	9.7	12.4	12.4	12.8	12.9	1.5	18.4	11.3	11.3	3.3
PF●	2M	26.9	14.0	17.2	13.0	15.5	15.5	12.8	15.1	1.5	20.6	11.7	11.7	3.3
PF●	3M	29.0	16.0	19.2	15.0	17.5	17.5	12.8	16.6	1.5	22.1	11.7	11.7	3.3
PF●	TM	31.4	17.9	22.0	16.7	19.8	19.8	14.5	18.3	2.0	23.8	13.0	13.6	3.3
PF●	4M	34.6	20.7	24.5	19.5	22.6	22.6	14.5	20.6	2.0	26.1	13.0	13.6	3.3
PF●	LM	38.0	23.9	28.0	22.7	25.8	25.8	14.5	23.0	2.0	28.5	13.0	13.6	3.3
PF●	5M	47.0	29.7	33.5	28.5	33.0	31.4	14.5	29.4	2.0	37.0	13.0	13.6	3.3

Part number example: PFN.1M.305.XLMT

Panel cut-out (page 23).

Note: this model is only available with mold stop. The dimensions «M», «P» and «X» are the same as the PB● models. Ss = standard gender, Sr = reverse gender.

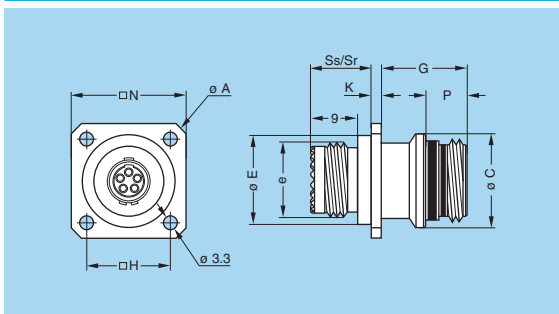

**PF● Fixed socket with square flange, key (N) or keys (P, R, S, T, U, V, W and X) with MIL-DTL-38999L shell thread**

Reference		Dimensions (mm)										
Model	Series	A	C	e	E	G	H	K	N	Ss	Sr	Code <sup>1)</sup>
PF●	1M	23.8	14.2	M12x1.0	12.4	12.8	12.9	1.5	18.4	12.2	12.2	A
PF●	2M	26.9	17.2	M15x1.0	15.5	12.8	15.1	1.5	20.6	12.2	12.2	B
PF●	3M	29.0	19.2	M18x1.0	17.5	12.8	16.6	1.5	22.1	12.2	12.2	C
PF●	TM	31.4	22.0	M18x1.0	19.8	14.5	18.3	2.0	23.8	11.7	13.6	C
PF●	4M	34.6	24.5	M22x1.0	22.6	14.5	20.6	2.0	26.1	11.7	13.6	D
PF●	LM	38.0	28.0	M25x1.0	25.8	14.5	23.0	2.0	28.5	11.7	13.6	E
PF●	5M	47.0	33.5	M31x1.0	33.0	14.5	29.4	2.0	37.0	11.7	13.6	G

Part number example: PFN.1M.305.XLMM

Panel cut-out (page 23).

Note: Ss = standard gender, Sr = reverse gender. <sup>1)</sup> MIL-DTL-38999L shell size code (backshell not supplied)

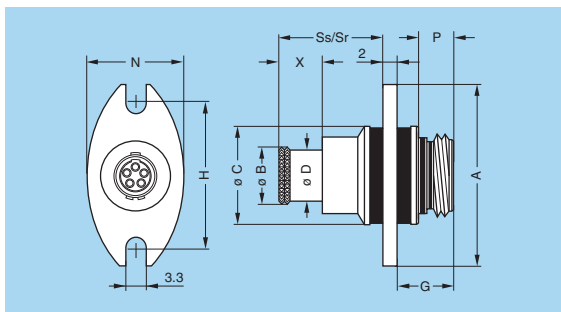

**PB● Fixed socket with antivibration flange, key (N) or keys (P, R, S, T, U, V, W and X), 2 holes fixing**

Reference		Dimensions (mm)										
Model	Series	A	B	C	D	G	H	N	P	Ss	Sr	X
PB●	0M	27.0	8.8	14.5	8.0	8.3	21.4	16.0	5.3	15.3	15.3	6.7
PB●	1M	29.0	10.5	16.5	9.7	8.3	23.4	18.0	5.3	15.3	15.3	6.7
PB●	2M	32.0	14.0	19.5	13.0	8.3	26.4	21.0	5.3	15.7	15.7	7.1
PB●	3M	35.0	16.0	21.5	15.0	8.3	29.0	23.0	5.3	15.7	15.7	7.1
PB●	TM	38.5	17.9	24.5	16.7	11.0	32.5	26.0	7.9	15.2	17.1	7.6
PB●	4M	41.0	20.7	27.5	19.5	11.0	35.0	29.0	7.9	15.2	17.1	7.6
PB●	LM	44.0	23.9	30.5	22.7	11.0	38.0	32.0	7.9	15.2	17.1	7.6
PB●	5M	51.0	29.7	37.5	28.5	11.0	45.0	39.0	7.9	15.2	17.1	7.6

Part number example: PBN.1M.305.XLM

Panel cut-out (page 23).

Note: Ss = standard gender, Sr = reverse gender

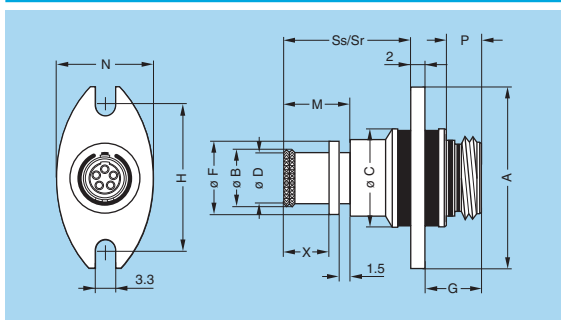

**PB● Fixed socket with antivibration flange, key (N) or keys (P, R, S, T, U, V, W and X), 2 holes fixing and mold stop**

Reference		Dimensions (mm)												
Model	Series	A	B	C	D	F	G	H	M	N	P	Ss	Sr	X
PB●	0M	27.0	8.8	14.5	8.0	10.7	8.3	21.4	9.7	16	5.3	18.3	18.3	6.7
PB●	1M	29.0	10.5	16.5	9.7	12.4	8.3	23.4	9.7	18	5.3	18.3	18.3	6.7
PB●	2M	32.0	14.0	19.5	13.0	15.5	8.3	26.4	10.1	21	5.3	18.7	18.7	7.1
PB●	3M	35.0	16.0	21.5	15.0	17.5	8.3	29.0	10.1	23	5.3	18.7	18.7	7.1
PB●	TM	38.5	17.9	24.5	16.7	19.8	11.0	32.5	10.6	26	7.9	18.2	18.2	7.6
PB●	4M	41.0	20.7	27.5	19.5	22.6	11.0	35.0	10.6	29	7.9	18.2	18.2	7.6
PB●	LM	44.0	23.9	30.5	22.7	25.8	11.0	38.0	10.6	32	7.9	18.2	18.2	7.6
PB●	5M	51.0	29.7	37.5	28.5	31.4	11.0	45.0	10.6	39	7.9	18.2	18.2	7.6

Part number example: PBN.1M.305.XLMT

Panel cut-out (page 23).

Note: Ss = standard gender, Sr = reverse gender

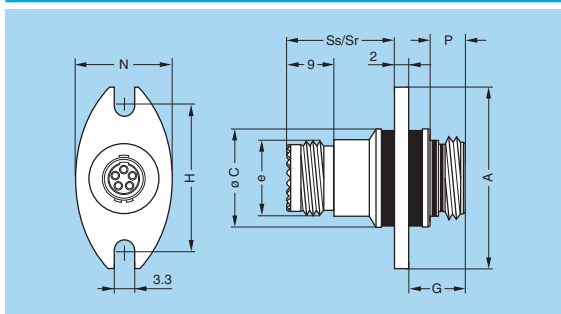

**PB● Fixed socket with antivibration flange, key (N) or keys (P, R, S, T, U, V, W and X), 2 holes fixing with MIL-DTL-38999L shell thread**

Reference		Dimensions (mm)									
Model	Series	A	C	e	G	H	N	P	Ss	Sr	Code <sup>1)</sup>
PB●	1M	29.0	16.5	M12x1.0	8.3	23.4	18.0	5.3	17.2	17.2	A
PB●	2M	32.0	19.5	M15x1.0	8.3	26.4	21.0	5.3	17.2	17.2	B
PB●	3M	35.0	21.5	M18x1.0	8.3	29.0	23.0	5.3	17.2	17.2	C
PB●	TM	38.5	24.5	M18x1.0	11.0	32.5	26.0	7.9	16.2	17.1	C
PB●	4M	41.0	27.5	M22x1.0	11.0	35.0	29.0	7.9	16.2	17.1	D
PB●	LM	44.0	30.5	M25x1.0	11.0	38.0	32.0	7.9	16.2	17.1	E
PB●	5M	51.0	37.5	M31x1.0	11.0	45.0	39.0	7.9	16.2	17.1	G

Part number example: PBN.1M.305.XLMM

Panel cut-out (page 23).

Note: Ss = standard gender, Sr = reverse gender. <sup>1)</sup> MIL-DTL-38999L shell size code (backshell not supplied)

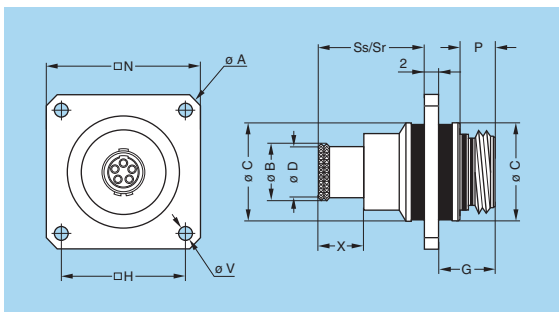
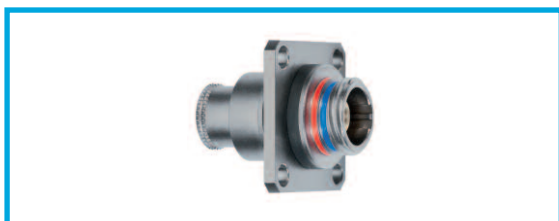

**PV● Fixed socket with antivibration square flange, key (N) or keys (P, R, S, T, U, V, W and X)**

Reference		Dimensions (mm)											
Model	Series	A	B	C	D	G	H	N	P	Ss	Sr	V	X
PV●	0M	26.9	8.8	14.5	8.0	8.3	15.1	20.6	5.3	15.3	15.3	2.7	6.7
PV●	1M	31.4	10.5	16.5	9.7	8.3	18.3	23.8	5.3	15.3	15.3	3.3	6.7
PV●	2M	34.6	14.0	19.5	13.0	8.3	20.6	26.1	5.3	15.7	15.7	3.3	7.1
PV●	3M	38.0	16.0	21.5	15.0	8.3	23.0	28.5	5.3	15.7	15.7	3.3	7.1
PV●	TM	40.3	17.9	24.5	16.7	11.0	24.6	30.1	7.9	15.2	17.1	3.3	7.6
PV●	4M	43.7	20.7	27.5	19.5	11.0	27.0	32.5	7.9	15.2	17.1	3.3	7.6
PV●	LM	47.1	23.9	30.5	22.7	11.0	29.4	34.9	7.9	15.2	17.1	3.3	7.6
PV●	5M	54.9	29.7	37.5	28.5	11.0	34.9	40.4	7.9	15.2	17.1	3.3	7.6

Part number example: PVN.1M.305.XLM

Panel cut-out (page 23).

Note: Ss = standard gender, Sr = reverse gender

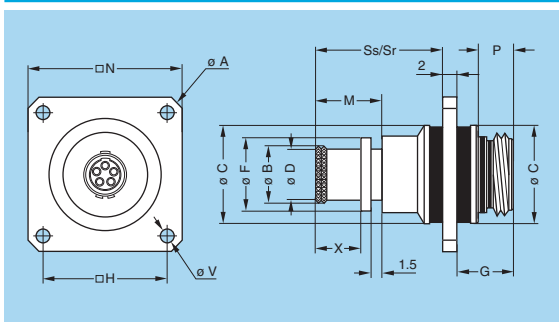
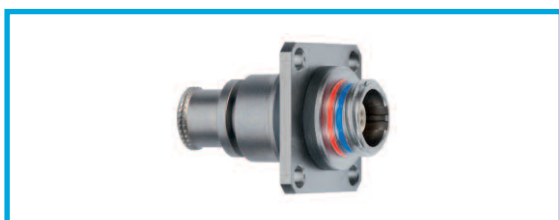

**PV● Fixed socket with antivibration square flange, key (N) or keys (P, R, S, T, U, V, W and X) and mold stop**

Reference		Dimensions (mm)												
Model	Series	A	B	C	D	F	G	H	M	N	P	Ss	Sr	X
PV●	0M	26.9	8.8	14.5	8.0	10.7	8.3	15.1	9.7	20.6	5.3	18.3	18.3	6.7
PV●	1M	31.4	10.5	16.5	9.7	12.4	8.3	18.3	9.7	23.8	5.3	18.3	18.3	6.7
PV●	2M	34.6	14.0	19.5	13.0	15.5	8.3	20.6	10.1	26.1	5.3	18.7	18.7	7.1
PV●	3M	38.0	16.0	21.5	15.0	17.5	8.3	23.0	10.1	28.5	5.3	18.7	18.7	7.1
PV●	TM	40.3	17.9	24.5	16.7	19.8	11.0	24.6	10.6	30.1	7.9	18.2	18.2	7.6
PV●	4M	43.7	20.7	27.5	19.5	22.6	11.0	27.0	10.6	32.5	7.9	18.2	18.2	7.6
PV●	LM	47.1	23.9	30.5	22.7	25.8	11.0	29.4	10.6	34.9	7.9	18.2	18.2	7.6
PV●	5M	54.9	29.7	37.5	28.5	31.4	11.0	34.9	10.6	40.4	7.9	18.2	18.2	7.6

Part number example: PVN.1M.305.XLMT

Panel cut-out (page 23).

Note: Ss = standard gender, Sr = reverse gender. The dimension «V» is the same as the PV● models without mold stop.

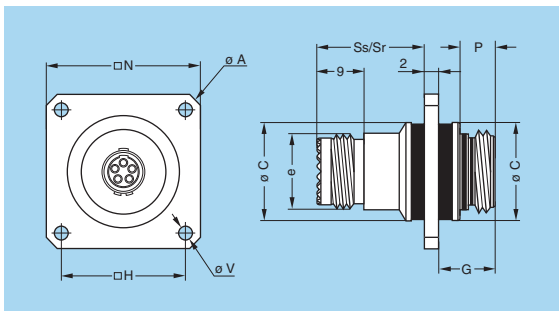
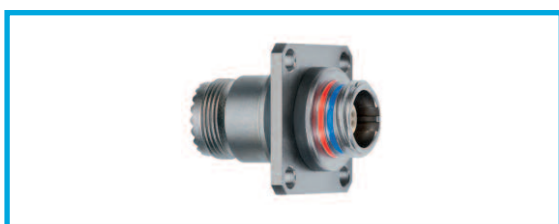

**PV● Fixed socket with antivibration square flange, key (N) or keys (P, R, S, T, U, V, W and X) with MIL-DTL-38999L shell thread**

Reference		Dimensions (mm)										
Model	Series	A	C	e	G	H	N	P	Ss	Sr	V	Code <sup>1)</sup>
PV●	1M	31.4	16.5	M12x1.0	8.3	18.3	23.8	5.3	17.2	17.2	3.3	A
PV●	2M	34.6	19.5	M15x1.0	8.3	20.6	26.1	5.3	17.2	17.2	3.3	B
PV●	3M	38.0	21.5	M18x1.0	8.3	23.0	28.5	5.3	17.2	17.2	3.3	C
PV●	TM	40.3	24.5	M18x1.0	11.0	24.6	30.1	7.9	16.2	17.1	3.3	C
PV●	4M	43.7	27.5	M22x1.0	11.0	27.0	32.5	7.9	16.2	17.1	3.3	D
PV●	LM	47.1	30.5	M25x1.0	11.0	29.4	34.9	7.9	16.2	17.1	3.3	E
PV●	5M	54.9	37.5	M31x1.0	11.0	34.9	40.4	7.9	16.2	17.1	3.3	G

Part number example: PVN.1M.305.XLMM

Panel cut-out (page 23).

Note: Ss = standard gender, Sr = reverse gender. <sup>1)</sup> MIL-DTL-38999L shell size code (backshell not supplied)

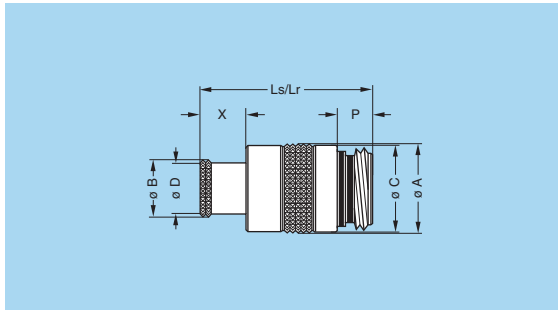

**PM● Free socket, key (N) or keys (P, R, S, T, U, V, W and X) with knurled grip**

Reference		Dimensions (mm)							
Model	Series	A	B	C	D	Ls	Lr	P	X
PM●	0M	13.1	8.8	12.7	8.0	25.6	25.6	5.3	6.7
PM●	1M	14.6	10.5	14.2	9.7	25.6	25.6	5.3	6.7
PM●	2M	17.6	14.0	17.2	13.0	26.0	26.0	5.3	7.1
PM●	3M	19.6	16.0	19.2	15.0	26.0	26.0	5.3	7.1
PM●	TM	22.5	17.9	22.0	16.7	28.2	30.1	7.9	7.6
PM●	4M	25.0	20.7	24.5	19.5	28.2	30.1	7.9	7.6
PM●	LM	28.5	23.9	28.0	22.7	28.2	30.1	7.9	7.6
PM●	5M	34.0	29.7	33.5	28.5	28.2	30.1	7.9	7.6

Part number example: PMN.1M.305.XLM

Panel cut-out (page 23).

Note: Ls = standard gender, Lr = reverse gender

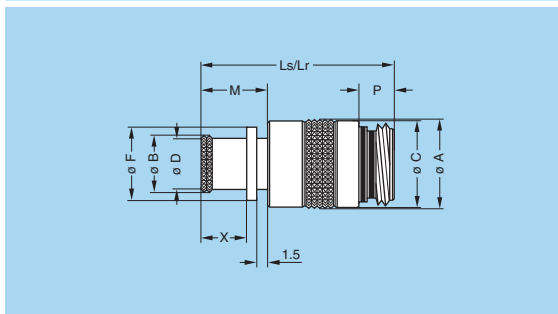

**PM● Free socket, key (N) or keys (P, R, S, T, U, V, W and X) with knurled grip and mold stop**

Reference		Dimensions (mm)									
Model	Series	A	B	C	D	F	Ls	Lr	M	P	X
PM●	0M	13.1	8.8	12.7	8.0	10.7	28.6	28.6	9.7	5.3	6.7
PM●	1M	14.6	10.5	14.2	9.7	12.4	28.6	28.6	9.7	5.3	6.7
PM●	2M	17.6	14.0	17.2	13.0	15.5	29.0	29.0	10.1	5.3	7.1
PM●	3M	19.6	16.0	19.2	15.0	17.5	29.0	29.0	10.1	5.3	7.1
PM●	TM	22.5	17.9	22.0	16.7	19.8	31.2	31.2	10.6	7.9	7.6
PM●	4M	25.0	20.7	24.5	19.5	22.6	31.2	31.2	10.6	7.9	7.6
PM●	LM	28.5	23.9	28.0	22.7	25.8	31.2	31.2	10.6	7.9	7.6
PM●	5M	34.0	29.7	33.5	28.5	31.4	31.2	31.2	10.6	7.9	7.6

Part number example: PMN.1M.305.XLMT

Panel cut-out (page 23).

Note: Ls = standard gender, Lr = reverse gender

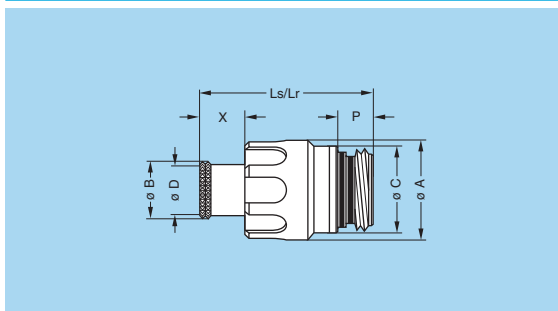

**PH● Free socket, key (N) or keys (P, R, S, T, U, V, W and X) with arctic grip**

Reference		Dimensions (mm)							
Model	Series	A	B	C	D	Ls	Lr	P	X
PH●	0M	14.4	8.8	12.7	8.0	25.6	25.6	5.3	6.7
PH●	1M	15.9	10.5	14.2	9.7	25.6	25.6	5.3	6.7
PH●	2M	18.9	14.0	17.2	13.0	26.0	26.0	5.3	7.1
PH●	3M	20.9	16.0	19.2	15.0	26.0	26.0	5.3	7.1
PH●	TM	23.4	17.9	22.0	16.7	28.2	30.1	7.9	7.6
PH●	4M	25.9	20.7	24.5	19.5	28.2	30.1	7.9	7.6
PH●	LM	29.4	23.9	28.0	22.7	28.2	30.1	7.9	7.6
PH●	5M	34.9	29.7	33.5	28.5	28.2	30.1	7.9	7.6

Part number example: PHN.1M.305.XLM

Panel cut-out (page 23).

Note: Ls = standard gender, Lr = reverse gender

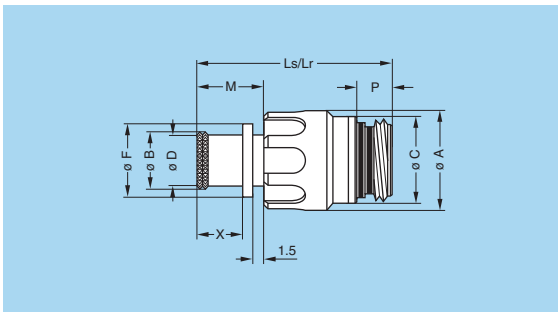

**PH● Free socket, key (N) or keys (P, R, S, T, U, V, W and X) with arctic grip and mold stop**

Reference		Dimensions (mm)									
Model	Series	A	B	C	D	F	Ls	Lr	M	P	X
PH●	0M	14.4	8.8	12.7	8.0	10.7	28.6	28.6	9.7	5.3	6.7
PH●	1M	15.9	10.5	14.2	9.7	12.4	28.6	28.6	9.7	5.3	6.7
PH●	2M	18.9	14.0	17.2	13.0	15.5	29.0	29.0	10.1	5.3	7.1
PH●	3M	20.9	16.0	19.2	15.0	17.5	29.0	29.0	10.1	5.3	7.1
PH●	TM	23.4	17.9	22.0	16.7	19.8	31.2	31.2	10.6	7.9	7.6
PH●	4M	25.9	20.7	24.5	19.5	22.6	31.2	31.2	10.6	7.9	7.6
PH●	LM	29.4	23.9	28.0	22.7	25.8	31.2	31.2	10.6	7.9	7.6
PH●	5M	34.9	29.7	33.5	28.5	31.4	31.2	31.2	10.6	7.9	7.6

**Part number example:** PHN.1M.305.XLMT

Panel cut-out (page 23).

**Note:** Ls = standard gender, Lr = reverse gender

**Watertight model (unmated)**

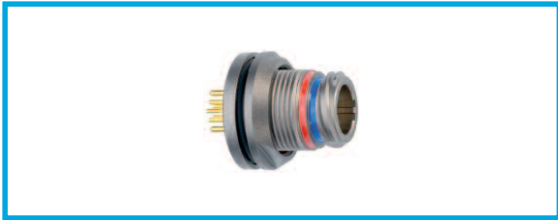

**HE● Fixed socket, nut fixing, key (N) or keys (P, R, S, T, U, V, W and X) for printed circuit, watertight (back panel mounting)**

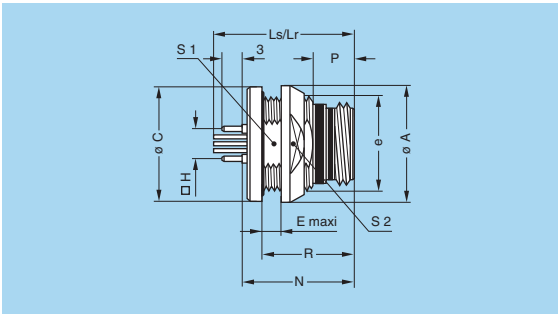

Reference		Dimensions (mm)											
Model	Series	A	C	e	E	H	Ls	Lr	N	P	R	S1	S2
HE●	0M	17	16.8	M13x0.75	5.0	5.08	20.8	21.0	16.8	5.3	13.8	11.5	14
HE●	1M	18	17.8	M14x1.00	5.0	7.62	20.8	21.0	16.8	5.3	13.8	12.5	16
HE●	2M	21	20.8	M17x1.00	5.0	8.89	20.8	21.0	16.8	5.3	13.8	15.5	18
HE●	3M	23	22.8	M19x1.00	5.0	10.16	20.8	21.0	16.8	5.3	13.8	17.5	20
HE●	TM	27	25.8	M22x1.00	4.0	12.70	24.6	24.6	19.9	7.9	16.9	20.5	23
HE●	4M	29	27.8	M24x1.00	4.0	13.97	24.6	24.6	19.9	7.9	16.9	22.5	25
HE●	LM	33	31.8	M28x1.00	4.0	16.51	24.6	24.6	19.9	7.9	16.9	26.5	29
HE●	5M	38	36.8	M33x1.00	4.0	20.32	24.6	24.6	19.9	7.9	16.9	31.5	34

**Part number example:** HEN.1M.305.XLNP

Panel cut-out (page 23). PCB drilling pattern (page 24).

**Note:** Ls = standard gender, Lr = reverse gender



# Alignment Key

## Alignment Key and Polarized Keying System

M series connector model part numbers are composed of three letters. The LAST LETTER indicates the keys corresponding to a particular contact type.

For example, straight plugs with N, P, R, U or W keys, are fitted with male contacts; whereas with S, T, V or X keys, plugs are fitted with female contacts. Sockets with N, P, R, U or W keys, are fitted with female contacts; whereas with S, T, V or X keys, sockets are fitted with male contacts.

	Front view of a socket	Model	Nb of keys	Angles				Colour code	Contact type	
				$\beta$	$\gamma$				Plug	Socket
0M to 3M		●●N	3	165°	30°		blue	male	female	
		●●P		150°	60°		yellow			
		●●U		130°	100°		green			
		●●S		155°	50°		red	female	male	
		●●T		135°	90°		orange			
TM to 5M		●●W	5	95°	115°	35°	25°	blue	male	female
		●●R		105°	115°	30°	20°	yellow		
		●●X		100°	125°	40°	20°	red	female	male
		●●V		110°	120°	35°	25°	orange		



## Insert configuration

### Multipole

	 Male crimp contacts for plug	 Female crimp contacts for sockets	Reference	Number of contacts	ø A (mm)	Contact type		AWG	Test voltage (kV rms) <sup>1)</sup> Contact-contact	Test voltage (kV rms) <sup>1)</sup> Contact-shell	Rated current (A) <sup>1)</sup>
						Crimp	Print (straight) <sup>2)</sup>				
<b>0M</b>			302	2	0.9	●	●	20-22-24	1.45	1.00	10.0
			303	3	0.9	●	●	20-22-24	1.70	1.40	8.0
			304	4	0.7	●	●	22-24-26	1.35	0.90	7.0
			305	5	0.7	●	●	22-24-26	1.25	1.00	6.5
<b>1M</b>			305	5	0.9	●	●	20-22-24	1.30	1.30	9.0
			307	7	0.7	●	●	22-24-26	1.45	1.20	7.0
			308	8	0.7	●	●	22-24-26	1.30	1.10	5.0
<b>2M</b>			308	8	0.9	●	●	20-22-24	1.95	1.10	10.0
			310	10	0.9	●	●	20-22-24	1.80	1.20	8.0
			312	12	0.7	●	●	22-24-26	1.65	1.15	7.0
			319	19	0.7	●	●	22-24-26	1.20	1.00	4.0
<b>3M</b>			322	22	0.7	●	●	22-24-26	tbd	tbd	tbd
			330	30	0.7	●	●	22-24-26	1.10	1.00	3.5
<b>TM</b>			325	25	0.9	●	●	20-22-24	tbd	tbd	tbd
			340	40	0.7	●	●	22-24-26	tbd	tbd	tbd

Note: <sup>1)</sup> Test voltage according to IEC 60512-2 test 4a. <sup>2)</sup> For EG●, EC●, ED●, HE● socket.

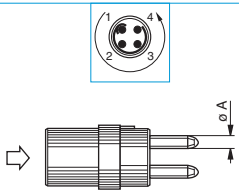
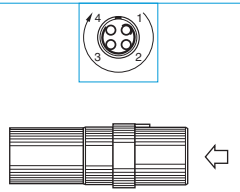
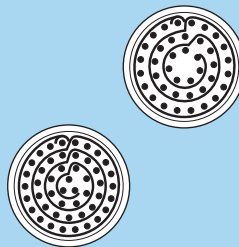
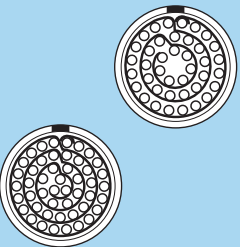
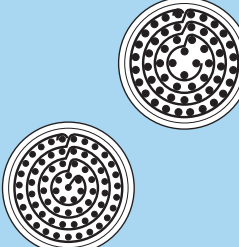
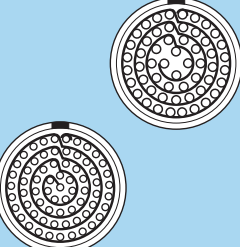
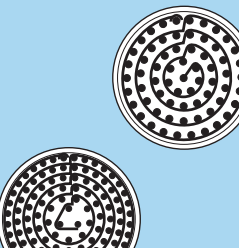
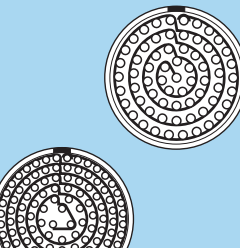

## Multipole

	 Male crimp contacts for plug	 Female crimp contacts for sockets	Reference	Number of contacts	ø A (mm)	Contact type		AWG	Test voltage (kV rms) <sup>1)</sup> Contact-contact	Test voltage (kV rms) <sup>1)</sup> Contact-shell	Rated current (A) <sup>1)</sup>
						Crimp	Print (straight) <sup>2)</sup>				
4M			340	40	0.7	●	●	22-24-26	1.20	1.35	3.5
			348	48	0.7	●	●	22-24-26	1.10	1.35	3.0
LM			355	55	0.9	●	●	20-22-24	tbd	tbd	tbd
			368	68	0.7	●	●	22-24-26	tbd	tbd	tbd
5M			366	66	0.9	●	●	20-22-24	tbd	tbd	tbd
			114	114	0.7	●	●	22-24-26	1.37	1.34	2.0

Note: <sup>1)</sup> Test voltage according to IEC 60512-2 test 4a. <sup>2)</sup> For EG•, EC•, ED•, HE• socket.

## Housings

Ref.	Outer shell	
	Material	Surface treatment
C	Brass	Chrome
X	Aluminium alloy	Nickel <sup>1)</sup>

Note: <sup>1)</sup> anthracite colour.



## Contacts

### Crimp contacts for plugs, free or fixed sockets

There are 2 forms of crimp barrels:

- per fig. 1, the standard design
- per fig. 2, with reduced crimp barrel for small conductors.

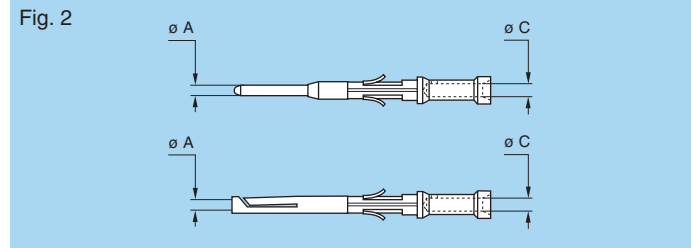
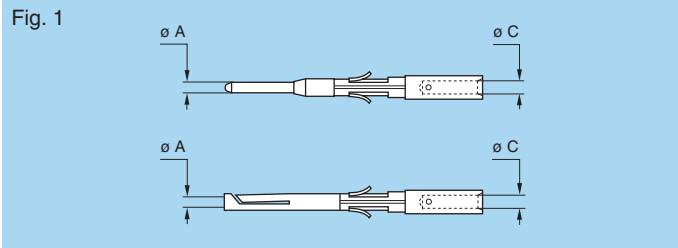

Ref.	Contact type	Ref.	Contact type
C	Male crimp (fig. 1)	M	Female crimp (fig. 1)
B	Male crimp (fig. 2)	P	Female crimp (fig. 2)
D	Male straight print	N	Female straight print

### Dimension of crimp barrels

	Type	Contact			Ref. contact type		Conductor				Part number	
		ø A (mm)	ø C (mm)	Form per fig.	Male	Female	AWG		Section (mm <sup>2</sup> )		For male contacts	For female contacts
							min.	max.	min.	max.		
<b>0M</b>	302-303	0.9	1.10	1	C	M	24	20	0.204	0.616	FGN.0M.560.ZZC	EGN.0M.660.ZZM
		0.9	0.87	2	B	P	26	22	0.128	0.382	FGN.0M.561.ZZC	EGN.0M.661.ZZM
	304-305	0.7	0.87	1	C	M	26	22	0.128	0.382	FGN.0M.555.ZZC	EGN.0M.655.ZZM
		0.7	0.44	2	B	P	32	28	0.032	0.092	FGN.0M.556.ZZC	EGN.0M.656.ZZM
<b>1M</b>	305	0.9	1.10	1	C	M	24	20	0.204	0.616	FGN.0M.560.ZZC	EGN.0M.660.ZZM
		0.9	0.87	2	B	P	26	22	0.128	0.382	FGN.0M.561.ZZC	EGN.0M.661.ZZM
	307-308	0.7	0.87	1	C	M	26	22	0.128	0.382	FGN.0M.555.ZZC	EGN.0M.655.ZZM
		0.7	0.44	2	B	P	32	28	0.032	0.092	FGN.0M.556.ZZC	EGN.0M.656.ZZM
<b>2M</b>	308-310	0.9	1.10	1	C	M	24	20	0.204	0.616	FGN.0M.560.ZZC	EGN.0M.660.ZZM
		0.9	0.87	2	B	P	26	22	0.128	0.382	FGN.0M.561.ZZC	EGN.0M.661.ZZM
	312-319	0.7	0.87	1	C	M	26	22	0.128	0.382	FGN.0M.555.ZZC	EGN.0M.655.ZZM
		0.7	0.44	2	B	P	32	28	0.032	0.092	FGN.0M.556.ZZC	EGN.0M.656.ZZM
<b>3M</b>	322-330	0.7	0.87	1	C	M	26	22	0.128	0.382	FGN.0M.555.ZZC	EGN.0M.655.ZZM
		0.7	0.44	2	B	P	32	28	0.032	0.092	FGN.0M.556.ZZC	EGN.0M.656.ZZM
<b>TM</b>	325	0.9	1.10	1	C	M	24	20	0.204	0.616	FGN.0M.560.ZZC	EGW.TM.660.ZZM
		0.9	0.87	2	B	P	26	22	0.128	0.382	FGN.0M.561.ZZC	EGW.TM.661.ZZM
	340	0.7	0.87	1	C	M	26	22	0.128	0.382	FGN.0M.555.ZZC	EGW.TM.655.ZZM
		0.7	0.44	2	B	P	32	28	0.032	0.092	FGN.0M.556.ZZC	EGW.TM.656.ZZM
<b>4M</b>	340-348	0.7	0.87	1	C	M	26	22	0.128	0.382	FGN.0M.555.ZZC	EGW.TM.655.ZZM
		0.7	0.44	2	B	P	32	28	0.032	0.092	FGN.0M.556.ZZC	EGW.TM.656.ZZM
<b>LM</b>	355	0.9	1.10	1	C	M	24	20	0.204	0.616	FGN.0M.560.ZZC	EGW.TM.660.ZZM
		0.9	0.87	2	B	P	26	22	0.128	0.382	FGN.0M.561.ZZC	EGW.TM.661.ZZM
	368	0.7	0.87	1	C	M	26	22	0.128	0.382	FGN.0M.555.ZZC	EGW.TM.655.ZZM
		0.7	0.44	2	B	P	32	28	0.032	0.092	FGN.0M.556.ZZC	EGW.TM.656.ZZM
<b>5M</b>	366	0.9	1.10	1	C	M	24	20	0.204	0.616	FGN.0M.560.ZZC	EGW.TM.660.ZZM
		0.9	0.87	2	B	P	26	22	0.128	0.382	FGN.0M.561.ZZC	EGW.TM.661.ZZM
	114	0.7	0.87	1	C	M	26	22	0.128	0.382	FGN.0M.555.ZZC	EGW.TM.655.ZZM
		0.7	0.44	2	B	P	32	28	0.032	0.092	FGN.0M.556.ZZC	EGW.TM.656.ZZM

**Note:** according to IEC 60352-2 standard, it is strongly not recommended to crimp monostrand cables.

## Accessories

### BMF Blanking caps for plugs

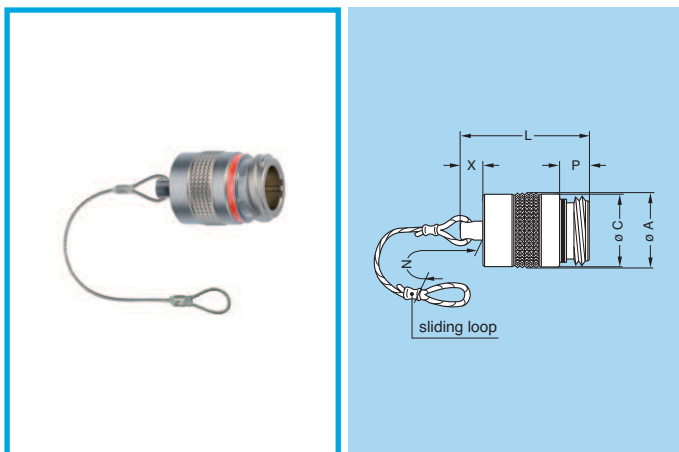

Part number	Dimensions (mm)					
	A	C	L	N	P	X
BMF.0M.100.XAV	13.1	12.7	24.6	85.0	5.3	6.0
BMF.1M.100.XAV	14.6	14.2	24.6	85.0	5.3	6.0
BMF.2M.100.XAV	17.6	17.2	24.6	85.0	5.3	6.0
BMF.3M.100.XAV	19.6	19.2	24.6	120.0	5.3	6.0
BMF.TM.100.XAV	22.5	22.0	31.1	120.0	7.9	10.0
BMF.4M.100.XAV	25.0	24.5	31.1	120.0	7.9	10.0
BMF.LM.100.XAV	28.5	28.0	31.1	150.0	7.9	10.0
BMF.5M.100.XAV	34.0	33.5	31.1	150.0	7.9	10.0

**Note:** this cap is suitable for use with any alignment key configuration.

### BGF Blanking caps for plugs

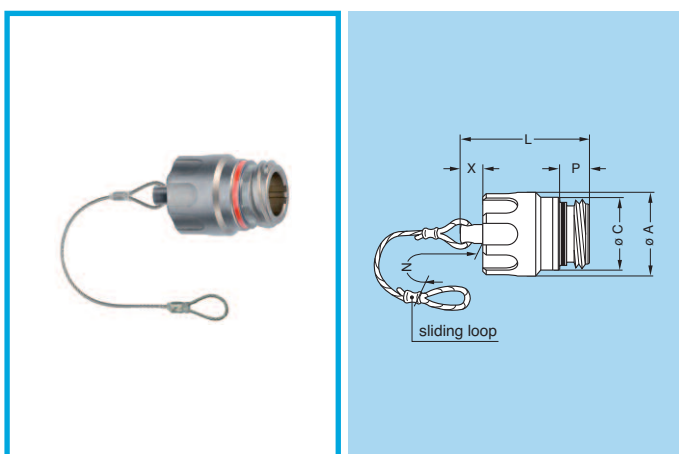

Part number	Dimensions (mm)					
	A	C	L	N	P	X
BGF.0M.100.XAV	14.4	12.7	24.6	85.0	5.3	6.0
BGF.1M.100.XAV	15.9	14.2	24.6	85.0	5.3	6.0
BGF.2M.100.XAV	18.9	17.2	24.6	85.0	5.3	6.0
BGF.3M.100.XAV	20.9	19.2	24.6	120.0	5.3	6.0
BGF.TM.100.XAV	23.4	22.0	31.1	120.0	7.9	10.0
BGF.4M.100.XAV	25.9	24.5	31.1	120.0	7.9	10.0
BGF.LM.100.XAV	29.4	28.0	31.1	150.0	7.9	10.0
BGF.5M.100.XAV	34.9	33.5	31.1	150.0	7.9	10.0

**Note:** this cap is suitable for use with any alignment key configuration.

### BME Blanking caps for fixed sockets

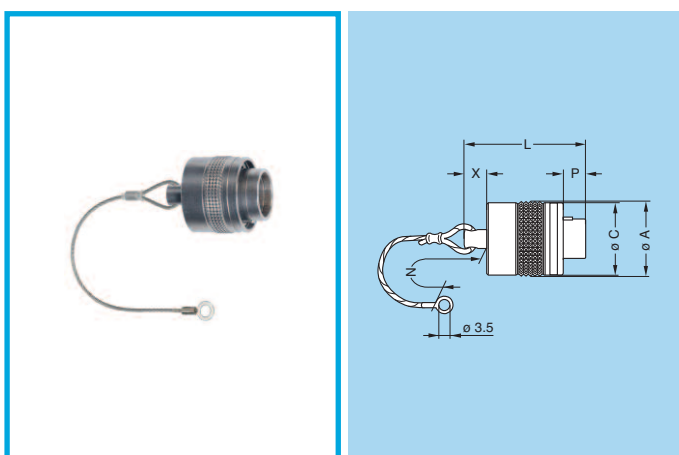

Part number	Dimensions (mm)					
	A	C	L	N	P	X
BME.0M.200.XAZ	13.1	12.7	23.4	85.0	3.9	6.0
BME.1M.200.XAZ	14.6	14.2	23.4	85.0	3.9	6.0
BME.2M.200.XAZ	17.6	17.2	23.4	85.0	3.9	6.0
BME.3M.200.XAZ	19.6	19.2	23.4	120.0	3.9	6.0
BME.TM.200.XAZ	22.5	22.0	31.0	120.0	3.4	10.0
BME.4M.200.XAZ	25.0	24.5	31.0	120.0	3.4	10.0
BME.LM.200.XAZ	28.5	28.0	31.0	150.0	3.4	10.0
BME.5M.200.XAZ	34.0	33.5	31.0	150.0	3.4	10.0

**Note:** this cap is suitable for use with any alignment key configuration.

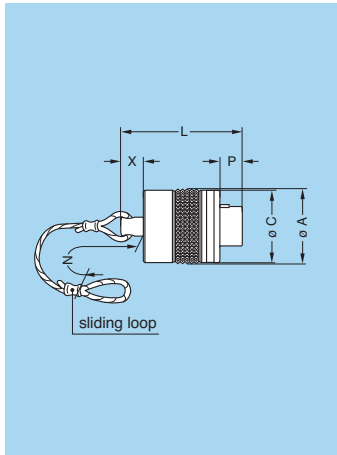

### BMF Blanking caps for free sockets

Part number	Dimensions (mm)					
	A	C	L	N	P	X
BMF.0M.200.XAZ	13.1	12.7	23.4	85.0	3.9	6.0
BMF.1M.200.XAZ	14.6	14.2	23.4	85.0	3.9	6.0
BMF.2M.200.XAZ	17.6	17.2	23.4	85.0	3.9	6.0
BMF.3M.200.XAZ	19.6	19.2	23.4	120.0	3.9	6.0
BMF.TM.200.XAZ	22.5	22.0	31.0	120.0	3.4	10.0
BMF.4M.200.XAZ	25.0	24.5	31.0	120.0	3.4	10.0
BMF.LM.200.XAZ	28.5	28.0	31.0	150.0	3.4	10.0
BMF.5M.200.XAZ	34.0	33.5	31.0	150.0	3.4	10.0

**Note:** this cap is suitable for use with any alignment key configuration.

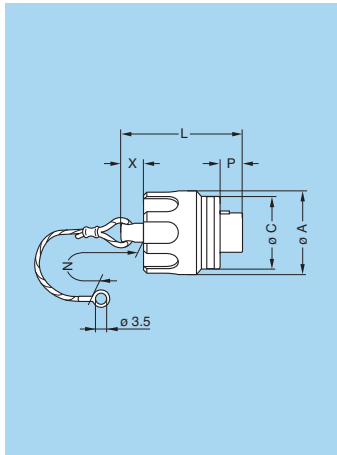

### BGE Blanking caps for fixed sockets

Part number	Dimensions (mm)					
	A	C	L	N	P	X
BGE.0M.200.XAZ	14.4	12.7	23.4	85.0	3.9	6.0
BGE.1M.200.XAZ	15.9	14.2	23.4	85.0	3.9	6.0
BGE.2M.200.XAZ	18.9	17.2	23.4	85.0	3.9	6.0
BGE.3M.200.XAZ	20.9	19.2	23.4	120.0	3.9	6.0
BGE.TM.200.XAZ	23.4	22.0	31.0	120.0	3.4	10.0
BGE.4M.200.XAZ	25.9	24.5	31.0	120.0	3.4	10.0
BGE.LM.200.XAZ	29.4	28.0	31.0	150.0	3.4	10.0
BGE.5M.200.XAZ	34.9	33.5	31.0	150.0	3.4	10.0

**Note:** this cap is suitable for use with any alignment key configuration.

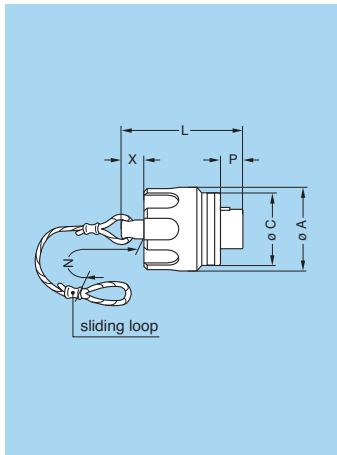

### BGF Blanking caps for free sockets

Part number	Dimensions (mm)					
	A	C	L	N	P	X
BGF.0M.200.XAZ	14.4	12.7	23.4	85.0	3.9	6.0
BGF.1M.200.XAZ	15.9	14.2	23.4	85.0	3.9	6.0
BGF.2M.200.XAZ	18.9	17.2	23.4	85.0	3.9	6.0
BGF.3M.200.XAZ	20.9	19.2	23.4	120.0	3.9	6.0
BGF.TM.200.XAZ	23.4	22.0	31.0	120.0	3.4	10.0
BGF.4M.200.XAZ	25.9	24.5	31.0	120.0	3.4	10.0
BGF.LM.200.XAZ	29.4	28.0	31.0	150.0	3.4	10.0
BGF.5M.200.XAZ	34.9	33.5	31.0	150.0	3.4	10.0

**Note:** this cap is suitable for use with any alignment key configuration.

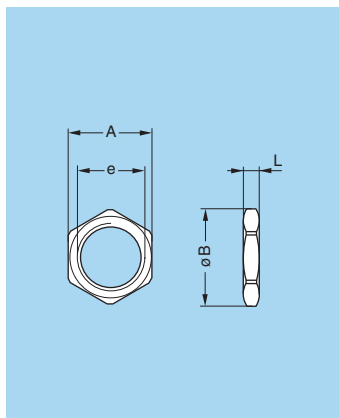

### GEA Hexagonal nuts for EC• model

Part number	Series	Dimensions (mm)			
		A	B	e	L
GEA.0M.241.RL	0M	16	18.2	M13x0.75	2.5
GEA.0E.240.RL	1M	17	19.2	M14x1.00	2.5
GEA.2M.241.RL	2M	19	21.5	M17x1.00	3.0
GEA.3M.241.RL	3M	25	22.0	M19x1.00	3.0
GEA.TM.241.RL	TM	25	28.0	M22x1.00	3.0
GEA.4M.241.RL	4M	30	34.0	M24x1.00	3.0
GEA.LM.241.RL	LM	32	36.0	M28x1.00	3.0
GEA.5M.241.RL	5M	37	41.0	M33x1.00	3.0

● Material: Nickel-plated brass (3 μm)

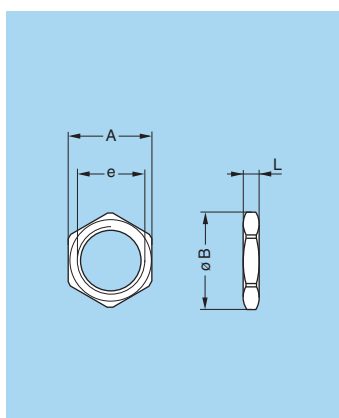

### GEA Hexagonal nuts for EG• model

Part number	Series	Dimensions (mm)			
		A	B	e	L
GEA.0S.240.RL	0M	11	12.4	M9x0.60	2.0
GEA.1M.240.RL	1M	13	14.5	M11x1.00	2.5
GEA.0E.240.RL	2M	17	19.2	M14x1.00	2.5
GEA.1E.240.RL	3M	19	21.5	M16x1.00	3.0
GEA.3S.240.RL	TM	22	25.0	M18x1.00	3.0
GEA.4M.240.RL	4M	25	28.0	M21x1.00	4.0
GEA.3S.240.RL	LM	30	34.0	M24x1.00	5.0
GEA.5M.240.RL	5M	36	40.5	M30x1.00	5.0

● Material: Nickel-plated brass (3 μm)

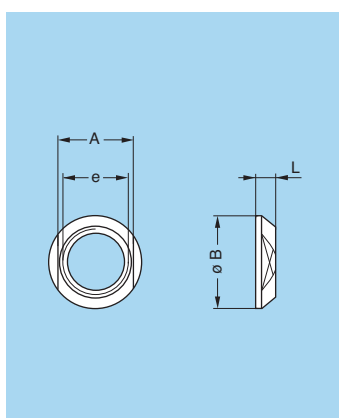

### GEC Conical nut for models HE•, EC•, PE•

Part number	Series	Dimensions (mm)			
		A	B	e	L
GEC.0M.240.RN	0M	14	17	M13x0.75	3.2
GEC.0E.240.RN	1M	16	18	M14x1.00	3.0
GEC.2M.240.RN	2M	18	21	M17x1.00	3.2
GEC.3M.240.RN	3M	20	23	M19x1.00	3.2
GEC.TM.240.RN	TM	23	27	M22x1.00	5.0
GEC.4M.240.RN	4M	25	29	M24x1.00	5.0
GEC.LM.240.RN	LM	29	33	M28x1.00	5.0
GEC.5M.240.RN	5M	34	38	M33x1.00	5.0

● Material: Anodized aluminium alloy

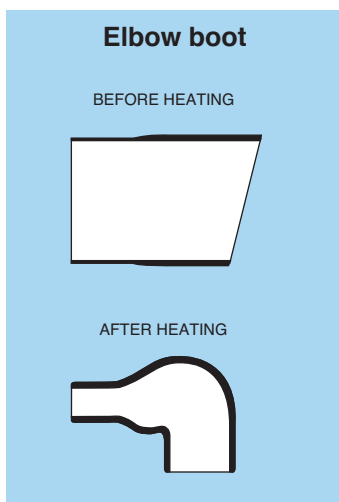
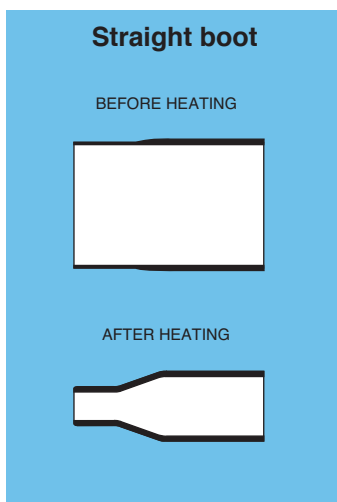

### Heatsrink boot

Supplier	Part number		Series	Cable $\phi$ min. (mm)
	Straight	Elbow 90°		
Raychem®	202A111-25/86	222A111-25/86	0M-2M	3.8
	202A121-25/86	222A121-25/86	2M-4M	5.3
	202A142-25/86	222A142-25/86	4M-5M	7.4

**Note:** request modified elastomer resistant to fluids with hot melt sealant.

## Tooling

### DCE Positioners for crimp contacts

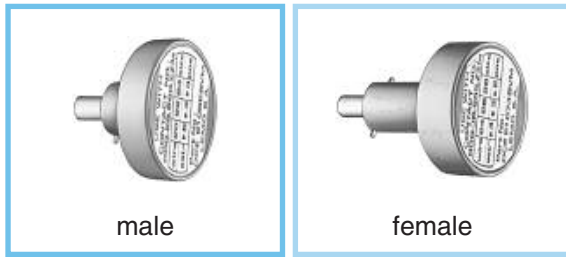

These positioners are suitable for use with both manual and pneumatic crimping tools according to the MIL-C-22520/7-01 standard.

Fig. 1

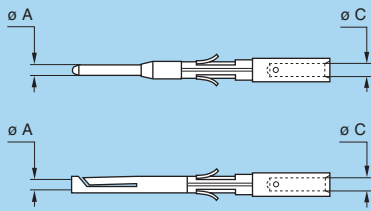
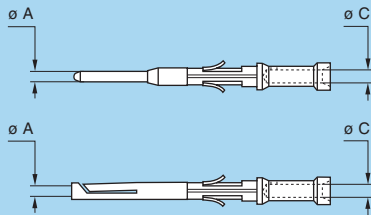
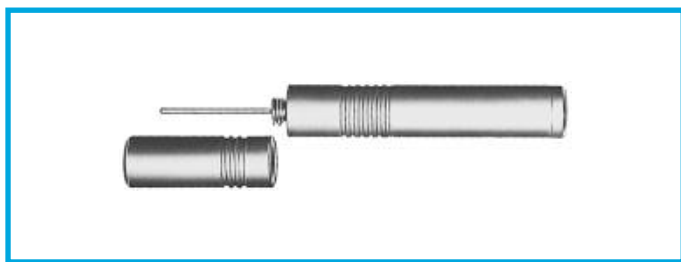

Fig. 2



	Type	Contact			Positioners part number	
		ø A (mm)	ø C (mm)	Form per fig.	For male contacts	For female contacts
<b>0M</b>	302-303	0.9	1.10	1	DCE.91.090.5MVC	DCE.91.090.3MVM
		0.9	0.87	2		
	304-305	0.7	0.87	1	DCE.91.070.5MVC	DCE.91.070.3MVM
0.7		0.44	2			
<b>1M</b>	305	0.9	1.10	1	DCE.91.090.5MVC	DCE.91.090.3MVM
		0.9	0.87	2		
	307-308	0.7	0.87	1	DCE.91.070.5MVC	DCE.91.070.3MVM
0.7		0.44	2			
<b>2M</b>	308-310	0.9	1.10	1	DCE.91.090.5MVC	DCE.91.090.3MVM
		0.9	0.87	2		
	312-319	0.7	0.87	1	DCE.91.070.5MVC	DCE.91.070.3MVM
0.7		0.44	2			
<b>3M</b>	322-330	0.7	0.87	1	DCE.91.070.5MVC	DCE.91.070.3MVM
		0.7	0.44	2		
<b>TM</b>	325	0.9	1.10	1	DCE.91.090.5MVC	DCE.91.09T.5MVM
		0.9	0.87	2		
	340	0.7	0.87	1	DCE.91.070.5MVC	DCE.91.07T.5MVM
0.7		0.44	2			
<b>4M</b>	340-348	0.7	0.87	1	DCE.91.070.5MVC	DCE.91.07T.5MVM
		0.7	0.44	2		
<b>LM</b>	355	0.9	1.10	1	DCE.91.090.5MVC	DCE.91.09T.5MVM
		0.9	0.87	2		
	368	0.7	0.87	1	DCE.91.070.5MVC	DCE.91.07T.5MVM
0.7		0.44	2			
<b>5M</b>	366	0.9	1.10	1	DCE.91.090.5MVC	DCE.91.09T.5MVM
		0.9	0.87	2		
	114	0.7	0.87	1	DCE.91.070.5MVC	DCE.91.07T.5MVM
		0.7	0.44	2		

**Note:** a wide variation of strand number and diameter combinations are quoted as being AWG, some of which do not have a large enough cross section to guarantee a crimp as per either MIL-C-22520/1-01 or /7-01. Our technical department is at your disposal to study and propose a solution to all your applications.



### DCF Extractors for crimp contacts

Contact ø	Part number
0.9	DCF.93.090.4LT
0.7	DCF.93.070.4LT

**Note:** this model is used for male and female contacts.



# Panel Cut-out

## Panel cut-outs

EG●-EC●-HE●-PE●

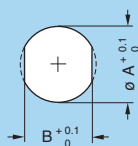

ED●-PV●-PF●

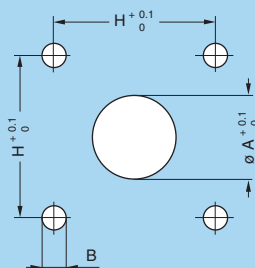

PB●

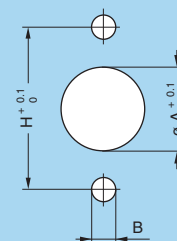

## Cut-outs

Series	EG●		EC●		HE●		PE●		ED●			PB●			PV●			PF●		
	$\varnothing A$	B	$\varnothing A$	B	$\varnothing A$	B	$\varnothing A$	B	$\varnothing A$	B	H	$\varnothing A$	B	H	$\varnothing A$	B	H	$\varnothing A$	B	H
0M	9.1	8.3	13.1	11.6	13.1	11.6	13.1	11.6	5.1	M2.5	11.0	14.8	M3.0	21.4	14.8	M2.5	15.1	10.8	M2.5	11.0
1M	11.1	9.6	14.1	12.6	14.1	12.6	14.1	12.6	6.1	M3.0	12.9	16.8	M3.0	23.4	16.8	M3.0	18.3	12.5	M3.0	12.9
2M	14.1	12.6	17.1	15.6	17.1	15.6	17.1	15.6	9.1	M3.0	15.1	19.8	M3.0	26.4	19.8	M3.0	20.6	15.6	M3.0	15.1
3M	16.1	14.6	19.1	17.6	19.1	17.6	19.1	17.6	11.1	M3.0	16.4	21.8	M3.0	29.0	21.8	M3.0	23.0	18.1	M3.0	16.6
TM	18.1	16.6	22.1	20.6	22.1	20.6	22.1	20.6	12.5	M3.0	18.3	24.8	M3.0	32.5	24.8	M3.0	24.6	19.9	M3.0	18.3
4M	21.1	19.6	24.1	22.6	24.1	22.6	24.1	22.6	14.1	M3.0	20.6	27.8	M3.0	35.0	27.8	M3.0	27.0	22.7	M3.0	20.6
LM	24.1	22.6	28.1	26.6	28.1	26.6	28.1	26.6	18.1	M3.0	23.0	30.8	M3.0	38.0	30.8	M3.0	25.4	25.9	M3.0	23.0
5M	30.1	28.6	33.1	31.6	33.1	31.6	33.1	31.6	23.2	M3.0	27.0	37.8	M3.0	45.0	37.8	M3.0	34.9	33.1	M3.0	29.4

## Mounting nut torque (on panel)

Series	Torque (Nm)
0M	1.0
1M	1.5
2M	2.0
3M	2.5

Series	Torque (Nm)
TM	4.0
4M	5.0
LM	6.5
5M	8.0

## PCB drilling pattern

### Fixed socket with straight print contact (HE●)

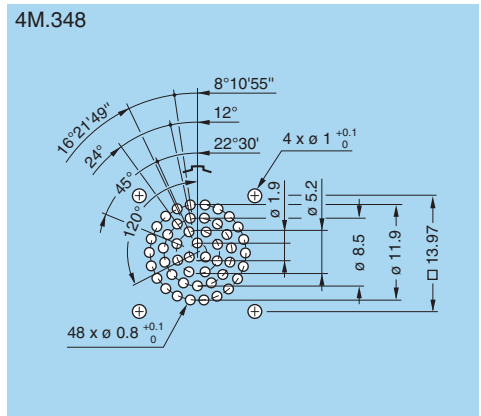
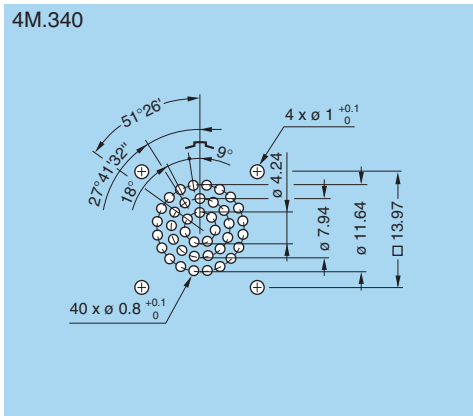
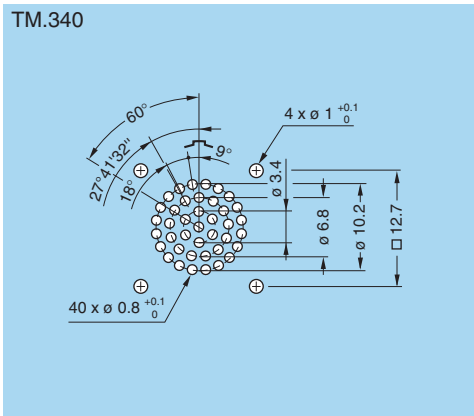
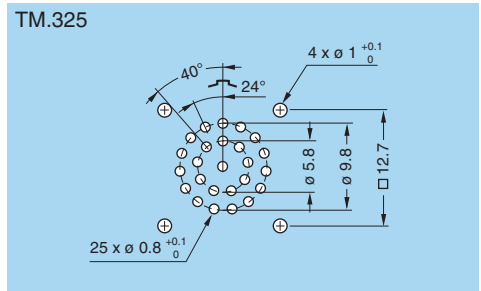
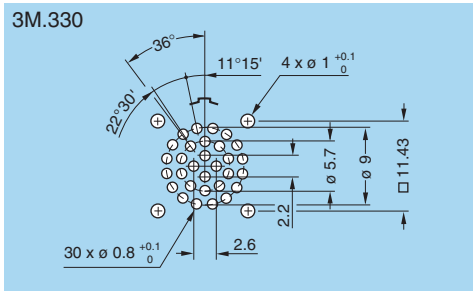
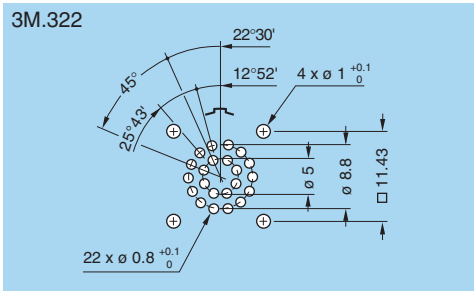
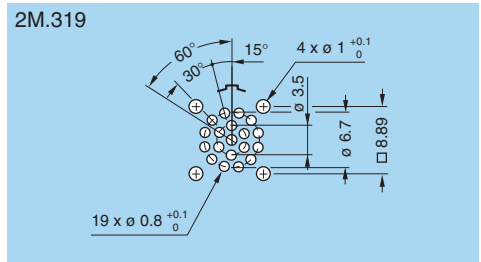
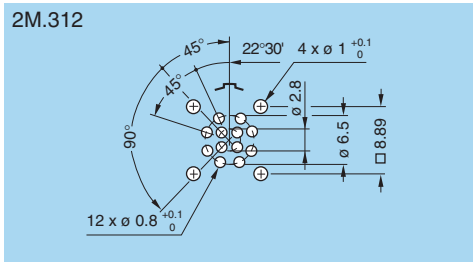
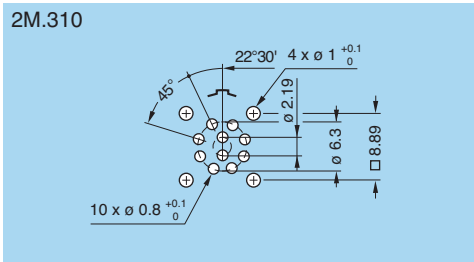
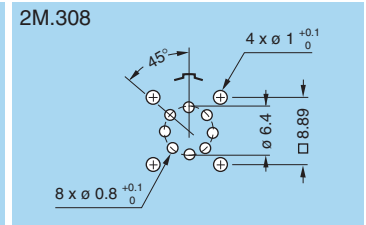
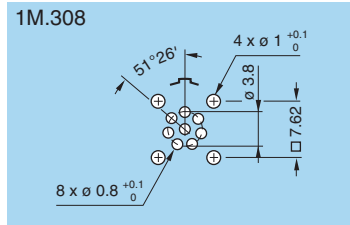
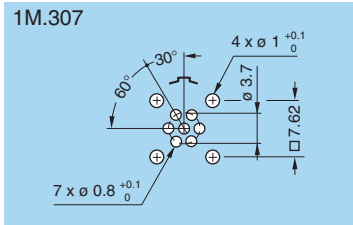
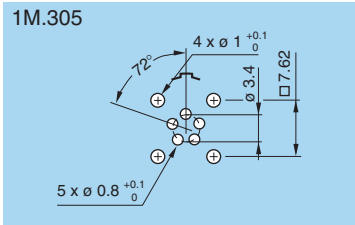
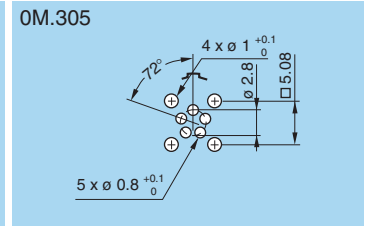
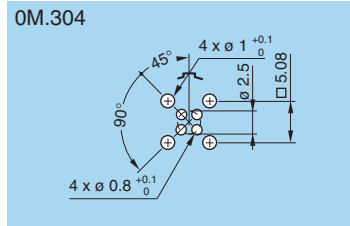
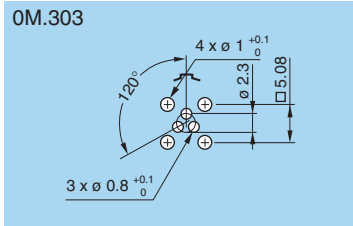
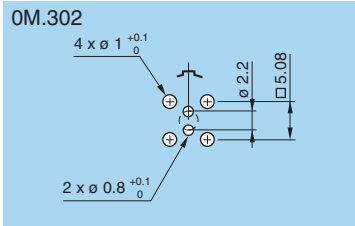

LM.355

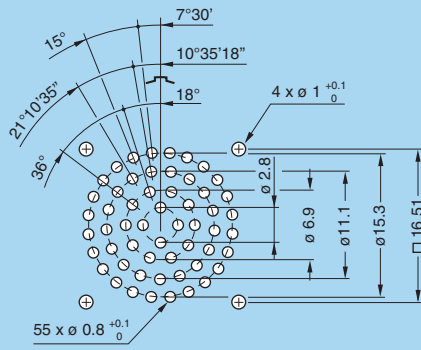

LM.368

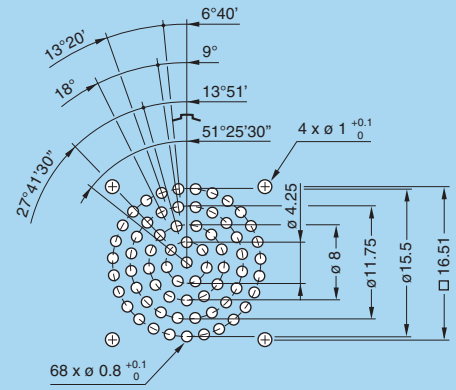

5M.366

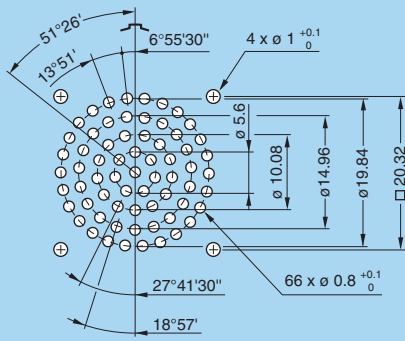

5M.114

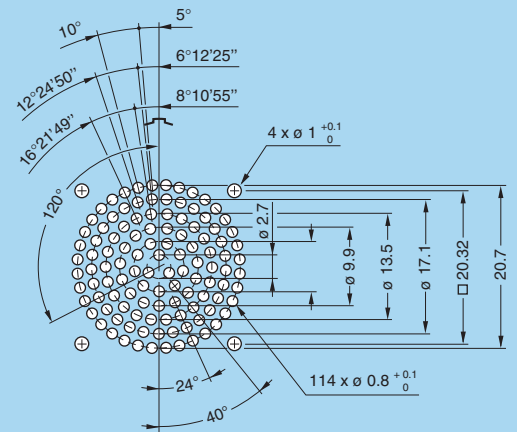

## Assembly instructions for plugs and sockets

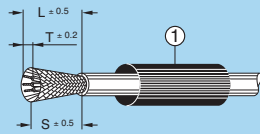
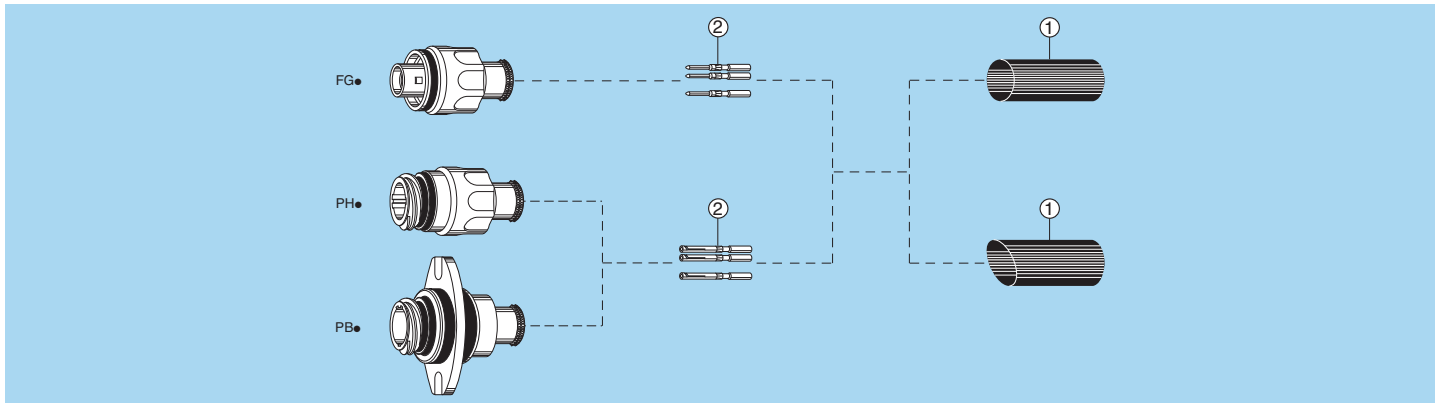

### 1. Cable preparation

First place the heatshrink boot ① over the cable. Strip the cable according to dimensions of the table, then widen the shield.

Series	L	S	T
0M to 5M	20	15	3.5

Note: dimensions are in mm.

### 2. Cable termination

**2.1** With shielded cables, widen and pull the shield all the way to the back. Fix the appropriate positioner onto the crimping tool and set the selector to the number corresponding to the AWG of the conductor used as indicated on the positioner label.

Fit the conductor into the contact ②; make sure it is visible through the contact's inspection hole.

Slide the conductor-contact assembly into the open crimping tool; make sure that the contact is pushed fully into the positioner. Close the tool. Remove from crimping tool and check that conductor is secure in contact and shows in inspection hole.

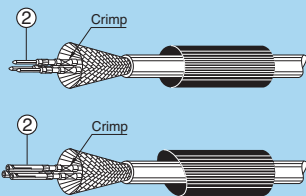

**2.2** Arrange the conductor-contact assemblies according to the markings, into the rear cable seal.

Push them deeply into the insulator, using tweezers if necessary; check that all the contacts are correctly located in the insulator: 1) by verifying the alignment of the contacts at the front of the insulator and 2) by gently pulling on each conductor.

Verification should also be made using the appropriate retention testing tool.

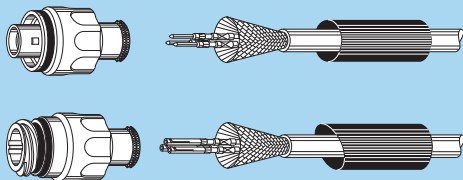

**2.3** Bring the shield around the rear of connector.

Secure it with a band-it tie-wrap (not furnished) to fix the shield in place. Cut off the possible shield surplus.

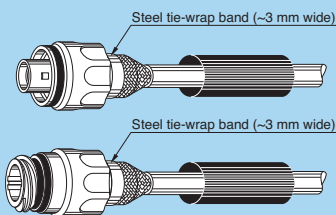

**2.4** Put the heatshrink boot in place and heat gently until it retracts.

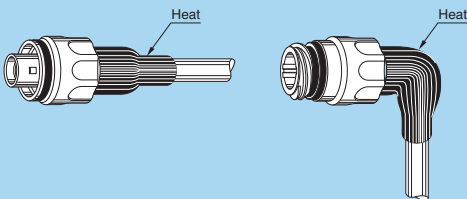

## Assembly instructions for plugs and sockets (with optional mold stop)

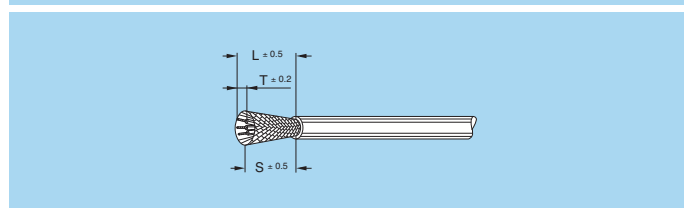
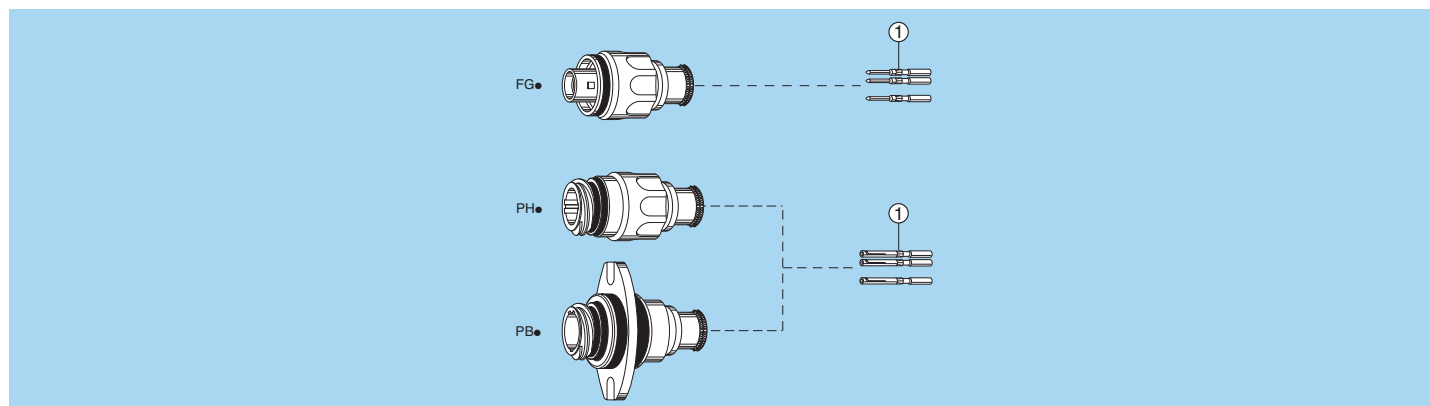

### 1. Cable preparation

Strip the cable according to dimensions of the table, then widen the shield.

Series	L	S	T
OM to 5M	20	15	3.5

Note: dimensions are in mm.

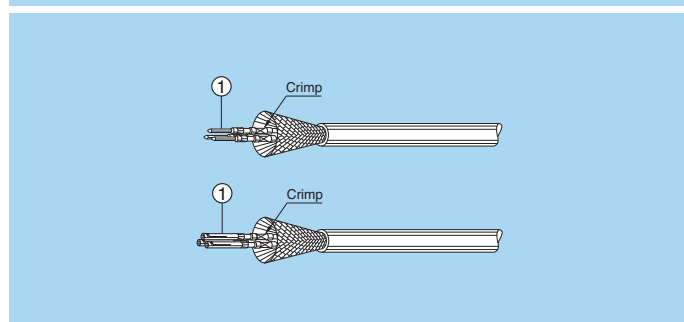

### 2. Cable termination

**2.1** With shielded cables, widen and pull the shield all the way to the back. Fix the appropriate positioner onto the crimping tool and set the selector to the number corresponding to the AWG of the conductor used as indicated on the positioner label.

Fit the conductor into the contact ①; make sure it is visible through the contact's inspection hole.

Slide the conductor-contact assembly into the open crimping tool; make sure that the contact is pushed fully into the positioner. Close the tool. Remove from crimping tool and check that conductor is secure in contact and shows in inspection hole.

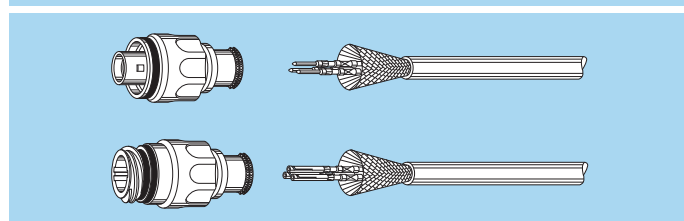

**2.2** Arrange the conductor-contact assemblies according to the markings, into the rear cable seal.

Push them deeply into the insulator, using tweezers if necessary; check that all the contacts are correctly located in the insulator: 1) by verifying the alignment of the contacts at the front of the insulator and 2) by gently pulling on each conductor.

Verification should also be made using the appropriate retention testing tool.

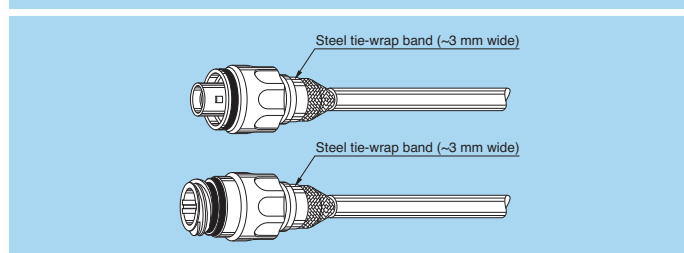

**2.3** Bring the shield around the rear of connector until the mold stop.

Secure it with a band-it tie-wrap (not furnished) to fix the shield in place. Cut off the possible shield surplus.

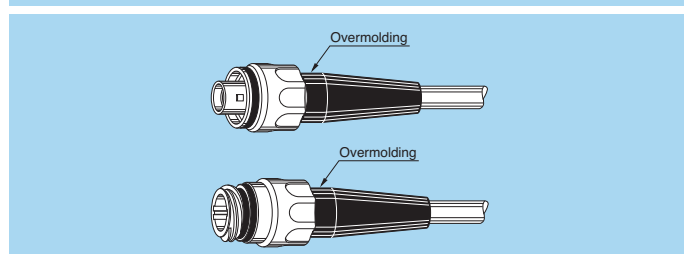

**2.4** Custom overmold cable assembly.

## Notes

## Product safety notice

**PLEASE READ AND FOLLOW ALL INSTRUCTIONS CAREFULLY AND CONSULT ALL RELEVANT NATIONAL AND INTERNATIONAL SAFETY REGULATIONS FOR YOUR APPLICATION. IMPROPER HANDLING, CABLE ASSEMBLY, OR WRONG USE OF CONNECTORS CAN RESULT IN HAZARDOUS SITUATIONS.**

### 1. SHOCK AND FIRE HAZARD

Incorrect wiring, the use of damaged components, presence of foreign objects (such as metal debris), and / or residue (such as cleaning fluids), can result in short circuits, overheating, and / or risk of electric shock. Mated components should never be disconnected while live as this may result in an exposed electric arc and local overheating, resulting in possible damage to components.

### 2. HANDLING

Connectors and their components should be visually inspected for damage prior to installation and assembly. Suspect components should be rejected or returned to the factory for verification. Connector assembly and installation should only be carried out by properly trained personnel. Proper tools must be used during installation and / or assembly in order to obtain safe and reliable performance.

### 3. USE

Connectors with exposed contacts should never be live (or on the current supply side of a circuit). Under general conditions voltages above 30 VAC and 42 VDC are considered hazardous and proper measures should be taken to eliminate all risk of transmission of such voltages to any exposed metal part of the connector.

### 4. TEST AND OPERATING VOLTAGES

The maximum admissible operating voltage depends upon the national or international standards in force for the application in question. Air and creepage distances impact the operating voltage; reference values are indicated in the catalog however these may be influenced by PC board design and / or wiring harnesses. The test voltage indicated in the catalog is 75% of the mean breakdown voltage; the test is applied at 500 V/s and the test duration is 1 minute.

### 5. CE MARKING

CE marking  means that the appliance or equipment bearing it complies with the protection requirements of one or several European safety directives.

CE marking  applies to complete products or equipment, **but not to electromechanical components, such as connectors.**

### 6. PRODUCT IMPROVEMENTS

The LEMO Group reserves the right to modify and improve to our products or specifications without providing prior notification.

Data subject to change

No reproduction or use without express permission of editorial or pictorial content, in any manner.  
LEMO reserve the right at all times to modify and improve specifications without any notification.

## LEMO HEADQUARTERS

### SWITZERLAND

#### LEMO SA

Chemin des Champs-Courbes 28 - P.O. Box 194 - CH-1024 Ecublens  
Tel. (+41 21) 695 16 00 - Fax (+41 21) 695 16 02 - e-mail: info@lemo.com

## LEMO SUBSIDIARIES

### AUSTRIA

#### LEMO Elektronik GesmbH

Lemböckgasse 49/E6-3  
1230 Wien  
Tel: (+43 1) 914 23 20 0  
Fax: (+43 1) 914 23 20 11  
sales@lemo.at

### CHINA

#### LEMO Trading (Shanghai) Co., Ltd

#### LEMO Electronics (Shanghai) Co., Ltd

5th Floor, Block 6, City of ELITE,  
1000 Jinhai Road, Pudong  
Shanghai, China 201206  
Tel: (+86 21) 5899 7721  
Fax: (+86 21) 5899 7727  
cn.sales@lemo.com

### DENMARK

#### LEMO Denmark A/S

Gammel Mosevej 46  
2820 Gentofte  
Tel: (+45) 45 20 44 00  
Fax: (+45) 45 20 44 01  
info-dk@lemo.com

### FRANCE

#### LEMO France Sàrl

24/28 Avenue Graham Bell  
Bâtiment Balthus 4  
Bussy Saint Georges  
77607 Marne la Vallée Cedex 3  
Tel: (+33 1) 60 94 60 94  
Fax: (+33 1) 60 94 60 90  
info-fr@lemo.com

### GERMANY

#### LEMO Elektronik GmbH

Hanns-Schwindt-Str. 6  
81829 München  
Tel: (+49 89) 42 77 03  
Fax: (+49 89) 420 21 92  
info@lemo.de

### HONG KONG

#### LEMO Hong Kong Ltd

Unit 1207, 12/F, Corporation Square,  
8 Lam Lok Street, Kowloon Bay,  
Kowloon - Hong Kong  
Tel: (+852) 2174 0468  
Fax: (+852) 2174 0492  
hk.sales@lemo.com

### HUNGARY

#### REDEL Elektronika Kft

Nagysándor József u. 6-12  
1201 Budapest  
Tel: (+36 1) 421 47 10  
Fax: (+36 1) 421 47 57  
redelemo@lemo.hu

### ITALY

#### LEMO Italia srl

Viale Lunigiana 25  
20125 Milano  
Tel: (+39 02) 66 71 10 46  
Fax: (+39 02) 66 71 10 66  
sales.it@lemo.com

### JAPAN

#### LEMO Japan Ltd

4-10-3, Takaido Higashi,  
Suginami-ku, Tokyo, 168-0072  
Tel: (+81 3) 53 44 39 33  
Fax: (+81 3) 53 44 39 35  
lemoinfo@lemo.co.jp

### NETHERLANDS / BELGIUM

#### LEMO Connectors Benelux

De Trompet 2108  
1967 DC Heemskerk  
Tel: (+31) 251 25 78 20  
Fax (+31) 251 25 78 21  
info@lemo.nl

### NORWAY / ICELAND

#### LEMO Norway A/S

Stanseveien 6B  
0975 Oslo  
Tel: (+47) 22 91 70 40  
Fax: (+47) 22 91 70 41  
info-no@lemo.com

### SINGAPORE

#### LEMO Asia Pte Ltd

4 Leng Kee Road,  
#06-09 SiS Building  
Singapore 159088  
Tel: (+65) 6476 0672  
Fax: (+65) 6474 0672  
sg.sales@lemo.com

### SPAIN / PORTUGAL

#### IBERLEMO S.A.

Brasil, 45, 08402 Granollers  
Barcelona  
Tel: (+34 93) 860 44 20  
Fax: (+34 93) 879 10 77  
info-es@lemo.com

#### Madrid Office

Antonio López, 96, 28019 Madrid  
Tel: (+34 91) 469 99 19  
Fax: (+34 91) 469 99 59

### SWEDEN / FINLAND

#### LEMO Nordic AB

Mariehällsvägen 39A  
168 65 Bromma  
Tel: (+46 8) 635 60 60  
Fax: (+46 8) 635 60 61  
info-se@lemo.com

### SWITZERLAND

#### LEMO Verkauf AG

Grundstrasse 22 B  
6343 Rotkreuz  
Tel: (+41 41) 790 49 40  
Fax: (+41 41) 790 49 43  
ch.sales@lemo.com

### UNITED KINGDOM

#### LEMO UK Ltd

12-20 North Street  
Worthing  
West Sussex, BN11 1DU  
Tel: (+44 1903) 23 45 43  
Fax: (+44 1903) 20 62 31  
lemouk@lemo.com

### USA

#### LEMO USA Inc

P.O. Box 2408  
Rohnert Park, CA 94927-2408  
Tel: (+1 707) 578 88 11  
(+1 800) 444 53 66  
Fax: (+1 707) 578 08 69  
info@lemousa.com

## LEMO DISTRIBUTORS

AUSTRALIA, BRAZIL, CANADA, CZECH REPUBLIC, GREECE, INDIA, ISRAEL,  
NEW ZEALAND, PAKISTAN, POLAND, RUSSIA, SOUTH AFRICA, SOUTH KOREA,  
TAIWAN, TURKEY, UKRAINE

www.lemo.com





Компания «Океан Электроники» предлагает заключение долгосрочных отношений при поставках импортных электронных компонентов на взаимовыгодных условиях!

Наши преимущества:

- Поставка оригинальных импортных электронных компонентов напрямую с производств Америки, Европы и Азии, а так же с крупнейших складов мира;
- Широкая линейка поставок активных и пассивных импортных электронных компонентов (более 30 млн. наименований);
- Поставка сложных, дефицитных, либо снятых с производства позиций;
- Оперативные сроки поставки под заказ (от 5 рабочих дней);
- Экспресс доставка в любую точку России;
- Помощь Конструкторского Отдела и консультации квалифицированных инженеров;
- Техническая поддержка проекта, помощь в подборе аналогов, поставка прототипов;
- Поставка электронных компонентов под контролем ВП;
- Система менеджмента качества сертифицирована по Международному стандарту ISO 9001;
- При необходимости вся продукция военного и аэрокосмического назначения проходит испытания и сертификацию в лаборатории (по согласованию с заказчиком);
- Поставка специализированных компонентов военного и аэрокосмического уровня качества (Xilinx, Altera, Analog Devices, Intersil, Interpoint, Microsemi, Actel, Aeroflex, Peregrine, VPT, Syfer, Eurofarad, Texas Instruments, MS Kennedy, Miteq, Cobham, E2V, MA-COM, Hittite, Mini-Circuits, General Dynamics и др.);

Компания «Океан Электроники» является официальным дистрибьютором и эксклюзивным представителем в России одного из крупнейших производителей разъемов военного и аэрокосмического назначения «JONHON», а так же официальным дистрибьютором и эксклюзивным представителем в России производителя высокотехнологичных и надежных решений для передачи СВЧ сигналов «FORSTAR».



## JONHON

«JONHON» (основан в 1970 г.)

Разъемы специального, военного и аэрокосмического назначения:

(Применяются в военной, авиационной, аэрокосмической, морской, железнодорожной, горно- и нефтедобывающей отраслях промышленности)

«FORSTAR» (основан в 1998 г.)

ВЧ соединители, коаксиальные кабели, кабельные сборки и микроволновые компоненты:

(Применяются в телекоммуникациях гражданского и специального назначения, в средствах связи, РЛС, а так же военной, авиационной и аэрокосмической отраслях промышленности).



Телефон: 8 (812) 309-75-97 (многоканальный)

Факс: 8 (812) 320-03-32

Электронная почта: [ocean@oceanchips.ru](mailto:ocean@oceanchips.ru)

Web: <http://oceanchips.ru/>

Адрес: 198099, г. Санкт-Петербург, ул. Калинина, д. 2, корп. 4, лит. А