

PLEASE CHECK WWW.MOLEX.COM FOR LATEST PART INFORMATION

Part Number: [0876391100](#)
Status: **Active**
Description: 1.27mm (.050") Pitch DDR DIMM Socket, Reverse Footprint, 25° Angle, Low Profile, Single Key, with Beveled Metal Pins and Plastic Pegs, 2.79mm (.110") Tail Length, 0.76µm (30µ") Gold (Au) Plating, 184 Circuits, Leadfree

Documents:

[3D Model](#) [Product Specification PS-87639-002 \(PDF\)](#)
[Drawing \(PDF\)](#) [RoHS Certificate of Compliance \(PDF\)](#)

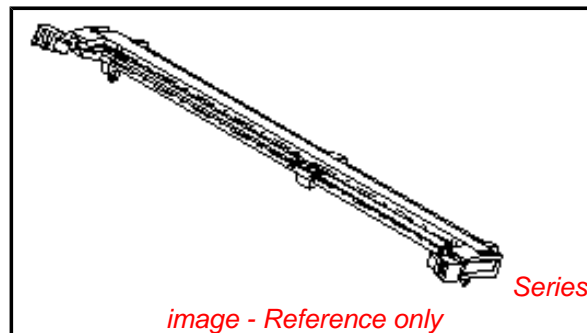

General

Product Family	Memory Module Sockets
Series	87639
Component Type	Memory Module
JEDEC Outline	MO-206
Product Name	DDR DIMM

Physical

Circuits (Loaded)	184
Color - Resin	Black, Natural
Durability (mating cycles max)	25
Entry Angle	25° Angle
Keying to Mating Part	Yes
Material - Metal	Brass, Phosphor Bronze
Material - Plating Mating	Gold
Material - Plating Termination	Tin
Material - Resin	High Temperature Thermoplastic
PC Tail Length (in)	0.110 In
PC Tail Length (mm)	2.79 mm
PCB Locator	Yes
PCB Retention	Yes
PCB Thickness Recommended (in)	0.062 In
PCB Thickness Recommended (mm)	1.60 mm
Packaging Type	Tray
Pitch - Mating Interface (in)	0.050 In
Pitch - Mating Interface (mm)	1.27 mm
Plating min: Mating (µin)	30.4
Plating min: Mating (µm)	0.76
Plating min: Termination (µin)	101.6
Plating min: Termination (µm)	2.54
Temperature Range - Operating	-40°C to +85°C
Termination Interface: Style	Through Hole

Electrical

Current - Maximum per Contact	1A
Voltage - Maximum	50V
Voltage Key	2.5V, Right

Solder Process Data

Duration at Max. Process Temperature (seconds)	10
Lead-free Process Capability	Wave Capable (TH only)
Max. Cycles at Max. Process Temperature	2
Process Temperature max. C	240

Material Info

Reference - Drawing Numbers

EU RoHS

**ELV and RoHS
Compliant**
REACH SVHC
 Not Reviewed
**Halogen-Free
Status**
 Not Reviewed

China RoHS



**Need more information on product
environmental compliance?**

Email productcompliance@molex.com
 For a multiple part number RoHS Certificate of Compliance, [click here](#)

Please visit the [Contact Us](#) section for any non-product compliance questions.

Search Parts in this Series

[87639Series](#)

Mates With

[JEDEC MO-206 modules](#)

This document was generated on 04/09/2010

PLEASE CHECK WWW.MOLEX.COM FOR LATEST PART INFORMATION

10 9 8 7 6 5 4 3 2 1

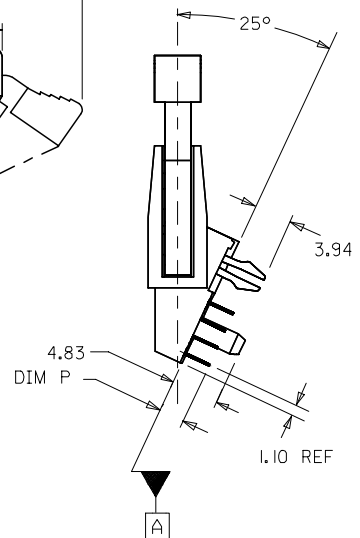
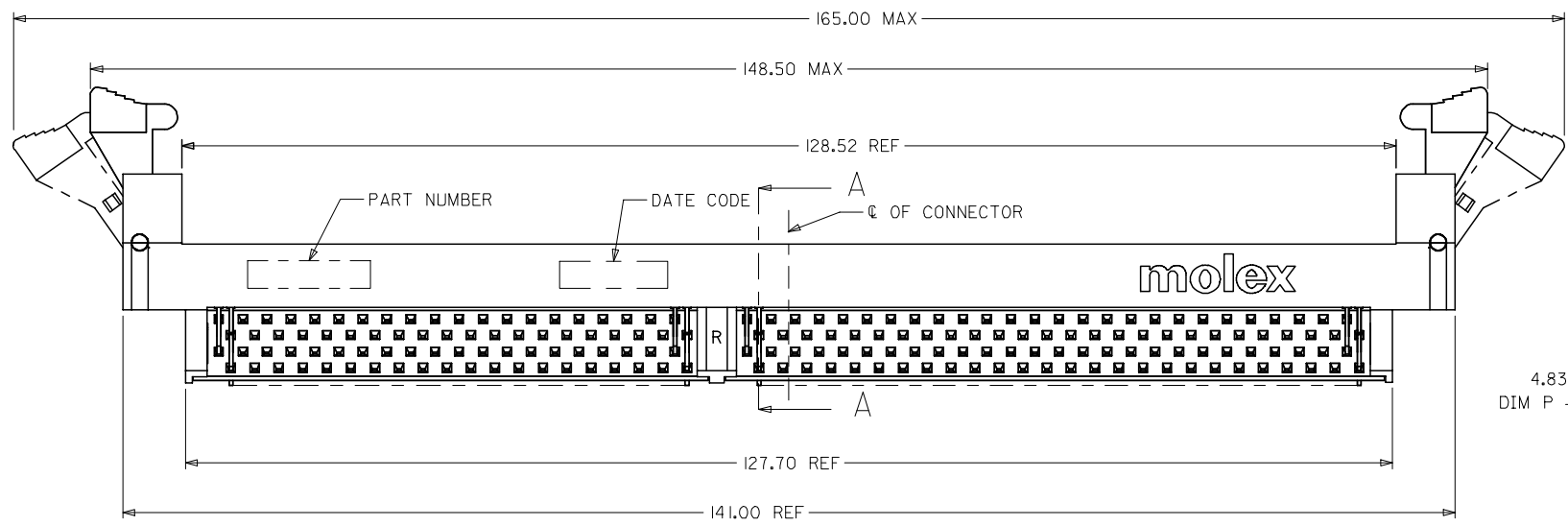
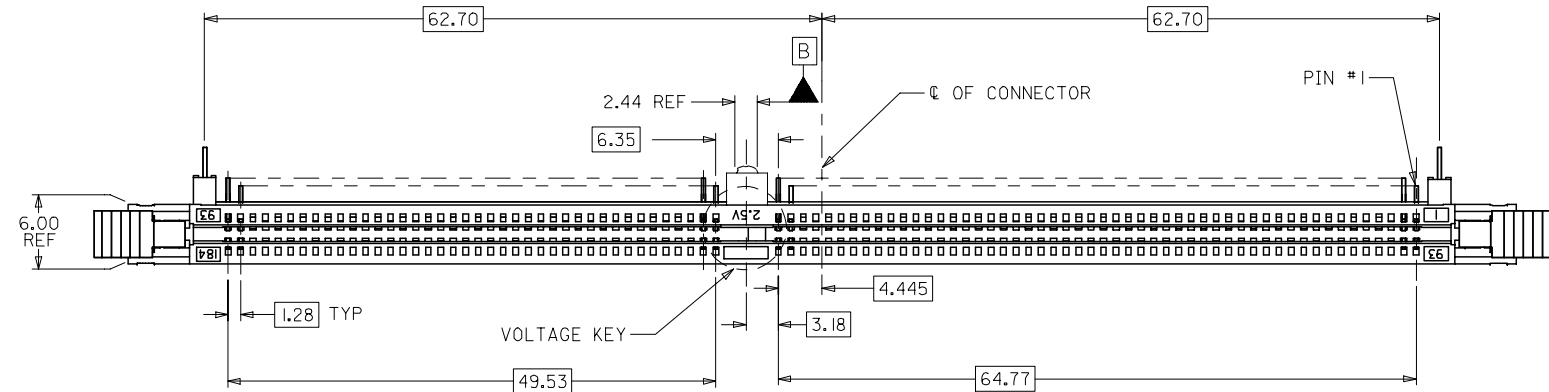

- NOTES:
- MATERIALS: HOUSING - LCP, GLASS FILLED, UL 94V-0, COLOR: BLACK
LATCHES - HIGH TEMP NYLON, GLASS FILLED, UL 94V-0
TERMINAL AND FORKLOCK - COPPER ALLOY
 - FINISHES: CONTACT AREA: SEE TABLE ON SHEET 5
SOLDDERTAILS: 2.54um/100u" MIN. TIN
OVER 1.27um/50u" MIN NICKEL
 - PRODUCT SPECIFICATIONS: PS-87639-002 FOR
PERFORMANCE SPECIFICATIONS.
 - DATE CODE SHALL BE MARKED LEGIBLY AS SHOWN: XX XX
YEAR WEEK
 - PART NUMBER SHALL BE MARKED LEGIBLY AS SHOWN: 87639-0XXX
REFER TO TABLE

OBS TIN/LEAD P/N	EC NO: S2006-0746	2006/02/27
	DRWN:HLONG	2006/02/28
	CHKD:HO	2006/02/28
	APPR:GJLEE	2006/02/28

QUALITY SYMBOLS	▽=0
	∇=0
DESCRIPTION	
REV	

GENERAL TOLERANCES (UNLESS SPECIFIED)	mm	INCH
4 PLACES	± ---	± ---
3 PLACES	± ---	± ---
2 PLACES	± 0.25	± ---
1 PLACE	± ---	± ---
ANGULAR ± 5 °		
DRAFT WHERE APPLICABLE MUST REMAIN WITHIN DIMENSIONS		

DIMENSION STYLE		SCALE	DESIGN UNITS	THIRD ANGLE PROJECTION
MM ONLY		NTS	METRIC	
DRAWN BY	DATE	TITLE		
LPLIM	2000/05/31	DDR DIMM, 1.27MM PITCH		
CHECKED BY	DATE	184 CKTS, 25 DEG REVERSE		
DSOH	2000/07/07	1.91MM ROW TO ROW		
APPROVED BY	DATE	MOLEX INCORPORATED		
SKTOH	2000/07/07			
MATERIAL NO.	DOCUMENT NO.	SHEET NO.		
SEE TABLE	SD-87639-001	1 OF 5		
SIZE	THIS DRAWING CONTAINS INFORMATION THAT IS PROPRIETARY TO MOLEX INCORPORATED AND SHOULD NOT BE USED WITHOUT WRITTEN PERMISSION			
A3				

9 8 7 6 5 4 3 2 1

10 9 8 7 6 5 4 3 2 1

F
E
D
C
B
A

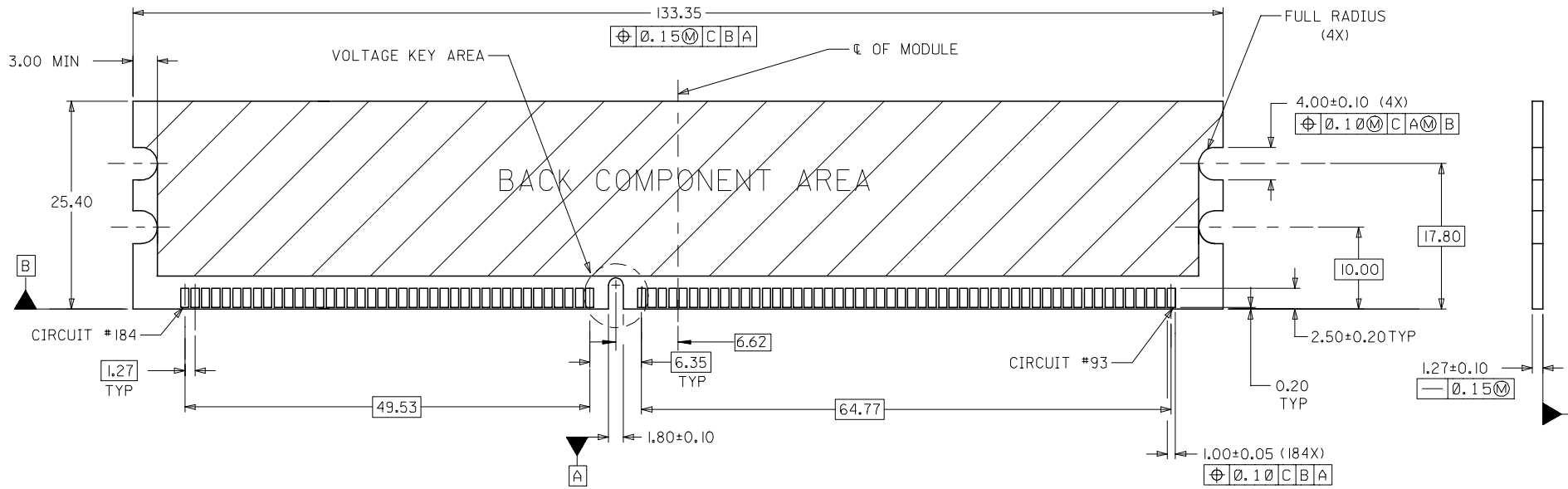

RECOMMENDED MODULE LAYOUT
(PER JEDEC STANDARD MO-206, 184 CKT.)
UNLESS OTHERWISE SPECIFIED, GENERAL TOLERANCE FOR MODULE = ±0.13

VOLTAGE KEY AREA

VOLTAGE KEY	DIM 'A'
2.5V	4.175

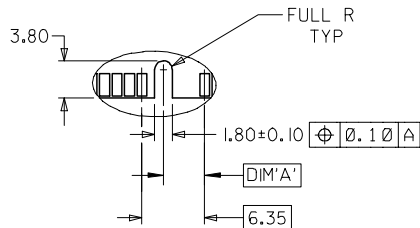

OBS	TIN/LEAD P/N
EC NO:	S2006-0746
DRWN:	MLONG
CHKD:	IHO
APPR:	GGLEE
REV	DESCRIPTION

QUALITY SYMBOLS	▽=0
	∇=0

GENERAL TOLERANCES (UNLESS SPECIFIED)	mm	INCH	
	4 PLACES	± ---	± ---
	3 PLACES	± ---	± ---
	2 PLACES	± 0.25	± ---
	1 PLACE	± ---	± ---
	ANGULAR ± 5 °		
DRAFT WHERE APPLICABLE	MUST REMAIN WITHIN DIMENSIONS		

DIMENSION STYLE		SCALE	DESIGN UNITS	THIRD ANGLE PROJECTION
MM ONLY		NTS	METRIC	
DRAWN BY	DATE	TITLE		
LPL IM	2000/05/31	DDR DIMM, 1.27MM PITCH		
CHECKED BY	DATE	184 CKTS, 25 DEG REVERSE		
DSOH	2000/07/07	1.91MM ROW TO ROW		
APPROVED BY	DATE	MOLEX INCORPORATED		
SKTOH	2000/07/07			
MATERIAL NO.	DOCUMENT NO.	SHEET NO.		
	SD-87639-001	3 OF 5		
SIZE	THIS DRAWING CONTAINS INFORMATION THAT IS PROPRIETARY TO MOLEX INCORPORATED AND SHOULD NOT BE USED WITHOUT WRITTEN PERMISSION			
A3				

9 8 7 6 5 4 3 2 1

10 9 8 7 6 5 4 3 2 1

F

E

D

C

B

A

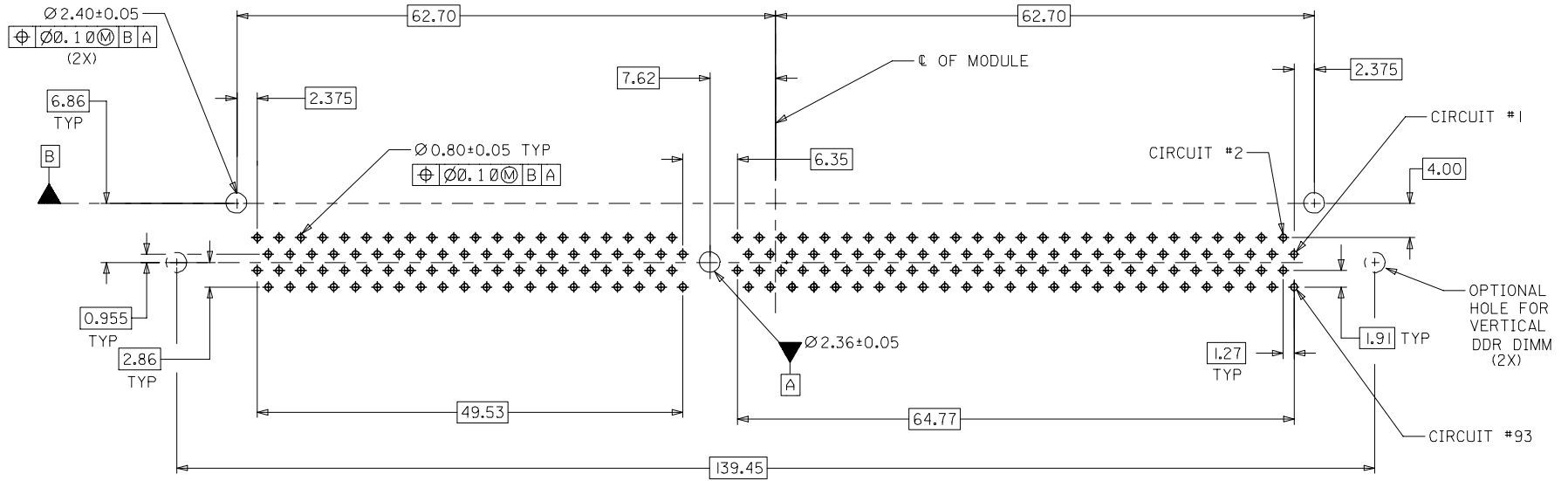

RECOMMENDED P.C. BOARD
HOLE PATTERN (CONNECTOR SIDE)

OBS TIN/LEAD P/N EC NO: S2006-0746 DRWN:MLONG CHKD:HO APPR:GJLEE	2006/02/27 2006/02/28 2006/02/28	QUALITY SYMBOLS ▽=0 ◻=0	GENERAL TOLERANCES (UNLESS SPECIFIED)		DIMENSION STYLE MM ONLY		SCALE NTS	DESIGN UNITS METRIC	THIRD ANGLE PROJECTION			
					mm	INCH	DRAWN BY LPL IM		TITLE DDR DIMM, 1.27MM PITCH 184 CKTS, 25 DEG REVERSE 1.91MM ROW TO ROW			
			4 PLACES	± ---	± ---		DATE 2000/05/31					
			3 PLACES	± ---	± ---		CHECKED BY DSOH		DATE 2000/07/07			
2 PLACES	± 0.25	± ---		APPROVED BY SKTOH		DATE 2000/07/07		MOLEX INCORPORATED				
1 PLACE	± ---	± ---	ANGULAR ± 5 °		MATERIAL NO.		DOCUMENT NO.		SHEET NO.			
DRAFT WHERE APPLICABLE MUST REMAIN WITHIN DIMENSIONS			SEE TABLE		SD-87639-001		4 OF 5					
THIS DRAWING CONTAINS INFORMATION THAT IS PROPRIETARY TO MOLEX INCORPORATED AND SHOULD NOT BE USED WITHOUT WRITTEN PERMISSION												

9 8 7 6 5 4 3 2 1

10 9 8 7 6 5 4 3 2 1

MATERIAL NO.	VOLTAGE KEY	TAIL LENGTH P±0.25	RECOMMENDED PCB THICKNESS	FINISHES: CONTACT AREA
87639-1001	RIGHT (2.5V)	2.79	1.57	SELECTIVE GOLD 0.38µM/15µ" MIN. GOLD OVER 1.27µM/50µ" MIN. NICKEL
87639-1010		3.18		
87639-1011		3.56		
87639-1100		2.79		SELECTIVE GOLD 0.76µM/30µ" MIN. GOLD OVER 1.27µM/50µ" MIN. NICKEL
87639-1110		3.18		

F

F

E

E

D

D

C

C

B

B

A

A

OBS TIN/LEAD P/N EC NO: S2006-0746 DRWN:MLONG CHKD:HO APPR:GJLEE	2006/02/27 2006/02/28 2006/02/28	DESCRIPTION REV	QUALITY SYMBOLS	GENERAL TOLERANCES (UNLESS SPECIFIED)	DIMENSION STYLE		SCALE	DESIGN UNITS	THIRD ANGLE PROJECTION
			$\nabla=0$ $\triangle=0$		mm INCH	MM ONLY	NTS	METRIC	
			4 PLACES ± --- ± --- 3 PLACES ± --- ± --- 2 PLACES ± 0.25 ± --- 1 PLACE ± --- ± ---		DRAWN BY DATE LPL IM 2000/05/31	TITLE		DDR DIMM, 1.27MM PITCH 184 CKTS, 25 DEG REVERSE 1.91MM ROW TO ROW	
			ANGULAR ± 5 °		CHECKED BY DATE DSOH 2000/07/07	MOLEX MOLEX INCORPORATED			
			DRAFT WHERE APPLICABLE MUST REMAIN WITHIN DIMENSIONS		APPROVED BY DATE SKTOH 2000/07/07	MATERIAL NO. SEE TABLE	DOCUMENT NO. SD-87639-001	SHEET NO. 5 OF 5	
SIZE A3	THIS DRAWING CONTAINS INFORMATION THAT IS PROPRIETARY TO MOLEX INCORPORATED AND SHOULD NOT BE USED WITHOUT WRITTEN PERMISSION								

9 8 7 6 5 4 3 2 1

Компания «Океан Электроники» предлагает заключение долгосрочных отношений при поставках импортных электронных компонентов на взаимовыгодных условиях!

Наши преимущества:

- Поставка оригинальных импортных электронных компонентов напрямую с производств Америки, Европы и Азии, а так же с крупнейших складов мира;
- Широкая линейка поставок активных и пассивных импортных электронных компонентов (более 30 млн. наименований);
- Поставка сложных, дефицитных, либо снятых с производства позиций;
- Оперативные сроки поставки под заказ (от 5 рабочих дней);
- Экспресс доставка в любую точку России;
- Помощь Конструкторского Отдела и консультации квалифицированных инженеров;
- Техническая поддержка проекта, помощь в подборе аналогов, поставка прототипов;
- Поставка электронных компонентов под контролем ВП;
- Система менеджмента качества сертифицирована по Международному стандарту ISO 9001;
- При необходимости вся продукция военного и аэрокосмического назначения проходит испытания и сертификацию в лаборатории (по согласованию с заказчиком);
- Поставка специализированных компонентов военного и аэрокосмического уровня качества (Xilinx, Altera, Analog Devices, Intersil, Interpoint, Microsemi, Actel, Aeroflex, Peregrine, VPT, Syfer, Eurofarad, Texas Instruments, MS Kennedy, Miteq, Cobham, E2V, MA-COM, Hittite, Mini-Circuits, General Dynamics и др.);

Компания «Океан Электроники» является официальным дистрибьютором и эксклюзивным представителем в России одного из крупнейших производителей разъемов военного и аэрокосмического назначения «JONHON», а так же официальным дистрибьютором и эксклюзивным представителем в России производителя высокотехнологичных и надежных решений для передачи СВЧ сигналов «FORSTAR».



JONHON

«JONHON» (основан в 1970 г.)

Разъемы специального, военного и аэрокосмического назначения:

(Применяются в военной, авиационной, аэрокосмической, морской, железнодорожной, горно- и нефтедобывающей отраслях промышленности)

«FORSTAR» (основан в 1998 г.)

ВЧ соединители, коаксиальные кабели, кабельные сборки и микроволновые компоненты:

(Применяются в телекоммуникациях гражданского и специального назначения, в средствах связи, РЛС, а так же военной, авиационной и аэрокосмической отраслях промышленности).



Телефон: 8 (812) 309-75-97 (многоканальный)

Факс: 8 (812) 320-03-32

Электронная почта: ocean@oceanchips.ru

Web: <http://oceanchips.ru/>

Адрес: 198099, г. Санкт-Петербург, ул. Калинина, д. 2, корп. 4, лит. А