

System Lens Drivers



μ-step System Lens Driver for Digital Still Cameras

BU24026GU

●General Description

BU24026GU is a system Lens Driver that uses μ-step driving to make the configuration of the sophisticated, high precision and low noise lens driver system possible. This IC has a built-in driver for both DC motor and voice coil motor and a μ-step controller that decreases CPU power. Therefore, multifunctional lens can be applied.

●Features

- Built-in 7 channels Driver block
1ch-6ch: Voltage control type H-bridge
7ch: Current control type H-bridge
- Built-in 2 channels PI driving circuit
- Built-in 3 channels Waveforming circuit

●Applications

- Digital still cameras

●Typical Application Circuit

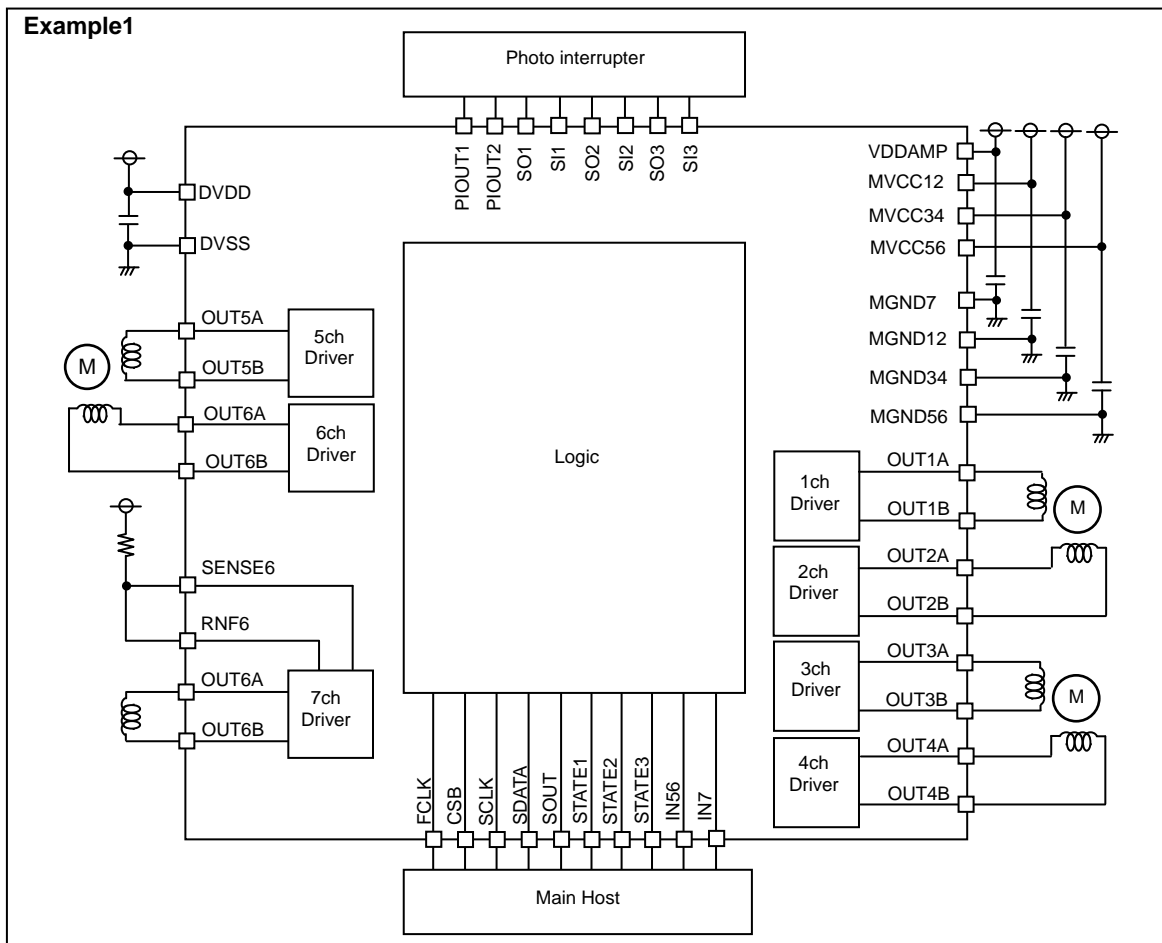

●Key Specifications

- Digital Power Supply Voltage: 2.7V to 3.6V
- Driver Power Supply Voltage: 2.7V to 5.5V
- Output Current (1ch-7ch): ±500mA(Max)
- Input Clock Frequency: 1MHz to 27.5MHz
- FET ON Resistance (1ch-6ch): 1.5Ω(Typ)
- FET ON Resistance (7ch): 0.9Ω(Typ)
- Operating Temperature Range: -20°C to +85°C

●Package

VCSP85H3

3.80mm x 3.80mm x 1.00mm

● Pin Configuration

(Bottom view)

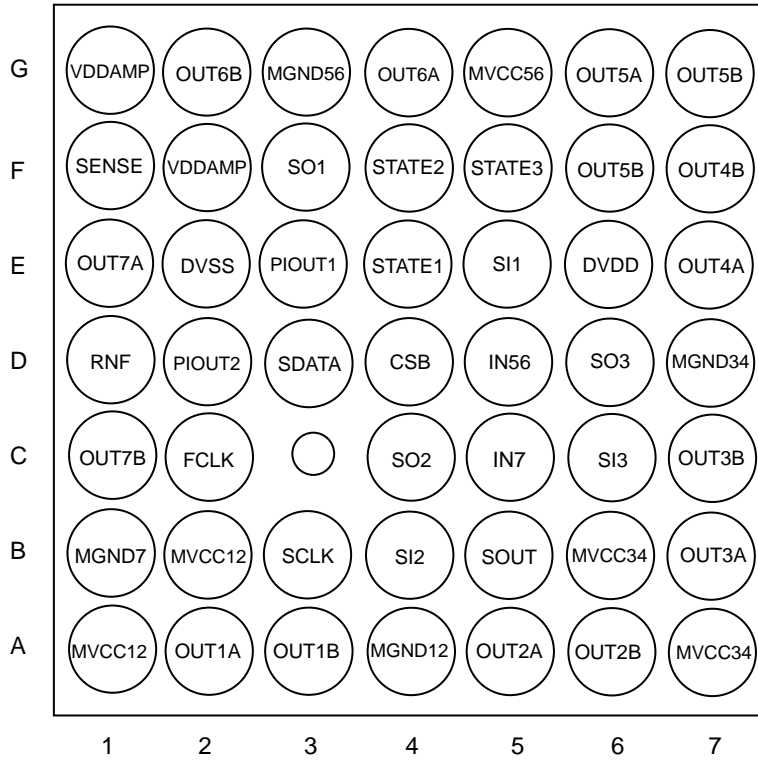

● Pin Description

Land Matrix No.	Pin Name	Power Supply	Function	Land Matrix No.	Pin Name	Power Supply	Function
E6	DVDD	-	Digital power supply	A3	OUT1B	MVCC12	1-channel driver B output
E2	DVSS	-	Ground	A5	OUT2A	MVCC12	2-channel driver A output
C2	FCLK	DVDD	main clock logic input	A6	OUT2B	MVCC12	2-channel driver B output
D4	CSB	DVDD	Serial control chip select input	A7, B6(*)	MVCC34	-	3-4channel driver power supply
B3	SCLK	DVDD	Serial control clock input	D7	MGND34	-	3-4channel driver ground
D3	SDATA	DVDD	Serial control data input	B7	OUT3A	MVCC34	3-channel driver A output
B5	SOUT	DVDD	Serial control data output	C7	OUT3B	MVCC34	3-channel driver B output
E4	STATE1	DVDD	STATE1 1ch,2ch condition logic output	E7	OUT4A	MVCC34	4-channel driver A output
F4	STATE2	DVDD	STATE2 3ch,4ch condition logic output	F7	OUT4B	MVCC34	4-channel driver B output
F5	STATE3	DVDD	STATE 3 5ch,6ch condition logic output/ 5ch,6ch control logic input	G5	MVCC56	-	5-6channel driver power supply
D5	IN56	DVDD	5ch,6ch control logic input	G3	MGND56	-	5-6channel driver ground
C5	IN7	DVDD	7ch control logic input	G6	OUT5A	MVCC56	5-channel driver A output
E3	PIOUT1	DVDD	PI driving output1	F6,G7(*)	OUT5B	MVCC56	5-channel driver B output
D2	PIOUT2	DVDD	PI driving output2	G4	OUT6A	MVCC56	6-channel driver A output
E5	SI1	DVDD	1ch waveforming input(With adjustment function of threshold voltage)	G2	OUT6B	MVCC56	6-channel driver B output
B4	SI2	DVDD	2ch waveforming input	D1	RNF	-	7-channel driver power supply
C6	SI3	DVDD	3ch waveforming input	B1	MGND7	-	7-channel driver ground
F3	SO1	DVDD	1ch waveforming output	F2,G1(*)	VDDAMP	-	Power supply of constant current driver control
C4	SO2	DVDD	2ch waveforming output	F1	SENSE	VDDAMP	Negative input for constant current driver control
D6	SO3	DVDD	3ch waveforming output	E1	OUT7A	RNF	7-channel driver A output
A1, B2(*)	MVCC12	-	1-2channel driver power supply	C1	OUT7B	RNF	7-channel driver B output
A4	MGND12	-	1-2channel driver ground	C3	INDEX	-	Index pin
A2	OUT1A	MVCC12	1-channel driver A output				

(*)It is not possible to use corner pin only. (Corner pins are A1, A7, G1, and G7.)

Please use A1-B2, A7-B6, F2-G1, F6-G7 pair respectively or using B2, B6, F2, F6 only.

● Block Diagram

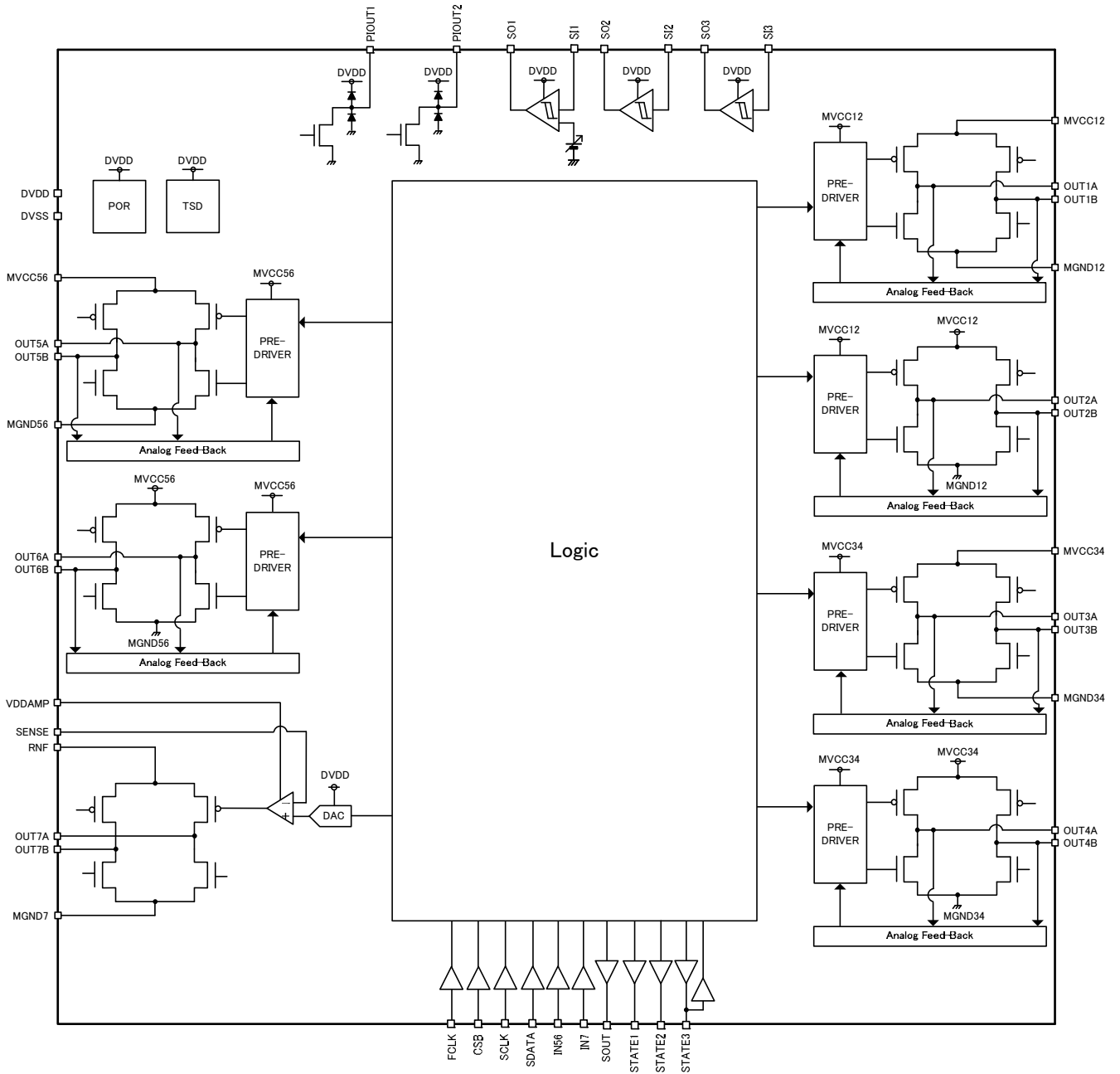

●Description of Blocks

Stepping Motor Driver (1ch-6ch Driver)

Built-in stepping motor driver of PWM driving type.
 Maximum 3 stepping motor can be driven independently.
 Built-in voltage feedback circuit of D-class type.

(1) Control

(i)Autonomous Control

The stepping motor is rotated by setting the registers for the stepping motor control.
 The state of rotation command (executing:1, finished:0), Cache register and motor position are the output from the serial output (SOUT pin). Also, the signal (MO output) which is synchronized with the motor rotation is the output from STATE pin.

It is possible to select the mode of stepping motor control from μ -step (1024 portion), 1-2 phase excitation and 2 phase excitation.

Built-in Cache registers.

Cache registers enable the setting of the subsequent process while the motor is in operation. Through these registers, operations are done continuously.

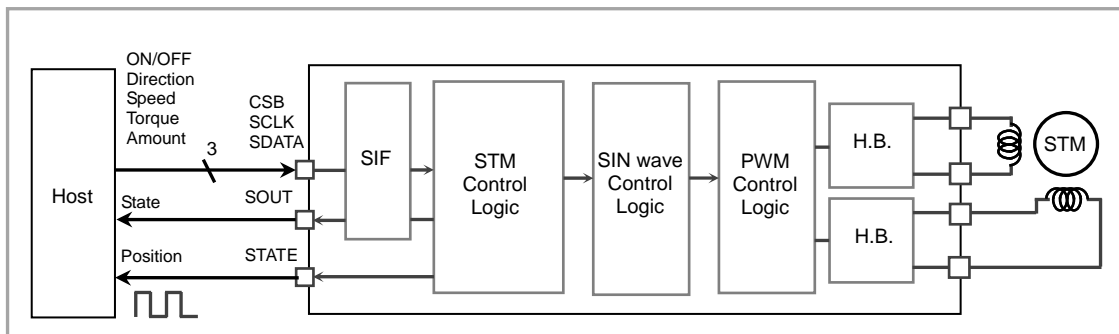

●Description of Blocks

Current Driver (7ch Driver)

Built-in constant current driver.

The voltage of RNF pin and the external resistor (RRNF) determine the amount of output current. The internal high-precision amplifier (CMOS gate input) is used for constant current control. If any resistance component exists in the wirings of RNF pin and the external resistor (RRNF), the precision can be reduced. To avoid this, pay utmost attention to the wirings.

(1) Control

(i)External Pin Control

The constant current drive is executed by the output current value and current direction which are controlled by the register setting. Constant current driving ON/OFF is controlled by IN7 pin.

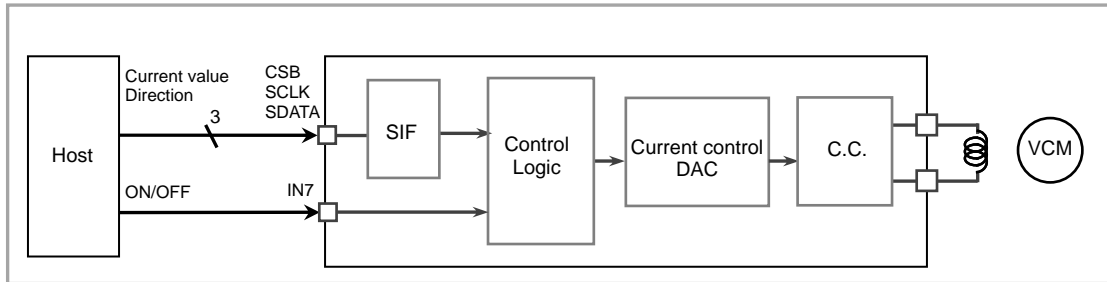

●Absolute Maximum Ratings (Ta=25°C)

Parameter	Symbol	Limit	Unit	Remark
Power Supply Voltage	DVDD	-0.3 to +4.5	V	
	MVCC	-0.3 to +7.0	V	
	VDDAMP	-0.3 to +7.0	V	
Input Voltage	VIN	-0.3 to supply voltage+0.3	V	
Input / Output Current	IIN	±500	mA	Driver block (by MVCC pin)
		+100	mA	by PIOOUT pin
Storage Temperature Range	TSTG	-55 to +125	°C	
Operating Temperature Range	TOPE	-20 to +85	°C	
Permissible Dissipation *1	PD	1370	mW	

*1 To use at a temperature higher than Ta=25 °C, derate 13.7mW per 1 °C
(At mounting 50mm x 58mm x 1.75mm glass epoxy board.)

●Recommended Operating Rating (Ta=25°C)

Parameter	Symbol	Limit	Unit	Remark
Digital Power Supply Voltage	DVDD	2.7 to 3.6	V	$DVDD \leq MVCC$
Driver Power Supply Voltage	MVCC	2.7 to 5.5	V	
Constant Current Control Amplifier Power Supply Voltage	VDDAMP	2.7 to 5.5	V	
Clock Operating Frequency	FCLK	1 to 27.5	MHz	Reference clock

●Electrical Characteristics

(Unless otherwise specified, Ta=25°C, DVDD=3.0V, MVCC=5.0V, VDDAMP=5.0V, DVSS=MGND=0.0V)

Parameter	Symbol	Limit			Unit	Conditions
		MIN	TYP	MAX		
<Current Consumption>						
Quiescence (DVDD)	ISSD	-	30	100	μA	CMD_RS=0
(MVCC)	ISSVM	-	0	10	μA	
Operation (DVDD)	IDDD	-	8.5	15.0	mA	CMD_RS=1
<Logic Block>						
Low-level Input Voltage	VIL	DVSS	-	0.3DVDD	V	
High-level Input Voltage	VIH	0.7DVDD	-	DVDD	V	
Low-level Input Current	IIL	0	-	10	μA	VIL=DVSS
High-level Input Current	IIH	0	-	10	μA	VIH=DVDD
Low-level Output Voltage	VOL	DVSS	-	0.2DVDD	V	IOL=1.0mA
High-level Output Voltage	VOH	0.8DVDD	-	DVDD	V	IOH=1.0mA
<PI Driving Circuit>						
Output Voltage	PIVO	-	0.28	0.50	V	IIH=50mA
<Waveforming Circuit 1ch>						
Detective Voltage Range	Vth	0.5	-	2.5	V	SI1
Detective Voltage Error	V	1/2DVDD-0.1	1/2DVDD	1/2DVDD+0.1	V	Waveforming Vth = 20h setting
<Waveforming Circuit 2ch,3ch>						
High-level Threshold Voltage	VthH1	-	-	1.9	V	SI2,SI3(DVDD=3.25V) Hys ON
Low-level Threshold Voltage	VthL1	0.6	-	-	V	SI2,SI3(DVDD=3.25V) Hys ON
Hysteresis Width	HYS	0.2	-	0.6	V	SI2,SI3(DVDD=3.25V) Hys ON
Threshold Voltage	VthH2	1.0	-	1.85	V	SI2,SI3(DVDD=3.25V) Hys OFF
<Voltage Driver Block>						
ON-resistance	Ron	-	1.5	2.0	Ω	IO=±100mA (the sum of high and low sides)
OFF-leak Current	IOZ	-10	0	+10	μA	Output Hiz setting
Turn-ON Time	tON	-	0.15	1.0	μS	
Turn-OFF Time	tOFF	-	0.1	0.5	μS	
Average Voltage Accuracy between different Output Pins	Vdiff	-5	-	+5	%	Vdiff = 2.0V setting.
<Current Driver Block >						
ON-resistance	Ron	-	0.9	1.5	Ω	IO=±100mA (the sum of high and low sides)
OFF-leak Current	IOZ	-10	0	+10	μA	Output Hiz setting
Output Voltage	VO	188	200	212	mV	DAC setting : A7h RRNF=1Ω
Turn-ON Time	tON	-	0.15	1.0	μS	
Turn-OFF Time	tOFF	-	0.1	0.5	μS	

● Typical Performance Curves

(Unless otherwise specified, Ta=25°C, DVDD=3.0V, MVCC=5.0V, DVSS=MGND=0.0V)

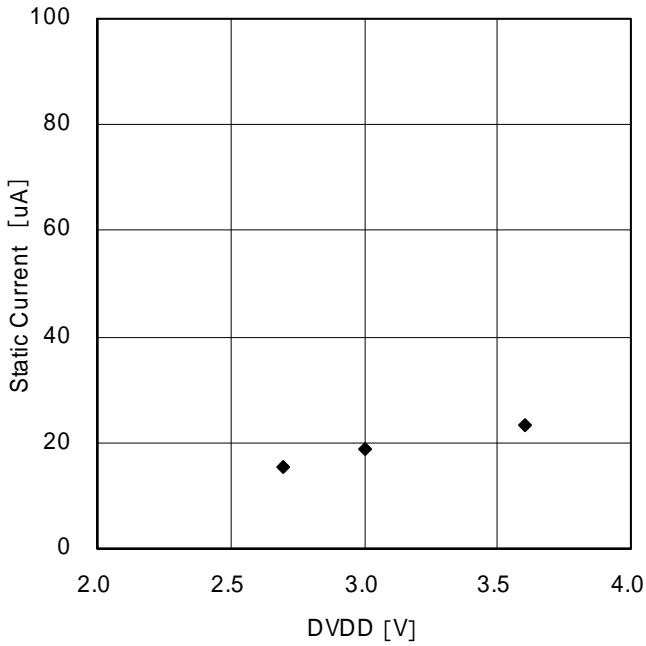

Figure 1. DVDD Static Current Voltage Dependency

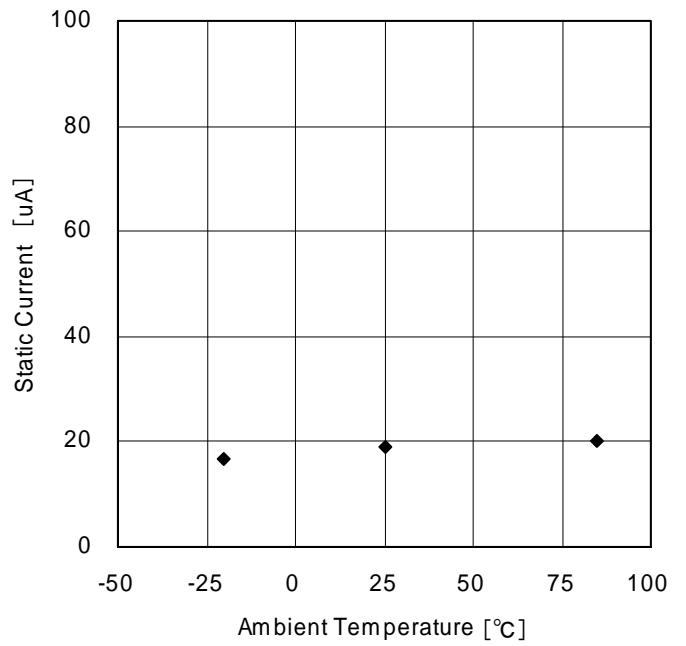

Figure 2. DVDD Static Current Temperature Dependency

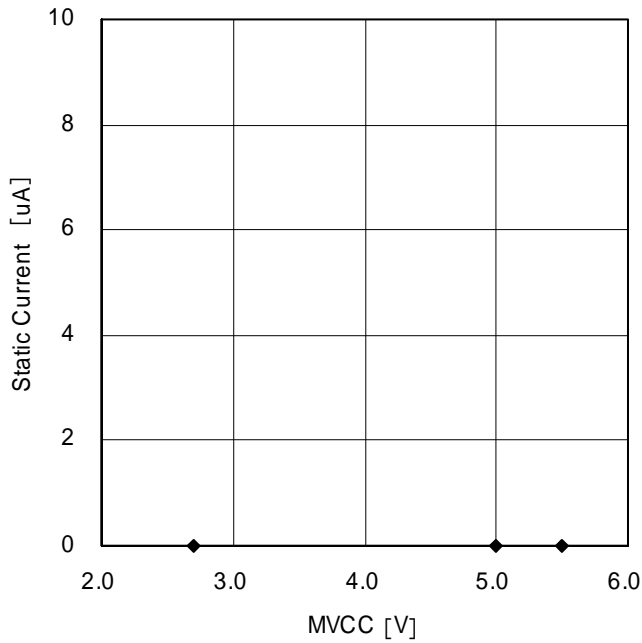

Figure 3. MVCC Static Current Voltage Dependency

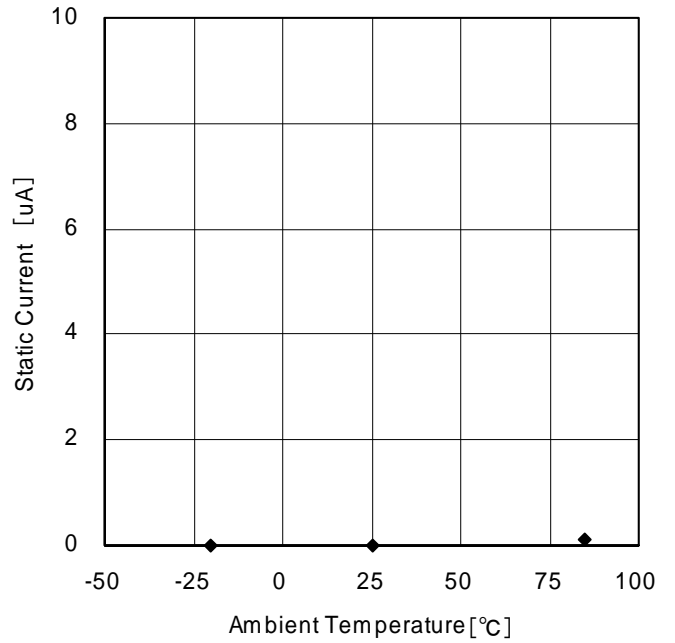

Figure 4. MVCC Static Current Temperature Dependency

● Typical Performance Curves

(Unless otherwise specified, $T_a=25^\circ\text{C}$, $DVDD=3.0\text{V}$, $MVCC=5.0\text{V}$, $DVSS=MGND=0.0\text{V}$)

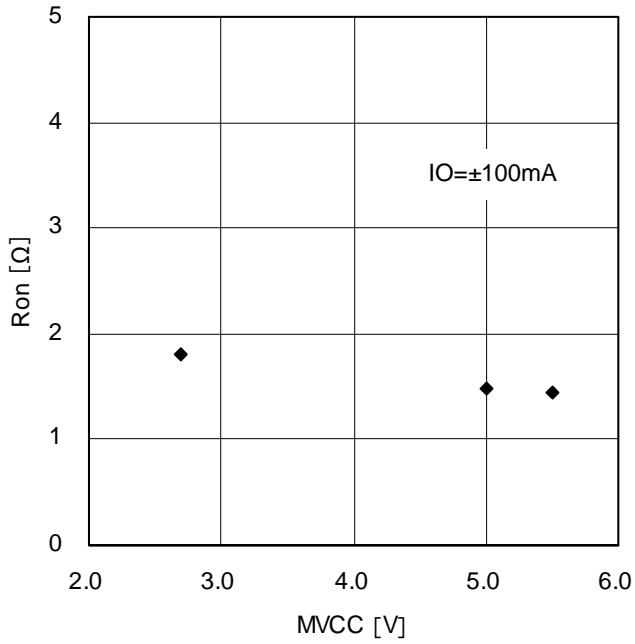

Figure 5. Output ON-Resistance
MVCC Dependency
(Voltage driver block)

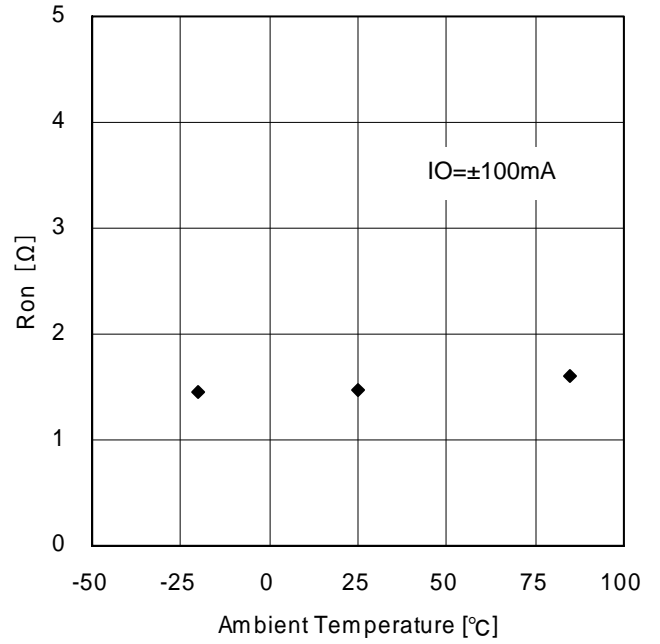

Figure 6. Output ON-Resistance
Temperature Dependency
(Voltage driver block)

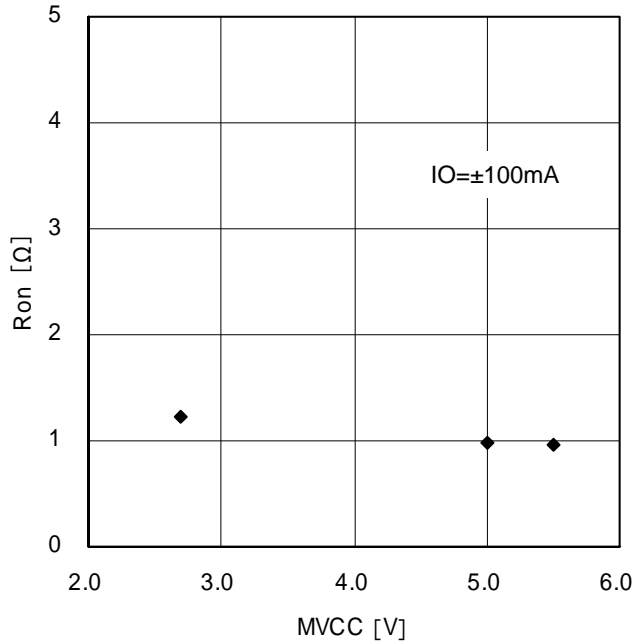

Figure 7. Output ON-Resistance
MVCC Dependency
(Current driver block)

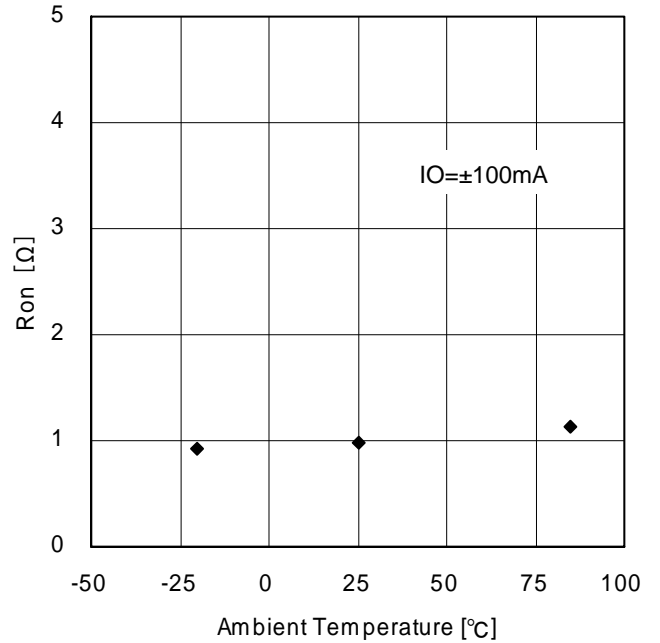

Figure 8. Output ON-Resistance
Temperature Dependency
(Current driver block)

● Typical Performance Curves

(Unless otherwise specified, $T_a=25^{\circ}\text{C}$, $\text{DVDD}=3.0\text{V}$, $\text{MVCC}=5.0\text{V}$, $\text{DVSS}=\text{MGND}=0.0\text{V}$)

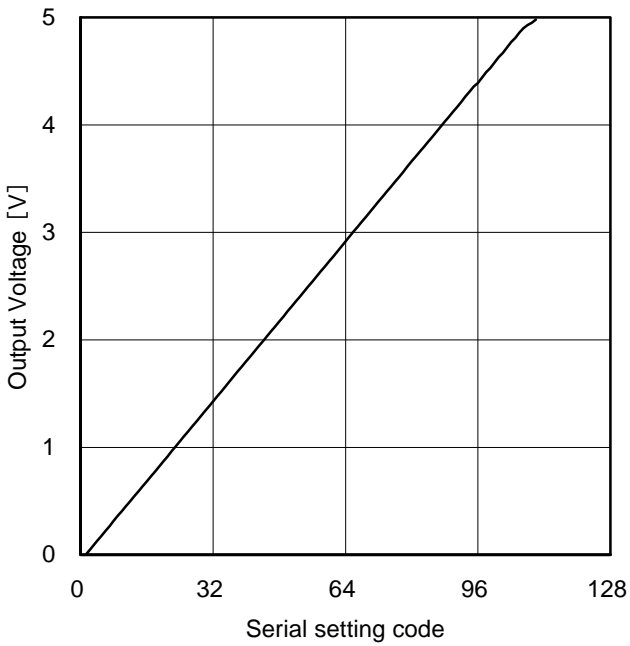

Figure 9. Average Voltage Accuracy between different output pins (Voltage driver block)

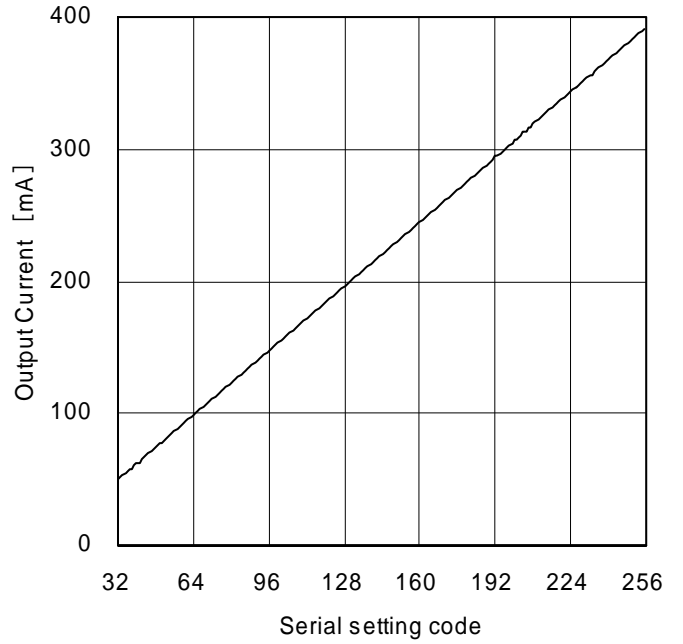

Figure 10. Output Current (Current driver block, $\text{RRNF} = 1.0\Omega$, $\text{RL} = 5.0\Omega$)

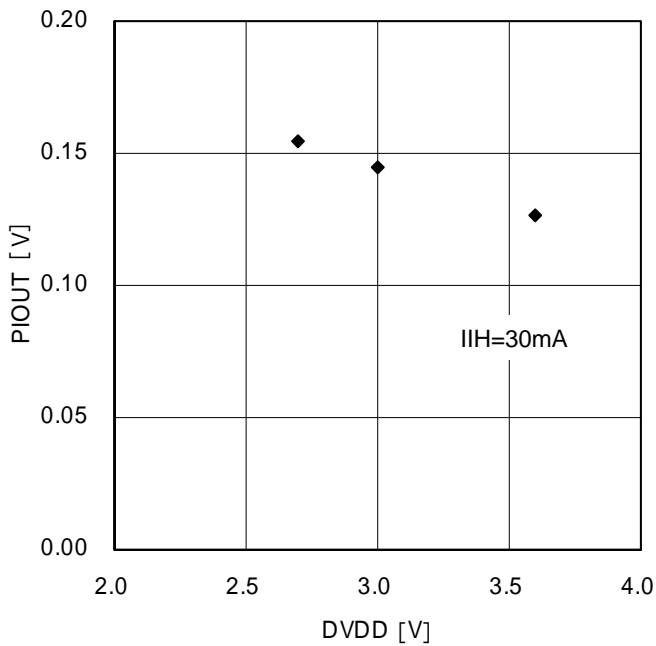

Figure 11. Output Voltage DVDD Dependency (PI driving circuit)

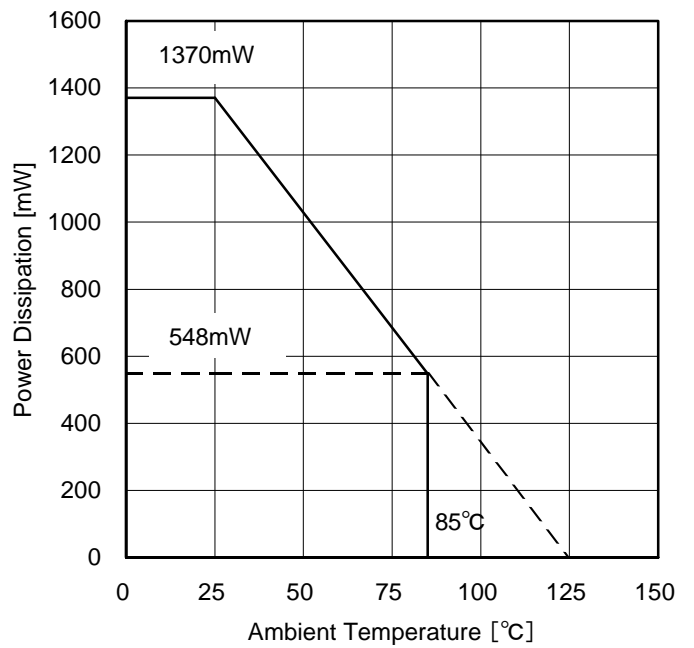
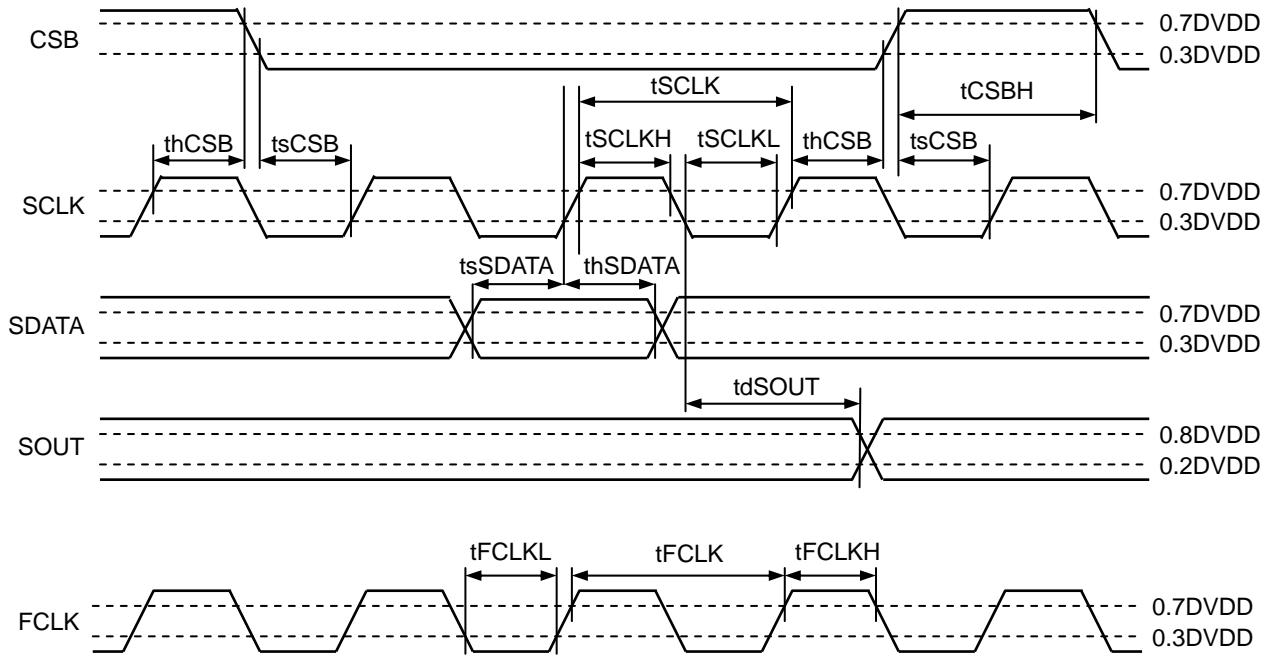

Figure 12. Power Dissipation Curve

●Timing Chart

(Unless otherwise specified, Ta=25°C, DVDD=3.0V)

Parameter	Symbol	Specification
SCLK input cycle	tSCLK	more than 125 nsec
SCLK L-level input time	tSCLKL	more than 50 nsec
SCLK H-level input time	tSCLKH	more than 50 nsec
SDATA setup time	tsSDATA	more than 50 nsec
SDATA hold time	thSDATA	more than 50 nsec
CSB H-level input time	tCSBH	more than 800 nsec
CSB setup time	tsCSB	more than 50 nsec
CSB hold time	thCSB	more than 50 nsec
SOUT output delay time	tdSOUT	more than 50 nsec
FCLK input cycle	tFCLK	more than 36 nsec
FCLK L-level input time	tFCLKL	more than 18 nsec
FCLK H-level input time	tFCLKH	more than 18 nsec



(note1) FCLK is asynchronous with SCLK.
 (note2) Duty of FCLK, SCLK are free.

●Serial interface

Control commands are framed by a 16-bit serial input (MSB first) and are sent through the CSB, SCLK, and SDATA pins. The 4 higher-order bits specify addresses, while the remaining 12 bits specify data. Data of every bit is sent through SDATA pin, which is retrieved during the rising edge of SCLK. Data becomes valid when CSB is Low and is registered during the rising edge of CSB. (as shown in "Note 5,6") Furthermore, the interface will be synchronized with the falling edges of SCLK to output the SOUT data of the 12 bits.

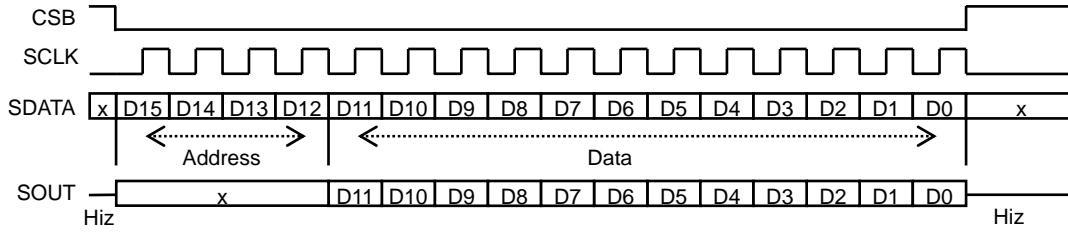

<Register map>

Address[3:0]				Data[11:0]											
14	13	12	11	10	9	8	7	6	5	4	3	2	1	0	
0	0	0	0	ModeA[1:0]		SelA[1:0]		0	Ach_different_output_voltage[6:0]						
0	0	0	1	0	0	0	0	Ach_Cycle[7:0]							
				0	0	1	0	Ach_Cycle[15:8]							
				1	1	1	0	0	APOS[1:0]	0	0	0	ASTOP		
0	0	1	0	EnA	RtA	Ach_Pulse[9:0]									
0	0	1	1	Ach status[1:0]			Ach operation pulse number[9:0]								
0	1	0	0	ModeB[1:0]		SelB[1:0]		0	Bch_different_output_voltage[6:0]						
0	1	0	1	0	0	0	0	Bch Cycle[7:0]							
				0	0	1	0	Bch Cycle[15:8]							
				1	1	1	0	0	BPOS[1:0]	0	0	0	BSTOP		
0	1	1	0	EnB	RtB	Bch_Pulse[9:0]									
0	1	1	1	Bch status[1:0]			Bch operation pulse number[9:0]								
1	0	0	0	ModeC[1:0]		SelC[1:0]		0	Cch_different_output_voltage[6:0]						
1	0	0	1	0	0	0	0	Cch_Cycle[7:0]							
				0	0	1	0	Cch_Cycle[15:8]							
				1	0	1	5_PWM_Ct[1:0]		5ch_different_output_voltage[6:0]						
				1	1	0	6_PWM_Ct[1:0]		6ch_different_output_voltage[6:0]						
				1	1	1	0	0	C_POS[1:0]	0	0	0	CSTOP		
1	0	1	0	EnC	RtC	Cch_Pulse[9:0]									
1	0	1	1	Cch status[1:0]			Cch operation pulse number[9:0]								
1	1	0	0	0	0	Chopping[1:0]	CacheM	SEL56[2:0]		P_CTRL	CLK_DIV[2:0]				
1	1	0	1	0	0	0	0	0	0	0	0	0	PI_CTRL1	PI_CTRL2	
				0	0	1	0	0	5_PULSE_CNT	5_PULSE_BASE[1:0]		0	6_PULSE_CNT	6_PULSE_BASE[1:0]	
				0	1	0	0	5_PULSE_COUNT[7:0]							
				0	1	0	1	6_PULSE_COUNT[7:0]							
				0	1	1	0	0	EXT_EN	0	EXT_RT	EXT_NUM[3:0]			
				1	0	0	0	EXT_PAT1				EXT_PAT0			
				1	0	0	1	EXT_PAT3				EXT_PAT2			
				1	0	1	0	EXT_PAT5				EXT_PAT4			
				1	0	1	1	EXT_PAT7				EXT_PAT6			
				1	1	0	0	EXT_PAT9				EXT_PAT8			
				1	1	0	1	EXT_PAT11				EXT_PAT10			
1	1	1	0	EXT_PAT13				EXT_PAT12							
1	1	1	1	EXT_PAT15				EXT_PAT14							
1	1	1	0	Constant current driver reference voltage adjustment 8bit DAC[7:0]											
				0	1	0	0	0	0	0	0	0	0	0	7_CTRL[1:0]
				1	0	0	0	0	wavefoming circuit 1 Vth[5:0]						
				1	0	0	1	0	wavefoming circuit 1 Vthl[5:0]						
				1	0	1	0	0	0	0	0	0	0	HYS3	HYS2
				1	1	0	0	0	0	0	0	0	0	0	CMD_RS
Addresses other than those above				Setting prohibited											

- (Note 1) The notations A, B, C in the register map corresponds to Ach, Bch and Cch respectively.
- (Note 2) The Ach is defined as 1ch and 2ch driver output, the Bch as 3ch and 4ch driver output, and the Cch as 5ch and 6ch driver output.
- (Note 3) After reset (Power ON reset, and CMD_RS), "initial setting" is saved in all registers.
- (Note 4) The addresses 4'b0011, 4'b0111, and 4'b1011 have data (status [1:0], operation pulse number [9:0]), which are internal register values and output from the SOUT pin.
- (Note 5) For Mode, different output voltage, Cycle, En, and Rt registers, data that are written before the access to the Pulse register becomes valid, and determines the rising edge of CSB after the access to the Pulse register. (The Mode, different output voltage, Cycle, En, Rt, and Pulse registers contain Cache registers. Any registers other than those do not contain Cache registers.)
- (Note 6) For POS, STOP, PWM_Ct, and different output voltage registers, data are determined at the rising edge of CSB. For any registers other than those, data are determined at the rising edge of 16th SCLK.

●Application Example

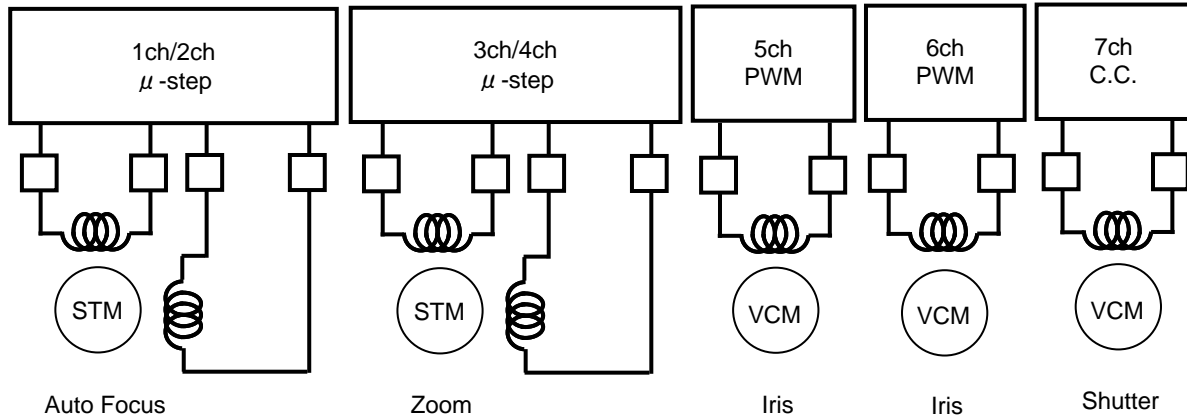
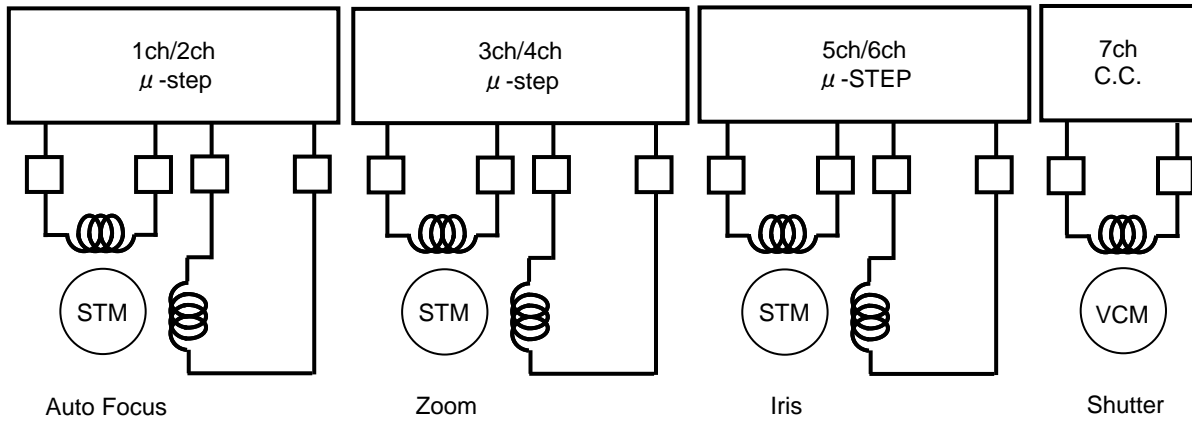

● I/O Equivalence Circuit

Pin	Equivalent Circuit Diagram	Pin	Equivalent Circuit Diagram
FCLK CSB SCLK SDATA IN56 IN7 SI2 SI3 * SI2,SI3 are the Schmitt inputs.		SENSE	
SOUT STATE1 STATE2 SO1 SO2 SO3		PIOUT1 PIOUT2	
OUT1A OUT1B OUT2A OUT2B		OUT3A OUT3B OUT4A OUT4B	
OUT5A OUT5B OUT6A OUT6B		OUT7A OUT7B RNF	
STATE3		SI1	

●Operational Notes

- 1) Absolute maximum ratings
If applied voltage, operating temperature range, or other absolute maximum ratings are exceeded, the LSI may be damaged. Do not apply voltages or temperatures that exceed the absolute maximum ratings. If you expect that any voltage or temperature could be exceeding the absolute maximum ratings, take physical safety measures such as fuses to prevent any conditions exceeding the absolute maximum ratings from being applied to the LSI.
- 2) GND potential
The voltage of the ground pin must be the lowest voltage of all pins of the IC at all operating conditions. Ensure that no pins are at a voltage below the ground pin at any time, even during transient condition.
- 3) Thermal design
Use a thermal design that allows for a sufficient margin by taking into account the permissible power dissipation (PD) in actual operating conditions.
- 4) Short circuit between pins and malfunctions
Ensure that when mounting the IC on the PCB the direction and position are correct. Incorrect mounting may result in damaging the IC. Avoid nearby pins being shorted to each other especially to ground. Inter-pin shorts could be due to many reasons such as metal particles, water droplets (in very humid environment) and unintentional solder bridge deposited in between pins during assembly to name a few.
- 5) Operation in strong magnetic field
Operating the IC in the presence of a strong electromagnetic field may cause the IC to malfunction.
- 6) Power ON sequence
To turn ON the DVDD, be sure to reset at CMD_RS register.
- 7) Thermal shutdown
The IC incorporates a built-in thermal shutdown circuit, which is designed to turn off the IC when the internal temperature of the IC reaches a specified value. It is not designed to protect the IC from damage or guarantee its operation. Do not continue to operate the IC after this function is activated. Do not use the IC in conditions where this function will always be activated.
- 8) PI drive circuit
The output voltage of PIOOUT should not exceed the voltage of the power supply voltage DVDD.

● Ordering Information

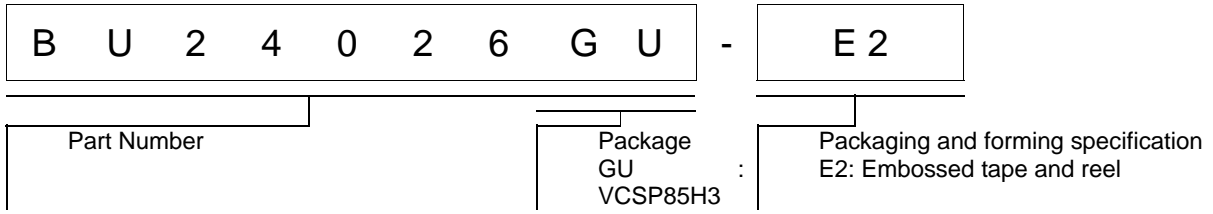

● Marking Diagram

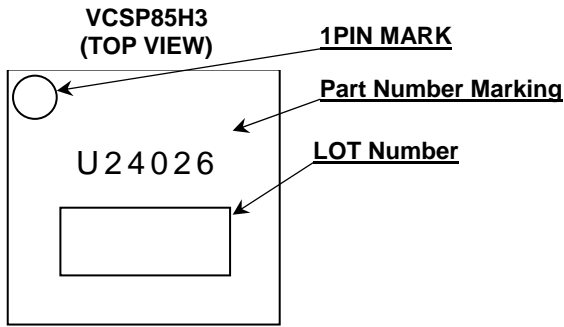

●Physical Dimension Tape and Reel Information

Package Name	VCSP85H3
--------------	----------

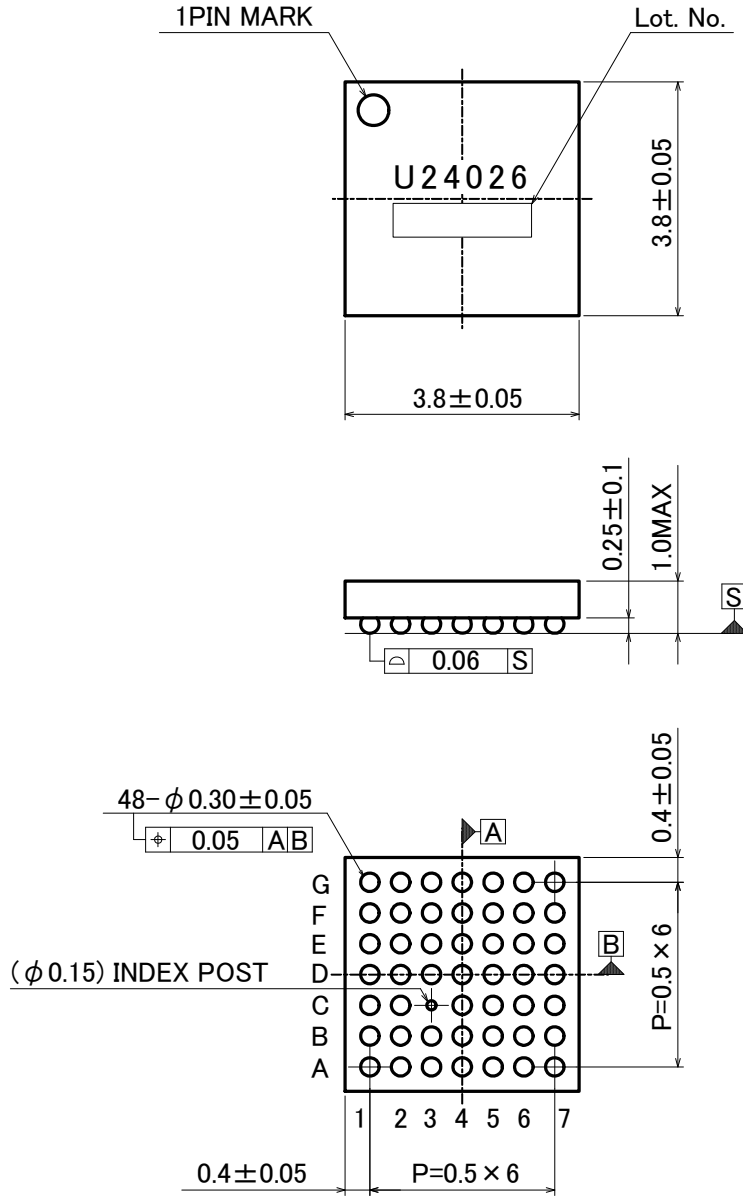

Tape	Embossed carriertape
Quantity	2,500pcs/Reel
Direction of feed	E2 (The direction is 1pin product is at the upper left when you hold reel on the hand and you pull out the tape on the right hand)

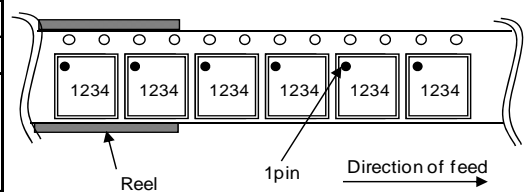

●Revision History

Date	Revision	Changes
26.Sep.2012	001	New Release
18.Apr.2013	002	Update some English words, sentences, descriptions, grammar and formatting.

Notice

Precaution on using ROHM Products

- Our Products are designed and manufactured for application in ordinary electronic equipments (such as AV equipment, OA equipment, telecommunication equipment, home electronic appliances, amusement equipment, etc.). If you intend to use our Products in devices requiring extremely high reliability (such as medical equipment ^(Note 1), transport equipment, traffic equipment, aircraft/spacecraft, nuclear power controllers, fuel controllers, car equipment including car accessories, safety devices, etc.) and whose malfunction or failure may cause loss of human life, bodily injury or serious damage to property ("Specific Applications"), please consult with the ROHM sales representative in advance. Unless otherwise agreed in writing by ROHM in advance, ROHM shall not be in any way responsible or liable for any damages, expenses or losses incurred by you or third parties arising from the use of any ROHM's Products for Specific Applications.

(Note1) Medical Equipment Classification of the Specific Applications

JAPAN	USA	EU	CHINA
CLASS III	CLASS III	CLASS II b	CLASS III
CLASS IV		CLASS III	

- ROHM designs and manufactures its Products subject to strict quality control system. However, semiconductor products can fail or malfunction at a certain rate. Please be sure to implement, at your own responsibilities, adequate safety measures including but not limited to fail-safe design against the physical injury, damage to any property, which a failure or malfunction of our Products may cause. The following are examples of safety measures:
 - Installation of protection circuits or other protective devices to improve system safety
 - Installation of redundant circuits to reduce the impact of single or multiple circuit failure
- Our Products are designed and manufactured for use under standard conditions and not under any special or extraordinary environments or conditions, as exemplified below. Accordingly, ROHM shall not be in any way responsible or liable for any damages, expenses or losses arising from the use of any ROHM's Products under any special or extraordinary environments or conditions. If you intend to use our Products under any special or extraordinary environments or conditions (as exemplified below), your independent verification and confirmation of product performance, reliability, etc. prior to use, must be necessary:
 - Use of our Products in any types of liquid, including water, oils, chemicals, and organic solvents
 - Use of our Products outdoors or in places where the Products are exposed to direct sunlight or dust
 - Use of our Products in places where the Products are exposed to sea wind or corrosive gases, including Cl₂, H₂S, NH₃, SO₂, and NO₂
 - Use of our Products in places where the Products are exposed to static electricity or electromagnetic waves
 - Use of our Products in proximity to heat-producing components, plastic cords, or other flammable items
 - Sealing or coating our Products with resin or other coating materials
 - Use of our Products without cleaning residue of flux (even if you use no-clean type fluxes, cleaning residue of flux is recommended); or Washing our Products by using water or water-soluble cleaning agents for cleaning residue after soldering
 - Use of the Products in places subject to dew condensation
- The Products are not subject to radiation-proof design.
- Please verify and confirm characteristics of the final or mounted products in using the Products.
- In particular, if a transient load (a large amount of load applied in a short period of time, such as pulse. is applied, confirmation of performance characteristics after on-board mounting is strongly recommended. Avoid applying power exceeding normal rated power; exceeding the power rating under steady-state loading condition may negatively affect product performance and reliability.
- De-rate Power Dissipation (Pd) depending on Ambient temperature (Ta). When used in sealed area, confirm the actual ambient temperature.
- Confirm that operation temperature is within the specified range described in the product specification.
- ROHM shall not be in any way responsible or liable for failure induced under deviant condition from what is defined in this document.

Precaution for Mounting / Circuit board design

- When a highly active halogenous (chlorine, bromine, etc.) flux is used, the residue of flux may negatively affect product performance and reliability.
- In principle, the reflow soldering method must be used; if flow soldering method is preferred, please consult with the ROHM representative in advance.

For details, please refer to ROHM Mounting specification

Precautions Regarding Application Examples and External Circuits

1. If change is made to the constant of an external circuit, please allow a sufficient margin considering variations of the characteristics of the Products and external components, including transient characteristics, as well as static characteristics.
2. You agree that application notes, reference designs, and associated data and information contained in this document are presented only as guidance for Products use. Therefore, in case you use such information, you are solely responsible for it and you must exercise your own independent verification and judgment in the use of such information contained in this document. ROHM shall not be in any way responsible or liable for any damages, expenses or losses incurred by you or third parties arising from the use of such information.

Precaution for Electrostatic

This Product is electrostatic sensitive product, which may be damaged due to electrostatic discharge. Please take proper caution in your manufacturing process and storage so that voltage exceeding the Products maximum rating will not be applied to Products. Please take special care under dry condition (e.g. Grounding of human body / equipment / solder iron, isolation from charged objects, setting of Ionizer, friction prevention and temperature / humidity control).

Precaution for Storage / Transportation

1. Product performance and soldered connections may deteriorate if the Products are stored in the places where:
 - [a] the Products are exposed to sea winds or corrosive gases, including Cl₂, H₂S, NH₃, SO₂, and NO₂
 - [b] the temperature or humidity exceeds those recommended by ROHM
 - [c] the Products are exposed to direct sunshine or condensation
 - [d] the Products are exposed to high Electrostatic
2. Even under ROHM recommended storage condition, solderability of products out of recommended storage time period may be degraded. It is strongly recommended to confirm solderability before using Products of which storage time is exceeding the recommended storage time period.
3. Store / transport cartons in the correct direction, which is indicated on a carton with a symbol. Otherwise bent leads may occur due to excessive stress applied when dropping of a carton.
4. Use Products within the specified time after opening a humidity barrier bag. Baking is required before using Products of which storage time is exceeding the recommended storage time period.

Precaution for Product Label

QR code printed on ROHM Products label is for ROHM's internal use only.

Precaution for Disposition

When disposing Products please dispose them properly using an authorized industry waste company.

Precaution for Foreign Exchange and Foreign Trade act

Since our Products might fall under controlled goods prescribed by the applicable foreign exchange and foreign trade act, please consult with ROHM representative in case of export.

Precaution Regarding Intellectual Property Rights

1. All information and data including but not limited to application example contained in this document is for reference only. ROHM does not warrant that foregoing information or data will not infringe any intellectual property rights or any other rights of any third party regarding such information or data. ROHM shall not be in any way responsible or liable for infringement of any intellectual property rights or other damages arising from use of such information or data.:
2. No license, expressly or implied, is granted hereby under any intellectual property rights or other rights of ROHM or any third parties with respect to the information contained in this document.

Other Precaution

1. This document may not be reprinted or reproduced, in whole or in part, without prior written consent of ROHM.
2. The Products may not be disassembled, converted, modified, reproduced or otherwise changed without prior written consent of ROHM.
3. In no event shall you use in any way whatsoever the Products and the related technical information contained in the Products or this document for any military purposes, including but not limited to, the development of mass-destruction weapons.
4. The proper names of companies or products described in this document are trademarks or registered trademarks of ROHM, its affiliated companies or third parties.

General Precaution

1. Before you use our Products, you are requested to carefully read this document and fully understand its contents. ROHM shall not be in any way responsible or liable for failure, malfunction or accident arising from the use of any ROHM's Products against warning, caution or note contained in this document.
2. All information contained in this document is current as of the issuing date and subject to change without any prior notice. Before purchasing or using ROHM's Products, please confirm the latest information with a ROHM sales representative.
3. The information contained in this document is provided on an "as is" basis and ROHM does not warrant that all information contained in this document is accurate and/or error-free. ROHM shall not be in any way responsible or liable for any damages, expenses or losses incurred by you or third parties resulting from inaccuracy or errors of or concerning such information.

Компания «Океан Электроники» предлагает заключение долгосрочных отношений при поставках импортных электронных компонентов на взаимовыгодных условиях!

Наши преимущества:

- Поставка оригинальных импортных электронных компонентов напрямую с производств Америки, Европы и Азии, а так же с крупнейших складов мира;
- Широкая линейка поставок активных и пассивных импортных электронных компонентов (более 30 млн. наименований);
- Поставка сложных, дефицитных, либо снятых с производства позиций;
- Оперативные сроки поставки под заказ (от 5 рабочих дней);
- Экспресс доставка в любую точку России;
- Помощь Конструкторского Отдела и консультации квалифицированных инженеров;
- Техническая поддержка проекта, помощь в подборе аналогов, поставка прототипов;
- Поставка электронных компонентов под контролем ВП;
- Система менеджмента качества сертифицирована по Международному стандарту ISO 9001;
- При необходимости вся продукция военного и аэрокосмического назначения проходит испытания и сертификацию в лаборатории (по согласованию с заказчиком);
- Поставка специализированных компонентов военного и аэрокосмического уровня качества (Xilinx, Altera, Analog Devices, Intersil, Interpoint, Microsemi, Actel, Aeroflex, Peregrine, VPT, Syfer, Eurofarad, Texas Instruments, MS Kennedy, Miteq, Cobham, E2V, MA-COM, Hittite, Mini-Circuits, General Dynamics и др.);

Компания «Океан Электроники» является официальным дистрибьютором и эксклюзивным представителем в России одного из крупнейших производителей разъемов военного и аэрокосмического назначения «JONHON», а так же официальным дистрибьютором и эксклюзивным представителем в России производителя высокотехнологичных и надежных решений для передачи СВЧ сигналов «FORSTAR».



JONHON

«JONHON» (основан в 1970 г.)

Разъемы специального, военного и аэрокосмического назначения:

(Применяются в военной, авиационной, аэрокосмической, морской, железнодорожной, горно- и нефтедобывающей отраслях промышленности)

«FORSTAR» (основан в 1998 г.)

ВЧ соединители, коаксиальные кабели, кабельные сборки и микроволновые компоненты:

(Применяются в телекоммуникациях гражданского и специального назначения, в средствах связи, РЛС, а так же военной, авиационной и аэрокосмической отраслях промышленности).



Телефон: 8 (812) 309-75-97 (многоканальный)

Факс: 8 (812) 320-03-32

Электронная почта: ocean@oceanchips.ru

Web: <http://oceanchips.ru/>

Адрес: 198099, г. Санкт-Петербург, ул. Калинина, д. 2, корп. 4, лит. А