

MAX77801

High-Efficiency Buck-Boost Regulator

General Description

The MAX77801 is a high-current, high-efficiency buck-boost targeted to mobile applications that use a Li-ion battery or similar chemistries. The MAX77801 utilizes a four-switch H-bridge configuration to support buck and boost operating modes. Buck-boost provides 2.60V to 4.1875V of output voltage range and up to 2A output current.

A unique control algorithm allows high efficiency, outstanding performances in line/load transient response, and seamless transition between buck and boost modes.

DVS (dynamic voltage scaling) input allows the host processor to switch between two preprogrammed output voltages. This feature minimizes power loss for given load conditions. The ramp-up and ramp-down slew rates are programmable through I²C.

The MAX77801 features I²C-compatible, 2-wire serial interface consisting of a bidirectional serial-data line (SDA) and a serial-clock line (SCL). It supports SCL clock rates up to 3.4MHz.

Applications

- Smartphones and Tablets
- Battery-Powered Applications

Benefits and Features

- 2A High-Efficiency Buck and Boost Operation Including Seamless Transition Between Buck and Boost Mode
- Flexibility Supports Various Designs
 - V_{OUT} Range from 2.60V to 4.1875V with 12.5mV Step
 - High-Speed (Up to 3.4MHz) I²C Serial Interface
- Low Quiescent Current, High Efficiency, and Dynamic Voltage Scaling Enable System to Be More Efficient
 - DVS Input
 - Up to 97% of Peak Efficiency
 - 55µA Quiescent Current
- High Switching Frequency and Small Package Reduce Solution Size
 - 2.5MHz Switching Frequency
 - 20-Bump WLP (0.4mm Pitch)
- Safety Features Enhance Device and System Reliability
 - POK Output
 - Soft-Start
 - True Shutdown™
 - Thermal Shutdown and Short-Circuit Protection

Typical Application Circuit

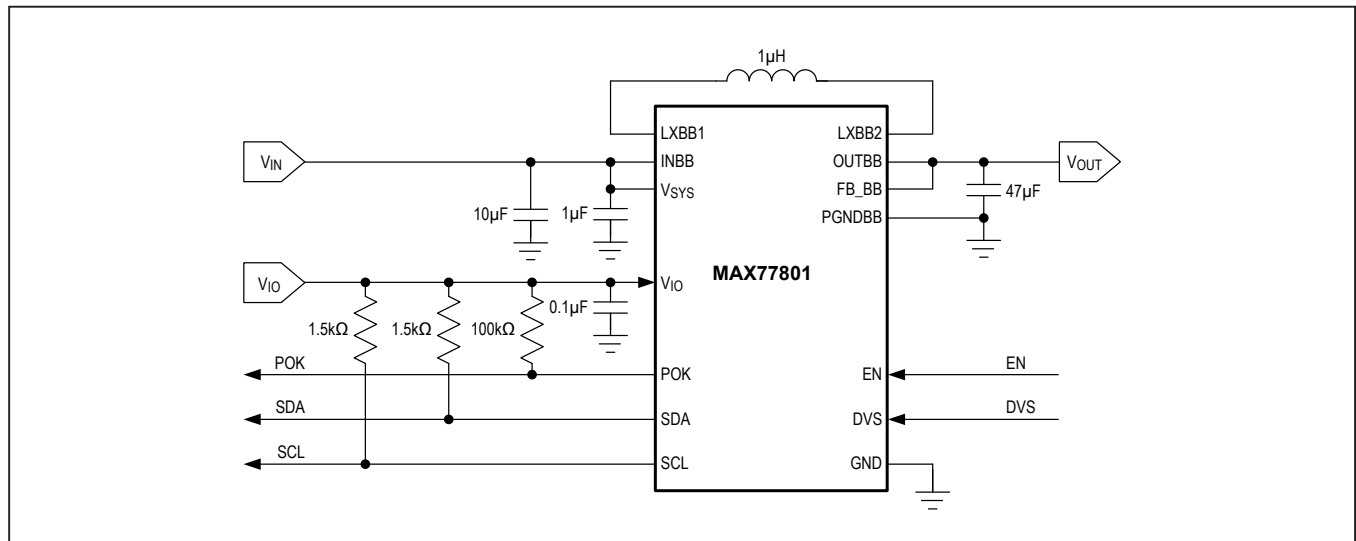

Ordering Information appears at end of data sheet.

True Shutdown is a trademark of Maxim Integrated Products, Inc.

Absolute Maximum Ratings

SYS, V _{IO} to GND.....	-0.3V to +6.0V	LXBB2 to PGNDDB.....	-0.3V to (V _{OUTBB} + 0.3V)
INBB, OUTBB to PGNDDB.....	-0.3V to +6.0V	LXBB1/LXBB2 Continuous RMS Current (Note 1).....	3.3A
PGNDDB to GND.....	-0.3V to +0.3V	Operating Temperature Range.....	-40°C to +85°C
SCL, SDA to GND.....	-0.3V to (V _{IO} + 0.3V)	Junction Temperature.....	+150°C
EN, DVS, POK to GND.....	-0.3V to (V _{SYS} + 0.3V)	Storage Temperature Range.....	-65°C to +150°C
FB_BB to GND.....	-0.3V to (V _{OUTBB} + 0.3V)	Soldering Temperature (reflow).....	+260°C
LXBB1 to PGNDDB.....	-0.3V to (V _{INBB} + 0.3V)		

Note 1: LXBB1/LXBB2 node has internal clamp diodes to PGNDDB and INBB. Applications that give forward bias to these diodes should ensure that the total power loss does not exceed the power dissipation limit of IC package.

Stresses beyond those listed under "Absolute Maximum Ratings" may cause permanent damage to the device. These are stress ratings only, and functional operation of the device at these or any other conditions beyond those indicated in the operational sections of the specifications is not implied. Exposure to absolute maximum rating conditions for extended periods may affect device reliability.

Package Thermal Characteristics (Note 2)

Junction-to Ambient Thermal Resistance (θ_{JA}).....55.49°C/W

Note 2: Package thermal resistances were obtained using the method described in JEDEC specification JESD51-7, using a four-layer board. For detailed information on package thermal considerations, refer to www.maximintegrated.com/thermal-tutorial.

Buck-Boost Electrical Characteristics

(V_{SYS} = V_{INBB} = +3.8V, V_{FB_BB} = V_{OUTBB} = +3.3V, T_A = -40°C to +85°C, typical values are at T_A = +25°C, unless otherwise noted.) (Note 3)

PARAMETER	SYMBOL	CONDITIONS	MIN	TYP	MAX	UNITS
GENERAL						
Input Voltage Range	V _{INBB}		2.3		5.5	V
Shutdown Supply Current	I _{SHDN_25C}	EN = low, T _A = +25°C		0.1		µA
	I _{SHDN_85C}	EN = low, T _A = +85°C		1		µA
Input Supply Current	I _{Q_SKIP}	SKIP mode, no switching		55	70	µA
	I _{Q_PWM}	FPWM mode, no load		6		mA
Active Discharge Resistance	R _{DISCHG}			100		Ω
Thermal Shutdown	T _{SHDN}	Rising, 20°C hysteresis		+165		°C
H-BRIDGE						
Output Voltage Range	V _{OUT}	I ² C programmable (12.5mV step)	2.60		4.1875	V
Default Output Voltage		VOUT_DVS_L[6:0] = 0x38		3.3		V
		VOUT_DVS_H[6:0] = 0x40		3.4		V
Output Voltage Accuracy	V _{OUT_ACC1}	PWM mode, BB_VOUT_DVS_x[6:0] = 0x40, no load	-1.0		+1.0	%
	V _{OUT_ACC2}	SKIP mode, BB_VOUT_DVS_x[6:0] = 0x40, no load, T _A = +25°C	-1.0		+4.5	%

Buck-Boost Electrical Characteristics (continued)

($V_{SYS} = V_{INBB} = +3.8V$, $V_{FB_BB} = V_{OUTBB} = +3.3V$, $T_A = -40^{\circ}C$ to $+85^{\circ}C$, typical values are at $T_A = +25^{\circ}C$, unless otherwise noted.)
(Note 3)

PARAMETER	SYMBOL	CONDITIONS	MIN	TYP	MAX	UNITS
Line Regulation		$V_{INBB} = 2.3V$ to $5.5V$		0.200		%/V
Load Regulation		(Note 4)		0.125		%/A
Line Transient Response	V_{OS1} V_{US1}	$I_{OUT} = 1.5A$, V_{INB} changes from $3.4V$ to $2.9V$ in $25\mu s$ ($20mV/\mu s$), $L = 1\mu H$, $C_{OUT_NOM} = 47\mu F$ (Note 4)		50		mV
Load Transient Response	V_{OS2} V_{US2}	$V_{INBB} = 3.4V$, I_{OUT} changes from $10mA$ to $1.5A$ in $15\mu s$, $L = 1\mu H$, $C_{OUT_NOM} = 47\mu F$ (Note 4)		50		mV
Output Voltage Ramp-Up Slew Rate		$BB_RU_SR = 0$		12.5		mV/ μs
		$BB_RU_SR = 1$		25		mV/ μs
Output Voltage Ramp-down Slew Rate		$BB_RD_SR = 0$		3.125		mV/ μs
		$BB_RD_SR = 1$		6.25		mV/ μs
Typical Load Efficiency	η_{IOUT_TYP}	$I_{OUT} = 100mA$, $V_{INBB} = 3.6V$ (Note 4)		95		%
Peak Efficiency	η_{PK}	(Note 4)		97		%
Maximum Output Current	$I_{OUT(MAX)}$	$2.8V \leq V_{INBB} \leq 5.5V$		2000		mA
	$I_{OUT(MAX)}$	$2.3V \leq V_{INBB} < 2.8V$		1000		mA
LXBB1/2 Current Limit	I_{LIM_LXBB}		3.70	4.70	5.70	A
High-Side PMOS ON Resistance	R_{DSON} (PMOS)	$I_{LXBB} = 100mA$ per switch		40		m Ω
Low-Side NMOS ON Resistance	R_{DSON} (NMOS)	$I_{LXBB} = 100mA$ per switch		55		m Ω
Switching Frequency	f_{SW}	PWM mode, $T_A = +25^{\circ}C$	2.25	2.50	2.75	MHz
Turn-On Delay Time	t_{ON_DLY}	From EN asserting to LXBB switching with bias ON		100		μs
Soft-Start Time	t_{SS}	$I_{OUT} = 10mA$		120		μs
Minimum Effective Output Capacitance	$C_{EFF(MIN)}$	$0A < I_{OUT} < 2000mA$		16		μF
LXBB1, LXBB2 Leakage Current	I_{LK_25}	$V_{LXBB1/2} = 0V$ or $5.5V$, $V_{OUTBB} = 5.5V$, $V_{SYS} = V_{INBB} = 5.5V$, $T_A = +25^{\circ}C$		0.1	1	μA
	I_{LK_85}	$V_{LXBB1/2} = 0V$ or $5.5V$, $V_{OUTBB} = 5.5V$, $V_{SYS} = V_{INBB} = 5.5V$, $T_A = +85^{\circ}C$		0.2		μA
POWER-OK COMPARATOR						
Output POK Trip Level		Rising threshold		80		%
		Falling threshold		75		%

Buck-Boost Electrical Characteristics (continued)

($V_{SYS} = V_{INBB} = +3.8V$, $V_{FB_BB} = V_{OUTBB} = +3.3V$, $T_A = -40^{\circ}C$ to $+85^{\circ}C$, typical values are at $T_A = +25^{\circ}C$, unless otherwise noted.) (Note 3)

PARAMETER	SYMBOL	CONDITIONS	MIN	TYP	MAX	UNITS
V_{SYS} UNDERVOLTAGE LOCKOUT						
V _{SYS} Undervoltage Lockout Threshold	V _{UVLO_R}	V _{SYS} rising	2.375	2.50	2.625	V
	V _{UVLO_F}	V _{SYS} falling (default)		2.05		V
LOGIC AND CONTROL INPUTS						
Input Low Level	V _{IL}	EN, DVS, V _{SYS} ≤ 4.5V, T _A = +25°C			0.4	V
Input High Level	V _{IH}	EN, DVS, V _{SYS} ≤ 4.5V, T _A = +25°C	1.2			V
POK Output Low Voltage	V _{OL}	I _{SINK} = 1mA			0.4	V
POK Output High Leakage	I _{OZH_25C}	T _A = +25°C	-1		+1	μA
	I _{OZH_85C}	T _A = +85°C		0.1		μA
INTERNAL PULLDOWN RESISTANCE						
EN, DVS	RPD	Pulldown resistor to GND	400	800	1600	kΩ

I²C Electrical Characteristics

(V_{SYS} = 3.8V, V_{IO} = 1.8V, T_A = -40°C to +85°C, typical values are at T_A = +25°C, unless otherwise noted.) (Note 3)

PARAMETER	SYMBOL	CONDITIONS	MIN	TYP	MAX	UNITS
POWER SUPPLY						
V _{IO} Voltage Range	V _{IO}		1.7		3.6	V
SDA AND SCL I/O STAGES						
SCL, SDA Input High Voltage	V _{IH}		0.7 x V _{IO}			V
SCL, SDA Input Low Voltage	V _{IL}				0.3 x V _{IO}	V
SCL, SDA Input Hysteresis	V _{HYS}			0.05 x V _{IO}		V
SCL, SDA Input Current	I _I	V _{IO} = 3.8V	-10		+10	μA
SDA Output low Voltage	V _{OL}	I _{SINK} = 20mA			0.4	V
SCL, SDA Input Capacitance	C _I			10		pF
Output Fall Time from V _{IO} to 0.3 x V _{IO}	t _{OF}				120	ns
I²C-COMPATIBLE INTERFACE TIMING (STANDARD, FAST, AND FAST MODE PLUS) (Note 4)						
Clock Frequency	f _{SCL}				1000	kHz
Hold Time (REPEATED) START Condition	t _{HD;STA}		0.26			μs
SCL low Period	t _{low}		0.5			μs
SCL high Period	t _{high}		0.26			μs
Setup Time REPEATED START Condition	t _{SU_STA}		0.26			μs

I²C Electrical Characteristics (continued)(V_{SYS} = 3.8V, V_{IO} = 1.8V, T_A = -40°C to +85°C, typical values are at T_A = +25°C, unless otherwise noted.) (Note 3)

PARAMETER	SYMBOL	CONDITIONS	MIN	TYP	MAX	UNITS
DATA Hold Time	t _{HD_DAT}		0			μs
DATA Setup Time	t _{SU_DAT}		50			ns
Setup Time for STOP Condition	t _{SU_STO}		0.26			μs
Bus-Free Time Between STOP and START	t _{BUF}		0.5			μs
Capacitive Load for Each Bus Line	C _B				550	pF
Maximum Pulse Width of Spikes That Must Be Suppressed by the Input Filter				50		ns
I²C-COMPATIBLE INTERFACE TIMING (HIGH-SPEED MODE, C_B = 100pF) (Note 4)						
Clock Frequency	f _{SCL}				3.4	MHz
Set-Up Time REPEATED START Condition	t _{SU_STA}		160			ns
Hold Time (REPEATED) START Condition	t _{HD_STA}		160			ns
CLK Low Period	t _{low}		160			ns
CLK High Period	t _{high}		60			ns
DATA Setup Time	t _{SU_DAT}		10			ns
DATA Hold Time	t _{HD_DAT}			35		ns
SCL Rise Time (Note 4)	t _{RCL}	T _A = +25°C	10		40	ns
Rise Time of SCL Signal After REPEATED START Condition and After Acknowledge Bit	t _{RCL1}	T _A = +25°C	10		80	ns
SCL Fall Time	t _{FCL}	T _A = +25°C	10		40	ns
SDA Rise Time	t _{RDA}	T _A = +25°C			80	ns
SDA Fall Time	t _{FDA}	T _A = +25°C			80	ns
Setup Time for STOP Condition	t _{SU_STO}		160			ns
Bus Capacitance	C _B				100	pF
Maximum Pulse Width of Spikes That Must Be Suppressed by the Input Filter				10		ns

I²C Electrical Characteristics (continued)(V_{SYS} = 3.8V, V_{IO} = 1.8V, T_A = -40°C to +85°C, typical values are at T_A = +25°C, unless otherwise noted.) (Note 3)

PARAMETER	SYMBOL	CONDITIONS	MIN	TYP	MAX	UNITS
I²C-COMPATIBLE INTERFACE TIMING (HIGH-SPEED MODE, C_B = 400pF) (Note 4)						
Clock Frequency	f _{SCL}				1.7	MHz
Setup Time REPEATED START Condition	t _{SU_STA}		160			ns
Hold Time (REPEATED) START Condition	t _{HD_STA}		160			ns
SCL Low Period	t _{low}		320			ns
SCL High Period	t _{high}		120			ns
DATA Setup Time	t _{SU_DAT}		10			ns
DATA Hold Time	t _{HD_DAT}			75		ns
SCL Rise Time	t _{RCL}	T _A = +25°C	20		80	ns
Rise Time of SCL Signal After REPEATED START Condition and After Acknowledge Bit	t _{RCL1}	T _A = +25°C	20		160	ns
SCL Fall Time	t _{FCL}	T _A = +25°C	20		80	ns
SDA Rise Time	t _{RDA}	T _A = +25°C			160	ns
SDA Fall Time	t _{FDA}	T _A = +25°C			160	ns
Setup Time for STOP Condition	t _{SU_STO}		160			ns
Bus Capacitance	C _B				400	pF
Maximum Pulse Width of Spikes That Must Be Suppressed by the Input Filter	t _{SP}			10		ns

Note 3: Limits are 100% production tested at T_A = +25°C. Limits over the operating temperature range are guaranteed through correlation using statistical quality control methods.**Note 4:** Guaranteed by design. Not production tested.

Typical Operating Characteristics

($V_{SYS} = V_{INBB} = +3.8V$, $V_{FB_BB} = V_{OUTBB} = +3.3V$, $T_A = +25^{\circ}C$.)

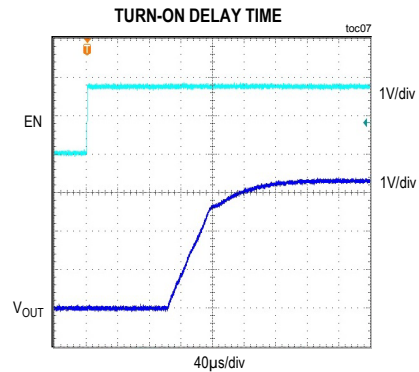
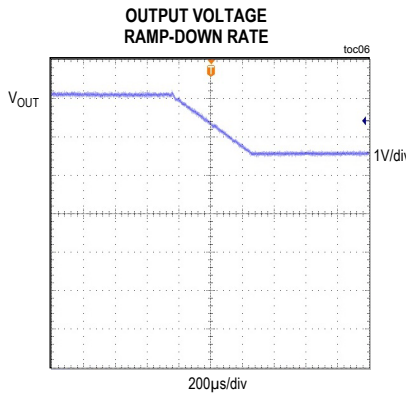
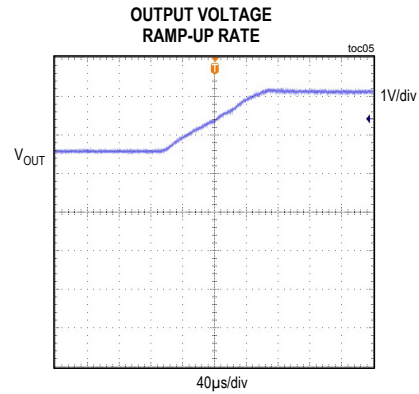
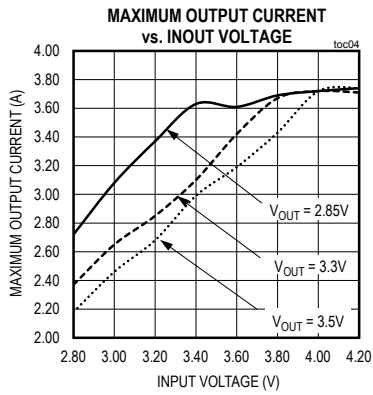
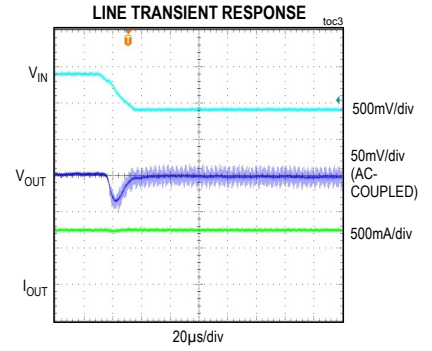
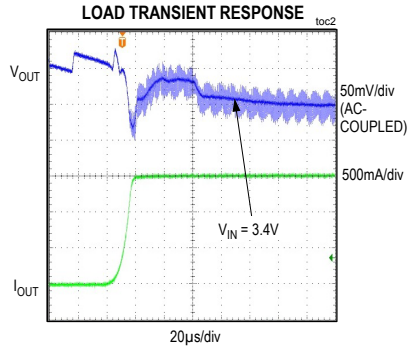
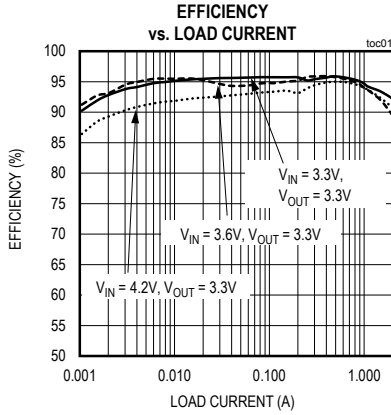

Pin Configuration

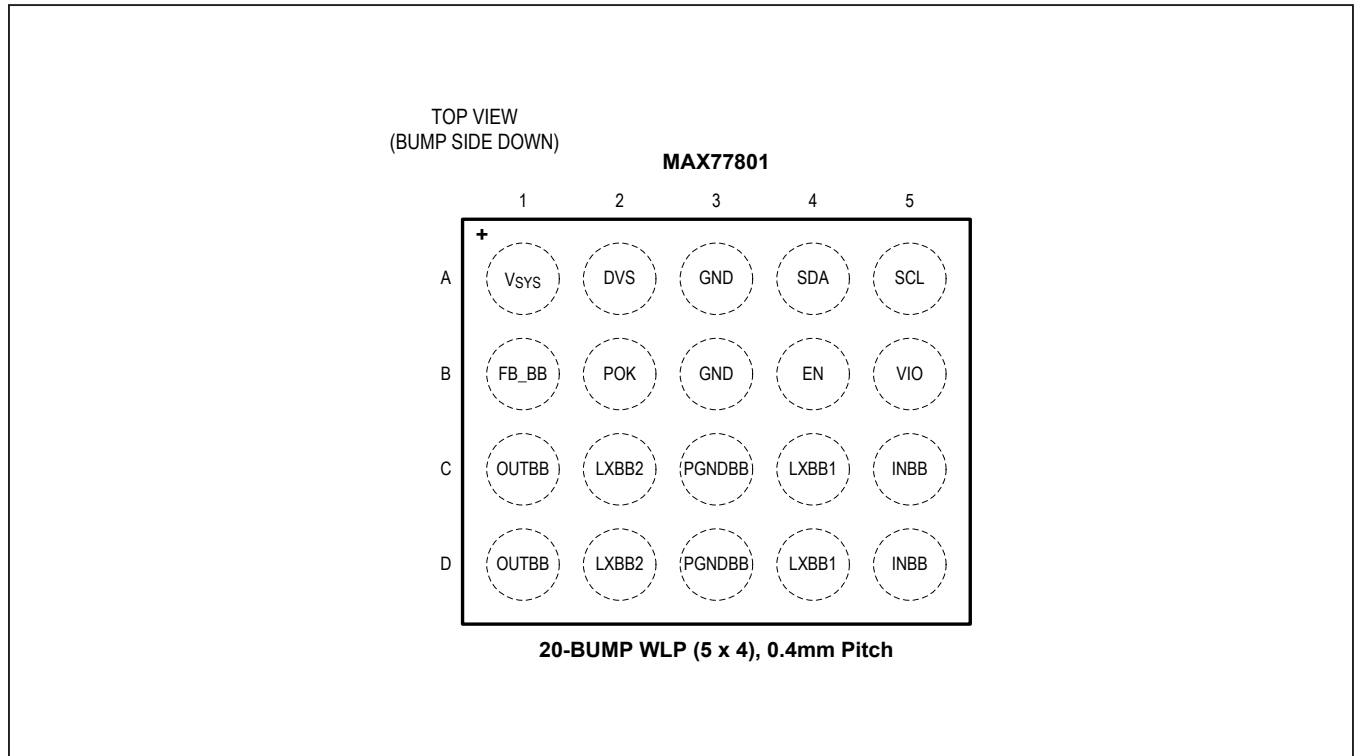

Pin Description

PIN	NAME	FUNCTION
A1	V _{SYS}	System (Battery) Voltage Input. Bypass to GND with a 1µF capacitor.
A2	DVS	Dynamic Voltage Scaling Logic Input. If not in use, then it must be connected to GND.
A3, B3	GND	Ground. Star-Ground Connection to System GND
A4	SDA	I ² C Data I/O (High Impedance in Off State). A 1.5kΩ~2.2kΩ of pullup resistor to V _{IO} is required.
A5	SCL	I ² C Clock Input (High Impedance in Off State). A 1.5kΩ~2.2kΩ of pullup resistor to V _{IO} is required.
B1	FB_BB	Buck-Boost Output Voltage Feedback
B2	POK	Power OK. Open-drain output asserted after buck-boost output reaches to 90% of output voltage. Polarity is factory selectable option. Active high by default.
B4	EN	Active-High, Buck-Boost External Enable Input. An 800kΩ internal pulldown resistance to the GND. If this pin is not used, leave it floating.
B5	V _{IO}	I ² C Supply Voltage Input. Bypass to GND with a 0.1µF capacitor. If not in use, connect to GND.
C1, D1	OUTBB	Buck-Boost Output
C2, D2	LXBB2	Buck-Boost Switching Node 2
C3, D3	PGNDBB	Buck-Boost Power Ground. Star-ground connection to system GND.
C4, D4	LXBB1	Buck-Boost Switching Node 1
C5, D5	INBB	Buck-Boost Input. Bypass to PGNDBB with a 10µF capacitor.

Detailed Description

Chip Enable (EN)

When EN pin goes high, the MAX77801 turns on the internal bias circuitry, which typically takes 85µs to settle. As soon as the bias is ready, buck-boost regulator is enabled. Once V_{IO} is supplied, then all user registers are accessible through I²C. When EN pin is pulled low, the MAX77801 goes into shutdown mode. This event also resets all type-O registers to their POR default values.

Immediate Turn-Off Events

The following events initiate immediate turn-off:

- Thermal protection ($T_J > +165^\circ\text{C}$)
- $V_{\text{SYS}} < V_{\text{SYS UVLO}}$ falling threshold ($V_{\text{UVLO_F}}$)
- Overcurrent protection

The events in this category disable buck-boost until the hazardous condition come back to normal conditions.

Regulator Enable Control

Buck-boost has GPIO enable pin EN as well as I²C enable bit. As shown in the [Table 1](#), the regulator should be enabled by EN and then it can be enabled or disabled by I²C control bit (AND logic) until EN remains in high.

Dynamic Voltage Scaling (DVS)

Buck-boost includes DVS feature that allows output voltage to change dynamically. The buck-boost output voltages are selected by DVS. When EN pin is asserted, the

Table 1. Enable Control Logic Truth Table

EN	BB_EN BIT	OPERATING MODE
low	x	Device off
high	0	Disable output
high	1 (default)	Enable output

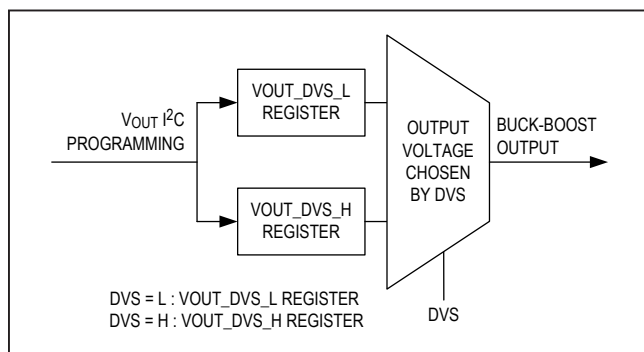

Figure 1. DVS Functional Block Diagram

status of DVS pin is latched until completing soft-start so that changes on DVS are ignored. After soft-start is done, internal logic sets V_{OUT} based on DVS input.

Buck-boost regulator supports a programmable slew-rate control feature when increasing and decreasing the output voltage. The ramp-up slew rate can be set to 12.5mV/µs or 25mV/µs through BB_RU_SR bit. Also, the ramp-down slew rate can be set to 3.125mV/µs or 6.25mV/µs through BB_RD_SR bit.

Power-OK (POK) Indicator

Buck-boost has an open-drain output that is asserted after the output voltage reaches 90%. The polarity of POK output is factory programmable option. It is active high by default.

Buck-Boost Regulator

When EN pin goes high, the MAX77801 turns on the internal bias circuitry, which typically takes 85µs to settle. As soon as the bias is ready, buck-boost regulator is enabled. Once V_{IO} is supplied, then all user registers are accessible through I²C. When EN pin is pulled low, the MAX77801 goes into shutdown mode. This event also resets all type-O registers to their POR default values.

H-Bridge Controller

H-bridge architecture operates at 2.5MHz fixed frequency with a pulse width modulated (PWM), current-mode control scheme. This topology is in a cascade of a boost regulator and a buck regulator using a single inductor and output capacitor. Buck, buck-boost, and boost stages are 100% synchronous for highest efficiency in portable applications.

There are three phases implemented with the H-bridge switch topology, as shown in [Figure 3](#):

- $\Phi 1$ switch period (Phase 1: HS1 = ON, LS2 = ON) stores energy in the inductor, ramping up the inductor current at a rate proportional to the input voltage divided by inductance, V_{INBB}/L .
- $\Phi 2$ switch period (Phase 2: HS1 = ON, HS2 = ON) ramps the inductor current up or down, depending on the differential voltage across the inductor, divided by inductance; $\pm(V_{\text{INBB}} - V_{\text{OUTBB}})/L$.
- $\Phi 3$ switch period (Phase 3: LS1 = ON, HS2 = ON) ramps down the inductor current at a rate proportional to the output voltage divided by inductance, $-V_{\text{OUTBB}}/L$.

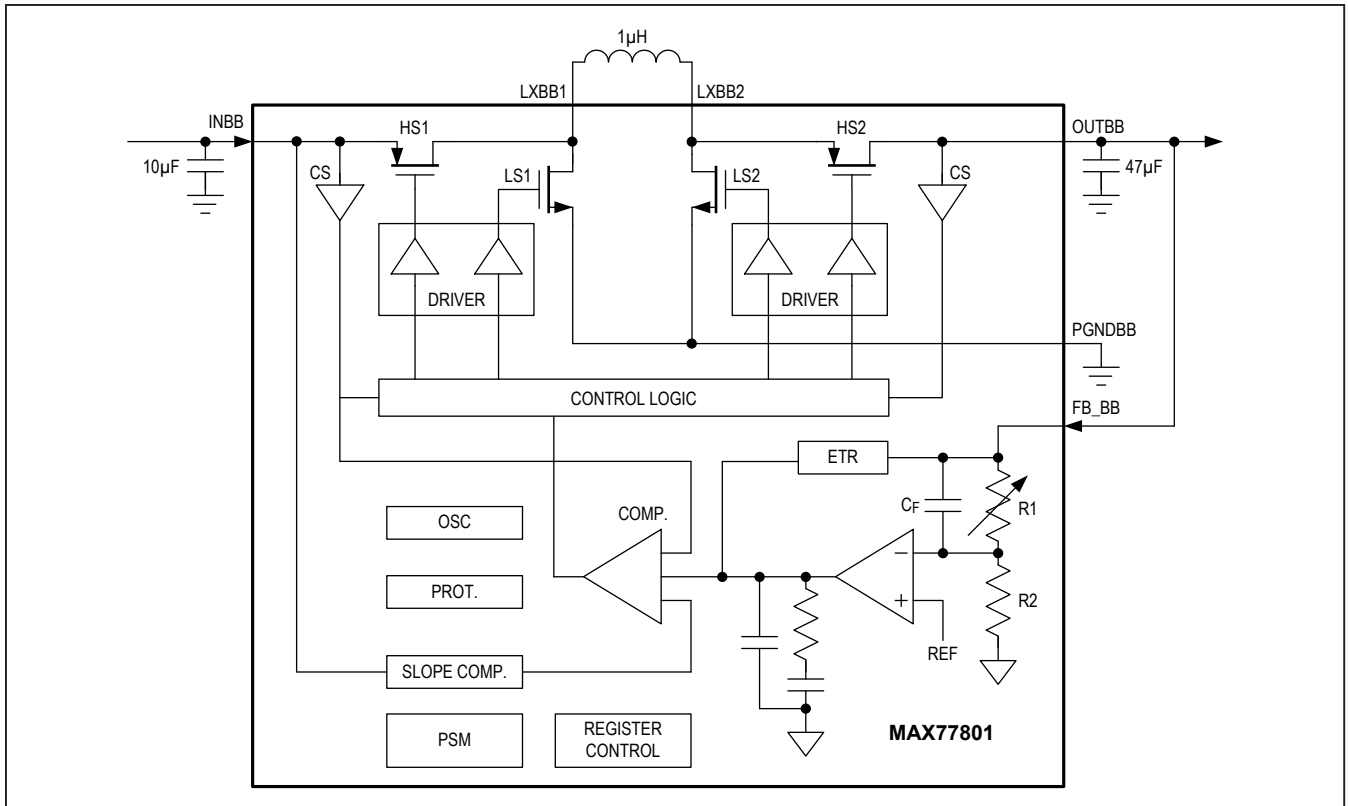

Figure 2. Buck-Boost Block Diagram

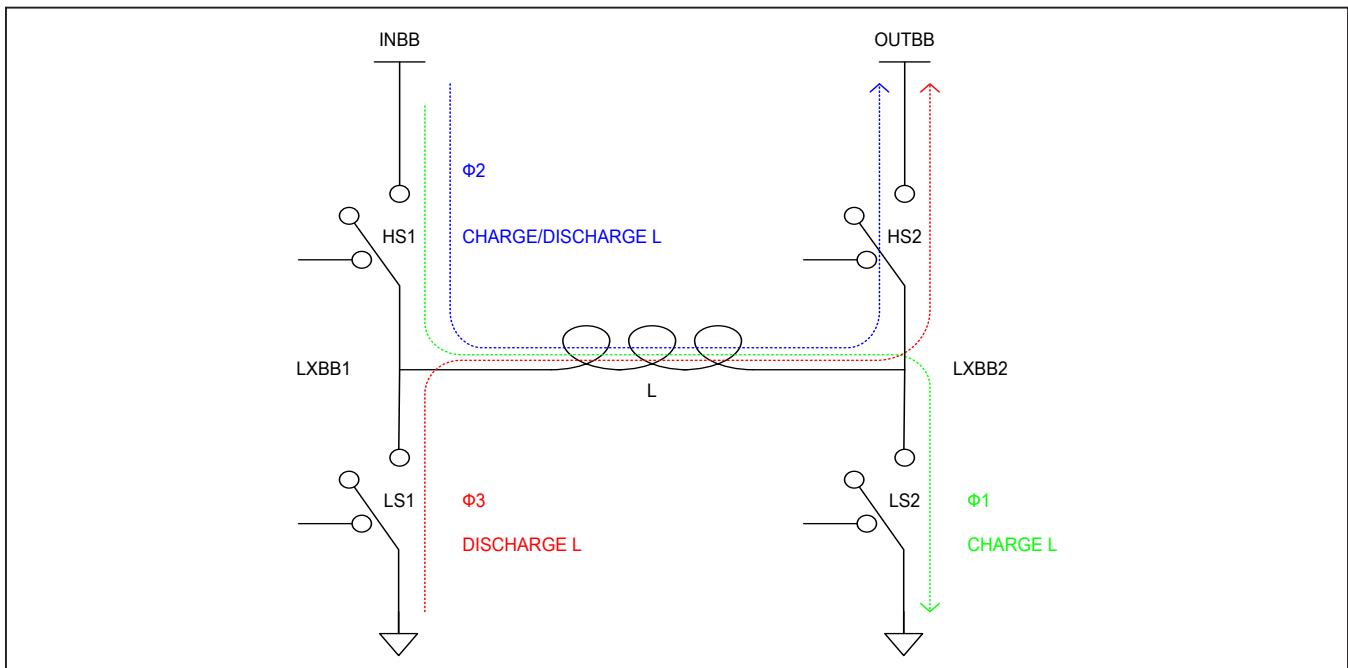

Figure 3. Buck-Boost Switching Intervals

2-phase buck topology is utilized when $V_{INBB} > V_{OUTBB}$. A switching cycle is completed in one clock period. Switch period $\Phi 2$ is followed by switch period $\Phi 3$, resulting in an inductor current waveform similar to [Figure 4](#).

2-phase boost topology is utilized when $V_{INBB} < V_{OUTBB}$. A switching cycle is completed in one clock period. Switch period $\Phi 1$ is followed by switch period $\Phi 2$, resulting in an inductor current waveform similar to [Figure 5](#).

Output Voltage Slew-rate Control

Buck-boost regulator supports programmable slew-rate control feature when increasing and decreasing the output voltage. The ramp-up slew-rate can be set to 12.5mV/ μ s or 25mV/ μ s through BB_RU_SR bit, while the ramp-down slew-rate is programmable to 3.125mV/ μ s or 6.25mV/ μ s through BB_RD_SR bit.

Output Active Discharge

Buck-boost provides an internal 100 Ω resistor for output active discharge function. If the active discharge function is enabled (BB_AD = 1), the internal resistor discharges the energy stored in the output capacitor to PGNDDB whenever the regulator is disabled.

Either the regulator remains enabled or the active discharge function is disabled (BB_AD = 0), the internal resistor is disconnected from the output. If the active discharge function is disabled, the output voltage decays at a rate that is determined by the output capacitance and the load current when the regulator is turned off.

Inductor Selection

Buck-boost is optimized for a 1 μ H inductor. The lower the inductor DCR, the higher buck-boost efficiency is. Users need to trade off inductor size with DCR value and choose a suitable inductor for buck-boost.

Input Capacitor Selection

The input capacitor, C_{IN} , reduces the current peaks drawn from the battery or input power source and reduces switching noise in the device. The impedance of C_{IN} at the switching frequency should be kept very low. Ceramic capacitors with X5R or X7R dielectrics are highly recommended due to their small size, low ESR, and small temperature coefficients. For most applications, a 10 μ F capacitor is sufficient.

Output Capacitor Selection

The output capacitor, C_{OUT} , is required to keep the output voltage ripple small and to ensure regulation loop stability. C_{OUT} must have low impedance at the switching frequency. Ceramic capacitors with X5R or X7R dielectric are highly recommended due to their small size, low ESR, and small temperature coefficients. For stable operation, buck-boost requires 16 μ F of minimum effective output capacitance. Considering DC bias characteristic of ceramic capacitors, a 47 μ F 6.3V capacitor is recommended for most of applications.

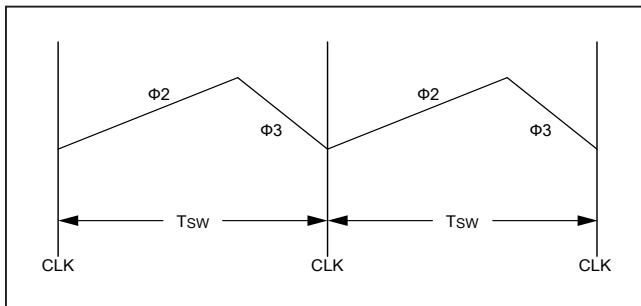

Figure 4. 2-Phase Buck Mode Switching Current Waveforms

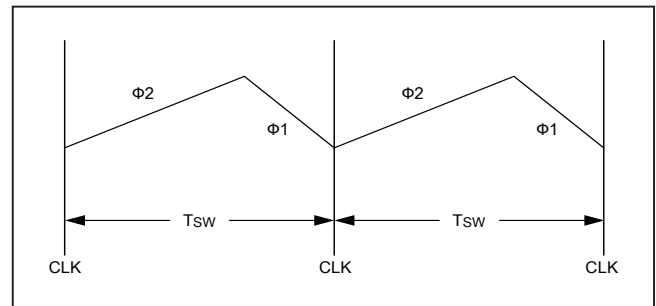

Figure 5. 2-Phase Boost Mode Switching Current Waveforms

Table 2. Suggested Inductors for Buck-Boost

MANUFACTURER	SERIES	NOMINAL INDUCTANCE (μ H)	DC RESISTANCE (typ) (m Ω)	CURRENT RATING (A) -30% (Δ L/L)	CURRENT RATING (A) Δ T = -40°C RISE	DIMENSIONS L x W x H (mm)
TDK	TFM201610GHM-1R0MTAA	1.0	50	3.8	3.0	2.0 x 1.6 x 1.0
Coilcraft	XAL4020-102MEB	1.0	13	8.7	9.6	4.0 x 4.0 x 2.1

Serial Interface

I²C compatible 2-wire serial interface is used for regulator on/off control, setting output voltages, and other functions. See the *Register Map* section for details.

I²C serial bus consists of a bidirectional serial-data line (SDA) and a serial clock (SCL). I²C is an open-drain bus. SDA and SCL require pullup resistors (500Ω or greater). Optional 24Ω resistors in series with SDA and SCL help to protect the device inputs from high voltage spikes on the bus lines. Series resistors also minimize crosstalk and undershoot on bus lines.

System Configuration

I²C bus is a multimaster bus. The maximum number of devices that can attach to the bus is only limited by bus capacitance.

The figure above shows an example of a typical I²C system. A device on I²C bus that sends data to the bus is called a transmitter. A device that receives data from the bus is called a receiver. The device that initiates a data transfer and generates SCL clock signals to control

the data transfer is the master. Any device that is being addressed by the master is considered a slave. When the MAX77801 I²C-compatible interface is operating, it is a slave on I²C bus, and it can be both a transmitter and a receiver, too.

Bit Transfer

One data bit is transferred for each SCL clock cycle. The data on SDA must remain stable during the high portion of SCL clock pulse. Changes in SDA while SCL is high are control signals (START and STOP conditions).

START and STOP Conditions

When I²C serial interface is inactive, SDA and SCL idle high. A master device initiates communication by issuing a START (S) condition. A START condition is a high-to-low transition on SDA with SCL high. A STOP (P) condition is a low-to-high transition on SDA, while SCL is high.

A START condition from the master signals the beginning of a transmission to the MAX77801. The master terminates transmission by issuing a NOT ACKNOWLEDGE (nA) followed by a STOP condition.

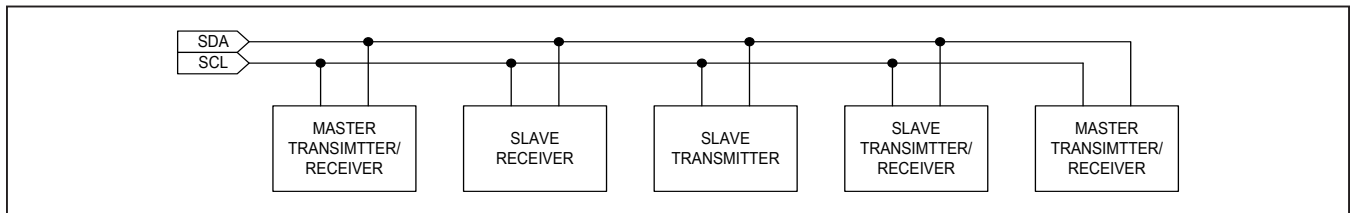

Figure 6. Functional Logic Diagram for Communications Controller

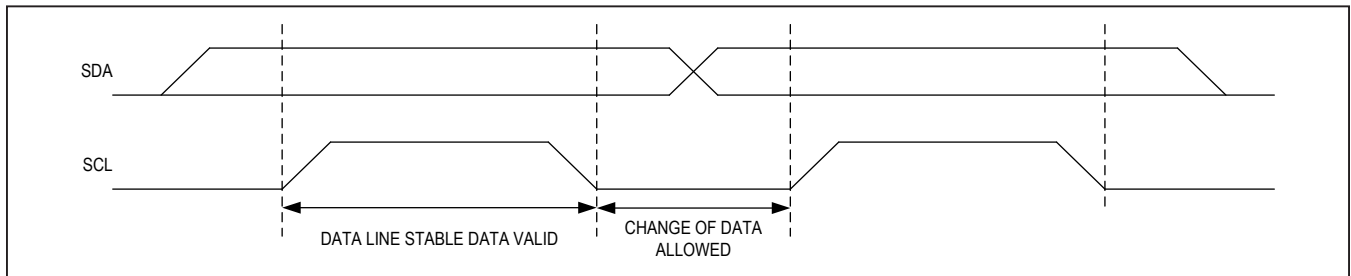

Figure 7. I²C Bit Transfer

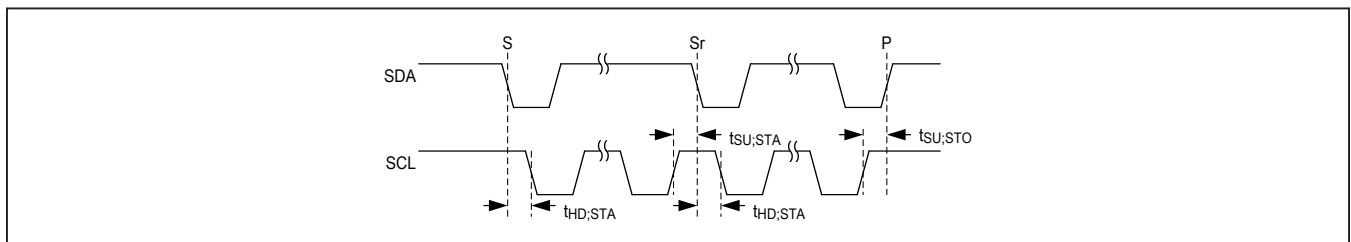

Figure 8. START and STOP Conditions

STOP condition frees the bus. To issue a series of commands to the slave, the master may issue REPEATED START (Sr) commands instead of a STOP command in order to maintain control of the bus. In general, a REPEATED START command is functionally equivalent to a regular START command.

When a STOP condition or incorrect address is detected, the MAX77801 internally disconnects SCL from I²C serial interface until the next START condition, minimizing digital noise and feedthrough.

Acknowledge

Both I²C bus master and MAX77801 (slave) generate acknowledge bits when receiving data. The acknowledge bit is the last bit of each nine bit data packet. To generate an ACKNOWLEDGE (A), the receiving device must pull SDA low before the rising edge of the acknowledge-related clock pulse (ninth pulse) and keep it low during the high period of the clock pulse. To generate a NOT ACKNOWLEDGE, the receiving device allows SDA to be pulled high before the rising edge of the acknowledge-related clock pulse and leaves it high during the high period of the clock pulse.

Monitoring the acknowledge bits allows for detection of unsuccessful data transfers. An unsuccessful data transfer occurs if a receiving device is busy or if a system fault has occurred. In the event of an unsuccessful data transfer, the bus master should reattempt communication at a later time.

Slave Address

The I²C slave address of the MAX77801 is shown in [Table 3](#).

Clock Stretching

In general, the clock signal generation for the I²C bus is the responsibility of the master device. I²C specification allows slow slave devices to alter the clock signal by holding down the clock line. The process in which a slave device holds down the clock line is typically called clock stretching. The MAX77801 does not use any form of clock stretching to hold down the clock line.

General Call Address

The MAX77801 does not implement the I²C specification called general call address. If the MAX77801 sees a general call address (0000000b), it does not issue an ACKNOWLEDGE.

Communication Speed

The MAX77801 provides I²C 3.0-compatible (3.4MHz) serial interface.

- I²C revision 3-compatible serial communications channel
 - 0Hz to 100kHz (standard mode)
 - 0Hz to 400kHz (fast mode)
 - 0Hz to 1MHz (fast mode plus)
 - 0Hz to 3.4MHz (high-speed mode)
- Does not utilize I²C clock stretching

Operating in standard mode, fast mode, and fast mode plus does not require any special protocols. The main consideration when changing the bus speed through this range is the combination of the bus capacitance and pullup resistors. Higher time constants created by the bus capacitance and pullup resistance (C x R) slow the bus operation. Therefore, when increasing bus speeds, the pullup resistance must be decreased to maintain a reasonable time constant. Refer to the *Pullup Resistor Sizing* section of I²C revision 3.0 specification for detailed guidance on the pullup resistor selection. In general, for bus capacitances of 200pF, a 100kHz bus needs 5.6kΩ pullup resistors, a 400kHz bus needs about a 1.5kΩ pullup resistors, and a 1MHz bus needs 680Ω pullup resistors. Note that the pullup resistor is dissipating power when the open-drain bus is low. The lower the value of the pullup resistor, the higher the power dissipation (V²/R).

Table 3. I²C Slave Address

SLAVE ADDRESS (7 bit)	SLAVE ADDRESS (Write)	SLAVE ADDRESS (Read)
001 1000	0x30 (0011 0000)	0x31 (0011 0001)

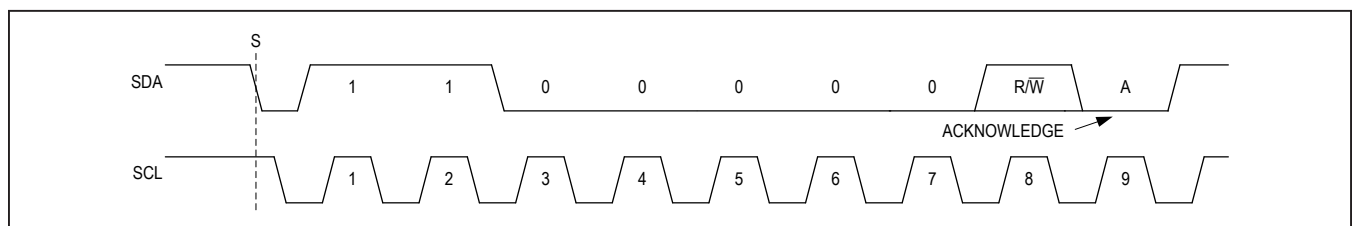

Figure 9. Slave Address Byte Example

Operating in high-speed mode requires some special considerations. For the full list of considerations, refer to the I²C 3.0 specification. The major considerations with respect to the MAX77801 are:

- I²C bus master uses current source pullups to shorten the signal rise times.
- I²C slave must use a different set of input filters on its SDA and SCL lines to accommodate for the higher bus speed.
- The communication protocols need to utilize the high-speed master code.

At power-up and after each STOP condition, the MAX77801 inputs filters are set for standard mode, fast mode, or fast mode plus (i.e., 0Hz to 1MHz). To switch the input filters for high-speed mode, use the high-speed master code protocols that are described in *Communication Protocols* section.

Communication Protocols

The MAX77801 supports both writing and reading from its registers. The following sections show the I²C communication protocols for each functional block. The power block uses the same communications protocols.

Writing to a Single Register

The figure below shows the protocol for I²C master device to write one byte of data to the MAX77801. This protocol is the same as SMBus specification's write byte protocol.

The write byte protocol is as follows:

- 1) The master sends a START command.
- 2) The master sends the 7-bit slave address followed by a write bit ($R/\overline{W} = 0$).
- 3) The addressed slave asserts an ACKNOWLEDGE by pulling SDA low.
- 4) The master sends an 8-bit register pointer.
- 5) The slave acknowledges the register pointer.
- 6) The master sends a data byte.
- 7) The slave updates with the new data.

- 8) The slave acknowledges or does not acknowledge the data byte. The next rising edge on SDA loads the data byte into its target register, and the data becomes active.
- 9) The master sends a STOP condition or a REPEATED START condition. Issuing a STOP ensures that the bus input filters are set for 1MHz or slower operation. Issuing a REPEATED START leaves the bus input filters in their current state.

Writing to a Sequential Register

The figure below shows the protocol for writing to a sequential registers. This protocol is similar to the write byte protocol, except the master continues to write after it receives the first byte of data. When the master is done writing, it issues a STOP or REPEATED START. The writing to sequential registers protocol is as follows:

1. The master sends a START command.
2. The master sends the 7-bit slave address followed by a write bit ($R/\overline{W} = 0$).
3. The addressed slave asserts an ACKNOWLEDGE by pulling SDA low.
4. The master sends an 8-bit register pointer.
5. The slave acknowledges the register pointer.
6. The master sends a data byte.
7. The slave acknowledges the data byte. The next rising edge on SDA loads the data byte into its target register and the data becomes active.
8. Steps 6 to 7 are repeated as many times as the master requires. During the last acknowledge related clock pulse, the master can issue an ACKNOWLEDGE or a NOT ACKNOWLEDGE.

The master sends a STOP condition or a REPEATED START condition. Issuing a STOP ensures that the bus input filters are set for 1MHz or slower operation. Issuing a REPEATED START leaves the bus input filters in their current state.

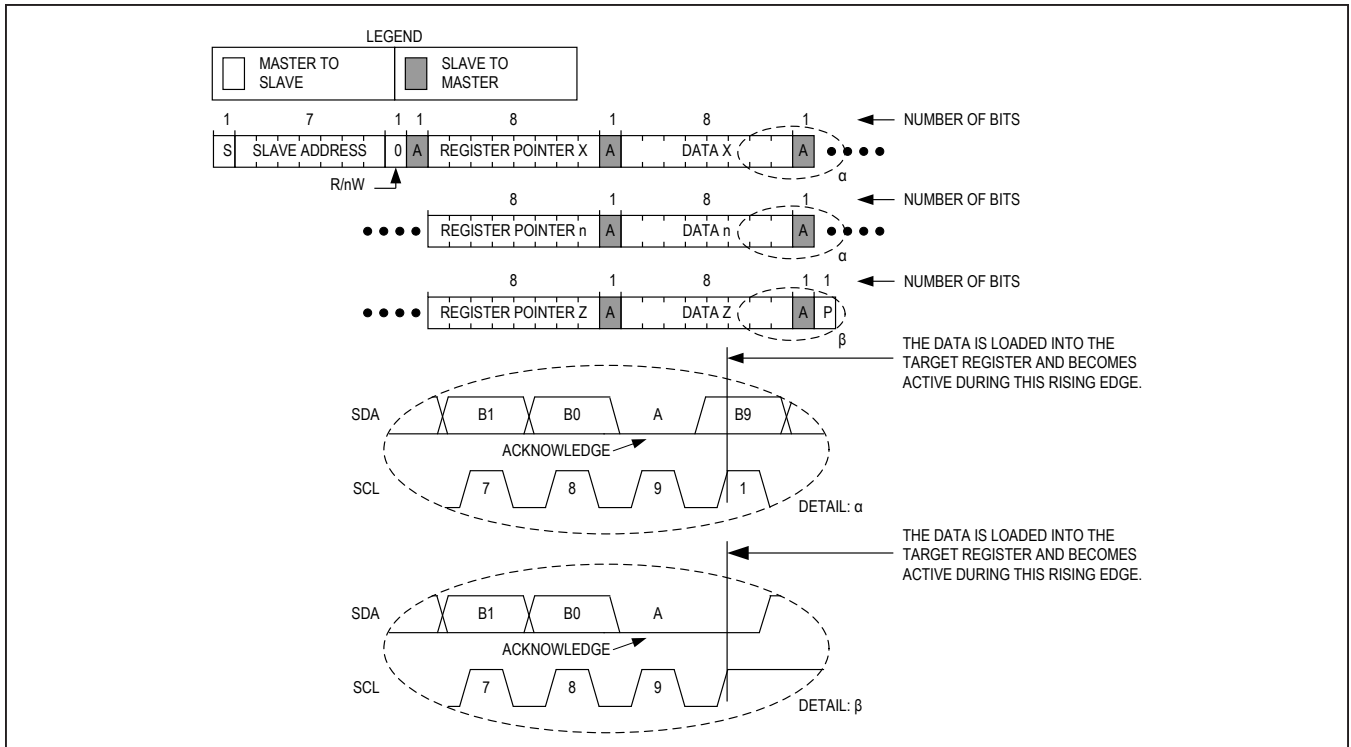

Figure 10. Writing to a Single Register with Write Byte Protocol

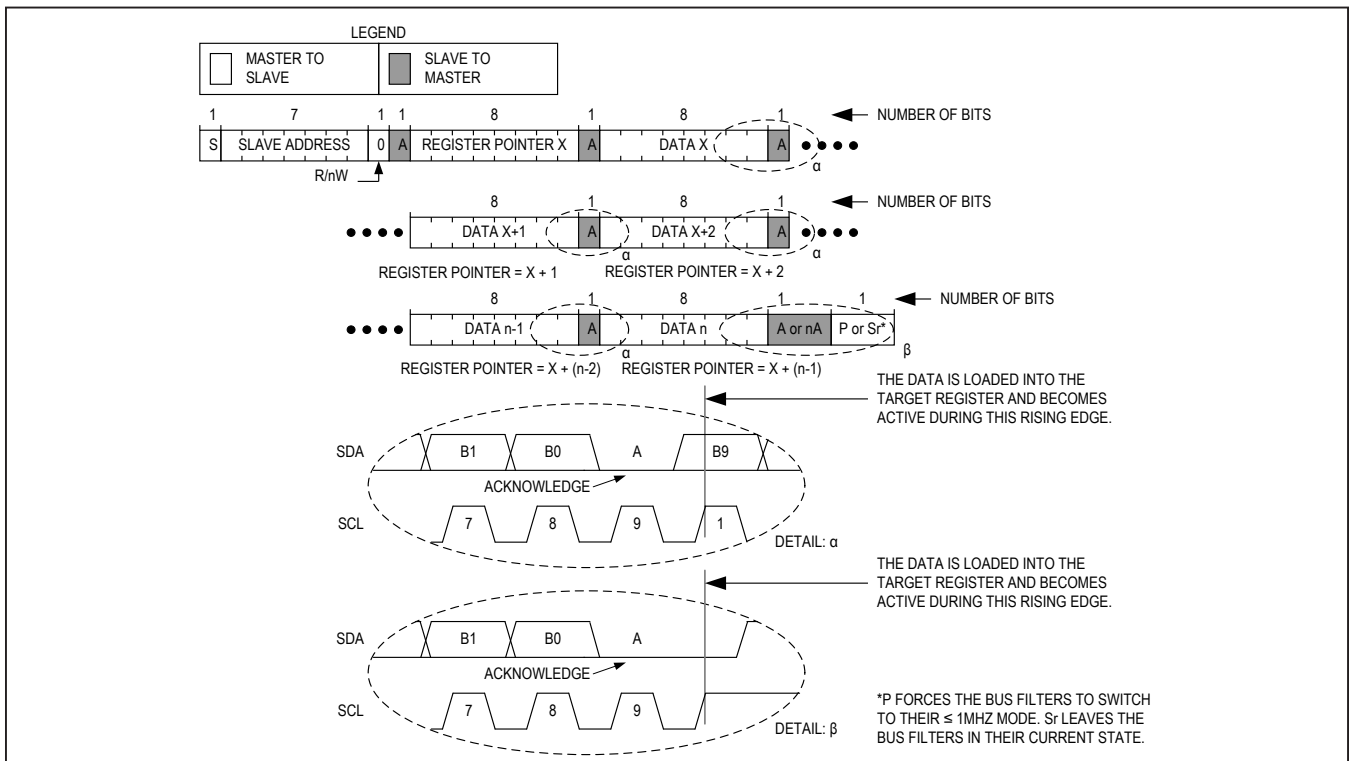

Figure 11. Writing to Sequential Registers X to N

Writing Multiple Bytes Using Register-Data Pairs

The figure below shows the protocol for I²C master device to write multiple bytes to the MAX77801 using register-data pairs. This protocol allows I²C master device to address the slave only once and then send data to multiple registers in a random order. Registers can be written continuously until the master issues a STOP condition.

The multiple byte register-data pair protocol is as follows:

1. The master sends a START command.
2. The master sends the 7-bit slave address followed by a write bit.
3. The addressed slave asserts an ACKNOWLEDGE by pulling SDA low.
4. The master sends an 8-bit register pointer.
5. The slave acknowledges the register pointer.
6. The master sends a data byte.
7. The slave acknowledges the data byte. The next rising edge on SDA loads the data byte into its target register and the data becomes active.
8. Steps 5 to 7 are repeated as many times as the master requires.

The master sends a STOP condition. During the rising edge of the stop related SDA edge, the data byte that was previously written is loaded into the target register and becomes active.

Reading from a Single Register

I²C master device reads one byte of data to the MAX77801. This protocol is the same as SMBus specification's read byte protocol.

The read byte protocol is as follows:

1. The master sends a START command.
2. The master sends the 7-bit slave address followed by a write bit ($R/\bar{W} = 0$).
3. The addressed slave asserts an ACKNOWLEDGE by pulling SDA low.
4. The master sends an 8-bit register pointer.
5. The slave acknowledges the register pointer.
6. The master sends a REPEATED START command.
7. The master sends the 7-bit slave address followed by a read bit ($R/\bar{W} = 1$).
8. The addressed slave asserts an ACKNOWLEDGE by pulling SDA low.
9. The addressed slave places 8 bits of data on the bus from the location specified by the register pointer.
10. The master issues a NOT-ACKNOWLEDGE.
11. The master sends a STOP condition or a REPEATED START condition. Issuing a STOP ensures that the bus input filters are set for 1MHz or slower operation. Issuing a REPEATED START leaves the bus input filters in their current state.

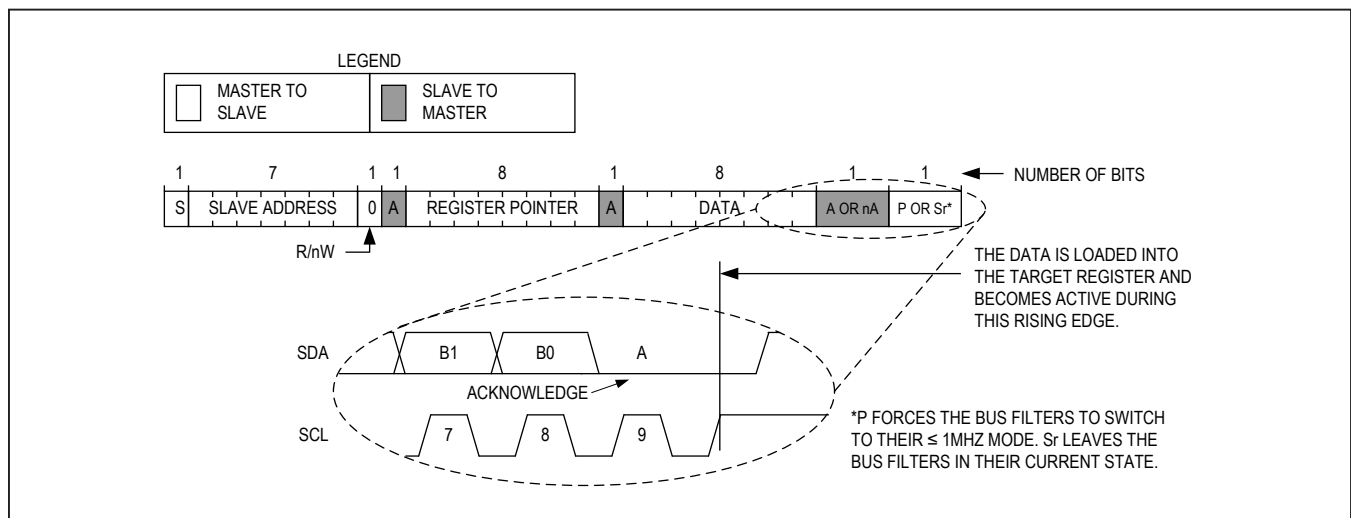

Figure 12. Writing to Multiple Registers with Multiple Byte Register-Data Pairs Protocol

Every time the MAX77801 receives a STOP, its register pointer is set to 0x00. If reading register 0x00 after a STOP has been issued, steps 1 to 6 in the above algorithm can be skipped.

Reading from a Sequential Register

Figure 13 shows the protocol for reading from sequential registers. This protocol is similar to the read byte protocol except the master issues an ACKNOWLEDGE to signal the slave that it wants more data. When the master has all the data it requires, it issues a NOT ACKNOWLEDGE and a STOP to end the transmission.

The continuous read from sequential registers protocol is as follows:

1. The master sends a START command.
2. The master sends the 7-bit slave address followed by a write bit ($R/\bar{W} = 0$).
3. The addressed slave asserts an ACKNOWLEDGE by pulling SDA low.
4. The master sends an 8-bit register pointer.
5. The slave acknowledges the register pointer.
6. The master sends a REPEATED START command.

7. The master sends the 7-bit slave address followed by a read bit ($R/\bar{W} = 1$).
8. The addressed slave asserts an ACKNOWLEDGE by pulling SDA low.
9. The addressed slave places 8-bits of data on the bus from the location specified by the register pointer.
10. The master issues an ACKNOWLEDGE signaling the slave that it wishes to receive more data.
11. Steps 9 to 10 are repeated as many times as the master requires. Following the last byte of data, the master must issue a NOT ACKNOWLEDGE to signal that it wishes to stop receiving data.
12. The master sends a STOP condition or a REPEATED START condition. Issuing a STOP ensures that the bus input filters are set for 1MHz or slower operation. Issuing a REPEATED START leaves the bus input filters in their current state.

Every time the MAX77801 receives a STOP, its register pointer is set to 0x00. If reading register 0x00 after a STOP has been issued, steps 1 to 6 in the above algorithm can be skipped.

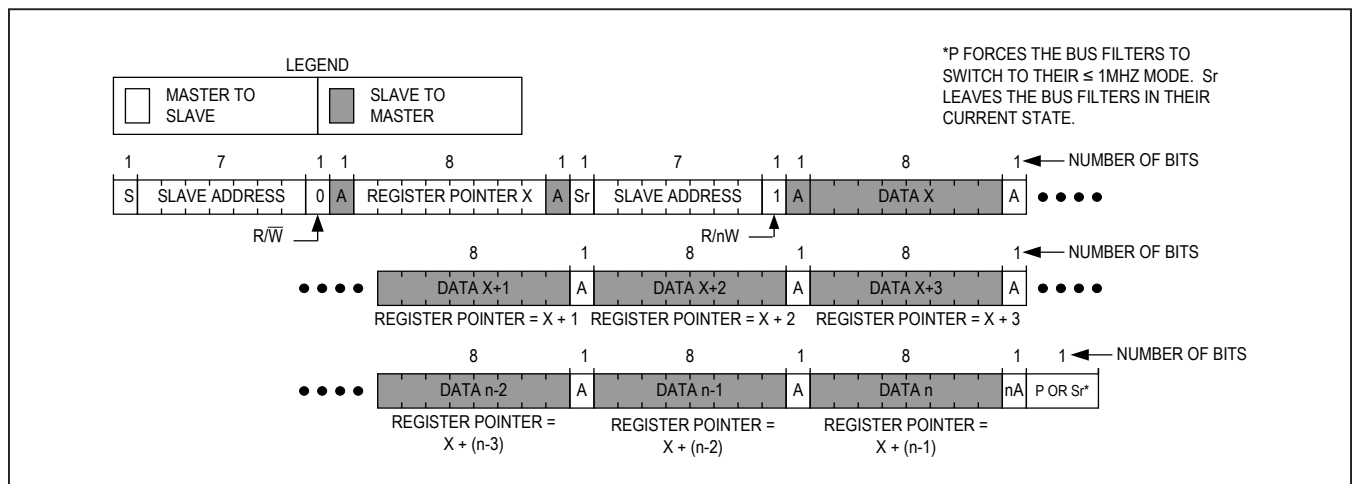

Figure 13. Reading Continuously from Sequential Registers X to N

Engaging HS Mode for Operation Up to 3.4MHz

The figure below shows the protocol for engaging HS mode operation. HS mode operation allows for a bus operating speed up to 3.4MHz.

The engaging HS mode protocol is as follows:

1. Begin the protocol while operating at a bus speed of 1MHz or lower
2. The master sends a START command.
3. The master sends the 8-bit master code of 00001xxx where xxxb are don't care bits.
4. The addressed slave issues a NOTACKNOWLEDGE.

5. The master can now increase its bus speed up to 3.4MHz and issue any read/write operation.

The master may continue to issue high-speed read/write operations until a STOP is issued. Issuing a STOP (P) ensures that the bus input filters are set for 1MHz or slower operation. After a STOP has been issued, steps 1 to 6 in the above algorithm can be skipped.

Registers

Register Reset Conditions

- Type O: Registers are reset when $V_{SYS} < V = low$

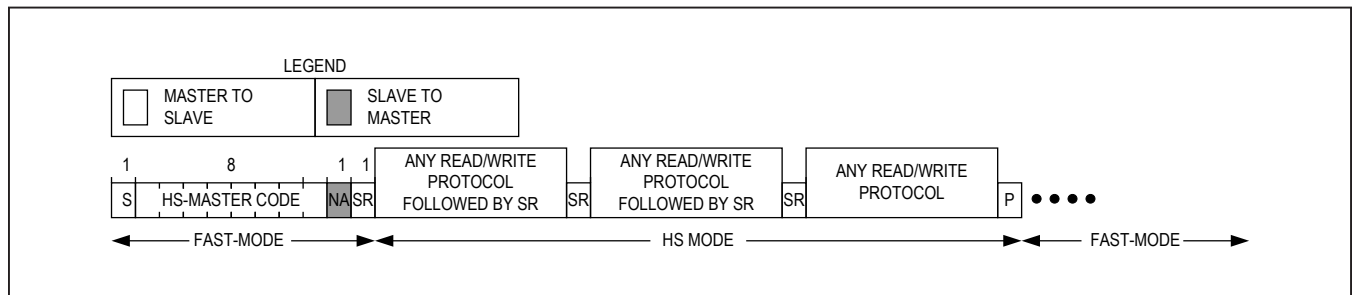

Figure 14. Engaging HS Mode

Register Map

I2C Slave Address (W/R): 0x30/0x31 (default)

ADDRESS	REGISTER NAME	RESET TYPE	R/W	BIT 7	BIT 6	BIT 5	BIT 4	BIT 3	BIT 2	BIT 1	BIT 0	RESET VALUE	
0x00	DEVICE_ID	Type0	R	RESERVED	VERSION[3:0]			CHIP_REV[2:0]					—
0x01	STATUS	Type0	R	RESERVED	RESERVED	RESERVED	RESERVED	TSHDN	BB_POK _n	BB_OVP	BB_OCP	—	
0x02	CONFIG1	Type0	R/W	RESERVED	RESERVED	BB_RU_SR	BB_RD_SR	BB_OVP_TH[1:0]	BB_AD	RESERVED	BB_FPWM	0x0E	
0x03	CONFIG2	Type0	R/W	RESERVED	BB_EN	EN_PD	POK_POL	RESERVED	RESERVED	RESERVED	RESERVED	0x70	
0x04	VOUT_DVS_L	Type0	R/W	RESERVED	VOUT_DVS_L[6:0]							0x38	
0x05	VOUT_DVS_H	Type0	R/W	RESERVED	VOUT_DVS_H[6:0]							0x40	
0x09–0xFF	RESERVED												

DEVICE_ID

Device ID Register

ADDRESS	MODE		TYPE: O	RESET VALUE: N/A
0x00	R			
BIT	NAME	POR	DESCRIPTION	
7	RESERVED	0		
6:3	VERSION[3:0]	—	Version 0000b: Plain 0001b: -1Z 0010b: -2Z	
2:0	CHIP_REV[2:0]	—	Chip revision history 001b: PASS1 010b: PASS2 011b: PASS3 and so on	

STATUS

Status Register

ADDRESS	MODE		TYPE: O	RESET VALUE: N/A
0x01	R			
BIT	NAME	POR	DESCRIPTION	
7:4	RESERVED	—		
3	TSHDN	—	0: Junction Temperature (T _{JCT}) ≤ 165°C 1: Junction Temperature (T _{JCT}) > 165°C	
2	BB_POK _n	—	Buck-boost $\overline{\text{POK}}$ Status	
1	BB_OVP	—	Buck-boost OVP Status	
0	BB_OCP	—	Buck-boost OCP Status	

CONFIG1

Configuration Register1

ADDRESS	MODE		TYPE: O	RESET VALUE: 0x0E
0x02	R/W			
BIT	NAME	POR	DESCRIPTION	
7:6	RESERVED	00		
5	BB_RU_SR	0	Rising Ramp-Rate Control 0: 12.5mV/μs 1: 25mV/μs	
4	BB_RD_SR	0	Ramp-Down Slew Rate Control 0: 3.125mV/μs 1: 6.25mV/μs	
3:2	BB_OVP_TH[1:0]	11	Output OVP Threshold 00b: No OVP 01b: 110% of VOUT 10b: 115% of VOUT 11b: 120% of VOUT	
1	BB_AD	1	Output Active Discharge 0: Disable Active Discharge 1: Enable Active Discharge	
0	BB_FPWM	0	Forced PWM Enable 0: SKIP Mode 1: Forced PWM	

CONFIG2

Configuration Register2

ADDRESS	MODE		TYPE: O	RESET VALUE: 0x70
0x03	R/W			
BIT	NAME	POR	DESCRIPTION	
7	RESERVED	0		
6	BB_EN	1	0: Disable buck-boost output 1: Enable buck-boost output	
5	EN_PD	1	EN Input Pulldown Resistor Enable Setting 0: Disable 1: Enable	
4	POK_POL	1	0: Active low 1: Active high	
3:0	RESERVED	0000		

VOUT_DVS_L

Output Voltage Setting Register when DVS = low

ADDRESS	MODE		TYPE: O	RESET VALUE: 0x38			
0x04	R/W						
BIT	NAME	POR	DESCRIPTION				
7	RESERVED	0					
6:0	VOUT_DVS_L[6:0]	011 1000	Buck-Boost Output Voltage				
			0x00 = 2.6000V	0x20 = 3.0000V	0x40 = 3.4000V	0x60 = 3.8000V	
			0x01 = 2.6125V	0x21 = 3.0125V	0x41 = 3.4125V	0x61 = 3.8125V	
			0x02 = 2.6250V	0x22 = 3.0250V	0x42 = 3.4250V	0x62 = 3.8250V	
			0x03 = 2.6375V	0x23 = 3.0375V	0x43 = 3.4375V	0x63 = 3.8375V	
			0x04 = 2.6500V	0x24 = 3.0500V	0x44 = 3.4500V	0x64 = 3.8500V	
			0x05 = 2.6625V	0x25 = 3.0625V	0x45 = 3.4625V	0x65 = 3.8625V	
			0x06 = 2.6750V	0x26 = 3.0750V	0x46 = 3.4750V	0x66 = 3.8750V	
			0x07 = 2.6875V	0x27 = 3.0875V	0x47 = 3.4875V	0x67 = 3.8875V	
			0x08 = 2.7000V	0x28 = 3.1000V	0x48 = 3.5000V	0x68 = 3.9000V	
			0x09 = 2.7125V	0x29 = 3.1125V	0x49 = 3.5125V	0x69 = 3.9125V	
			0x0A = 2.7250V	0x2A = 3.1250V	0x4A = 3.5250V	0x6A = 3.9250V	
			0x0B = 2.7375V	0x2B = 3.1375V	0x4B = 3.5375V	0x6B = 3.9375V	
			0x0C = 2.7500V	0x2C = 3.1500V	0x4C = 3.5500V	0x6C = 3.9500V	
			0x0D = 2.7625V	0x2D = 3.1625V	0x4D = 3.5625V	0x6D = 3.9625V	
			0x0E = 2.7750V	0x2E = 3.1750V	0x4E = 3.5750V	0x6E = 3.9750V	
			0x0F = 2.7875V	0x2F = 3.1875V	0x4F = 3.5875V	0x6F = 3.9875V	
			0x10 = 2.8000V	0x30 = 3.2000V	0x50 = 3.6000V	0x70 = 4.0000V	
			0x11 = 2.8125V	0x31 = 3.2125V	0x51 = 3.6125V	0x71 = 4.0125V	
			0x12 = 2.8250V	0x32 = 3.2250V	0x52 = 3.6250V	0x72 = 4.0250V	
0x13 = 2.8375V	0x33 = 3.2375V	0x53 = 3.6375V	0x73 = 4.0375V				
0x14 = 2.8500V	0x34 = 3.2500V	0x54 = 3.6500V	0x74 = 4.0500V				
0x15 = 2.8625V	0x35 = 3.2625V	0x55 = 3.6625V	0x75 = 4.0625V				
0x16 = 2.8750V	0x36 = 3.2750V	0x56 = 3.6750V	0x76 = 4.0750V				
0x17 = 2.8875V	0x37 = 3.2875V	0x57 = 3.6875V	0x77 = 4.0875V				
0x18 = 2.9000V	0x38 = 3.3000V	0x58 = 3.7000V	0x78 = 4.1000V				
0x19 = 2.9125V	0x39 = 3.3125V	0x59 = 3.7125V	0x79 = 4.1125V				
0x1A = 2.9250V	0x3A = 3.3250V	0x5A = 3.7250V	0x7A = 4.1250V				
0x1B = 2.9375V	0x3B = 3.3375V	0x5B = 3.7375V	0x7B = 4.1375V				
0x1C = 2.9500V	0x3C = 3.3500V	0x5C = 3.7500V	0x7C = 4.1500V				
0x1D = 2.9625V	0x3D = 3.3625V	0x5D = 3.7625V	0x7D = 4.1625V				
0x1E = 2.9750V	0x3E = 3.3750V	0x5E = 3.7750V	0x7E = 4.1750V				
0x1F = 2.9875V	0x3F = 3.3875V	0x5F = 3.7875V	0x7F = 4.1875V				

VOUT_DVS_H

Output Voltage Setting Register when DVS = high

ADDRESS	MODE		TYPE: O	RESET VALUE: 0x40			
0x05	R/W						
BIT	NAME	POR	DESCRIPTION				
7	RESERVED	0					
6:0	VOUT_DVS_H[6:0]	011 1000	Buck-Boost Output Voltage				
			0x00 = 2.6000V	0x20 = 3.0000V	0x40 = 3.4000V	0x60 = 3.8000V	
			0x01 = 2.6125V	0x21 = 3.0125V	0x41 = 3.4125V	0x61 = 3.8125V	
			0x02 = 2.6250V	0x22 = 3.0250V	0x42 = 3.4250V	0x62 = 3.8250V	
			0x03 = 2.6375V	0x23 = 3.0375V	0x43 = 3.4375V	0x63 = 3.8375V	
			0x04 = 2.6500V	0x24 = 3.0500V	0x44 = 3.4500V	0x64 = 3.8500V	
			0x05 = 2.6625V	0x25 = 3.0625V	0x45 = 3.4625V	0x65 = 3.8625V	
			0x06 = 2.6750V	0x26 = 3.0750V	0x46 = 3.4750V	0x66 = 3.8750V	
			0x07 = 2.6875V	0x27 = 3.0875V	0x47 = 3.4875V	0x67 = 3.8875V	
			0x08 = 2.7000V	0x28 = 3.1000V	0x48 = 3.5000V	0x68 = 3.9000V	
			0x09 = 2.7125V	0x29 = 3.1125V	0x49 = 3.5125V	0x69 = 3.9125V	
			0x0A = 2.7250V	0x2A = 3.1250V	0x4A = 3.5250V	0x6A = 3.9250V	
			0x0B = 2.7375V	0x2B = 3.1375V	0x4B = 3.5375V	0x6B = 3.9375V	
			0x0C = 2.7500V	0x2C = 3.1500V	0x4C = 3.5500V	0x6C = 3.9500V	
			0x0D = 2.7625V	0x2D = 3.1625V	0x4D = 3.5625V	0x6D = 3.9625V	
			0x0E = 2.7750V	0x2E = 3.1750V	0x4E = 3.5750V	0x6E = 3.9750V	
			0x0F = 2.7875V	0x2F = 3.1875V	0x4F = 3.5875V	0x6F = 3.9875V	
			0x10 = 2.8000V	0x30 = 3.2000V	0x50 = 3.6000V	0x70 = 4.0000V	
			0x11 = 2.8125V	0x31 = 3.2125V	0x51 = 3.6125V	0x71 = 4.0125V	
			0x12 = 2.8250V	0x32 = 3.2250V	0x52 = 3.6250V	0x72 = 4.0250V	
0x13 = 2.8375V	0x33 = 3.2375V	0x53 = 3.6375V	0x73 = 4.0375V				
0x14 = 2.8500V	0x34 = 3.2500V	0x54 = 3.6500V	0x74 = 4.0500V				
0x15 = 2.8625V	0x35 = 3.2625V	0x55 = 3.6625V	0x75 = 4.0625V				
0x16 = 2.8750V	0x36 = 3.2750V	0x56 = 3.6750V	0x76 = 4.0750V				
0x17 = 2.8875V	0x37 = 3.2875V	0x57 = 3.6875V	0x77 = 4.0875V				
0x18 = 2.9000V	0x38 = 3.3000V	0x58 = 3.7000V	0x78 = 4.1000V				
0x19 = 2.9125V	0x39 = 3.3125V	0x59 = 3.7125V	0x79 = 4.1125V				
0x1A = 2.9250V	0x3A = 3.3250V	0x5A = 3.7250V	0x7A = 4.1250V				
0x1B = 2.9375V	0x3B = 3.3375V	0x5B = 3.7375V	0x7B = 4.1375V				
0x1C = 2.9500V	0x3C = 3.3500V	0x5C = 3.7500V	0x7C = 4.1500V				
0x1D = 2.9625V	0x3D = 3.3625V	0x5D = 3.7625V	0x7D = 4.1625V				
0x1E = 2.9750V	0x3E = 3.3750V	0x5E = 3.7750V	0x7E = 4.1750V				
0x1F = 2.9875V	0x3F = 3.3875V	0x5F = 3.7875V	0x7F = 4.1875V				

Ordering Information

PART	TEMP RANGE	PIN-PACKAGE
MAX77801EWP+T	-40°C to 85°C	20 WLP (5 x 4) 0.4mm Pitch

+Denotes a lead(Pb)-free/RoHS-compliant package.

T = Tape and reel.

Chip Information

PROCESS: S18B

Package Information

For the latest package outline information and land patterns (footprints), go to www.maximintegrated.com/packages. Note that a "+", "#", or "-" in the package code indicates RoHS status only. Package drawings may show a different suffix character, but the drawing pertains to the package regardless of RoHS status.

PACKAGE TYPE	PACKAGE CODE	OUTLINE NO.	LAND PATTERN NO.
20 WLP	W201F2+1	21-0771	Refer to Application Note 1891

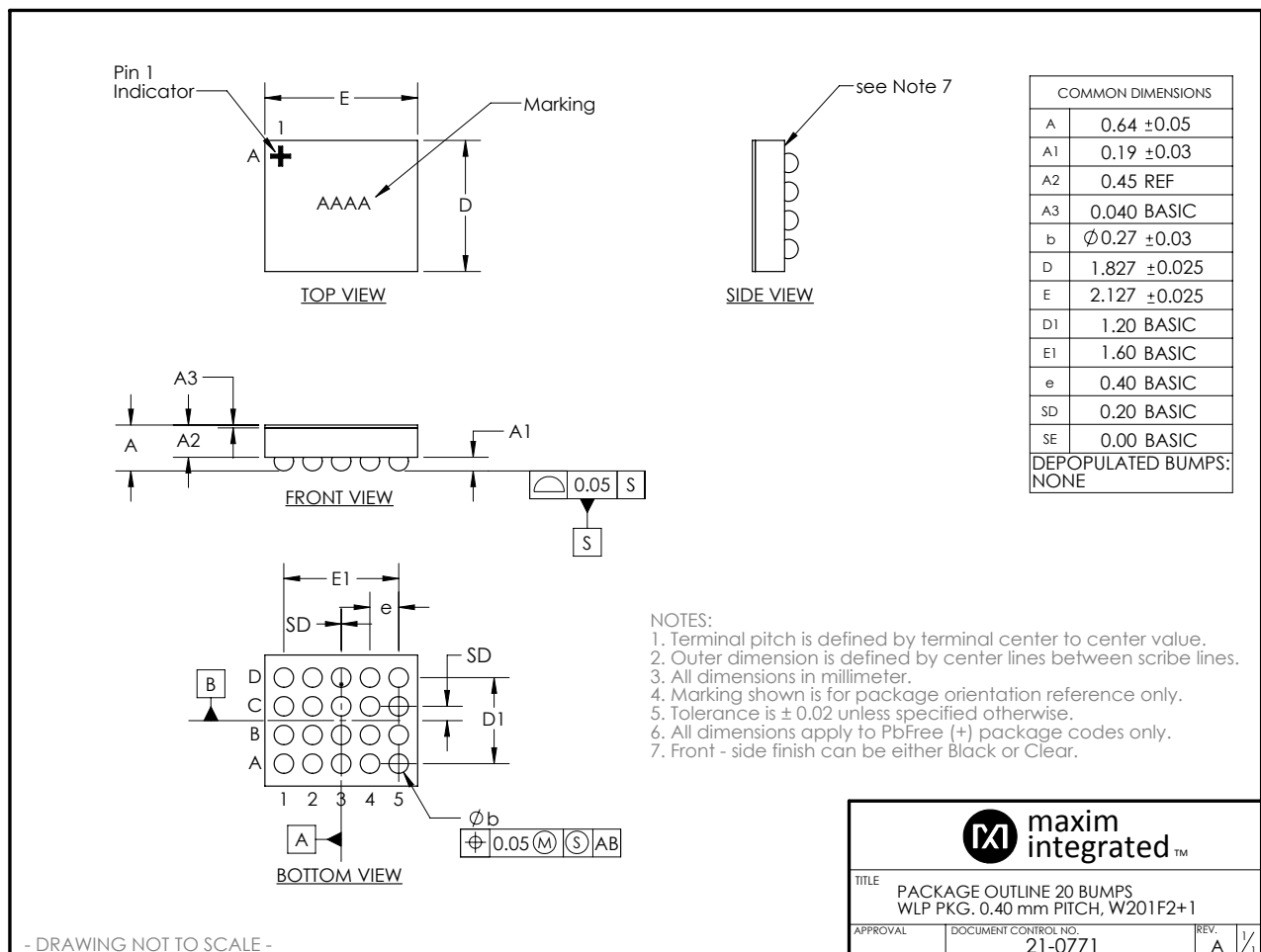

Revision History

REVISION NUMBER	REVISION DATE	DESCRIPTION	PAGES CHANGED
0	2/15	Initial release	—

Maxim Integrated cannot assume responsibility for use of any circuitry other than circuitry entirely embodied in a Maxim Integrated product. No circuit patent licenses are implied. Maxim Integrated reserves the right to change the circuitry and specifications without notice at any time. The parametric values (min and max limits) shown in the Electrical Characteristics table are guaranteed. Other parametric values quoted in this data sheet are provided for guidance.

Компания «Океан Электроники» предлагает заключение долгосрочных отношений при поставках импортных электронных компонентов на взаимовыгодных условиях!

Наши преимущества:

- Поставка оригинальных импортных электронных компонентов напрямую с производств Америки, Европы и Азии, а так же с крупнейших складов мира;
- Широкая линейка поставок активных и пассивных импортных электронных компонентов (более 30 млн. наименований);
- Поставка сложных, дефицитных, либо снятых с производства позиций;
- Оперативные сроки поставки под заказ (от 5 рабочих дней);
- Экспресс доставка в любую точку России;
- Помощь Конструкторского Отдела и консультации квалифицированных инженеров;
- Техническая поддержка проекта, помощь в подборе аналогов, поставка прототипов;
- Поставка электронных компонентов под контролем ВП;
- Система менеджмента качества сертифицирована по Международному стандарту ISO 9001;
- При необходимости вся продукция военного и аэрокосмического назначения проходит испытания и сертификацию в лаборатории (по согласованию с заказчиком);
- Поставка специализированных компонентов военного и аэрокосмического уровня качества (Xilinx, Altera, Analog Devices, Intersil, Interpoint, Microsemi, Actel, Aeroflex, Peregrine, VPT, Syfer, Eurofarad, Texas Instruments, MS Kennedy, Miteq, Cobham, E2V, MA-COM, Hittite, Mini-Circuits, General Dynamics и др.);

Компания «Океан Электроники» является официальным дистрибьютором и эксклюзивным представителем в России одного из крупнейших производителей разъемов военного и аэрокосмического назначения «JONHON», а так же официальным дистрибьютором и эксклюзивным представителем в России производителя высокотехнологичных и надежных решений для передачи СВЧ сигналов «FORSTAR».



JONHON

«JONHON» (основан в 1970 г.)

Разъемы специального, военного и аэрокосмического назначения:

(Применяются в военной, авиационной, аэрокосмической, морской, железнодорожной, горно- и нефтедобывающей отраслях промышленности)

«FORSTAR» (основан в 1998 г.)

ВЧ соединители, коаксиальные кабели,
кабельные сборки и микроволновые компоненты:

(Применяются в телекоммуникациях гражданского и специального назначения, в средствах связи, РЛС, а так же военной, авиационной и аэрокосмической отраслях промышленности).



Телефон: 8 (812) 309-75-97 (многоканальный)

Факс: 8 (812) 320-03-32

Электронная почта: ocean@oceanchips.ru

Web: <http://oceanchips.ru/>

Адрес: 198099, г. Санкт-Петербург, ул. Калинина, д. 2, корп. 4, лит. А