

IRAUDAMP8

120W x 4 Channel Class D Audio Power Amplifier Using the IRS2093M and IRF6665

By

Jun Honda, Yasushi Nishimura and Liwei Zheng



CAUTION:

International Rectifier suggests the following guidelines for safe operation and handling of IRAUDAMP8 Demo board;

- Always wear safety glasses whenever operating Demo Board
- Avoid personal contact with exposed metal surfaces when operating Demo Board
- Turn off Demo Board when placing or removing measurement probes

TABLE OF CONTENTS	PAGE
INTRODUCTION	3
SPECIFICATIONS	3
CONNECTION SETUP	5
CONNECTOR DESCRIPTION	5
TEST PROCEDURES	6
PERFORMANCE AND TEST GRAPHS	7
CLIPPING CHARACTERISTICS	10
EFFICIENCY	11
THERMAL CONSIDERATIONS	11
THERMAL INTERFACE MATERIAL'S PRESSURE CONTROL.....	12
POWER SUPPLY REJECTION RATIO (PSRR)	14
SHORT CIRCUIT PROTECTION RESPONSE	15
IRAUDAMP8 OVERVIEW	16
FUNCTIONAL DESCRIPTIONS	18
IRS2093 GATE DRIVER IC.....	18
SELF-OSCILLATING FREQUENCY.....	19
ADJUSTMENTS OF SELF-OSCILLATING FREQUENCY.....	19
SELECTABLE DEAD-TIME.....	20
PROTECTION SYSTEM OVERVIEW	21
CLICK AND POP NOISE REDUCTION	23
BUS PUMPING	23
INPUT SIGNAL AND GAIN SETTING	25
GAIN SETTING	25
SCHEMATIC	26
IRAUDAMP8 FABRICATION MATERIALS	27
IRAUDAMP8 HARDWARE	30
IRAUDAMP8 PCB SPECIFICATIONS	31
REVISION CHANGES DESCRIPTIONS	34

Introduction

The IRAUDAMP8 Demo board is a reference design which uses only one IC (IRS2093M) to derive appropriate input signals, amplify the audio input, and achieve a four-channel 120 W/ch (4Ω) half-bridge Class D audio power amplifier. The reference design demonstrates how to use the IRS2093M Class D audio controller and gate driver IC, implement protection circuits, and design an optimum PCB layout using IRF6665 DirectFET MOSFETs. The reference design contains all the required housekeeping power supplies for ease of use. The four-channel design is scalable, for power and number of channels.

Applications

- AV receivers
- Home theater systems
- Mini component stereos
- Powered speakers
- Sub-woofers
- Musical Instrument amplifiers
- Automotive after market amplifiers

Features

Output Power:	120W x 4 channels,
Residual Noise:	200 μ V, IHF-A weighted, AES-17 filter
Distortion:	0.012% THD+N @ 60W, 4 Ω
Efficiency:	90% @ 120W, 4 Ω , single-channel driven, Class D stage
Multiple Protection Features:	Over-current protection (OCP), high side and low side Over-voltage protection (OVP), Under-voltage protection (UVP), high side and low side Over-temperature protection (OTP)
PWM Modulator:	Self-oscillating half-bridge topology with optional clock synchronization

Specifications

General Test Conditions (unless otherwise noted)		Notes / Conditions
Supply Voltages	± 35 V	
Load Impedance	4 Ω	
Self-Oscillating Frequency	400kHz	No input signal, Adjustable
Gain Setting	26.5dB	1Vrms input yields rated power

Electrical Data	Typical	Notes / Conditions
IR Devices Used	IRS2093M Audio Controller and Gate-Driver, IRF6665 DirectFET MOSFETs	
Modulator	Self-oscillating, second order sigma-delta modulation, analog input	
Power Supply Range	± 25 V to ± 35 V	Bipolar power supply
Output Power CH1-4: (1% THD+N)	120W	1kHz
Output Power CH1-4: (10% THD+N)	170W	1kHz
Rated Load Impedance	8-4 Ω	Resistive load

Standby Supply Current	±100mA	No input signal
Total Idle Power Consumption	7W	No input signal
Channel Efficiency	90%	Single-channel driven, 120W, Class D stage

Audio Performance	*Before Demodulator	Class D Output	Notes / Conditions
THD+N, 1W	0.015%	0.015%	
THD+N, 10W	0.006%	0.008%	1kHz, Single-channel driven
THD+N, 60W	0.005%	0.012%	
THD+N, 100W	0.015%	0.02%	
Dynamic Range	101dB	101dB	A-weighted, AES-17 filter, Single-channel operation
Residual Noise, 22Hz - 20kHzAES17	200µV	200µV	Self-oscillating – 400kHz
Damping Factor	2000	48	1kHz, relative to 4Ω load
Channel Separation	85dB	78dB	100Hz
	85dB	77dB	1kHz
	75dB	70dB	10kHz
Frequency Response : 20Hz-20kHz : 20Hz-35kHz	N/A	±1dB	1W, 4Ω - 8Ω Load
		±3dB	

Thermal Performance	Typical	Notes / Conditions
Idling	T _C =30°C T _{PCB} =42°C	No signal input, T _A =25°C
4ch x 15W (1/8 rated power)	T _C =54°C T _{PCB} =71°C	Continuous, T _A =25°C
4ch x 120W (Rated power)	T _C =80°C T _{PCB} =106°C	At OTP shutdown @ 150 sec, T _A =25°C

Physical Specifications

Dimensions	3.94"(L) x 2.83"(W) x 0.85"(H) 100 mm (L) x 72 mm (W) x 21.5 mm(H)
Weight	0.140kgm

Connection Setup

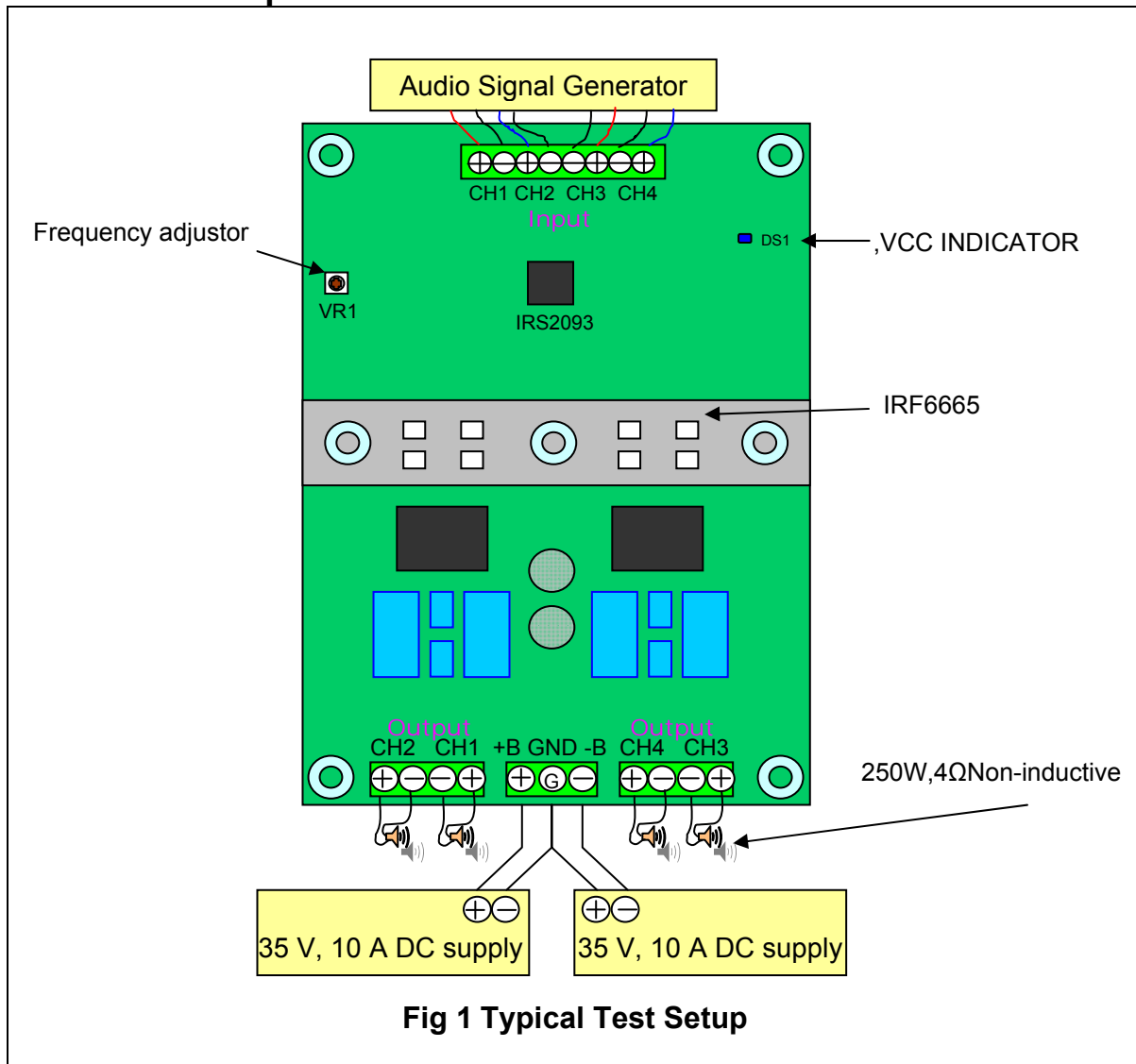

Fig 1 Typical Test Setup

Connector Description

CH1 IN	CN1	Analog input for CH1
CH2 IN	CN1	Analog input for CH2
CH3 IN	CN1	Analog input for CH3
CH4 IN	CN1	Analog input for CH4
SUPPLY	P1	Positive and negative supply (+B / -B)
CH1 OUT	P2	Output for CH1
CH2 OUT	P2	Output for CH2
CH3 OUT	P3	Output for CH3
CH4 OUT	P3	Output for CH4

Test Procedures

Test Setup:

1. Connect 4 Ω -200 W dummy loads to 4 output connectors (P2 and P3 as shown on Fig 1) and an Audio Precision analyzer (AP).
2. Connect the Audio Signal Generator to CN2 for CH1~CH4 respectively (AP).
3. Set up the dual power supply with voltages of $\pm 35V$; current limit to 10A.
4. TURN OFF the dual power supply before connecting to On of the unit under test (UUT).
5. Connect the dual power supply to P1. as shown on Fig 1

Power up:

6. Turn ON the dual power supply. The $\pm B$ supplies must be applied and removed at the same time.
7. The Blue LED should turn ON immediately and stay ON
8. Quiescent current for the positive supply should be 100mA \pm 10mA at +35V.
9. Quiescent current for the negative supply should be 115mA \pm 10mA at -35V.

Switching Frequency test

10. With an Oscilloscope, monitor the switching waveform at test points VS1~VS4. Adjust VR1 to set the self oscillating frequency to 400 kHz \pm 25 kHz.

Functionality Audio Tests:

11. Set the signal generator to 1kHz, 20 mV_{RMS} output.
12. Connect the audio signal generator to CN2(Input of CH1,CH2,CH3,CH4)
13. Sweep the audio signal voltage from 15 mV_{RMS} to 1 V_{RMS}.
14. Monitor the output signals at P2/P3 with an oscilloscope. The waveform must be a non distorted sinusoidal signal.
15. Observe that a 1 V_{RMS} input generates an output voltage of 21.2 V_{RMS}. The ratio, R4A/(R3A), determines the voltage gain of IRAUDAMP8.

Test Setup using Audio Precision (Ap):

16. Use an unbalanced-floating signal from the generator outputs.
17. Use balanced inputs taken across output terminals, P2 and P3.
18. Connect Ap frame ground to GND at terminal P1.
19. Select the AES-17 filter(pull-down menu) for all the testing except frequency response.
20. Use a signal voltage sweep range from 15 mV_{RMS} to 1 V_{RMS}.
21. Run Ap test programs for all subsequent tests as shown in Fig 2- Fig 7below.

Performance and test graphs

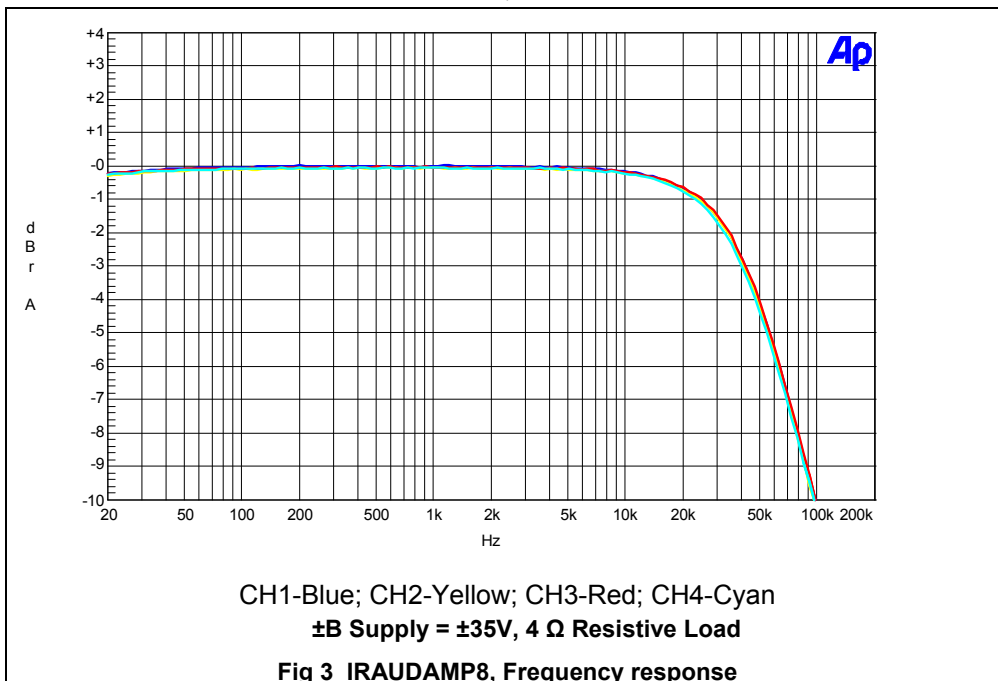
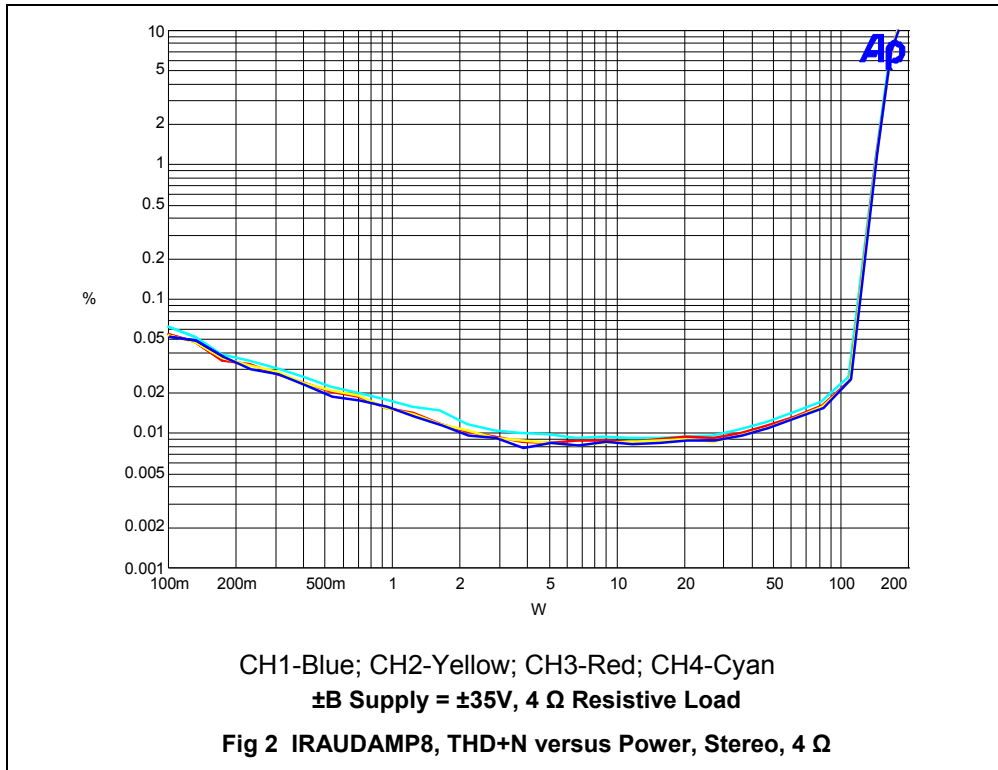

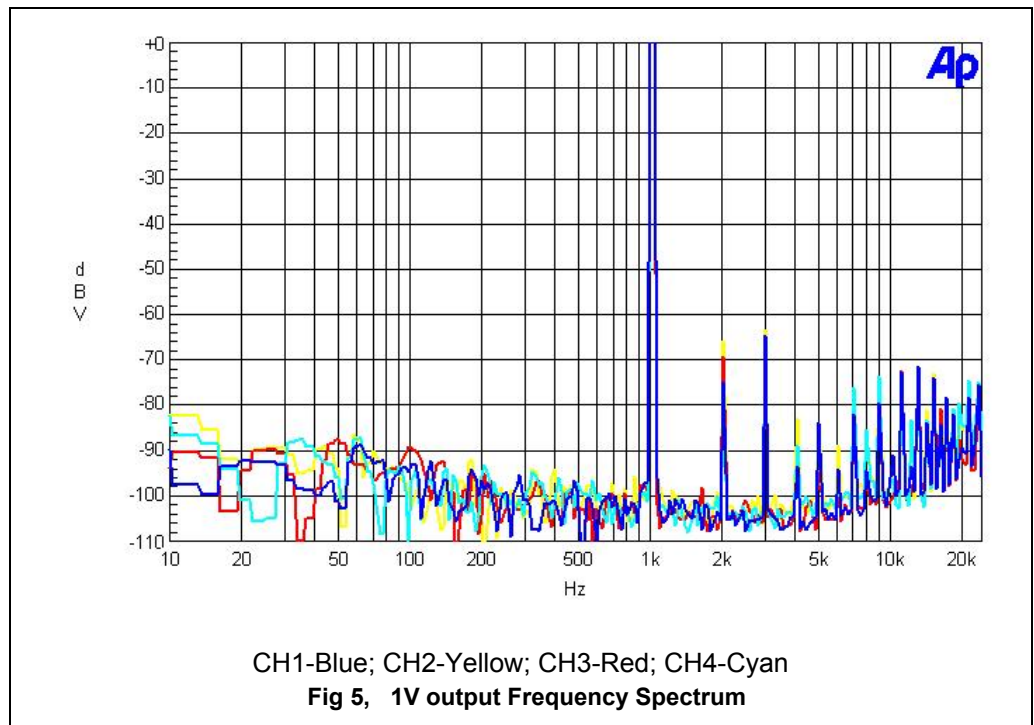
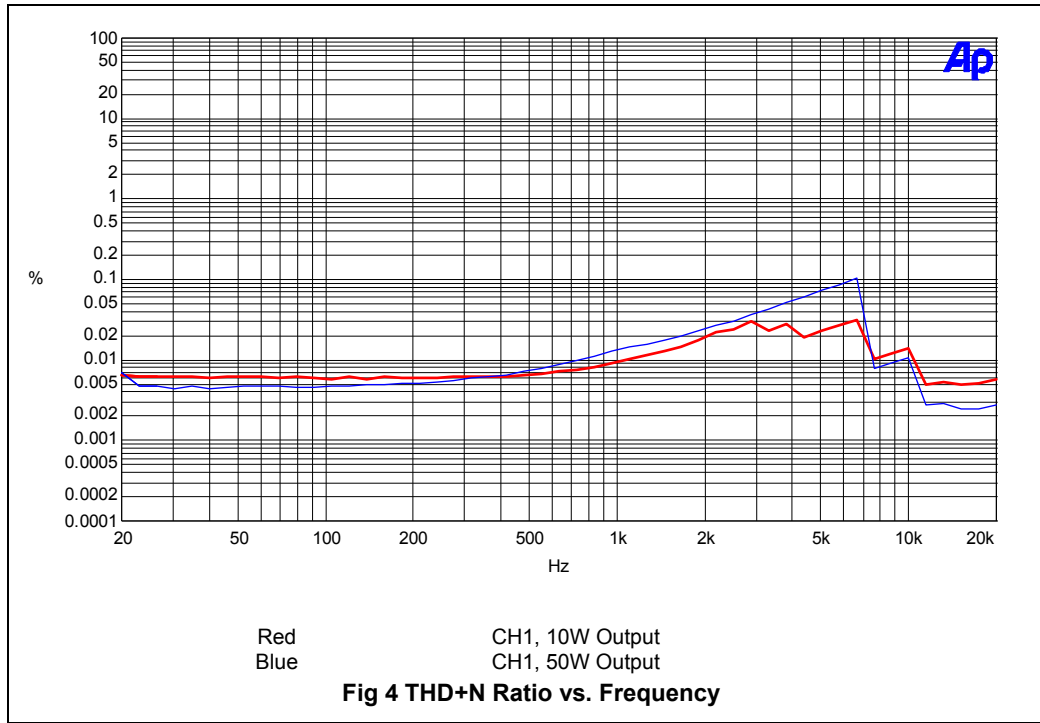

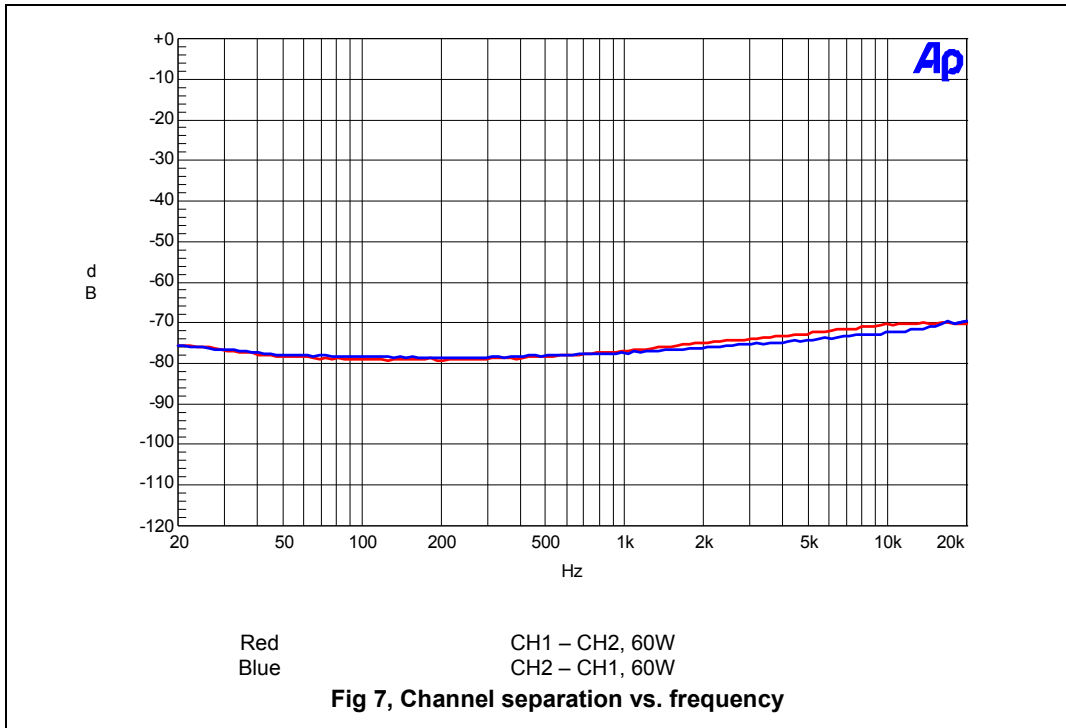
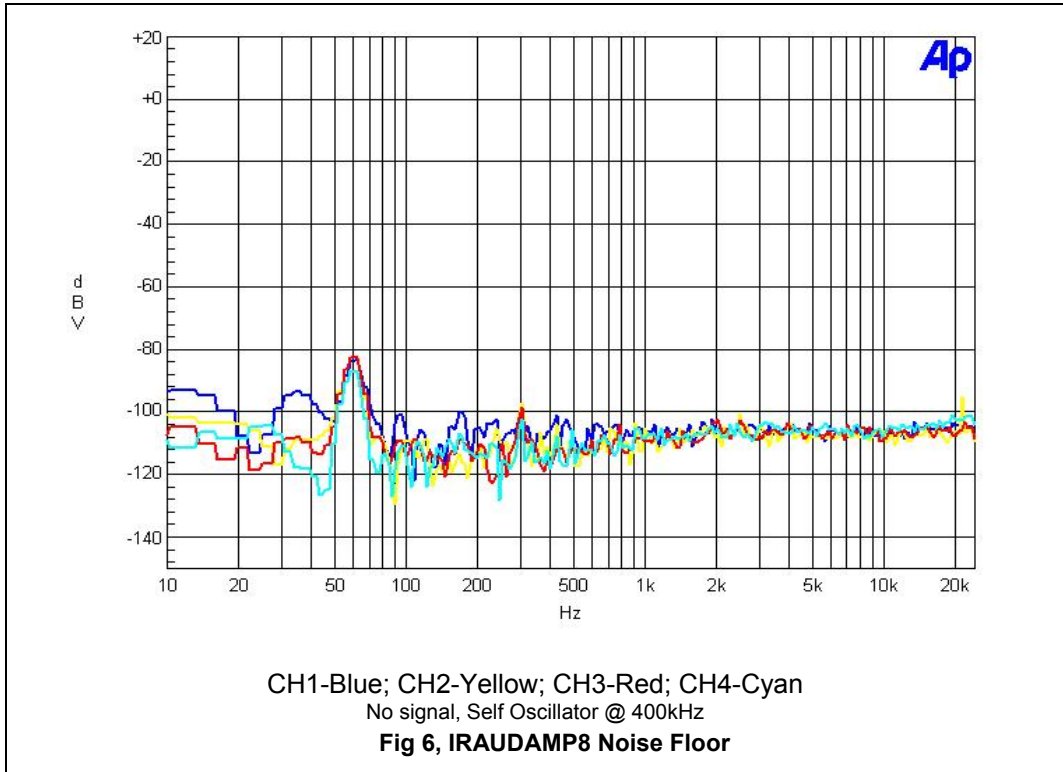

Clipping characteristics

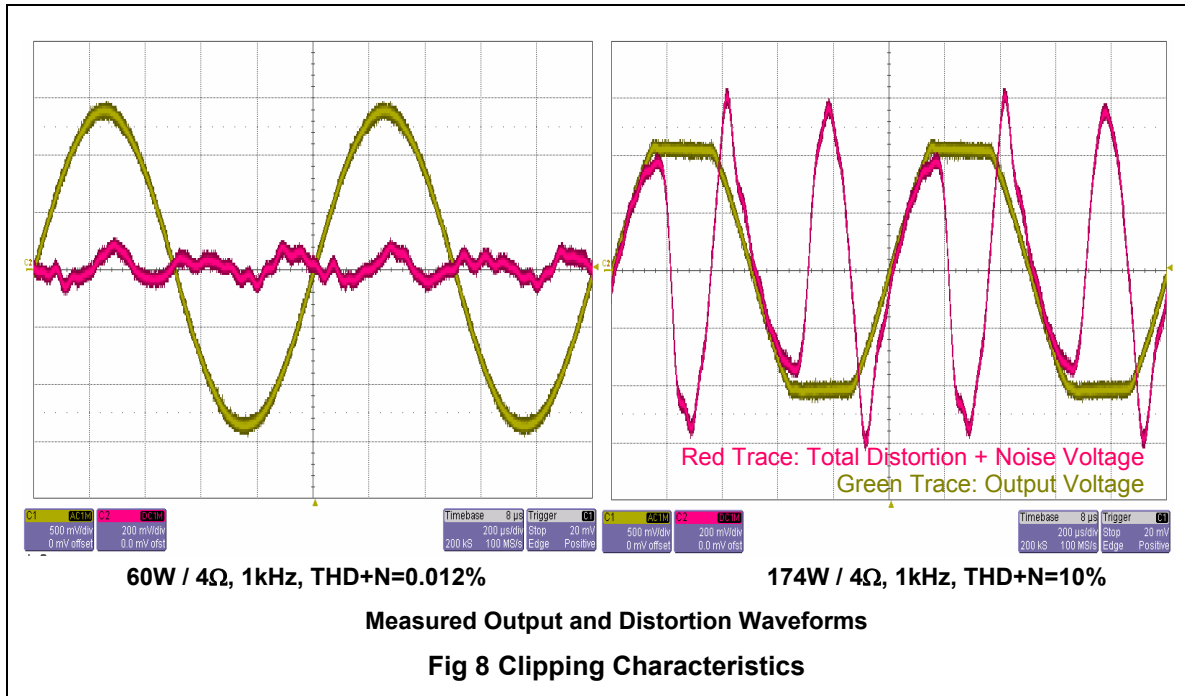

Efficiency

Fig 9 shows efficiency characteristics of the IRAUDAMP8. The high efficiency is achieved by following major factors:

- 1) Low conduction loss due to the DirectFETs offering low $R_{DS(ON)}$
- 2) Low switching loss due to the DirectFETs offering low input capacitance for fast rise and fall times

Secure dead-time provided by the IRS2093, avoiding cross-conduction

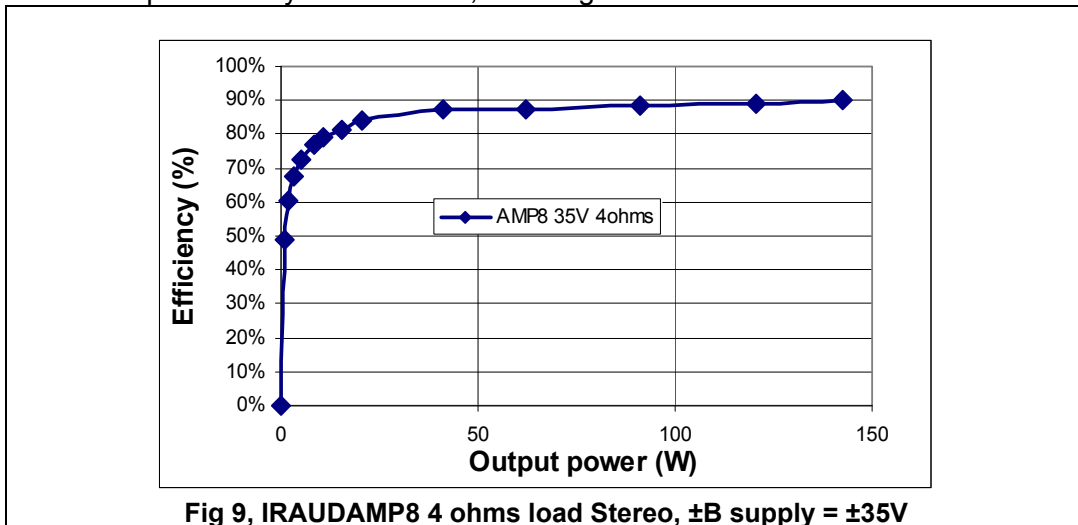

Thermal Considerations

With this high efficiency, the IRAUDAMP8 design can handle one-eighth of the continuous rated power, which is generally considered to be a normal operating condition for safety standards, without additional heatsinks or forced air-cooling.

Thermal Interface Material's Pressure Control

The pressure between DirectFET & TIM (Thermal Interface Material) is controlled by depth of Heat Spreader's groove. Choose TIM which is recommended by [IR](#). (Refer to AN-1035 for more details). TIM's manufacturer thickness, conductivity, & etc. determine pressure requirement. Below shows selection options recommended:

Common Thermal Interface Materials Cost Trades

Mfr.	Material	Type	Thickness (mils)	Pressure Required	Dispense/Apply	Clips/Screws	Can be applied to heat sink?	Mechanical Placement?
Dow Corning	1-4173	1 part heat-cured adhesive	#	Yes	Dispense	Clips	N	Y
Dow Corning	SE 4451	2 part heat-cured adhesive	#	Yes	Dispense	Clips	N	Y
Dow Corning	3-6652	2 part heat-cured adhesive	#	Yes	Dispense	Clips	N	Y
Dow Corning	TP-1500 Pad	Tacky - Phase Change at 52° C	10	>5psi, 20psi typ	Apply	Clips	Y	Y
Bergquist	Gap Pad 3000	conformable filled polymer sheet	15	>10psi	Apply	Clips/Screws	N	Y
Bergquist	Gap Pad 2000	conformable filled polymer sheet	10	>10psi	Apply	Clips/Screws	N	Y
Bergquist	Hi Flow 300	Phase Change at 55°C	2.4	>10psi	Apply	Clips	Y	*
Bergquist	Hi Flow 625	Phase Change at 65°C	5	>10psi	Apply	Clips	Y	*
Bergquist	Hi Flow 818	Phase Change at 65°C	5.5	>10psi	Apply	Clips	Y	*
Bergquist	Sil Pad 800	Conformable silicone elastomer	5	>10 higher better	Apply	Clips/Screws	Y	*
Bergquist	Sil Pad 900	Conformable silicone elastomer	9	>10 higher better	Apply	Clips/Screws	Y	*
Bergquist	Sil Pad A1500	Conformable silicone elastomer	10	10-50psi	Apply	Clips/Screws	Y	*
Bergquist	Sil Pad A2000	Conformable silicone elastomer	10	10-50psi	Apply	Clips/Screws	Y	*
Bergquist	Bond Ply 100	Pressure sensitive adhesive tape	5	>10psi	Apply	Clips	Y	Y
Bergquist	Bond Ply 100	Pressure sensitive adhesive tape	11	>10psi	Apply	Clips	Y	Y
Thermoset (Lord)	Gelease MG-120	Thermal grease/gel	#	5-7lbf	Dispense	Clips	N	Y
Shin Etsu	X-23-7783D	Thermal grease	#	-	Dispense	Clips	N	Y
Shin Etsu	X-23-7762	Thermal grease	#	-	Dispense	Clips	N	Y

Fig 10 TIM Information

Check the TIM's compression deflection with constant rate of strain (example as Fig.11) base on manufacturer's datasheet. According to the stress requirement, find strain range for the TIM. Then, calculate heat spreader groove depth as below:

$$\text{Groove Depth} = \text{DirectFET's Height} + \text{TIM's Thickness} * \text{strain}$$

**DirectFET's height should be measured from PCB to the top of DirectFET after reflow. The average height of IRF6665 is 0.6mm.

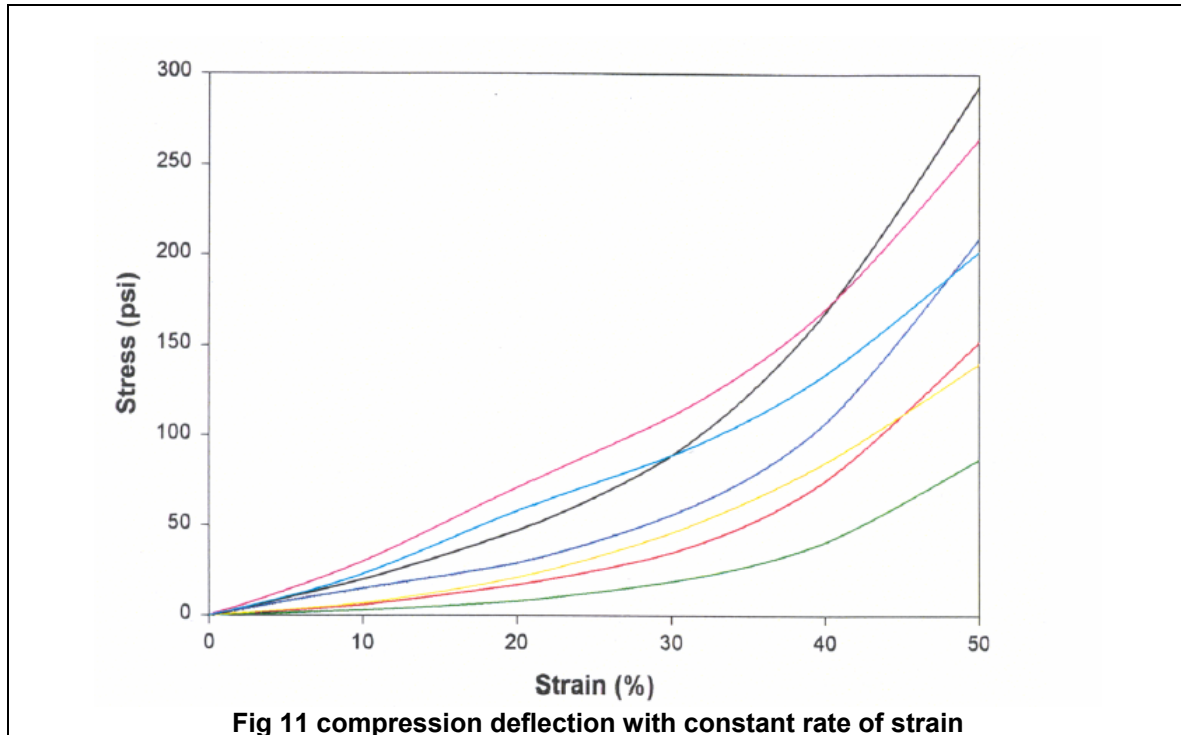

Power Supply Rejection Ratio (PSRR)

The IRAUDAMP8 obtains good power supply rejection ratio of -68 dB at 1kHz shown in Fig 12. With this high PSRR, IRAUDAMP8 accepts any power supply topology when the supply voltages fit between the min and max range.

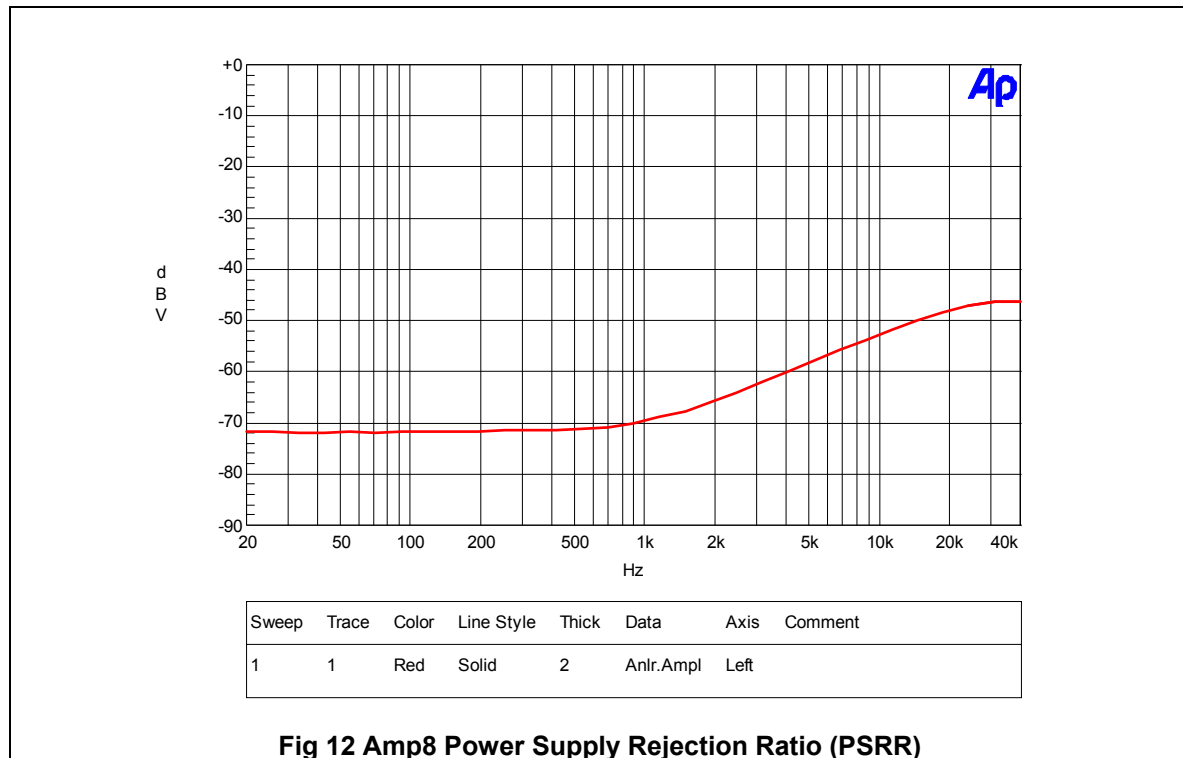

Short Circuit Protection Response

Figs 13-14 show over current protection reaction time of the IRAUDAMP8 in a short circuit event. As soon as the IRS2093 detects an over current condition, it shuts down PWM. After one second, the IRS2093 tries to resume the PWM. If the short circuit persists, the IRS2093 repeats try and fail sequences until the short circuit is removed.

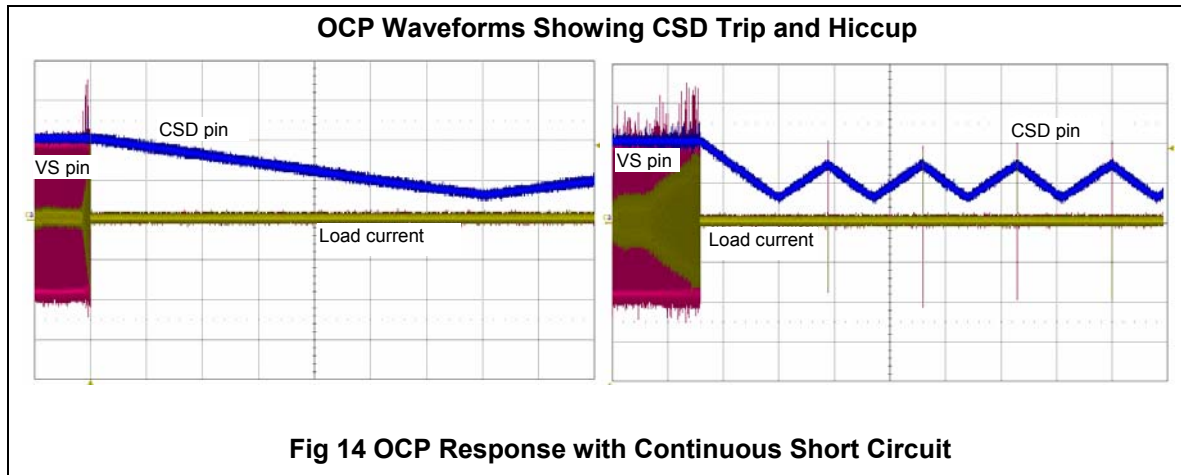
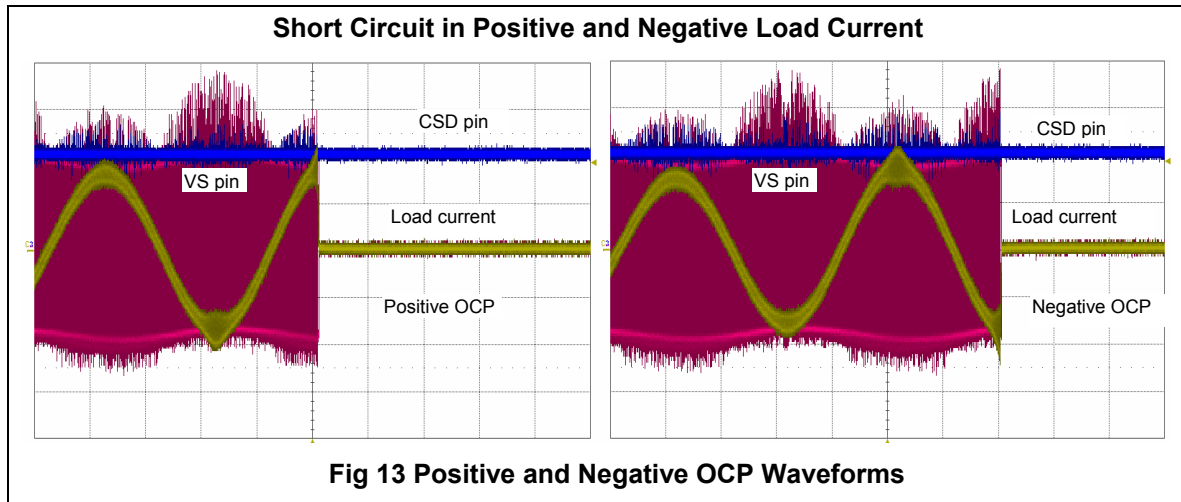

IRAUDAMP8 Overview

The IRAUDAMP8 features a 4CH self-oscillating type PWM modulator for the smallest space, highest performance and robust design. This topology represents an analog version of a second-order sigma-delta modulation having a Class D switching stage inside the loop. The benefit of the sigma-delta modulation, in comparison to the carrier-signal based modulation, is that all the error in the audible frequency range is shifted to the inaudible upper-frequency range by nature of its operation. Also, sigma-delta modulation allows a designer to apply a sufficient amount of error correction.

The IRAUDAMP8 self-oscillating topology consists of following essential functional blocks.

- Front-end integrator
- PWM comparator
- Level shifters
- Gate drivers and MOSFETs
- Output LPF

Integrator

Referring to Fig 15 below, the input operational amplifier of the IRS2093 forms a front-end second-order integrator with R3, C2, C3, and R2. The integrator that receives a rectangular feedback signal from the PWM output via R4 and audio input signal via R3 generates a quadratic carrier signal at the COMP pin. The analog input signal shifts the average value of the quadratic waveform such that the duty cycle varies according to the instantaneous voltage of the analog input signal.

PWM Comparator

The carrier signal at the COMP pin is converted to a PWM signal by an internal comparator that has a threshold at middle point between VAA and VSS. The comparator has no hysteresis in its input threshold.

Level Shifters

The internal input level-shifter transfers the PWM signal down to the low-side gate driver section. The gate driver section has another level-shifter that level shifts up the high-side gate signal to the high-side gate driver section.

Gate Drivers and DirectFETs

The received PWM signal is sent to the dead-time generation block where a programmable amount of dead time is added into the PWM signal between the two gate output signals of LO and HO to prevent potential cross conduction across the output power DirectFETs. The high-side level-shifter shifts up the high-side gate drive signal out of the dead-time block.

Each channel of the IRS2093's drives two DirectFETs, high- and low-sides, in the power stage providing the amplified PWM waveform.

Output LPF

The amplified PWM output is reconstructed back to an analog signal by the output LC LPF. Demodulation LC low-pass filter (LPF) formed by L1 and C13, filters out the Class D switching carrier signal leaving the audio output at the speaker load. A single stage output filter can be used with switching frequencies of 400 kHz and greater; a design with a lower switching frequency may require an additional stage of LPF.

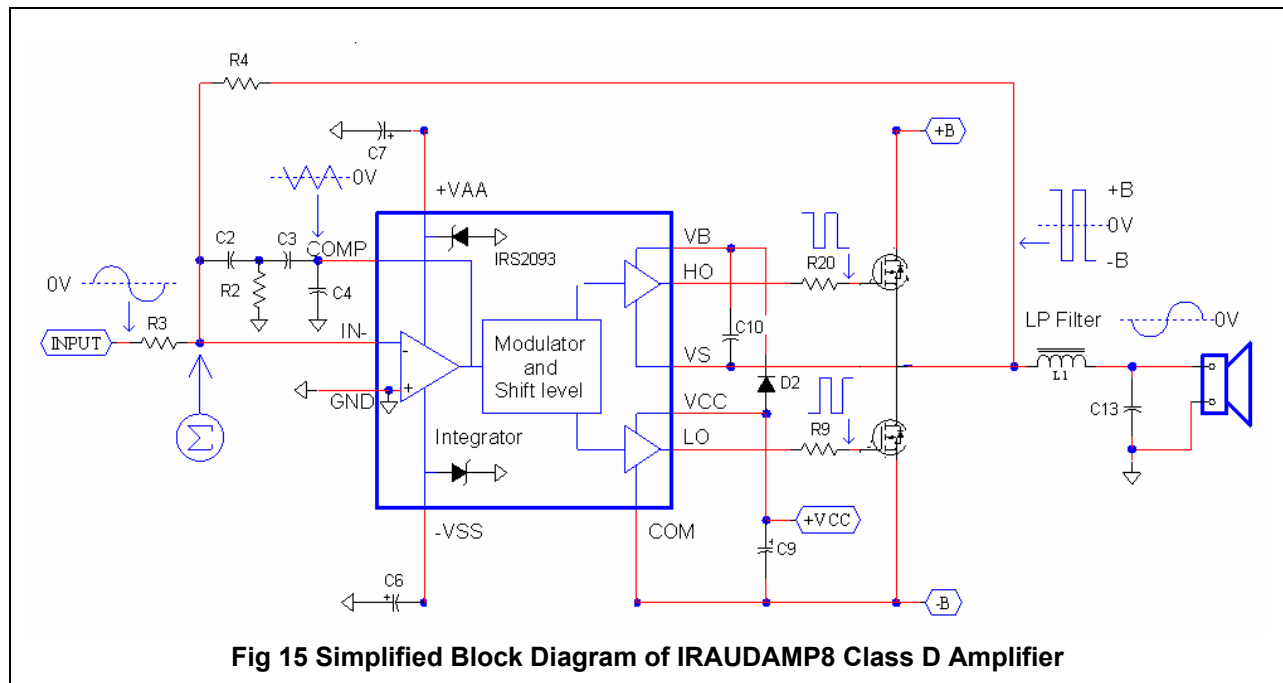

Functional Descriptions

IRS2093 Gate Driver IC

The IRAUDAMP8 uses the IRS2093, a 4 Channel high-voltage (up to 200 V), high-speed power MOSFET driver with internal dead-time and protection functions specifically designed for Class D audio amplifier applications. These functions include OCP and UVP. The IRS2093 integrates bi-directional over current protection for both high-side and low-side MOSFETs. The dead-time can be selected for optimized performance according to the size of the MOSFET, minimizing dead-time while preventing shoot-through. As a result, there is no gate-timing adjustment required externally. Selectable dead-time through the DT pin voltage is an easy and reliable function which requires only two external resistors, R12 and R13 as shown on Fig 16 or Fig 22 below.

The IRS2093 offers the following functions.

- PWM modulator
- Dead-time insertion
- Over current protection
- Under voltage protection
- Level shifters

Refer to IRS2093 datasheet and AN-1146 for more details.

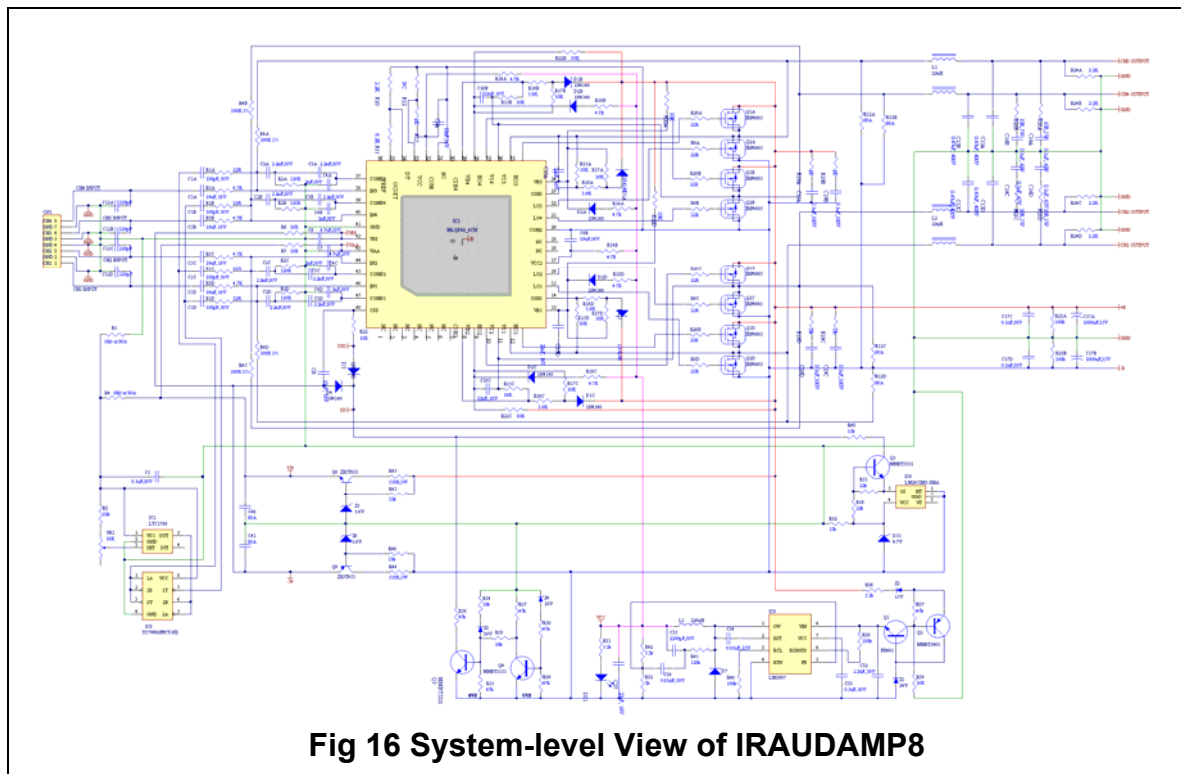

Fig 16 System-level View of IRAUDAMP8

Self-Oscillating Frequency

Self-oscillating frequency is determined by the total delay time along the control loop of the system; the propagation delay of the IRS2093, the DirectFETs switching speed, the time-constant of front-end integrator (R2, R3, R4, C2, C3). Variations in +B and –B supply voltages also affect the self-oscillating frequency.

The self-oscillating frequency changes with the duty ratio. The frequency is highest at idling. It drops as duty cycle varies away from 50%.

Adjustments of Self-Oscillating Frequency

Use R2 to set different self-oscillating frequencies. The PWM switching frequency in this type of self-oscillating switching scheme greatly impacts the audio performance, both in absolute frequency and frequency relative to the other channels. In absolute terms, at higher frequencies, distortion due to switching-time becomes significant, while at lower frequencies, the bandwidth of the amplifier suffers. In relative terms, interference between channels is most significant if the relative frequency difference is within the audible range.

Normally, when adjusting the self-oscillating frequency of the different channels, it is suggested to either match the frequencies accurately, or have them separated by at least 25kHz. Under the normal operating condition with no audio input signal, the switching-frequency is set around 400kHz in the IRAUDAMP8.

Selectable Dead-time

The dead-time of the IRS2093 is set based on the voltage applied to the DT pin. Fig 17 lists the suggested component value for each programmable dead-time between 45 and 105 ns. All the IRAUDAMP8 models use DT1 (45ns) dead-time.

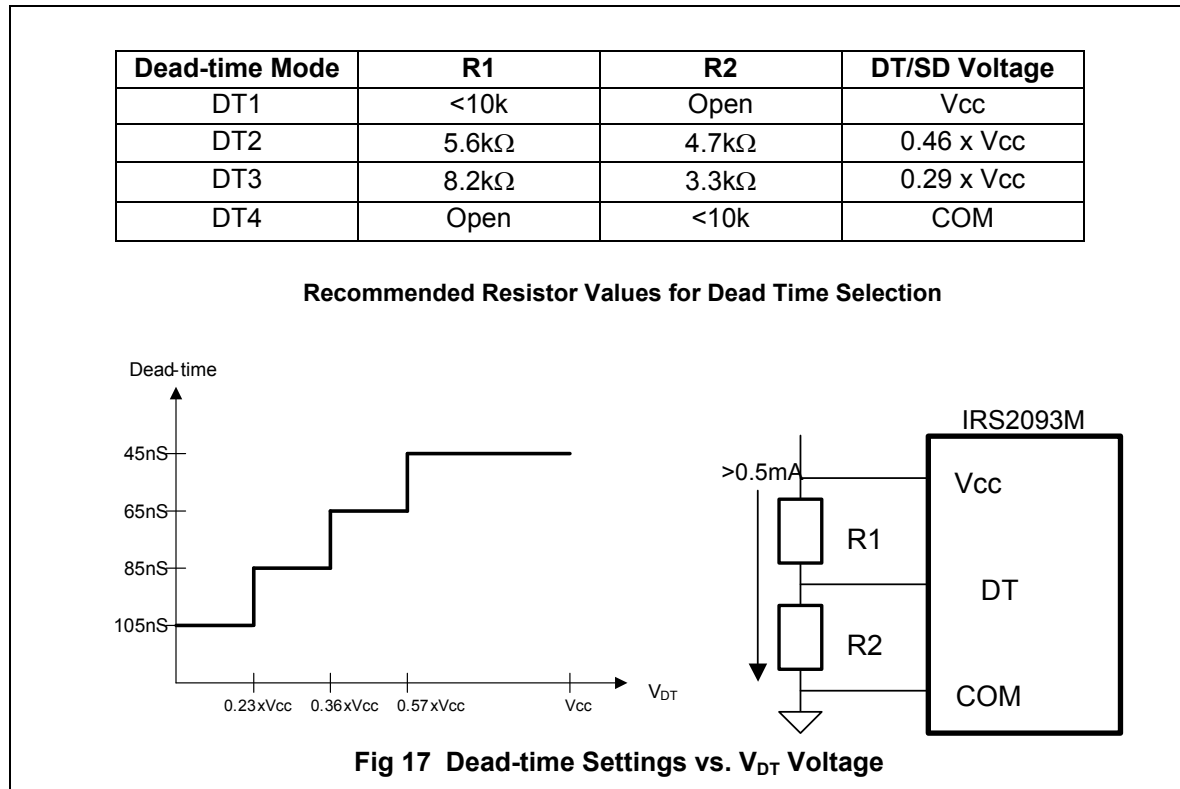

Protection System Overview

The IRS2093 integrates over current protection (OCP) inside the IC. The rest of the protections, such as over-voltage protection (OVP), under-voltage protection (UVP), and over temperature protection (OTP), are detected externally to the IRS2093 (Fig 18).

The external shutdown circuit will disable the output by pulling down CSD pins, (Fig 19). If the fault condition persists, the protection circuit stays in shutdown until the fault is removed.

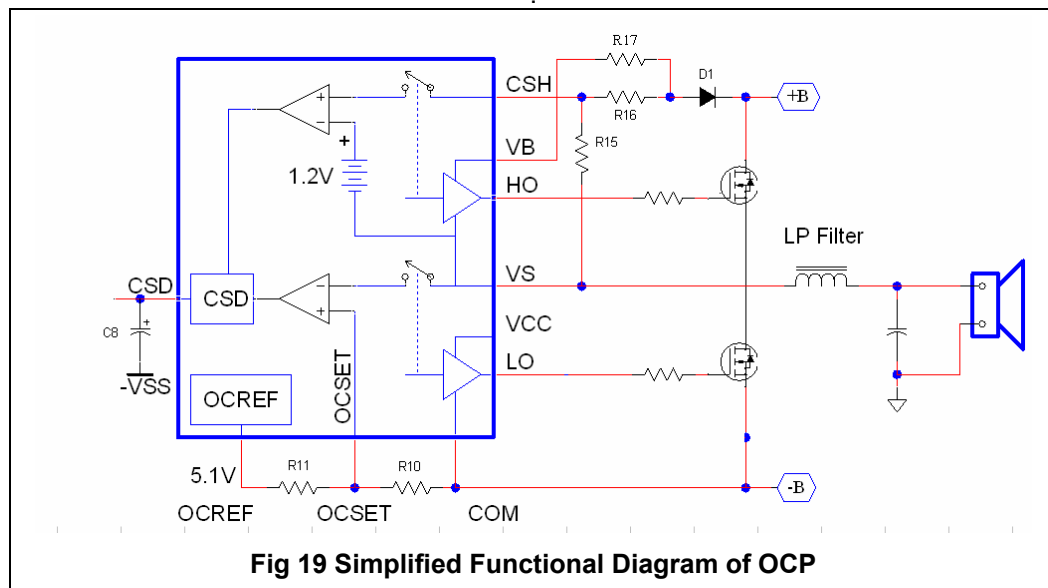
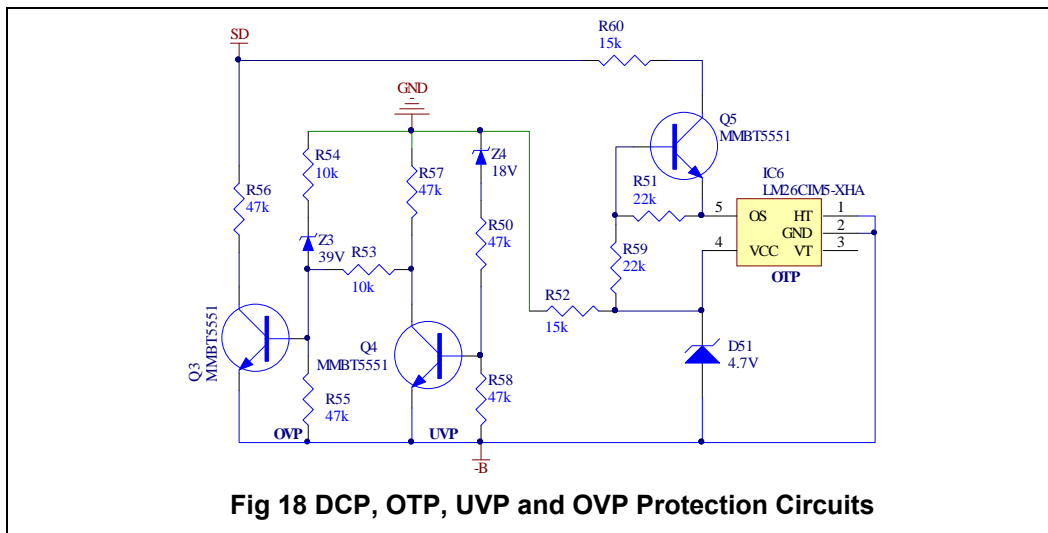

Over-Current Protection (OCP)

Low-Side Current Sensing

The low-side current sensing feature protects the low side DirectFET from an overload condition from negative load current by measuring drain-to-source voltage across $R_{DS(ON)}$ during its on state. OCP shuts down the switching operation if the drain-to-source voltage exceeds a preset trip level.

The voltage setting on the OCSET pin programs the threshold for low-side over-current sensing. When the VS voltage becomes higher than the OCSET voltage during low-side conduction, the IRS2093 turns the outputs off and pulls CSD down to -VSS.

High-Side Current Sensing

The high-side current sensing protects the high side DirectFET from an overload condition from positive load current by measuring drain-to-source voltage across $R_{DS(ON)}$ during its on state. OCP shuts down the switching operation if the drain-to-source voltage exceeds a preset trip level.

High-side over-current sensing monitors drain-to-source voltage of the high-side DirectFET during the on state through the CSH and VS pins. The CSH pin detects the drain voltage with reference to the VS pin, which is the source of the high-side DirectFET. In contrast to the low-side current sensing, the threshold of the CSH pin to trigger OC protection is internally fixed at 1.2V. An external resistive divider R15, R16 and R17 are used to program a threshold as shown in Fig 18. An external reverse blocking diode D1 is required to block high voltage feeding into the CSH pin during low-side conduction. By subtracting a forward voltage drop of 0.6V at D1, the minimum threshold which can be set for the high-side is 0.6V across the drain-to-source.

Over-Voltage Protection (OVP)

OVP is provided externally to the IRS2093. OVP shuts down the amplifier if the bus voltage between GND and -B exceeds 39V. The threshold is determined by a Zener diode Z3. OVP protects the board from harmful excessive supply voltages, such as due to bus pumping at very low frequency-continuous output in stereo mode.

Under-Voltage Protection (UVP)

UVP is provided externally to the IRS2093. UVP prevents unwanted audible noise output from unstable PWM operation during power up and down. UVP shuts down the amplifier if the bus voltage between GND and -B falls below a voltage set by Zener diode Z4.

Offset Null (DC Offset) Adjustment

The IRAUDAMP8 requires no output-offset adjustment. DC offsets are tested to be less than ± 20 mV.

Over-Temperature Protection (OTP)

A Preset Thermostat IC, IC6 in Fig 17, is placed in close proximity to the heatsink which has 8 DirectFETs under it; and monitors heatsink temperature. If the heatsink temperature rises above 100 °C, the OTP shuts down all 4 channels by pulling down the CSD pins of the IRS2093. OTP recovers once the temperature has cooled down.

Click and POP Noise Reduction

Thanks to the click and pop elimination function built into the IRS2093, the IRAUDAMP8 does not require any additional components for this function.

Power Supply Requirements

For convenience, the IRAUDAMP8 has all the necessary housekeeping power supplies onboard and only requires a pair of symmetric power supplies. Or you can use it with the IRAUDPS1 reference design which is a 12 volt systems Audio Power Supply for automotive applications designed to provide voltage rails (+B and -B) for Class D audio power amplifiers .

House Keeping Power Supply

The internally-generated housekeeping power supplies include ± 5 V for analog signal processing, and +12V supply (V_{CC}) referred to the negative supply rail -B for DirectFET gate drive. The gate driver section of the IRS2093 uses V_{CC} to drive gates of the DirectFETs. V_{CC} is referenced to -B (negative power supply). D2, R18 and C10 form a bootstrap floating supply for the HO gate driver.

Bus Pumping

When the IRAUDAMP8 is running in stereo mode, the bus pumping effect takes place with low frequency, high output. Since the energy flowing in the Class D switching stage is bi-directional, there is a period where the Class D amplifier feeds energy back to the power supply. The majority of the energy flowing back to the supply is from the energy stored in the inductor in the output LPF.

Usually, the power supply has no way to absorb the energy coming back from the load. Consequently the bus voltage is pumped up, creating bus voltage fluctuations.

Following conditions make bus pumping worse:

1. Lower output frequencies (bus-pumping duration is longer per half cycle)
2. Higher power output voltage and/or lower load impedance (more energy transfers between supplies)
3. Smaller bus capacitance (the same energy will cause a larger voltage increase)

The OVP protects IRAUDAMP8 from failure in case of excessive bus pumping. One of the easiest counter measures of bus pumping is to drive both of the channels in a stereo configuration out-of-phase so that one channel consumes the energy flow from the other and does not return it to the power supply. Bus voltage detection monitors only +B supply, assuming the bus pumping on the supplies is symmetric in +B and -B supplies.

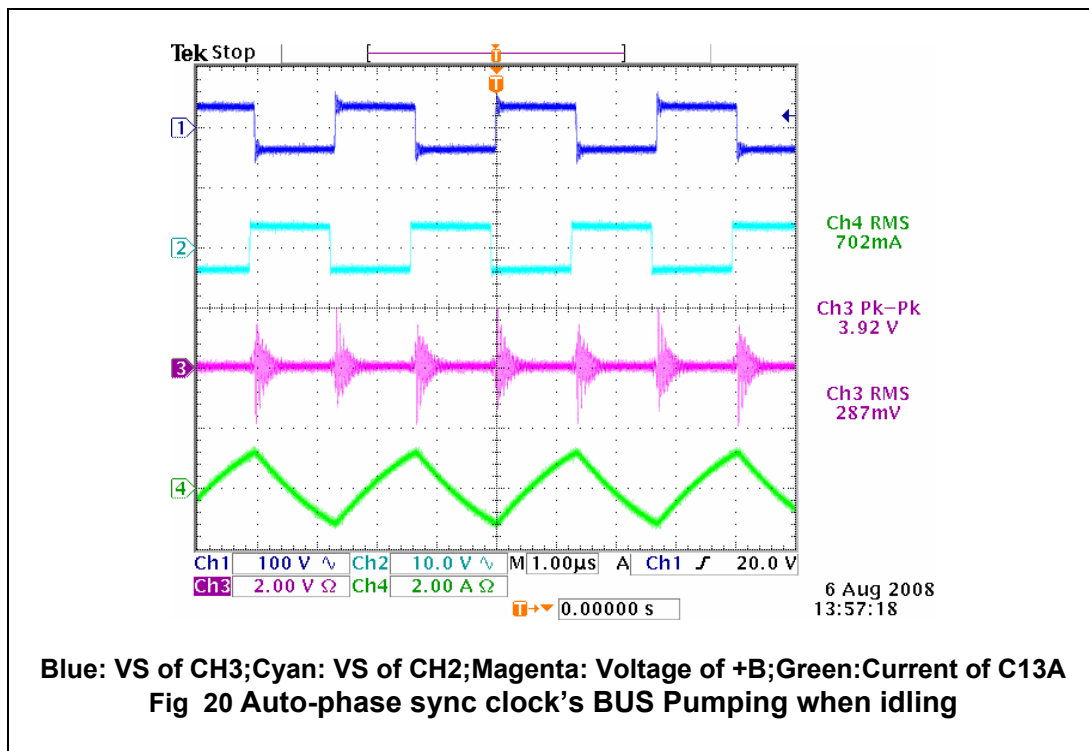

Load Impedance

Each channel is optimized for a 4 Ω speaker load in half bridge.

Input Signal and Gain Setting

A proper input signal is an analog signal ranging from 20Hz to 20kHz with up to 3 V_{RMS} amplitude with a source impedance of no more than 600 Ω . Input signal with frequencies from 30kHz to 60kHz may cause LC resonance in the output LPF, causing a large reactive current flowing through the switching stage, especially with greater than 8 Ω load impedances, and the LC resonance can activate OCP.

The IRAUDAMP8 has an RC network called a Zobel network (R21 and C14) to damp the resonance and prevent peaking frequency response with light loading impedance. (Fig 21)

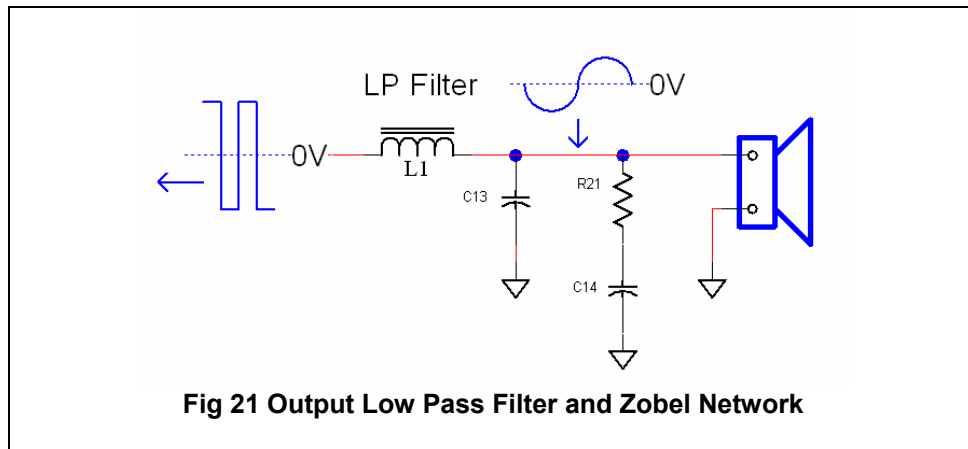

Gain Setting

The ratio of resistors R4A~D/R1A~D in Fig 22 sets voltage gain. The IRAUDAMP8 has no on board volume control. To change the voltage gain, change the input resistor term R1A~D. Changing R4A~D affects PWM control loop design and may result poor audio performance.

Schematic

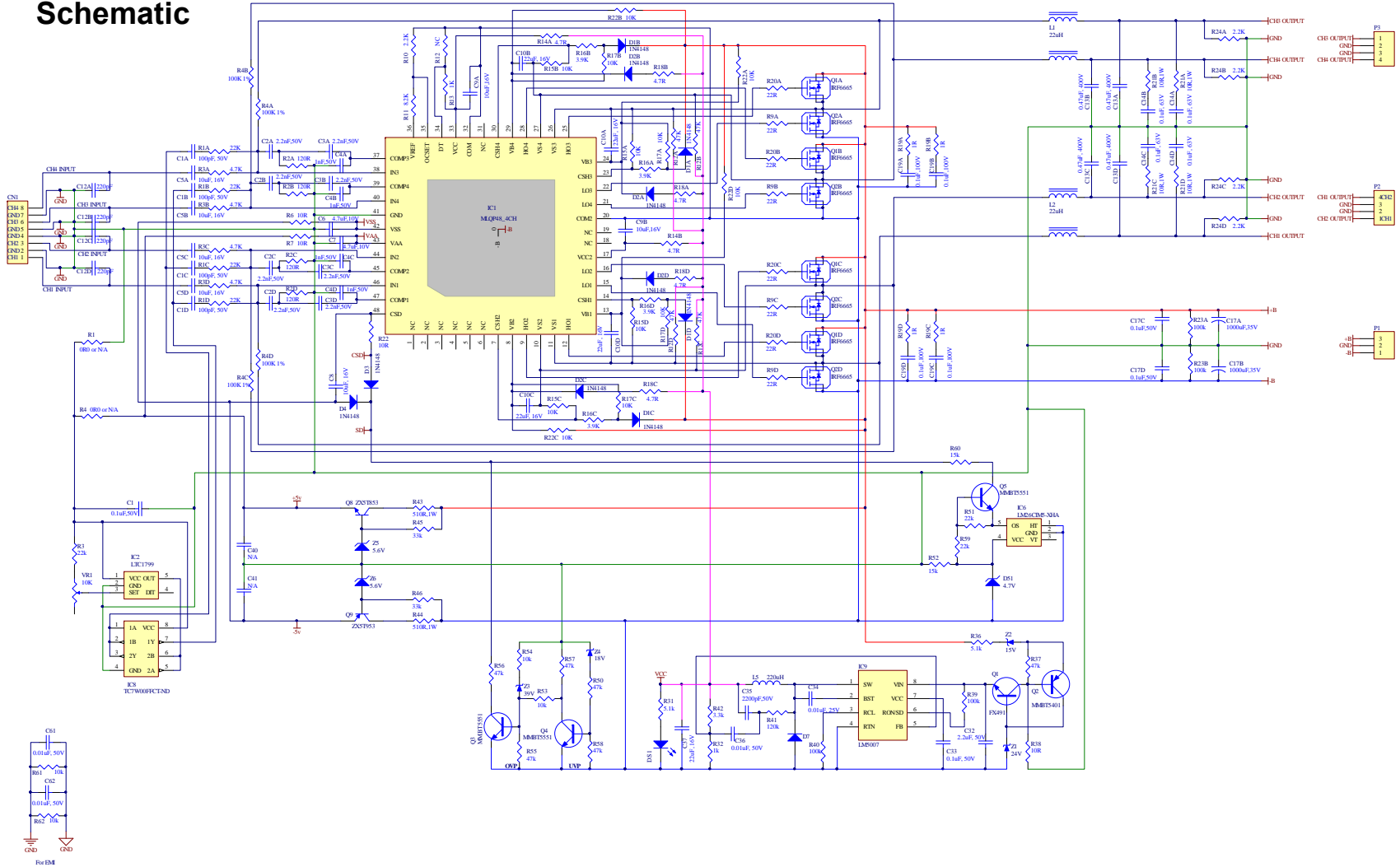

Fig 22 IRAUDAMP8 Schematic

IRAUDAMP8 Fabrication Materials

Table 1 IRAUDAMP8 Electrical Bill of Materials

Quantity	Value	Description	Designator	Part Number	Vender
1	0.1uF,50V	CAP CER .1UF 50V 10% X7R 0603	C1	490-1519-1-ND	Murata Electronics North America
4	100pF, 50V	CAP CERAMIC 100PF 50V NPO 0603	C1A, C1B, C1C, C1D	399-1061-1-ND	Kemet
9	2.2nF,50V	CAP CER 2200PF 50V 10% X7R 0603	C2A, C2B, C2C, C2D, C3A, C3B, C3C, C3D, C35	490-1500-1-ND	Murata Electronics North America
4	1nF,50V	CAP 1000PF 50V CERAMICX7R 0603	C4A, C4B, C4C, C4D	399-1082-1-ND	Kemet
4	10uF, 16V	CAP 10UF 16V HA ELECT SMD	C5A, C5B, C5C, C5D	PCE4179CT-ND	Panasonic - ECG
2	4.7uF,10V	CAP CERM 4.7UF 10V Y5V 0805	C6, C7	478-1429-1-ND	AVX Corporation
1	10uF, 16V	CAP CER 10UF 16V Y5V 1206	C8	490-3383-1-ND	Murata Electronics North America
2	10uF,16V	CAP CER 10UF 16V Y5V 0805	C9A, C9B	490-3347-1-ND	Murata Electronics North America
5	22uF, 16V	CAP CER 22UF 16V X7R 1210	C10A, C10B, C10C, C10D, C37	445-3945-1-ND	TDK Corporation
4	220pF	CAP CER 220PF 50V 10% X7R 0603	C12A, C12B, C12C, C12D	490-1483-1-ND	Murata Electronics North America
4	0.47uF, 400V	CAP .47UF 400V METAL POLYPRO	C13A, C13B, C13C, C13D	495-1315-ND	EPCOS Inc
4	0.1uF, 63V	CAP FILM MKP .1UF 63VDC 2%	C14A, C14B, C14C, C14D	BC2054-ND	Vishay/BC Components
2	1000uF,35V	CAP 1000UF 35V ELECT SMG RAD	C17A, C17B	565-1086-ND	United Chemi-Con
2	0.1uF,50V	CAP .10UF 50V CERAMIC X7R 1206	C17C, C17D	399-1249-1-ND	Kemet
4	0.1uF,100V	CAP CER .10UF 100V X7R 10% 0805	C19A, C19B, C19C, C19D	445-1418-1-ND	TDK Corporation
1	2.2uF, 50V	CAP CER 2.2UF 50V X7R 1206	C32	490-3367-1-ND	Murata Electronics North America
1	0.1uF, 50V	CAP CER .1UF 50V 10% X7R 0805	C33	490-1666-1-ND	Murata Electronics North America
1	0.01uF, 25V	CAP 10000PF 25V CERM X7R 0603	C34	PCC1763CT-ND	Panasonic - ECG
1	0.01uF, 50V	CAP CER 10000PF 50V 20% X7R 0603	C36	490-1511-1-ND	Murata Electronics North America
2	0.01uF, 50V	CAP 10000PF 50V CERAMIC X7R 0603	C61, C62	399-1091-1-ND	Kemet
1	ED1520-ND	TERMINAL BLOCK 3.5MM 8POS PCB	CN1	ED1520-ND	On Shore Technology Inc
10	1N4148	DIODE SWITCH 100V 400MW SOD-123	D1A, D1B, D1C, D1D, D2A, D2B, D2C, D2D, D3, D4	1N4148W-FDICT-ND	Diodes Inc
1	DIODE1	DIODE SCHOTTKY 100V 1.5A SMA	D7	10MQ100NPBFCT-ND	Vishay/Semiconductors
1	4.7V	DIODE ZENER 500MW 4.7V SOD123	D51	MMSZ4V7T1GOSCT-ND	ON Semiconductor
1	Blue LED	LED BLUE CLEAR THIN 0805 SMD	DS1	160-1645-1-ND	Lite-On Inc
1	MLQP48_4CH	4ch Audio Class D Controller	IC1	IR2093MPBF	International Rectifier
1	LTC1799	IC OSCILLATOR RES SET TSOT23-5	IC2	LTC1799CS5#TRMPBFCT-ND	Linear Technology
1	LM26CIM5-XHA	IC THERMOSTAT PRESET SOT23-5	IC6	LM26CIM5-XHACT-ND	National Semiconductor
1	TC7W00FFCT-ND	IC GATE NAND DUAL 2INPUT 8-SOP	IC8	TC7W00FFCT-ND	Toshiba
1	LM5007	IC REG SW STEP-DOWN 80V 8-LLP	IC9	LM5007SDCT-ND	National Semiconductor

2	22uH	Fixed inductors for Digital Audio Amplifier	L1, L2	DAEPW-M185X	TOKO
1	220uH	POWER INDUCTOR 220UH 0.49A SMD	L5	308-1538-1-ND	Sumida Corporation
1	Header 3	CONN TERM BLOCK PCB 5.0MM 3POS	P1	281-1415-ND	Weidmuller
2	SP OUT	TERMINAL BLOCK 3.5MM 4POS PCB	P2, P3	ED1516-ND	On Shore Technology Inc
1	FX491	TRANS HP NPN 60V 1000MA SOT-23	Q1	FMMT491CT-ND	Zetex Inc
8	IRF6665	MOSFET N-CH 100V 4.2A DIRECTFET	Q1A, Q1B, Q1C, Q1D, Q2A, Q2B, Q2C, Q2D	IRF6665TRPBFCT-ND	International Rectifier
1	MMBT5401	TRANS 150V 350MW PNP SMD SOT-23	Q2	MMBT5401-FDICT-ND	Diodes Inc
3	MMBT5551	TRANS NPN 160V 350MW SMD SOT-23	Q3, Q4, Q5	MMBT5551-FDICT-ND	Diodes Inc
1	ZX5T853	TRANSISTOR 4.5A 100V SOT-89	Q8	ZX5T853ZCT-ND	Zetex Inc
1	ZX5T953	TRANSISTOR PNP 3.5A 100V SOT-89	Q9	ZX5T953ZCT-ND	Zetex Inc
1	0R0	RES ZERO OHM 1/10W 5% 0603 SMD	R1	P0.0GCT-ND	Panasonic - ECG
7	22K	RES 22K OHM 1/10W 5% 0603 SMD	R1A, R1B, R1C, R1D, R3, R51, R59	RHM22KGCT-ND	Rohm
4	120R	RES 120 OHM 1/10W 5% 0603 SMD	R2A, R2B, R2C, R2D	RHM120GCT-ND	Rohm
4	4.7K	RES 4.7K OHM 1/10W 5% 0603 SMD	R3A, R3B, R3C, R3D	RHM4.7KGCT-ND	Rohm
4	100K 1%	RES 100K OHM 1/8W 1% 0805 SMD	R4A, R4B, R4C, R4D	RHM100KCRCT-ND	Rohm
4	10R	RES 10 OHM 1/10W 5% 0603 SMD	R6, R7, R22, R38	RHM10GCT-ND	Rohm
8	22R	RES 22 OHM 1/10W 5% 0603 SMD	R9A, R9B, R9C, R9D, R20A, R20B, R20C, R20D	RHM22GCT-ND	Rohm
1	2.2K	RES 2.2K OHM 1/10W 5% 0603 SMD	R10	RHM2.2KGCT-ND	Rohm
1	8.2K	RES 8.2K OHM 1/10W 5% 0603 SMD	R11	RHM8.2KGCT-ND	Rohm
2	1K	RES 1.0K OHM 1/10W 5% 0603 SMD	R13, R32	RHM1.0KGCT-ND	Rohm
6	4.7R	RES 4.7 OHM 1/10W 5% 0603 SMD	R14A, R14B, R18A, R18B, R18C, R18D	RHM4.7GCT-ND	Rohm
16	10K	RES 10K OHM 1/10W 5% 0603 SMD'	R15A, R15B, R15C, R15D, R17A, R17B, R17C, R17D, R22A, R22B, R22C, R22D, R53, R54, R61, R62	RHM10KGCT-ND	Rohm
4	3.9K	RES 3.9K OHM 1/10W 5% 0603 SMD	R16A, R16B, R16C, R16D	RHM3.9KGCT-ND	Rohm
4	1R	RES 1.0 OHM 1/8W 5% 0805 SMD	R19A, R19B, R19C, R19D	RHM1.0ARCT-ND	Rohm
4	10R,1W	RES 10 OHM 1W 1% 2512 SMD	R21A, R21B, R21C, R21D	PT10AECT-ND	Panasonic - ECG
4	100k	RES 100K OHM 1/10W 5% 0603 SMD	R23A, R23B, R39, R40	RHM100KGCT-ND	Rohm
4	2.2K	RES 2.2K OHM 1/8W 5% 0805 SMD	R24A, R24B, R24C, R24D	RHM2.2KARCT-ND	Rohm
1	5.1k	RES 5.1K OHM 1/8W 5% 0805 SMD	R31	RHM5.1KARCT-ND	Rohm
1	5.1k	RES 5.1K OHM 1/10W 5% 0603 SMD	R36	RHM5.1KGCT-ND	Rohm
6	47k	RES 47K OHM 1/10W 5% 0603 SMD	R37, R50, R55, R56, R57, R58	RHM47KGCT-ND	Rohm
1	120k	RES 120K OHM 1/10W 5% 0603 SMD	R41	RHM120KGCT-ND	Rohm
1	3.3k	RES 3.3K OHM 1/10W 5% 0603 SMD	R42	RHM3.3KGCT-ND	Rohm

2	510R,1W	RES 510 OHM 1W 5% 2512 SMD	R43, R44	PT510XCT-ND	Panasonic - ECG
2	33k	RES 33K OHM 1/10W 5% 0603 SMD	R45, R46	RHM33KGCT-ND	Rohm
2	15k	RES 15K OHM 1/10W 5% 0603 SMD	R52, R60	RHM15KGCT-ND	Rohm
1	10K	POT 10K OHM 3MM CERM SQ TOP SMD	VR1	ST32ETB103CT-ND	Copal Electronics Inc
1	24V	DIODE ZENER 500MW 24V SOD123	Z1	BZT52C24-FDICT-ND	Diodes Inc
1	15V	DIODE ZENER 500MW 15V SOD123	Z2	BZT52C15-FDICT-ND	Diodes Inc
1	39V	DIODE ZENER 39V 500MW SOD-123	Z3	BZT52C39-FDICT-ND	Diodes Inc
1	18V	DIODE ZENER 500MW 18V SOD123	Z4	BZT52C18-FDICT-ND	Diodes Inc
2	5.6V	DIODE ZENER 500MW 5.6V SOD123	Z5, Z6	MMSZ5V6T1GOSCT-ND	ON Semiconductor

Table 2 IRAUDAMP8 Mechanical Bill of Materials

Quantity	Value	Description	Designator	Digikey P/N	Vendor
7	Washer #4 SS	WASHER LOCK INTERNAL #4 SS	Lock washer 1, Lock washer 2, Lock washer 3, Lock washer 4, Lock washer 5, Lock washer 6 Lock washer 7	H729-ND	Building Fasteners
1	PCB	Print Circuit Board IRAUDAM8M_Rev 3.0 .PCB	PCB 1		Custom
7	Screw 4-40X5/16	SCREW MACHINE PHILLIPS 4-40X5/16	Screw 1, Screw 2, Screw 3, Screw 4, Screw 5, Screw 6, Screw 7,	H343-ND	Building Fasteners
4	Stand off 0.5"	STANDOFF HEX 4-40THR .500"L ALUM	Stand Off 1, Stand Off 2, Stand Off 3, Stand Off 4	1893K-ND	Keystone Electronics
1/16	AAVID 4880G	THERMAL PAD .080" 4X4" GAPPAD	thermal pad under heatsink	BER164-ND	Thermal alloy

IRAUDAMP8 Hardware

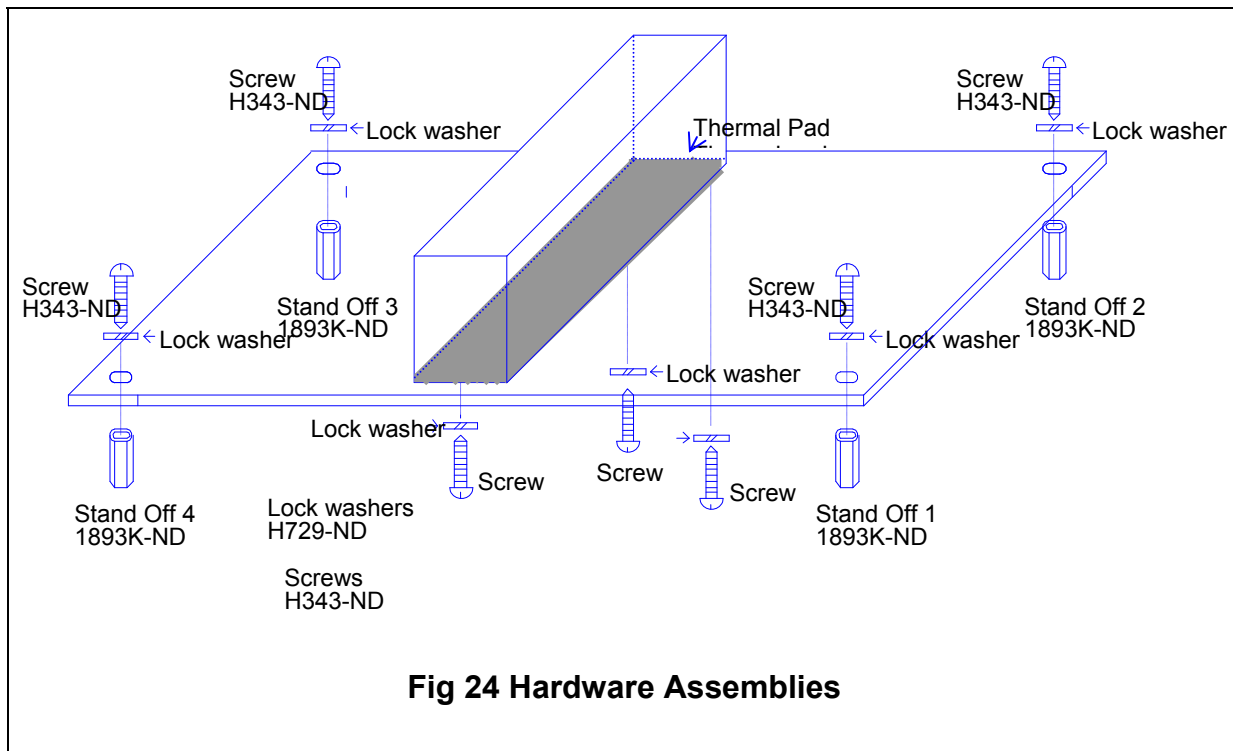
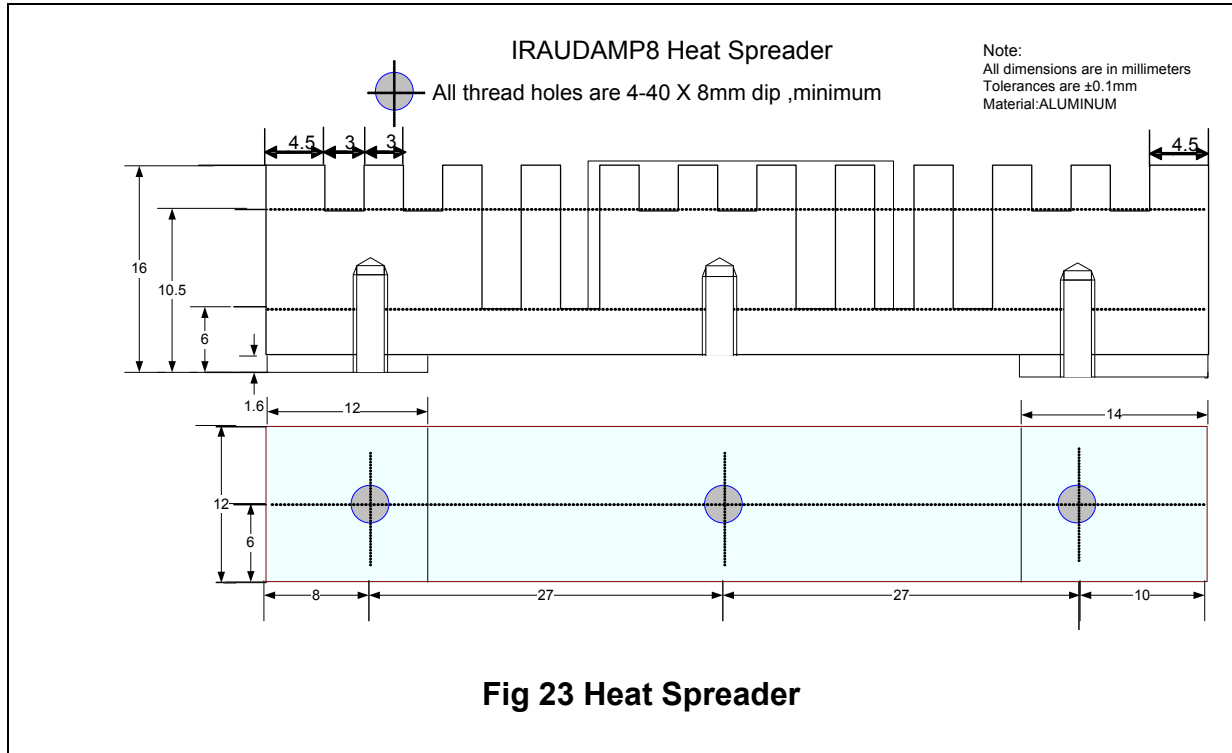

IRAUDAMP8 PCB Specifications

PCB:

1. Two Layers SMT PCB with through holes
2. 1/16 thickness
3. 2/0 OZ Cu
4. FR4 material
5. 10 mil lines and spaces
6. Solder Mask to be Green enamel EMP110 DBG (CARAPACE) or Enthone Endplate DSR-3241 or equivalent.
7. Silk Screen to be white epoxy non conductive per IPC-RB 276 Standard.
8. All exposed copper must finished with TIN-LEAD Sn 60 or 63 for 100u inches thick.
9. Tolerance of PCB size shall be 0.010 -0.000 inches
10. Tolerance of all Holes is -.000 + 0.003"
11. PCB acceptance criteria as defined for class II PCB'S standards.

Gerber Files Apertures Description:

All Gerber files stored in the attached CD-ROM were generated from Protel Altium Designer Altium Designer 6. Each file name extension means the following:

1. .gtl Top copper, top side
2. .gbl Bottom copper, bottom side
3. .gto Top silk screen
4. .gbo Bottom silk screen
5. .gts Top Solder Mask
6. .gbs Bottom Solder Mask
7. .gko Keep Out,
8. .gm1 Mechanical1
9. .gd1 Drill Drawing
10. .gg1 Drill locations
11. .txt CNC data
12. .apr Apertures data

Additional files for assembly that may not be related with Gerber files:

13. .pcb PCB file
14. .bom Bill of materials
15. .cpl Components locations
16. .sch Schematic
17. .csv Pick and Place Components
18. .net Net List
19. .bak Back up files
20. .lib PCB libraries

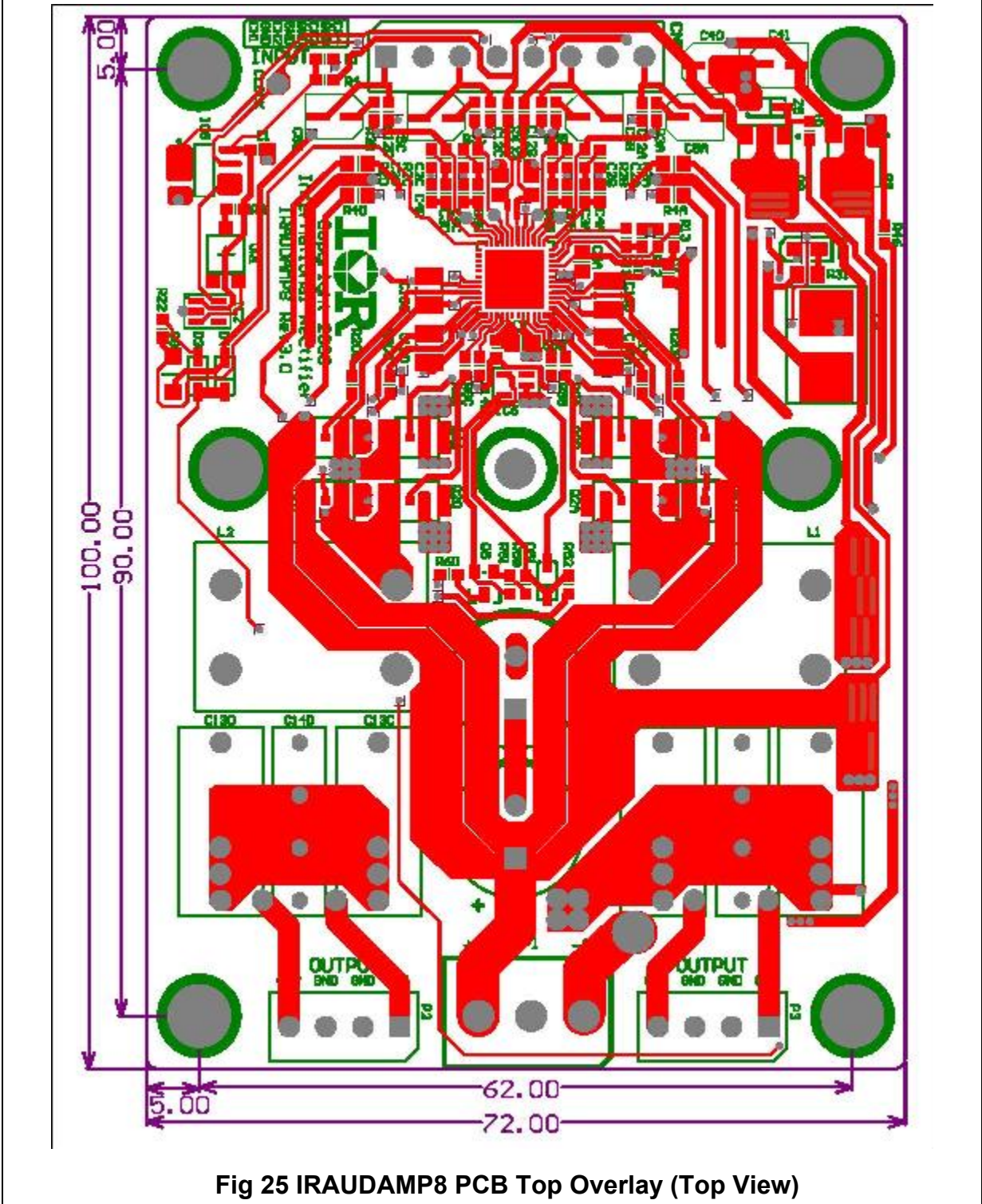

Fig 25 IRAUDAMP8 PCB Top Overlay (Top View)

Revision changes descriptions

Revision	Changes description	Date
Rev 1.0	Released	Jan, 08 th 2009
Rev 1.1	ROHS Compliant (BOM Updated)	May, 29 th 2009

Компания «Океан Электроники» предлагает заключение долгосрочных отношений при поставках импортных электронных компонентов на взаимовыгодных условиях!

Наши преимущества:

- Поставка оригинальных импортных электронных компонентов напрямую с производств Америки, Европы и Азии, а так же с крупнейших складов мира;
- Широкая линейка поставок активных и пассивных импортных электронных компонентов (более 30 млн. наименований);
- Поставка сложных, дефицитных, либо снятых с производства позиций;
- Оперативные сроки поставки под заказ (от 5 рабочих дней);
- Экспресс доставка в любую точку России;
- Помощь Конструкторского Отдела и консультации квалифицированных инженеров;
- Техническая поддержка проекта, помощь в подборе аналогов, поставка прототипов;
- Поставка электронных компонентов под контролем ВП;
- Система менеджмента качества сертифицирована по Международному стандарту ISO 9001;
- При необходимости вся продукция военного и аэрокосмического назначения проходит испытания и сертификацию в лаборатории (по согласованию с заказчиком);
- Поставка специализированных компонентов военного и аэрокосмического уровня качества (Xilinx, Altera, Analog Devices, Intersil, Interpoint, Microsemi, Actel, Aeroflex, Peregrine, VPT, Syfer, Eurofarad, Texas Instruments, MS Kennedy, Miteq, Cobham, E2V, MA-COM, Hittite, Mini-Circuits, General Dynamics и др.);

Компания «Океан Электроники» является официальным дистрибьютором и эксклюзивным представителем в России одного из крупнейших производителей разъемов военного и аэрокосмического назначения «JONHON», а так же официальным дистрибьютором и эксклюзивным представителем в России производителя высокотехнологичных и надежных решений для передачи СВЧ сигналов «FORSTAR».



JONHON

«JONHON» (основан в 1970 г.)

Разъемы специального, военного и аэрокосмического назначения:

(Применяются в военной, авиационной, аэрокосмической, морской, железнодорожной, горно- и нефтедобывающей отраслях промышленности)

«FORSTAR» (основан в 1998 г.)

ВЧ соединители, коаксиальные кабели, кабельные сборки и микроволновые компоненты:

(Применяются в телекоммуникациях гражданского и специального назначения, в средствах связи, РЛС, а так же военной, авиационной и аэрокосмической отраслях промышленности).



Телефон: 8 (812) 309-75-97 (многоканальный)

Факс: 8 (812) 320-03-32

Электронная почта: ocean@oceanchips.ru

Web: <http://oceanchips.ru/>

Адрес: 198099, г. Санкт-Петербург, ул. Калинина, д. 2, корп. 4, лит. А