

General Description

The MAX696/MAX697 supervisory circuits reduce the complexity and number of components required for power-supply monitoring and battery-control functions in microprocessor (μ P) systems. These include μ P reset and backup-battery switchover, watchdog timer, CMOS RAM write protection, and power-failure warning. The MAX696/MAX697 significantly improve system reliability and accuracy compared to that obtained with separate ICs or discrete components.

The MAX696 and MAX697 are supplied in 16-pin packages and perform six functions:

- 1) A reset output during power-up, power-down, and brownout conditions. The threshold for this "lowline" reset is adjustable by an external voltage divider.
- 2) A reset pulse if the optional watchdog timer has not been toggled within a specified time.
- 3) Individual outputs for low-line and watchdog fault conditions.
- 4) The reset time may be left at its default value of 50ms, or may be varied with an external capacitor or clock pulses.
- 5) A separate 1.3V threshold detector for power-fail warning, low-battery detection, or to monitor a power supply other than V_{CC} .

The MAX696 also has battery-backup switching for CMOS RAM, CMOS microprocessor, or other lowpower logic.

The MAX697 lacks battery-backup switching, but has write-protection pins (\overline{CE} IN and \overline{CE} OUT) for CMOS RAM or EPROM. In addition, it consumes less than 250 microamperes.

Applications

- Computers
- Controllers
- Intelligent Instruments
- Critical μ P Power Monitoring

Typical Operating Circuit appears at end of data sheet.

Pin Configurations continued at end of data sheet.

Features

- Adjustable Low-Line Monitor and Power-Down Reset
- Power-OK/Reset Time Delay
- Watchdog Timer—100ms, 1.6s, or Adjustable
- Minimum Component Count
- 1 μ A Standby Current
- Battery-Backup Power Switching (MAX696)
- On-Board Gating of Chip-Enable Signals (MAX697)
- Separate Monitor for Power-Fail or Low-Battery Warning

Ordering Information

PART	TEMP RANGE	PIN-PACKAGE
MAX696C/D	0°C to +70°C	Dice
MAX696CPE	0°C to +70°C	16 PDIP
MAX696CWE	0°C to +70°C	16 Wide SO
MAX696EPE	-40°C to +85°C	16 PDIP
MAX696EJE	-40°C to +85°C	16 CERDIP
MAX696EWE	-40°C to +85°C	16 Wide SO
MAX696MJE	-55°C to +125°C	16 CERDIP

Ordering Information continued at end of data sheet.

Devices in PDIP and SO packages are available in both leaded and lead(Pb)-free packaging. Specify lead free by adding the + symbol at the end of the part number when ordering. Lead free not available for CERDIP package.

Pin Configurations

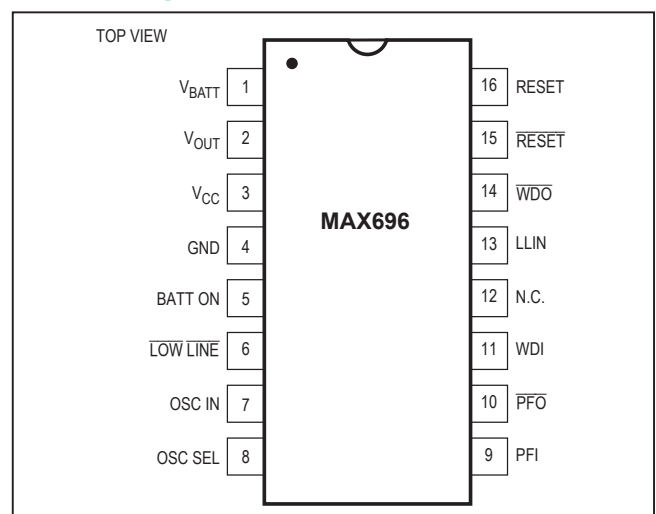

Absolute Maximum Ratings

Terminal Voltage (with respect to GND)		Rate-of-Rise, V_{BATT} , V_{CC}	100V/ μ s
V_{CC}	-0.3V to +6V	Operating Temperature Range	
V_{BATT}	-0.3V to +6V	C Suffix.....	0°C to +70°C
All Other Inputs (Note 1).....	-0.3V to ($V_{OUT} + 0.5V$)	E Suffix.....	-40°C to +85°C
Input Current		M Suffix.....	-55°C to +125°C
V_{CC}	200mA	Power Dissipation ($T_A = +70^\circ C$)	
V_{BATT}	50mA	16-Pin PDIP (derated 7mW/ $^\circ C$ above +70°C).....	600mW
GND.....	20mA	16-Pin SO (derated 7mW/ $^\circ C$ above +70°C).....	600mW
Output Current		16-Pin CERDIP (derated 10mW/ $^\circ C$ above +85°C).....	600mW
V_{OUT}	Short-Circuit Protected	Storage Temperature Range.....	-65°C to +160°C
All Other Outputs.....	20mA	Lead Temperature (soldering, 10s).....	+300°C

Note 1: The input voltage limits on PFI and WDI may be exceeded providing the input current is limited to less than 10mA.

Stresses beyond those listed under "Absolute Maximum Ratings" may cause permanent damage to the device. These are stress ratings only, and functional operation of the device at these or any other conditions beyond those indicated in the operational sections of the specifications is not implied. Exposure to absolute maximum rating conditions for extended periods may affect device reliability.

Electrical Characteristics

(V_{CC} = full operating range, $V_{BATT} = 2.8V$, $T_A = +25^\circ C$, unless otherwise noted.)

PARAMETER	CONDITIONS	MIN	TYP	MAX	UNITS	
Operating Voltage Range	$T_A = \text{full}$	MAX696 V_{CC}	3.0		5.5	V
		MAX696 V_{BATT}	2.0	$V_{CC} - 0.3V$		
		MAX697 V_{CC}	3.0		5.5	
Supply Current (MAX697)	$T_A = \text{full}$		160	300	μA	
BATTERY-BACKUP SWITCHING (MAX696)						
V_{OUT} Output Voltage	$I_{OUT} = 1mA, T_A = \text{full}$	$V_{CC} - 0.3$	$V_{CC} - 0.1$		V	
	$I_{OUT} = 50mA, T_A = \text{full}$	$V_{CC} - 0.5$	$V_{CC} - 0.25$			
V_{OUT} in Battery-Backup Mode	$I_{OUT} = 250\mu A, V_{CC} < (V_{BATT} - 0.2V), T_A = \text{full}$	$V_{BATT} - 0.1$	$V_{BATT} - 0.02$		V	
Supply Current (Excludes I_{OUT})	$I_{OUT} = 1mA$		1.5	4	mA	
	$I_{OUT} = 50mA$		2.5	7		
Supply Current in Battery-Backup Mode	$V_{CC} = 0V, V_{BATT} = 2.8V, T_A = +25^\circ C$		0.6	1	μA	
	$V_{CC} = 0V, V_{BATT} = 2.8V, T_A = \text{full}$			10		
Battery Standby Leakage Current	$5.5V > V_{CC} > (V_{BATT} + 0.3V)$	$T_A = +25^\circ C$	-100	+20	nA	
		$T_A = \text{full}$	-1.00	+0.02	μA	
Battery Switchover Threshold $V_{CC} - V_{BATT}$	Power-up		70		mV	
	Power-down		50			
Battery Switchover Hysteresis			20		mV	
BATT ON Output Voltage	$I_{SINK} - 1.6mA$			0.4	V	
BATT ON Output Short-Circuit Current	BATT ON = $V_{OUT} = 2.4V$ sink current		7		mA	
	BATT ON = $V_{OUT}, V_{CC} = 0V$	0.5	2.5	25.0		μA
RESET AND WATCHDOG TIMER						
Low-Line Voltage Threshold (LL_{IN})	$V_{CC} = +5V, +3V; T_A = \text{full}$	1.25	1.30	1.35	V	
Reset Timeout Delay	Figure 6, OSC SEL HIGH, $V_{CC} = 5V$	35	50	70	ms	
Watchdog Timeout Period, Internal Oscillator	Long period, $V_{CC} = 5V$	1.00	1.6	2.25	s	
	Short period, $V_{CC} = 5V$	70	100	140	ms	

Electrical Characteristics (continued)(V_{CC} = full operating range, V_{BATT} = 2.8V, T_A = +25°C, unless otherwise noted.)

PARAMETER	CONDITIONS	MIN	TYP	MAX	UNITS
Watchdog Timeout Period, External Clock	Long period	4032		4097	Clock cycles
	Short period	960		1025	
Minimum WDI Input Pulse Width	V _{IL} = 0.4V, V _{IH} = 3.5V, V _{CC} = 5V	200			ns
$\overline{\text{RESET}}$ and RESET Output Voltage (Note 2)	I _{SINK} = 400μA, V _{CC} = 2V, V _{BATT} = 0V			0.4	V
	I _{SINK} = 1.6mA, 3V < V _{CC} < 5.5V			0.4	
	I _{SOURCE} = 1μA, V _{CC} = 5V	3.5			
LOW LINE and $\overline{\text{WDO}}$ Output Voltage	I _{SINK} = 800μA, T _A = full			0.4	V
	I _{SOURCE} = 1μA, V _{CC} = 5V, T _A = full	3.5			
Output Short-Circuit Current	$\overline{\text{RESET}}$, RESET, $\overline{\text{WDO}}$, LOW LINE	1	3	25	μA
WDI Input Threshold	V _{CC} = 5V (Note 3)	Logic-low		0.8	V
		Logic-high (MAX696)	3.5		
		Logic-high (MAX697)	3.8		
WDI Input Current	V _{WDI} = V _{OUT}		20	50	μA
	V _{WDI} = 0V	-50	-15		
POWER-FAIL DETECTOR					
PFI Input Threshold	V _{CC} = 3V, 5V	1.2	1.3	1.4	V
PFI - LL _{IN} Threshold Difference	V _{CC} = 3V, 5V		±15	±50	mV
PFI Input Current			±0.01	±25	nA
LL _{IN} Input Current	MAX697	-25	±0.01	+25	nA
	MAX696	-500	±0.01	+25	
$\overline{\text{PFO}}$ Output Voltage	I _{SINK} = 1.6mA			0.4	V
	I _{SOURCE} = 1μA, V _{CC} = 5V	3.5			
$\overline{\text{PFO}}$ Short-Circuit Source Current	V _{PFI} = 0V, V _{$\overline{\text{PFO}}$} = 0V	1	3	25	μA
CHIP-ENABLE GATING (MAX697)					
$\overline{\text{CE}}$ IN Thresholds	V _{IL}			0.8	V
	V _{IH} , V _{CC} = 5V	3.0			
$\overline{\text{CE}}$ IN Pullup Current			3		μA
$\overline{\text{CE}}$ OUT Output Voltage	I _{SINK} = 1.6mA			0.4	V
	I _{SOURCE} = 800μA	V _{CC} - 0.5V			
	I _{SOURCE} = 1μA, V _{CC} = 0V	V _{CC} - 0.05V			
$\overline{\text{CE}}$ Propagation Delay	V _{CC} = 5V		80	150	ns
OSCILLATOR					
OSC IN Input Current			±2		μA
OSC SEL Input Pullup Current			5		μA
OSC IN Frequency Range	V _{OSC SEL} = 0V	0		250	kHz
OSC IN Frequency with External Capacitor	V _{OSC SEL} = 0V, C _{OSC} = 47pF		4		kHz

Note 2: T_A = full operating range**Note 3:** WDI is guaranteed to be in the mid-level (inactive) state if WDI is floating and V_{CC} is in the operating voltage range. WDI is internally biased to 38% of V_{CC} with an impedance of approximately 125kΩ.

Typical Operating Characteristics

($T_A = +25^\circ\text{C}$, unless otherwise noted.)

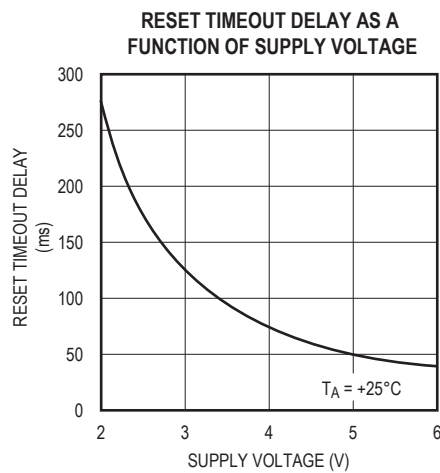
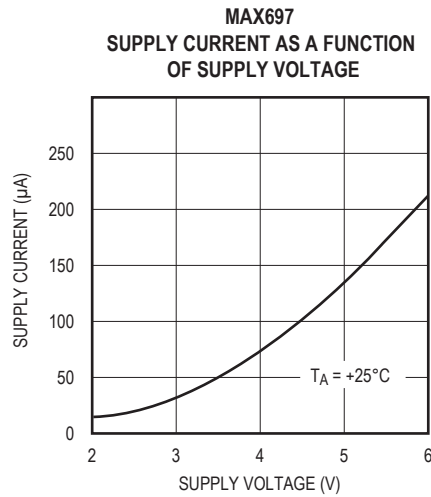
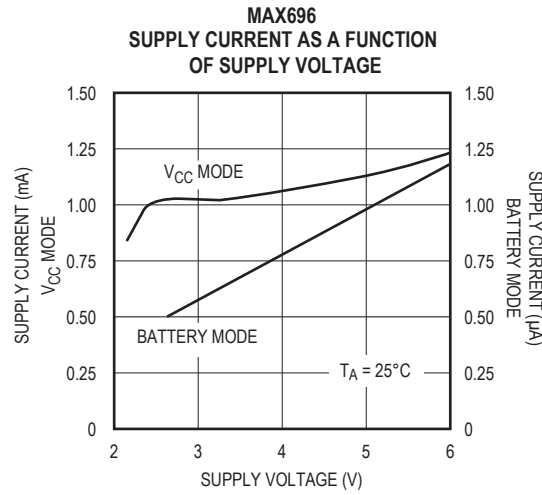

Pin Description

PIN		NAME	FUNCTION
MAX696	MAX697		
1	—	V _{BATT}	Backup-Battery Input. Connect to ground if a backup battery is not used.
2	—	V _{OUT}	The higher of V _{CC} or V _{BATT} is internally switched to V _{OUT} . Connect V _{OUT} to V _{CC} if V _{OUT} and V _{BATT} are not used.
3	3	V _{CC}	+5V Input
4	5	GND	0V Ground Reference for All Signals
5	—	BATT ON	BATT ON goes High when V _{OUT} is Internally Switched to the V _{BATT} Input. It goes low when V _{OUT} is internally switched to V _{CC} . The output typically sinks 7mA and can directly drive the base of an external pnp transistor to increase the output current above the 50mA rating of V _{OUT} .
6	6	$\overline{\text{LOW LINE}}$	$\overline{\text{LOW LINE}}$ goes Low when LL _{IN} Falls Below 1.3V. It returns high as soon as LL _{IN} rises above 1.3V. See Figure 5.
7	7	OSC IN	OSC IN Sets the Reset Delay Timing and Watchdog Timeout Period when OSC SEL Floats or is Driven Low. The timing can also be adjusted by connecting an external capacitor to this pin. See Figure 7. When OSC SEL is high, OSC IN selects between fast and slow watchdog timeout periods
8	8	OSC SEL	When OSC SEL is Unconnected or Driven High, the Internal Oscillator Sets the Reset Time Delay and Watchdog Timeout Period. When OSC SEL is low, the external oscillator input, OSC IN, is enabled. OSC SEL has a 3 μ A internal pullup. See Table 1.
9	9	PFI	PFI is the Noninverting Input to the Power-Fail Comparator. When PFI is less than 1.3V, PFO goes low. Connect PFI to GND or V _{OUT} when not used. See Figure 1.
10	10	$\overline{\text{PFO}}$	$\overline{\text{PFO}}$ is the Output of the Power-Fail Comparator. It goes low when PFI is less than 1.3V. The comparator is turned off and $\overline{\text{PFO}}$ goes low when V _{CC} is below V _{BATT} .
11	11	WDI	The Watchdog Input, WDI, is a Three-Level Input. If WDI remains either high or low for longer than the watchdog timeout period, RESET pulses low and $\overline{\text{WDO}}$ goes low. The watchdog timer is disabled when WDI is left floating or is driven to mid-supply. The timer resets with each transition at the watchdog timer input.
12	2	N.C.	No Connection. Leave this pin open.
13	4	LL _{IN}	Low-Line Input. LL _{IN} is the CMOS input to a comparator whose other input is a precision 1.3V reference. The output is $\overline{\text{LOW LINE}}$ and is also connected to the reset pulse generator. See Figure 2.
14	14	$\overline{\text{WDO}}$	The Watchdog Output, $\overline{\text{WDO}}$, goes Low if WDI Remains either High or Low for Longer than the Watchdog Timeout Period. $\overline{\text{WDO}}$ is set high by the next transition at WDI. If WDI is unconnected or at mid-supply, $\overline{\text{WDO}}$ remains high. $\overline{\text{WDO}}$ also goes high when $\overline{\text{LOW LINE}}$ goes low.
15	15	$\overline{\text{RESET}}$	$\overline{\text{RESET}}$ goes Low whenever LL _{IN} Falls Below 1.3V or V _{CC} Falls Below the V _{BATT} Input Voltage. $\overline{\text{RESET}}$ remains low for 50ms after LL _{IN} goes above 1.3V. $\overline{\text{RESET}}$ also goes low for 50ms if the watchdog timer is enabled but not serviced within its timeout period. The $\overline{\text{RESET}}$ pulse width can be adjusted as shown in Table 1.
16	16	RESET	RESET is an Active-High Output. It is the inverse of $\overline{\text{RESET}}$.

Pin Description (continued)

PIN		NAME	FUNCTION
MAX696	MAX697		
—	1	TEST	Used During Maxim Manufacture Only. Always ground this pin.
—	12	\overline{CE} OUT	\overline{CE} OUT goes low only when \overline{CE} IN is low and LL_{IN} is above 1.3V. See Figure 5.
—	13	\overline{CE} IN	The Input to the \overline{CE} Gating Circuit. Connect to GND or V_{OUT} if not used.

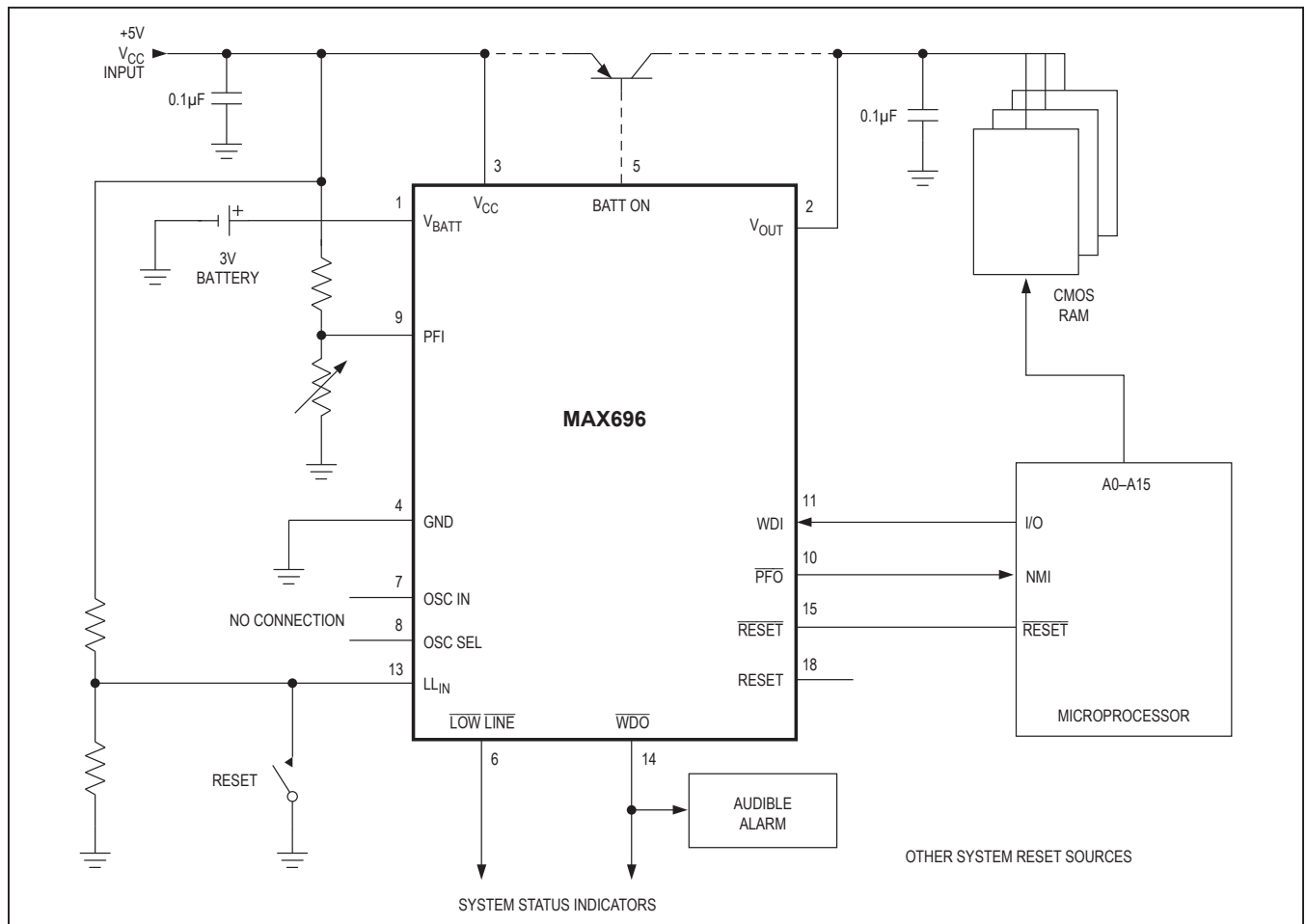

Figure 1. MAX696 Typical Application

Typical Applications

MAX696

A typical connection for the MAX696 is shown in Figure 1. CMOS RAM is powered from V_{OUT} . V_{OUT} is internally connected to V_{CC} when power is present, or to V_{BATT} when V_{CC} is less than the battery voltage. V_{OUT} can supply 50mA from V_{CC} , but if more current is required, an external pnp transistor can be added. When V_{CC} is higher than V_{BATT} , the BATT ON output goes

low, providing 7mA of base drive for the external transistor. When V_{CC} is lower than V_{BATT} , an internal 200Ω MOSFET connects the backup battery to V_{OUT} . The quiescent current in the battery-backup mode is 1µA maximum when V_{CC} is between 0V and ($V_{BATT} - 700mV$).

Reset Output

A voltage detector monitors V_{CC} and generates a \overline{RESET} output to hold the microprocessor's RESET line low when LL_{IN} is below 1.3V. An internal monostable holds RESET

low for 50ms after LL_{IN} rises above 1.3V. This prevents repeated toggling of \overline{RESET} even if the V_{CC} power drops out and recovers with each power line cycle.

The crystal oscillator normally used to generate the clock for microprocessors takes several milliseconds to start. Since most microprocessors need several clock cycles to reset, \overline{RESET} must be held low until the microprocessor clock oscillator has started. The power-up \overline{RESET} pulse lasts 50ms to allow for this oscillator startup time. An inverted, active-high \overline{RESET} output is also supplied.

Power-Fail Detector

The MAX696 issues a nonmaskable interrupt (NMI) to the microprocessor when a power failure occurs. The power line is monitored by two external resistors connected to the power-fail input (PFI). When the voltage at PFI falls below 1.3V, the power-fail output (\overline{PFO}) drives the processor's NMI input low. An earlier power-fail warning can be generated if the unregulated DC input of the regulator is available for monitoring.

Watchdog Timer

The microprocessor drives the watchdog input (WDI) with an I/O line. When OSC IN and OSC SEL are unconnected, the microprocessor must toggle the WDI pin once every 1.6 seconds to verify proper software execution. If a hardware or software failure occurs so that WDI is not toggled, the MAX696 will issue a 50ms \overline{RESET} pulse after 1.6 seconds. This typically restarts the microprocessor's power-up routine. A new \overline{RESET} pulse is issued every 1.6 seconds until WDI is again strobed.

The watchdog output (\overline{WDO}) goes low if the watchdog timer is not serviced within its timeout period. Once \overline{WDO} goes low, it remains low until a transition occurs at WDI while \overline{RESET} is high. The watchdog timer feature can be disabled by leaving WDI unconnected. OSC IN and OSC SEL also allow other watchdog timing options, as shown in Table 1 and Figure 7.

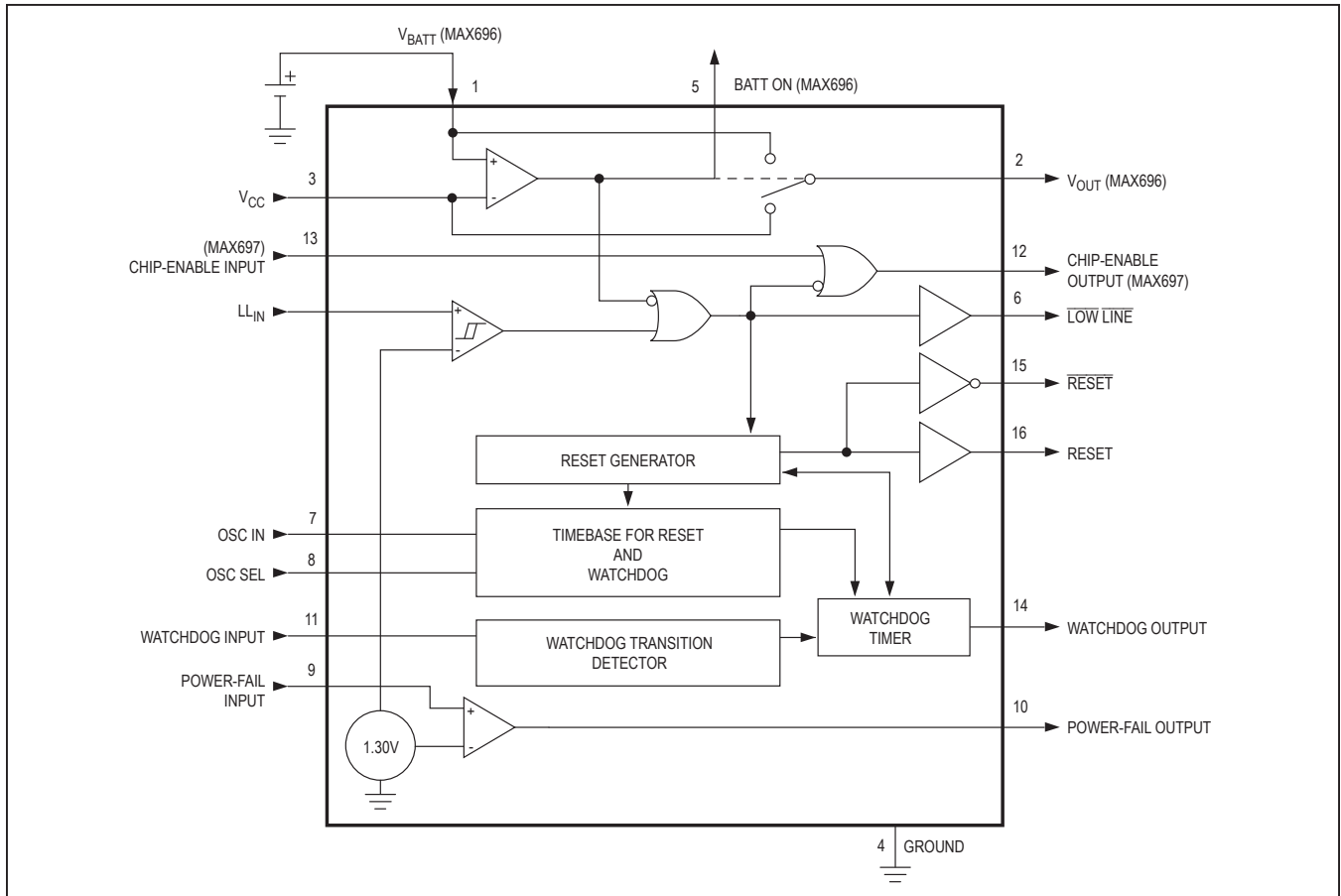

Figure 2. MAX696/MAX697 Block Diagram

MAX697

The MAX697 is nearly identical to the MAX696. The MAX697 lacks the battery-backup feature, so it does not have the V_{BATT} , V_{OUT} , or BATT ON pins. This allows the MAX697 to consume less than 250 microamperes, and it allows the inclusion of RAM write-protection pins. See Figure 2.

Detailed Description

Battery Switchover and V_{OUT} (MAX696)

Battery Switchover and V_{OUT} (MAX696) The battery-switchover circuit compares V_{CC} to the V_{BATT} input, and connects V_{OUT} to whichever is higher. Switchover occurs when V_{CC} is 50mV greater than V_{BATT} as V_{CC} falls, and when V_{CC} is 70mV more than V_{BATT} as V_{CC} rises (see Figure 3). The switchover comparator has 20mV of hysteresis to prevent repeated, rapid switching if V_{CC} falls very slowly or remains nearly equal to the battery voltage.

When V_{CC} is higher than V_{BATT} , V_{CC} is internally switched to V_{OUT} with a low-saturation pnp transistor. V_{OUT} has 50mA output current capability. Use an external pnp pass transistor in parallel with the internal transistor

if the output current requirement at V_{OUT} exceeds 50mA or if a lower $V_{CC} - V_{OUT}$ voltage differential is desired. The BATT ON output can directly drive the base of the external transistor.

It should be noted that the MAX696 need only supply the average current drawn by the CMOS RAM if there is adequate filtering. Many RAM data sheets specify a 75mA maximum supply current, but this peak current spike lasts only 100ns. A 0.1 μ F bypass capacitor at V_{OUT} supplies the high instantaneous current, while V_{OUT} need only supply the average load current, which is much less. A capacitance of 0.1 μ F or greater must be connected to the V_{OUT} terminal to ensure stability.

A 200 Ω MOSFET connects the V_{BATT} input to V_{OUT} during battery backup. This MOSFET has very low input-to-output differential (dropout voltage) at the low current levels required for battery backup of CMOS RAM or other low-power CMOS circuitry. When V_{CC} equals V_{BATT} , the supply current is typically 12 μ A. When V_{CC} is between 0V and ($V_{BATT} - 700$ mV), the typical supply current is only 600nA (typ), 1 μ A (max).

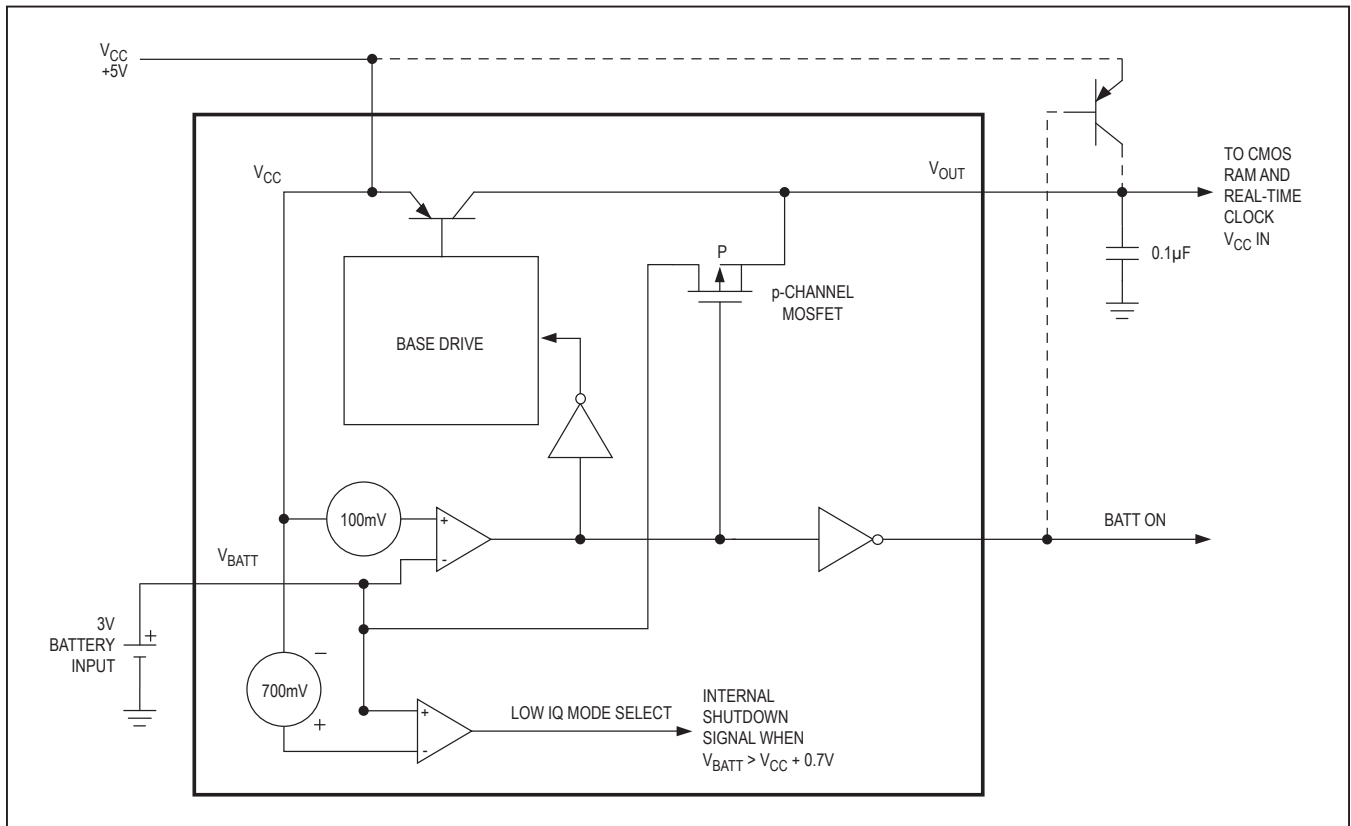

Figure 3. MAX696 Battery-Switchover Block Diagram

The MAX696 operates with battery voltages from 2.0V to 4.25V. The battery voltage should not be within 0.5V of V_{CC} , or switchover may occur. High-value capacitors, either standard electrolytic or the farad-size double-layer capacitors, can also be used for short-term memory backup. The capacitor charging voltage should include a diode to limit the fully charged voltage to approximately 0.5V less than V_{CC} . The charging resistor for rechargeable batteries should be connected to V_{OUT} since this eliminates the discharge path that exists if the resistor is connected to V_{CC} .

A small leakage current of typically 10nA (20nA max) flows out of the V_{BATT} terminal. This current varies with the amount of current that is drawn from V_{OUT} , but its polarity is such that the backup battery is always slightly charged, and is never discharged while V_{CC} is in its operating voltage range. This extends the shelf life of the backup battery by compensating for its self-discharge current. Also note that this current poses no problem when lithium batteries are used for backup since the maximum current (20nA) is safe for even the smallest lithium cells.

If the battery-switchover section is not used, connect V_{BATT} to GND and connect V_{OUT} to V_{CC} . Table 2 shows the state of the inputs and output in the lowpower battery-backup mode.

Reset Output

RESET is an active-low output that goes low whenever LL_{IN} falls below 1.3V. It remains low until LL_{IN} rises above 1.312V for 50ms. (See Figures 4 and 5.)

The guaranteed minimum and maximum low-line thresholds of the MAX696/MAX697 are 1.25V and 1.35V. The LL_{IN} comparator has approximately 12mV of hysteresis.

The response time of the reset voltage comparator is about 100µs. LL_{IN} should be bypassed to ensure that glitches do not activate the \overline{RESET} output.

\overline{RESET} also goes low if the watchdog timer is enabled and WDI remains either high or low longer than the watchdog timeout period. \overline{RESET} has an internal 3µA pullup, and can either connect to an open-collector reset bus or directly drive a CMOS gate without an external pullup resistor.

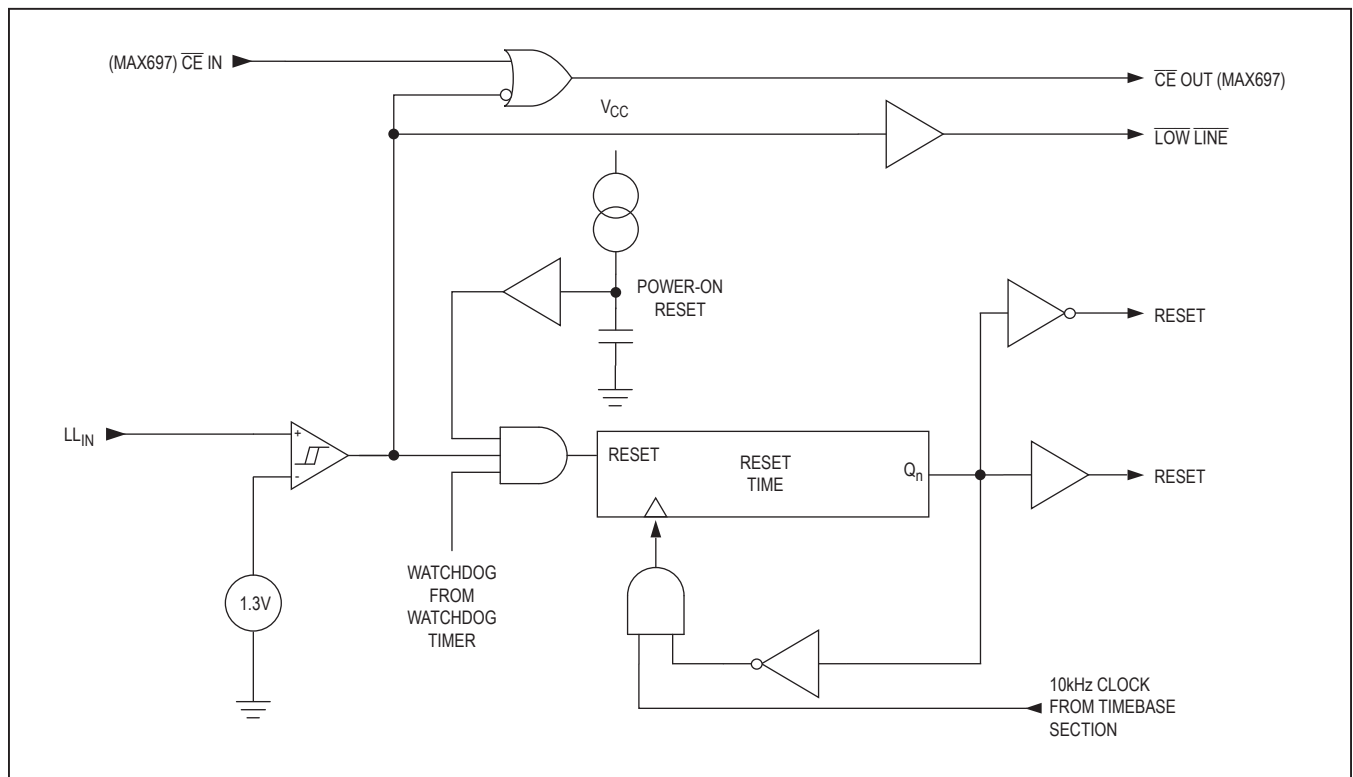

Figure 4. Reset Block Diagram

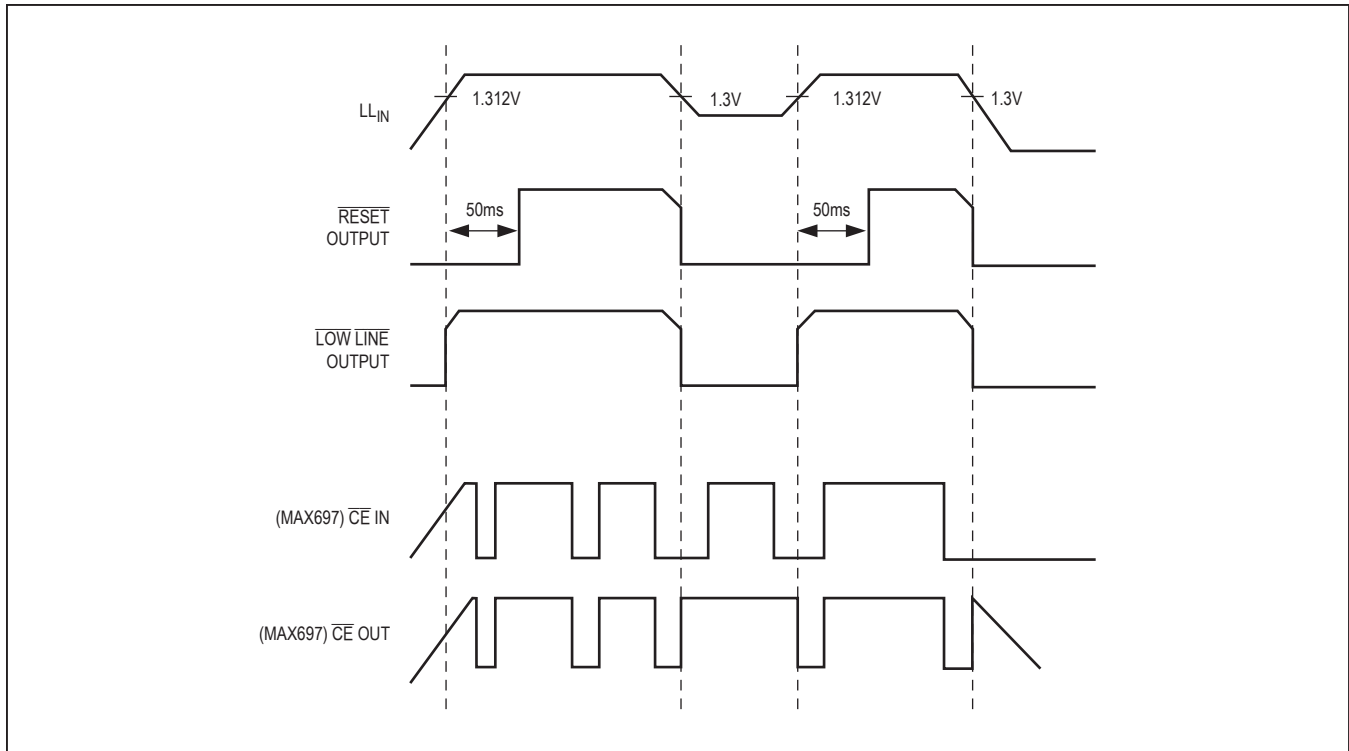

Figure 5. MAX697 Reset Timing

CE Gating and RAM Write Protection

The MAX697 uses two pins to control the \overline{CE} or \overline{WRITE} inputs of CMOS RAMs. When LL_{IN} is $> 1.3V$, \overline{CE} OUT is a buffered replica of \overline{CE} IN, with a 50ns propagation delay. If LL_{IN} input falls below 1.3V (1.2V min, 1.4V max), an internal gate forces \overline{CE} OUT high, independent of \overline{CE} IN. The \overline{CE} output is also forced high when V_{CC} is less than V_{BATT} . (See Figure 4.)

\overline{CE} OUT typically drives the \overline{CE} , \overline{CS} , or \overline{WRITE} input of battery backed up CMOS RAM. This ensures the integrity of the data in memory by preventing write operations when V_{CC} is at an invalid level. Similar protection of EEPROMs can be achieved by using the \overline{CE} OUT to drive the \overline{STORE} or \overline{WRITE} inputs of an EEPROM, EAROM, or NOVRAM.

If the 50ns typical propagation delay of \overline{CE} OUT is too long, connect \overline{CE} IN to GND and use the resulting \overline{CE} OUT to control a high-speed external logic gate. A second alternative is to AND the LOW LINE output with the \overline{CE} or \overline{WR} signal. An external logic gate and the RESET output of the MAX696/MAX697 can also be used for CMOS RAM write protection.

1.25V Comparator and Power-Fail Warning

The power-fail input (PFI) is compared to an internal 1.3V reference. The power-fail output (PFO) goes low when the voltage at PFI is less than 1.3V. Typically PFI is driven by an external voltage-divider that senses either the unregulated DC input to the system's V_{CC} regulator or the regulated output. The voltage-divider ratio can be chosen so the voltage at PFI falls below 1.3V several milliseconds before the LL_{IN} falls below 1.3V. PFO is normally used to interrupt the microprocessor so that data can be stored in RAM before LL_{IN} falls below 1.3V and the RESET output goes low.

The power-fail detector can also monitor the backup battery to warn of a low-battery condition. To conserve battery power, the power-fail detector comparator is turned off and \overline{PFO} is forced low when V_{CC} is lower than the V_{BATT} input voltage.

Watchdog Timer and Oscillator

The watchdog circuit monitors the activity of the microprocessor. If the microprocessor does not toggle the watchdog input (WDI) within the selected timeout period, a 50ms RESET pulse is generated. Since many systems cannot service the watchdog timer immediately after a reset, the MAX696/MAX697 have a longer timeout period after

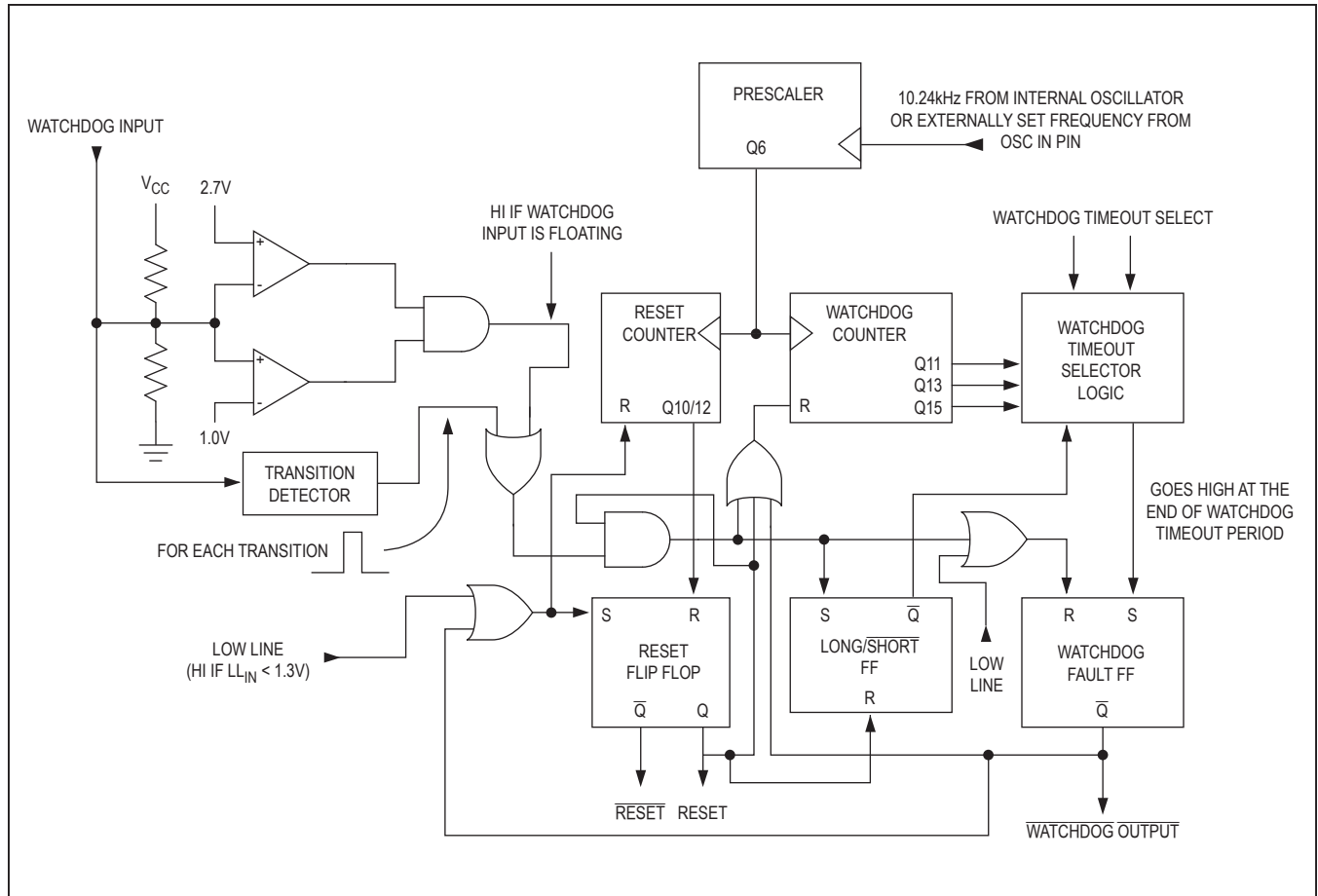

Figure 6. Watchdog Timer Block Diagram

a reset is issued. The normal timeout period becomes effective following the first transition of WDI after $\overline{\text{RESET}}$ has gone high. The watchdog timer is restarted at the end of reset, whether the reset was caused by lack of activity on WDI or by LL_{IN} falling below 1.3V. If WDI remains either high or low, reset pulses will be issued every 1.6s. The watchdog monitor can be deactivated by floating the watchdog input (WDI).

The watchdog output ($\overline{\text{WDO}}$) goes low if the watchdog timer times out, and it remains low until set high by the next transition on the watchdog input. $\overline{\text{WDO}}$ is also set high when LL_{IN} goes below 1.3V. The watchdog timeout period defaults to 1.6s and the reset pulse width defaults to 50ms. The MAX696 and MAX697 allow these times to be adjusted per Table 1.

The internal oscillator is enabled when OSC SEL is high or floating. In this mode, OSC IN selects between the 1.6s and 100ms watchdog timeout periods. In either case, immediately after a reset, the timeout period is 1.6s. This gives the microprocessor time to reinitialize the system. WD transmissions while $\overline{\text{RESET}}$ is low are ignored. If OSC IN is low, then the 100ms watchdog period becomes effective after the first transition of WDI. The software should be written so the I/O port driving WDI is left in its power-up reset state until the initialization routines are completed and the microprocessor is able to toggle WDI at the minimum 70ms watchdog timeout period.

Applications Information

Adding Hysteresis to the Power-Fail Comparator

Since the power-fail comparator circuit is noninverting, hysteresis can be added by connecting a resistor between the $\overline{\text{PFO}}$ output and the PFI input as shown in Figure 7. When $\overline{\text{PFO}}$ is low, resistor R3 sinks current from the summing junction at the PFI pin. When $\overline{\text{PFO}}$ is high, the series combination of R3 and R4 source current into the PFI summing junction.

Alternate Watchdog Input Drive Circuits

The watchdog feature can be enabled and disabled under program control by driving WDI with a three-state

buffer (Figure 8). The drawback to this circuit is that a software fault may erroneously three-state the buffer, thereby preventing the MAX696/MAX697 from detecting that the microprocessor is no longer working. In most cases, a better method is to extend the watchdog period rather than disabling the watchdog. See Figure 9. When the control input is high, the OSC SEL pin is low and the watchdog timeout is set by the external capacitor. A 0.01 μF capacitor sets a watchdog timeout delay of 100s. When the control input is low, the OSC SEL pin is driven high, selecting the internal oscillator. The 100ms or the 1.6s period is chosen, depending on which diode in Figure 9 is used.

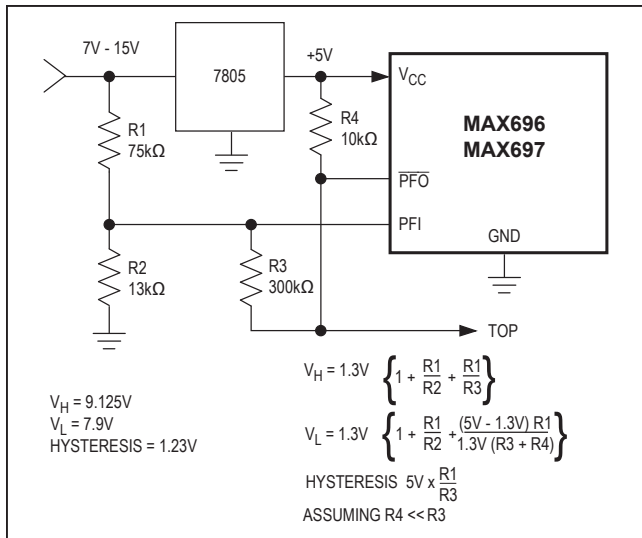

Figure 7. Adding Hysteresis to the Power-Fail Voltage Comparator

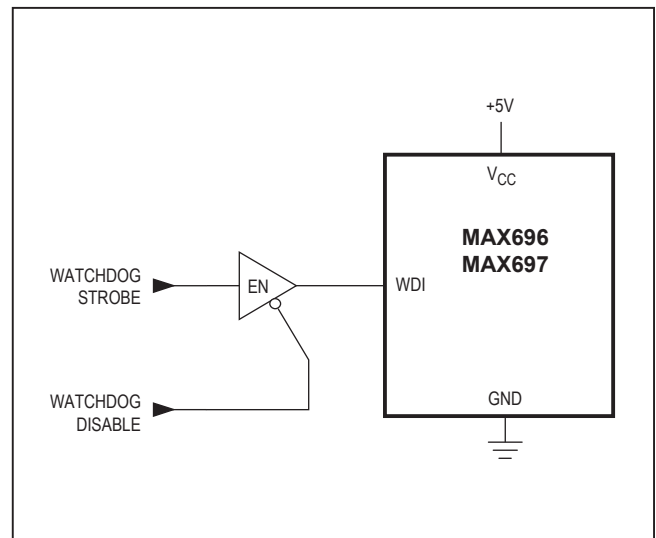

Figure 8. Disabling the Watchdog Under Program Control

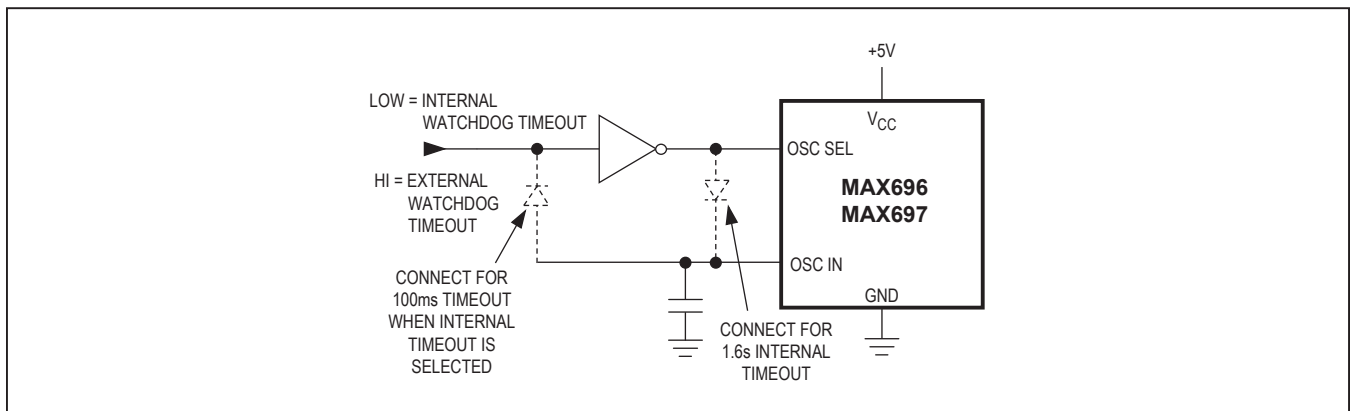

Figure 9. Selecting Internal or External Watchdog Timeout

Table 1. MAX696 and MAX697 Reset Pulse Width and Watchdog Timeout Selections (Notes 1, 2)

OSC SEL (Note 3)	OSC IN	WATCHDOG TIMEOUT PERIOD		RESET TIMEOUT PERIOD
		NORMAL	IMMEDIATELY AFTER RESET	
Low	External Clock Input	1024 clocks	4096 clocks	512 clocks
Low	External Capacitor	400ms/47pF x C	1.6s/47pF x C	200ms/47pF x C
High/Floating	Low	100ms	1.6s	50ms
High/Floating	Floating	1.6s	1.6s	50ms

Note 1: When the MAX696/MAX697 OSC SEL pin is low, OSC IN can be driven by an external clock signal, or an external capacitor can be connected between OSC IN and GND. The nominal internal oscillator frequency is 10.24kHz. The nominal oscillator frequency with external capacitor is $f_{OSC} \text{ (Hz)} = 184,000/C_{OSC} \text{ (pF)}$.

Note 2: See the *Electrical Characteristics* table for minimum and maximum timing values.

Note 3: High for the OSC SEL pin should be connected to V_{OUT} , not V_{CC} (on the MAX696).

Table 2. Input and Output Status in Battery-Backup Mode

I/O	STATUS
V_{BATT} , V_{OUT}	V_{BATT} is connected to V_{OUT} with an internal MOSFET (MAX696 only).
\overline{RESET}	Logic-low.
RESET	Logic-high. The open-circuit output voltage is equal to V_{OUT} .
$\overline{LOW LINE}$	Logic-low.
BATT ON	Logic-high (MAX696 only).
WDI	WDI is internally disconnected from its internal pullup and does not source or sink current as long as its input voltage is between GND and V_{OUT} . The input voltage does not affect supply current.
\overline{WDO}	Logic-high.
PFI	The power-fail comparator is turned off and the power-fail input voltage has no effect on the power-fail output.
\overline{PFO}	Logic-low.
$\overline{CE IN}$	$\overline{CE IN}$ is internally disconnected from its internal pullup and does not source or sink current as long as its input voltage is between GND and V_{OUT} . The input voltage does not affect supply current (MAX696 only).
$\overline{CE OUT}$	Logic-high (MAX697 only).
OSC IN	OSC IN is ignored.
OSC SEL	OSC SEL is ignored.
V_{CC}	Approximately 12 μ A is drawn from the V_{BATT} input when V_{CC} is between ($V_{BATT} + 100\text{mV}$) and ($V_{BATT} - 700\text{mV}$). The supply current is 1 μ A maximum when V_{CC} is less than $V_{BATT} - 700\text{mV}$.

Typical Operating Circuit

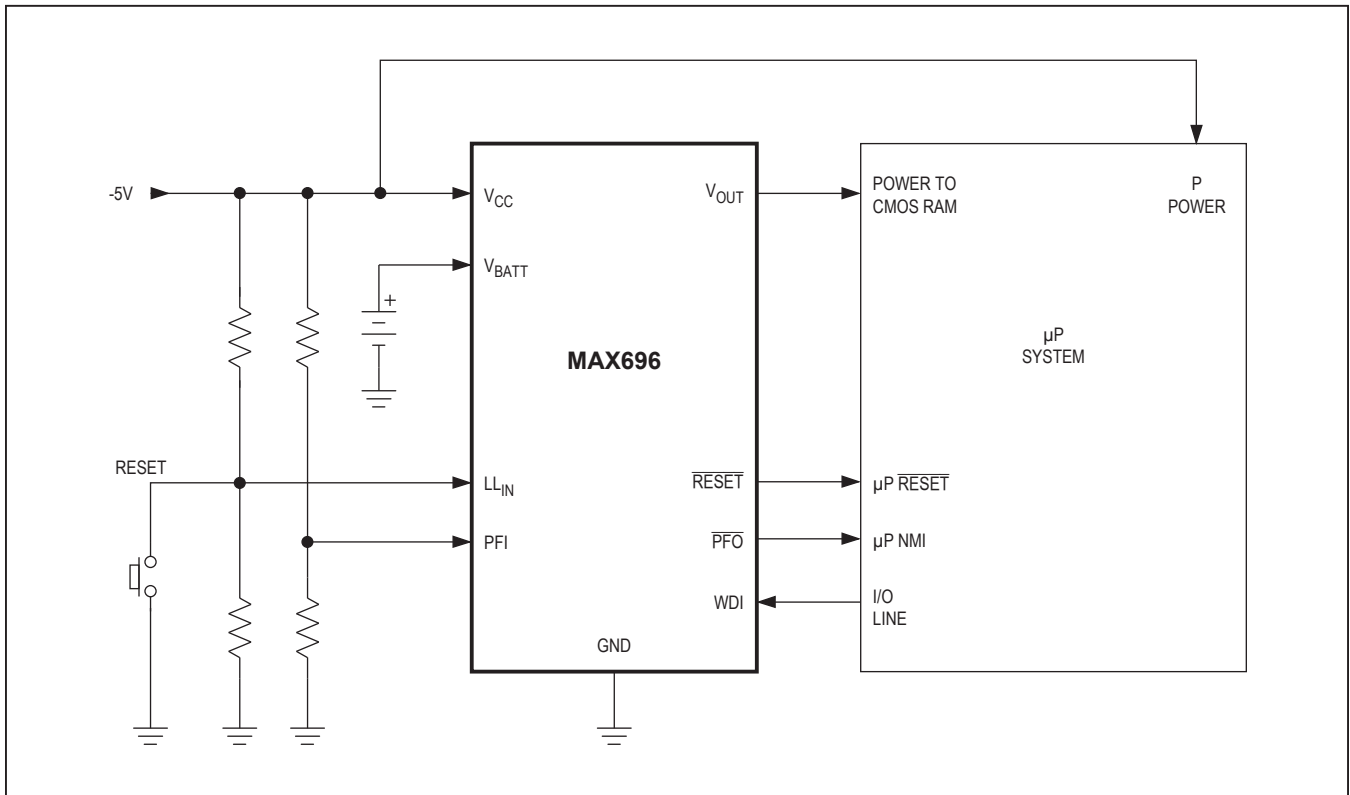

Ordering Information

PART	TEMP RANGE	PIN-PACKAGE
MAX697C/D	0°C to +70°C	Dice
MAX697CPE	0°C to +70°C	16 PDIP
MAX697CWE	0°C to +70°C	16 Wide SO
MAX697EPE	-40°C to +85°C	16 PDIP
MAX697EJE	-40°C to +85°C	16 CERDIP
MAX697EWE	-40°C to +85°C	16 Wide SO
MAX697MJE	-55°C to +125°C	16 CERDIP

Devices in PDIP and SO packages are available in both leaded and lead(Pb)-free packaging. Specify lead free by adding the + symbol at the end of the part number when ordering. Lead free not available for CERDIP package.

Pin Configurations (continued)

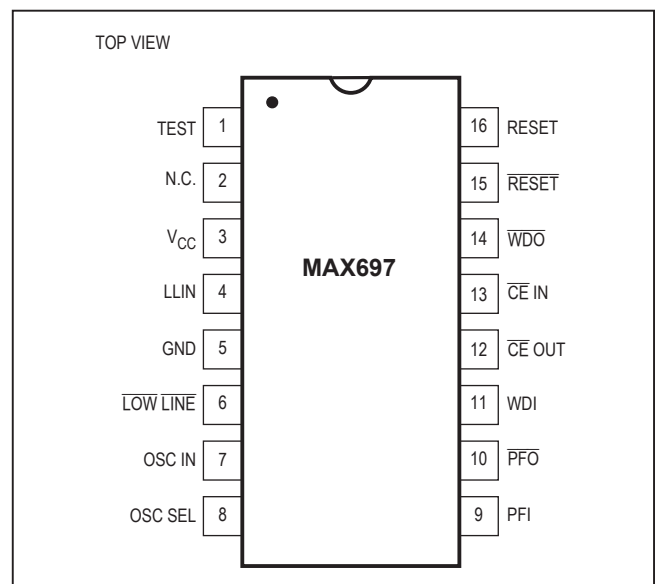

Chip Topography

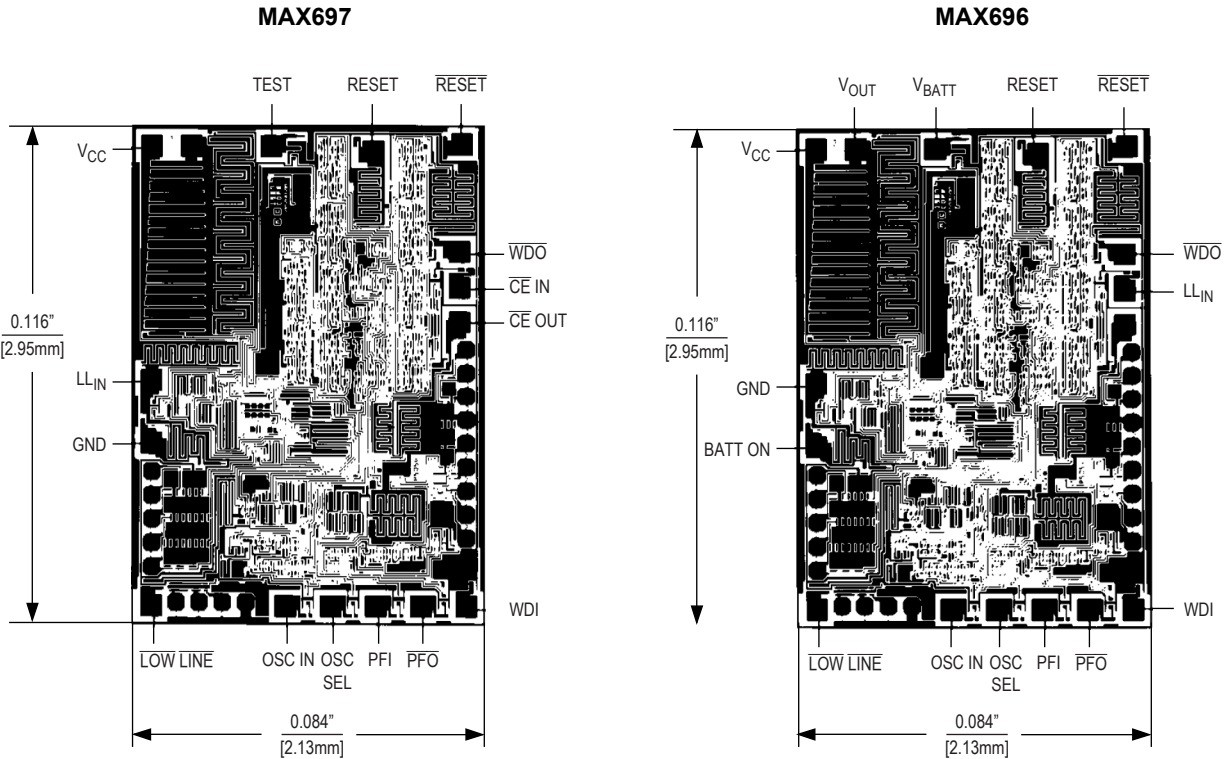

Package Information

For the latest package outline information and land patterns (footprints), go to www.maximintegrated.com/packages. Note that a “+”, “#”, or “-” in the package code indicates RoHS status only. Package drawings may show a different suffix character, but the drawing pertains to the package regardless of RoHS status.

PACKAGE TYPE	PACKAGE CODE	OUTLINE NO.	LAND PATTERN NO.
16 CERDIP	J16-3	21-0045	—
16 PDIP	P16+1	21-0043	—
16 Wide SO	W16+1	21-0042	90-0107

Revision History

REVISION NUMBER	REVISION DATE	DESCRIPTION	PAGES CHANGED
4	5/14	No <i>I</i> V OPNs; removed automotive reference from <i>Applications</i> section	1
5	7/14	Corrected typos in Figures 4, 5; updated <i>Reset Output</i> section	9, 10

For pricing, delivery, and ordering information, please contact Maxim Direct at 1-888-629-4642, or visit Maxim Integrated's website at www.maximintegrated.com.

Maxim Integrated cannot assume responsibility for use of any circuitry other than circuitry entirely embodied in a Maxim Integrated product. No circuit patent licenses are implied. Maxim Integrated reserves the right to change the circuitry and specifications without notice at any time. The parametric values (min and max limits) shown in the Electrical Characteristics table are guaranteed. Other parametric values quoted in this data sheet are provided for guidance.

Компания «Океан Электроники» предлагает заключение долгосрочных отношений при поставках импортных электронных компонентов на взаимовыгодных условиях!

Наши преимущества:

- Поставка оригинальных импортных электронных компонентов напрямую с производств Америки, Европы и Азии, а так же с крупнейших складов мира;
- Широкая линейка поставок активных и пассивных импортных электронных компонентов (более 30 млн. наименований);
- Поставка сложных, дефицитных, либо снятых с производства позиций;
- Оперативные сроки поставки под заказ (от 5 рабочих дней);
- Экспресс доставка в любую точку России;
- Помощь Конструкторского Отдела и консультации квалифицированных инженеров;
- Техническая поддержка проекта, помощь в подборе аналогов, поставка прототипов;
- Поставка электронных компонентов под контролем ВП;
- Система менеджмента качества сертифицирована по Международному стандарту ISO 9001;
- При необходимости вся продукция военного и аэрокосмического назначения проходит испытания и сертификацию в лаборатории (по согласованию с заказчиком);
- Поставка специализированных компонентов военного и аэрокосмического уровня качества (Xilinx, Altera, Analog Devices, Intersil, Interpoint, Microsemi, Actel, Aeroflex, Peregrine, VPT, Syfer, Eurofarad, Texas Instruments, MS Kennedy, Miteq, Cobham, E2V, MA-COM, Hittite, Mini-Circuits, General Dynamics и др.);

Компания «Океан Электроники» является официальным дистрибьютором и эксклюзивным представителем в России одного из крупнейших производителей разъемов военного и аэрокосмического назначения «JONHON», а так же официальным дистрибьютором и эксклюзивным представителем в России производителя высокотехнологичных и надежных решений для передачи СВЧ сигналов «FORSTAR».



JONHON

«JONHON» (основан в 1970 г.)

Разъемы специального, военного и аэрокосмического назначения:

(Применяются в военной, авиационной, аэрокосмической, морской, железнодорожной, горно- и нефтедобывающей отраслях промышленности)

«FORSTAR» (основан в 1998 г.)

ВЧ соединители, коаксиальные кабели, кабельные сборки и микроволновые компоненты:

(Применяются в телекоммуникациях гражданского и специального назначения, в средствах связи, РЛС, а так же военной, авиационной и аэрокосмической отраслях промышленности).



Телефон: 8 (812) 309-75-97 (многоканальный)

Факс: 8 (812) 320-03-32

Электронная почта: ocean@oceanchips.ru

Web: <http://oceanchips.ru/>

Адрес: 198099, г. Санкт-Петербург, ул. Калинина, д. 2, корп. 4, лит. А