

## Description

IS31FL3199 is a 9-channel light effect LED driver which features two-dimensional auto breathing mode and an audio modulated display mode. It has One Shot Programming mode and PWM Control mode for RGB lighting effects. The maximum output current can be adjusted in 8 levels (5mA~40mA).

The IS31FL3199 includes an audio modulated display mode, wherein the brightness of LED can be modulated by audio signal. There is a cascade pin for the synchronization of two chips.

## Features

- Supply voltage range from 3.0V to 5.5V
- I2C interface, automatic address increment function
- Three groups RGB, single color LED breathing system-free pre-established pattern
- 9 independently controlled automatic and semiautomatic breathing system-free pre-established pattern
- 9 independently controlled outputs of 256 PWM steps
- 8 levels programmable output current
- Audio mode with AGC function
- Package: QFN-20, 3mm x 3mm

## Quick Start



Figure 1: Photo of IS31FL3199 Evaluation Board

## Recommended Equipment

- 5.0V, 2A power supply
- Audio source( i.e. MP3 player, Notebook PC, etc)
- 8Ω speaker

## Absolute Maximum Ratings

- ≤ 5.5V power supply

**Caution: Do not exceed the above conditions; otherwise the board will be damaged.**

## Procedure

The IS31FL3199 evaluation board is fully assembled and tested. Follow the steps listed below to verify board operation.

**Caution: Do not turn on the power supply until all connections are completed.**

- 1) Connect an 8Ω speaker to the “SPK” connector.
- 2) Connect the audio source to the “AUDIO IN” connector.
- 3) Connect the ground terminal of the power supply to the GND and the positive terminal to the VCC. Or connect the DC power to the connector (DC IN).
- 4) Turn on the power supply and pay attention to the supply current. If the current exceeds 1A, please check for circuit fault.
- 5) Turn on the audio signal.
- 6) Modulation of the audio signal utilized to obtain better sound output performance

## Evaluation Board Ordering Information

Part No.	IC Package
IS31FL3199-QFLS2-EB	QFN-20, Lead-free

Table1: Ordering Information

**For pricing, delivery, and ordering information, please contacts ISSI’s analog marketing team at [analog\\_mkt@issi.com](mailto:analog_mkt@issi.com) or (408) 969-6600.**

## Evaluation Board Operation

The IS31FL3199 evaluation board has five display modes. Press MODE button to switch configurations.

- 1) Default Mode: 9 LEDs perform breath dimming effect.
- 2) 3 LEDs in one group: Single color breathing dimming. Each group performs dimming one by one, then three groups dim together.
- 3) 3 LEDs in one group: auto color changing following the rhythm of the input music.
- 4) 9 LEDs breathing dimming one followed by the other.
- 5) Breath dimming synchronized with the rhythm of the input music.

**Note:**

**IS31FL3199 solely controls the FxLED function on the evaluation board.**

## Software Control

Please refer to the integrated program.

JP1 default setting is close circuit. If it is set to open, the on-board MCU will stop working. The I2C pins are set to High Impedance. External I2C signals can be connected to TP3 to control the IS31FL3199 LED driver.

*Please refer to the datasheet for how to control the IS31FL3199.*

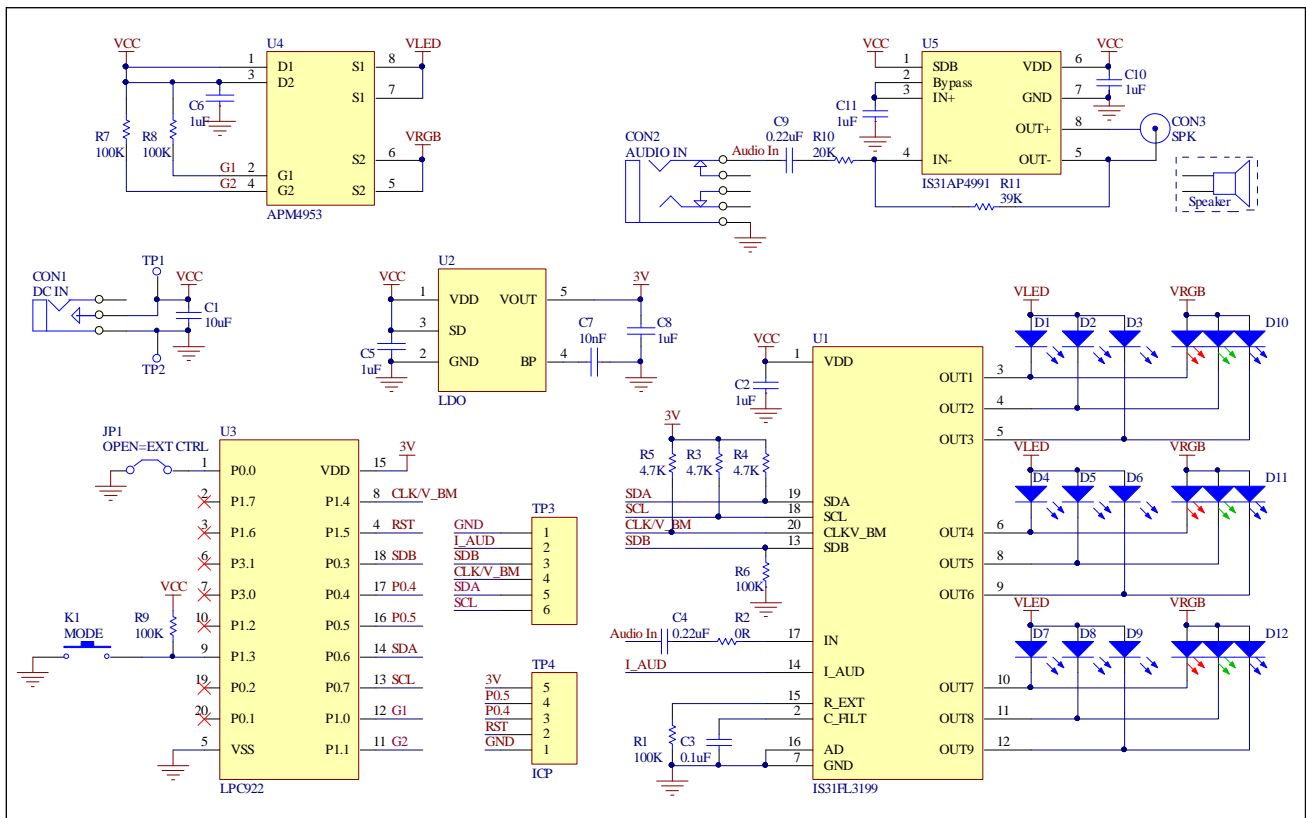

Figure 2: IS31FL3199 Application Schematic

**Bill of Materials**

Name	Symbol	Description	Qty	Supplier	Part No.
LED Driver	U1	9CH FxLED Driver	1	ISSI	IS31FL3199
LDO	U2	Low-dropout Regulator	1	PAM	PAM3101
MCU	U3	Microcontroller	1	NXP	LPC922
PMOS	U4	Dual PMOS	1	ANPEC	APM4953
Audio Amplifier	U5	Class AB Audio Amplifier	1	ISSI	IS31AP4991
Diodes	D1,D5,D8	Diode, LED Blue, SMD	3	Everlight	19-217/BHC-ZL 1M2RY/3T
Diodes	D2,D9	Diode, LED Red, SMD	2	Everlight	19-217/BHC-ZL 1M2RY/3T
Diodes	D3,D6	Diode, LED Green, SMD	2	Everlight	19-217/BHC-ZL 1M2RY/3T
Diodes	D4,D7	Diode, LED White, SMD	2	Everlight	19-217/BHC-ZL 1M2RY/3T
Diodes	D10~D12	Diode, LED RGB, SMD	3	Everlight	99-235/RGBC/T R8
Resistors	R1,R6,R7,R8,R9	RES,100k,1/16W,±5%,SMD	5		
Resistor	R2	RES,0R,1/16W,±5%,SMD	1		
Resistors	R3~R5	RES,4.7k,1/16W,±5%,SMD	3		
Resistor	R10	RES,20k,1/16W,±5%,SMD	1		
Resistor	R11	RES,39k,1/16W,±5%,SMD	1		
Capacitor	C1	CAP,10μF,16V,±20%,SMD	1		
Capacitors	C2,C5,C6,C8,C10, C11	CAP, 1μF,16V,±20%,SMD	6		
Capacitors	C3	CAP,0.1μF,16V,±20%,SMD	1		
Capacitor	C4	CAP,0.22μF,16V,±20%,SMD	1		
Capacitor	C7	CAP,10nF,16V,±20%,SMD	1		
Button	K1	Button SMD	1		

*Table 2: Bill of Materials, refer to Figure 2 above.*

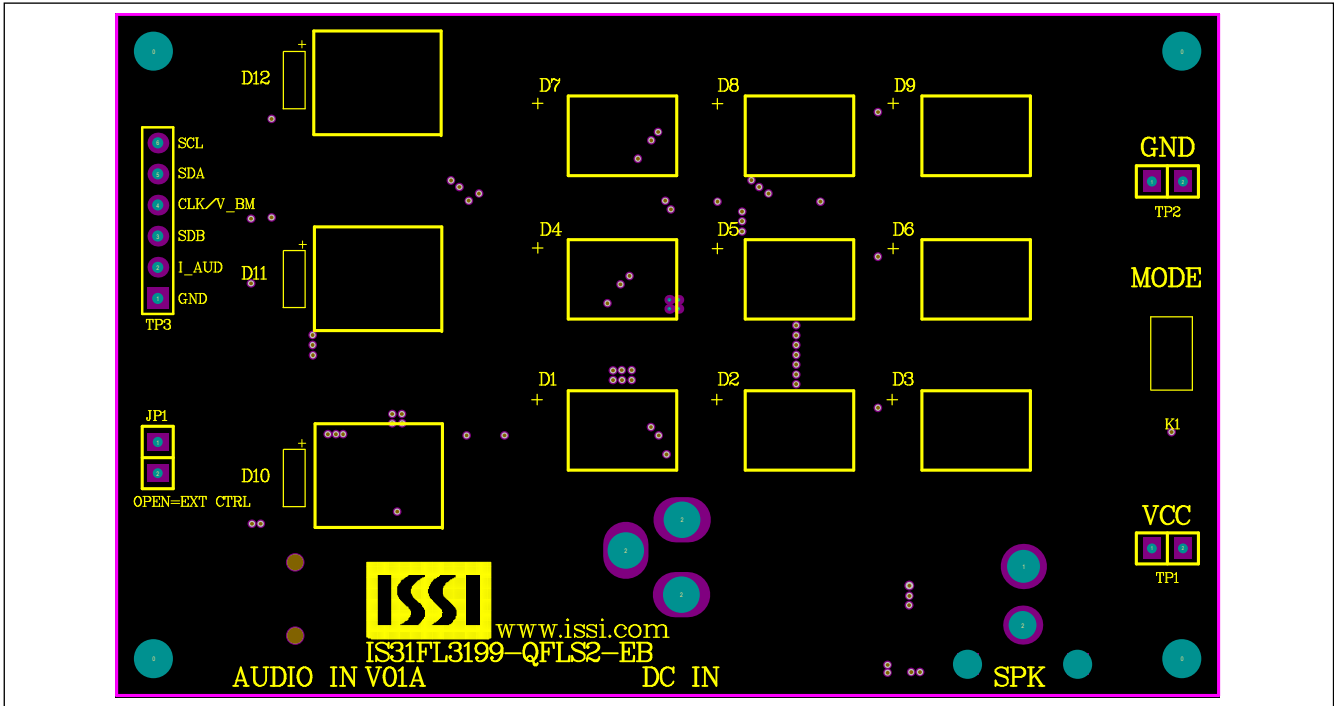

Figure 3: Board Component Placement Guide -Top Layer

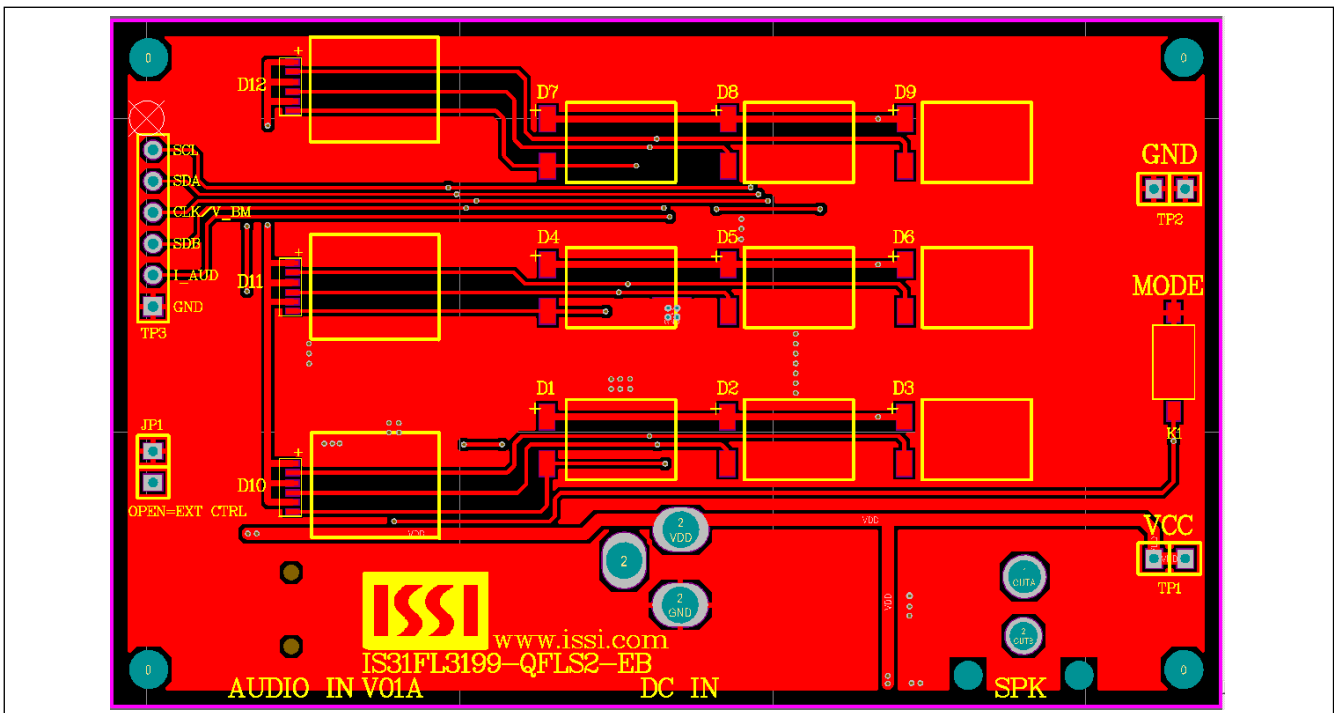

Figure 4: Board PCB Layout- Top Layer

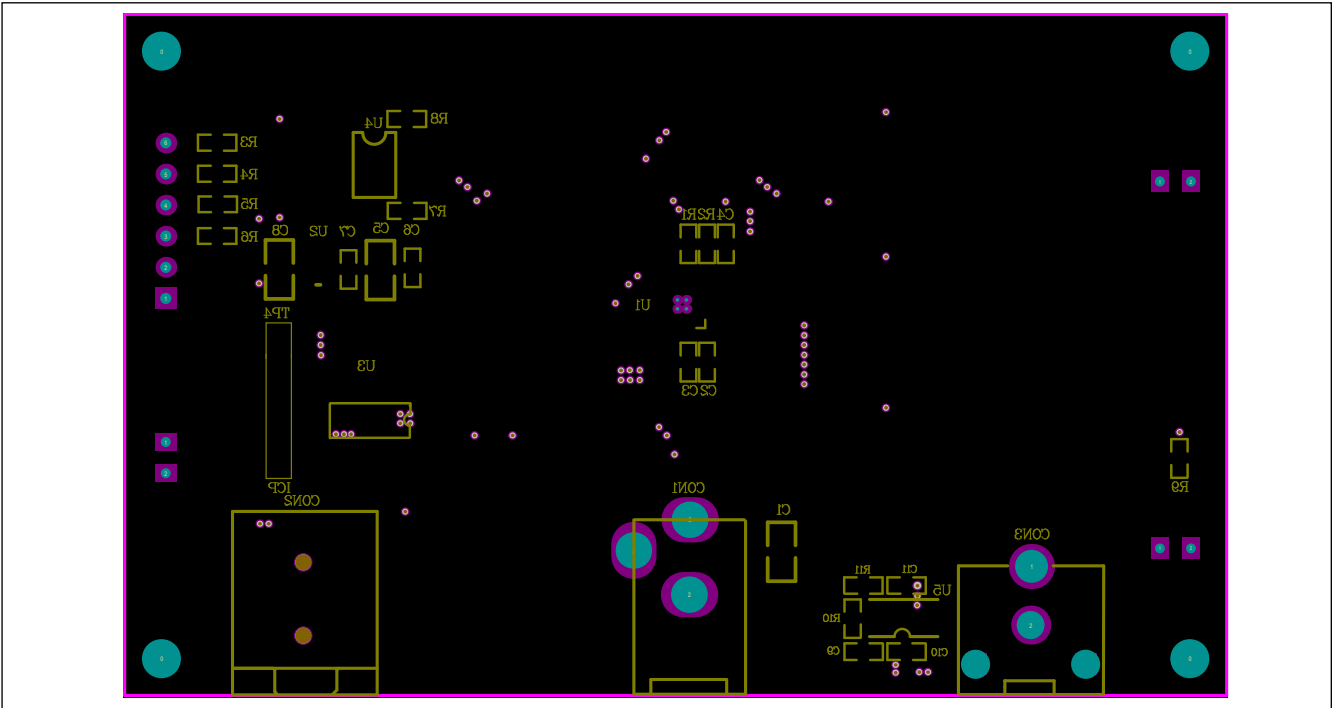

Figure 5: Board Component Placement Guide -Bottom Layer

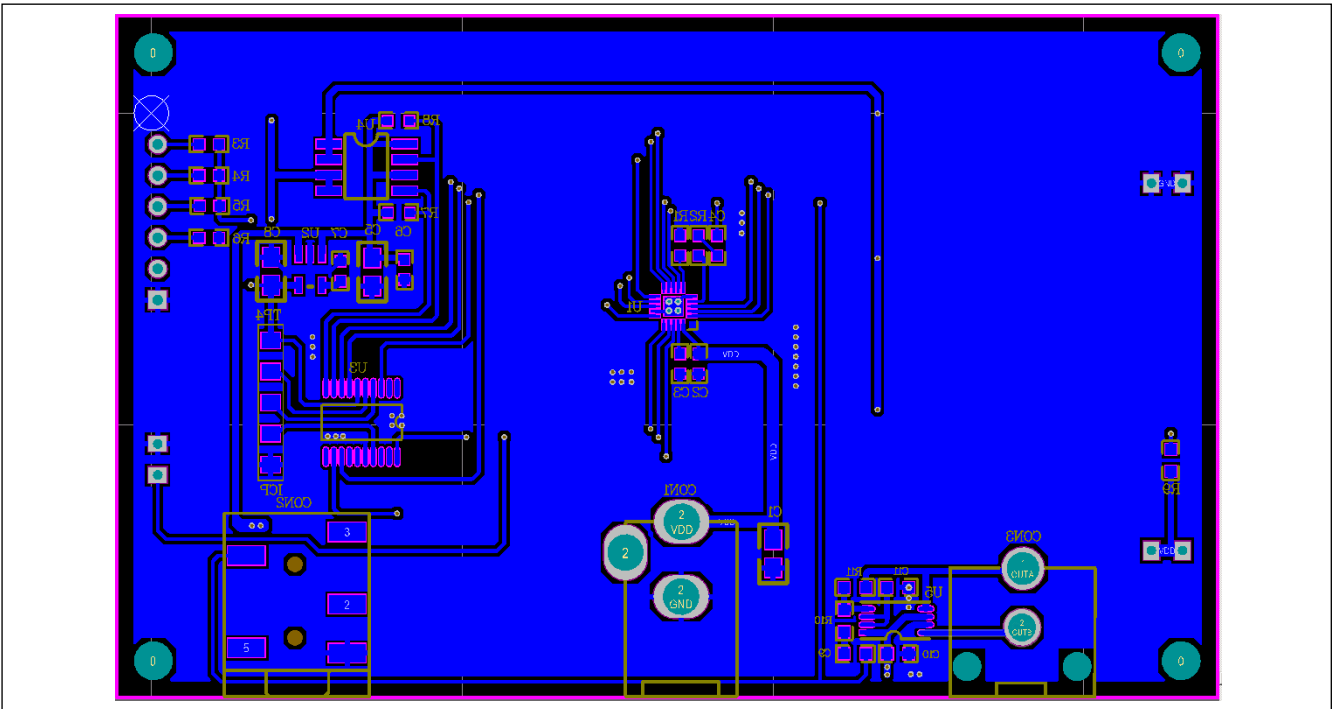

Figure 6: Board PCB Layout-Bottom Layer



## **IS31FL3199 9-Channel Light Effect LED Driver Evaluation Board Guide**

---

Copyright © 2011 Integrated Silicon Solution, Inc. All rights reserved. ISSI reserves the right to make changes to this specification and its products at any time without notice. ISSI assumes no liability arising out of the application or use of any information, products or services described herein. Customers are advised to obtain the latest version of this device specification before relying on any published information and before placing orders for products.

Integrated Silicon Solution, Inc. does not recommend the use of any of its products in life support applications where the failure or malfunction of the product can reasonably be expected to cause failure of the life support system or to significantly affect its safety or effectiveness. Products are not authorized for use in such applications unless Integrated Silicon Solution, Inc. receives written assurance to its satisfaction, that:

- a.) the risk of injury or damage has been minimized;
- b.) the user assume all such risks; and
- c.) potential liability of Integrated Silicon Solution, Inc is adequately protected under the circumstances

Компания «Океан Электроники» предлагает заключение долгосрочных отношений при поставках импортных электронных компонентов на взаимовыгодных условиях!

Наши преимущества:

- Поставка оригинальных импортных электронных компонентов напрямую с производств Америки, Европы и Азии, а так же с крупнейших складов мира;
- Широкая линейка поставок активных и пассивных импортных электронных компонентов (более 30 млн. наименований);
- Поставка сложных, дефицитных, либо снятых с производства позиций;
- Оперативные сроки поставки под заказ (от 5 рабочих дней);
- Экспресс доставка в любую точку России;
- Помощь Конструкторского Отдела и консультации квалифицированных инженеров;
- Техническая поддержка проекта, помощь в подборе аналогов, поставка прототипов;
- Поставка электронных компонентов под контролем ВП;
- Система менеджмента качества сертифицирована по Международному стандарту ISO 9001;
- При необходимости вся продукция военного и аэрокосмического назначения проходит испытания и сертификацию в лаборатории (по согласованию с заказчиком);
- Поставка специализированных компонентов военного и аэрокосмического уровня качества (Xilinx, Altera, Analog Devices, Intersil, Interpoint, Microsemi, Actel, Aeroflex, Peregrine, VPT, Syfer, Eurofarad, Texas Instruments, MS Kennedy, Miteq, Cobham, E2V, MA-COM, Hittite, Mini-Circuits, General Dynamics и др.);

Компания «Океан Электроники» является официальным дистрибьютором и эксклюзивным представителем в России одного из крупнейших производителей разъемов военного и аэрокосмического назначения «JONHON», а так же официальным дистрибьютором и эксклюзивным представителем в России производителя высокотехнологичных и надежных решений для передачи СВЧ сигналов «FORSTAR».



## JONHON

«JONHON» (основан в 1970 г.)

Разъемы специального, военного и аэрокосмического назначения:

(Применяются в военной, авиационной, аэрокосмической, морской, железнодорожной, горно- и нефтедобывающей отраслях промышленности)

«FORSTAR» (основан в 1998 г.)

ВЧ соединители, коаксиальные кабели,  
кабельные сборки и микроволновые компоненты:

(Применяются в телекоммуникациях гражданского и специального назначения, в средствах связи, РЛС, а так же военной, авиационной и аэрокосмической отраслях промышленности).



Телефон: 8 (812) 309-75-97 (многоканальный)

Факс: 8 (812) 320-03-32

Электронная почта: [ocean@oceanchips.ru](mailto:ocean@oceanchips.ru)

Web: <http://oceanchips.ru/>

Адрес: 198099, г. Санкт-Петербург, ул. Калинина, д. 2, корп. 4, лит. А