

LT3506A and LT3506 Dual Monolithic 1.6A Step- Down Switching Regulator

DESCRIPTION

Demonstration circuit 958 is a Dual Monolithic 1.6A Step-Down Switching Regulator featuring the LT3506A and LT3506. The top half of the board features the LT3506A circuit. The bottom half of the board features the LT3506 circuit. These two circuits are totally independent on the demo board. The main difference between the two circuits is the switching frequency. The switching frequency of the LT3506A circuit is 1.1MHz. The LT3506 switching frequency is 575KHz. Higher switching frequency allows smaller components in a given application. Lower switching frequency gives higher efficiency and allows a circuit to operate at a lower duty cycle.

The LT3506A circuit takes a 6.8V to 25V input and generates a 5V and a 3.3V output, both at 1.6A. The LT3506 circuit takes a 3.6V to 21V input and generates a 1.8V and a 1.2V output, both at 1.6A. The wide input voltage of the LT3506A and the LT3506, 3.6V to 25V, accepts a variety of power

sources, from lead-acid batteries and 5V rails to unregulated wall adapters and distributed power supplies. The output voltage of both the LT3506A and LT3506 can be as low as 0.8V.

The LT3506 high switching frequency and current mode control allow the use of small, low profile surface mount components. The circuit is stable with ceramic capacitors. The low ESR of a ceramic capacitor and high switching frequency results in very low, predictable output ripple.

The LT3506 datasheet gives complete description of the part, operation and application information. The datasheet must be read in conjunction with this quick start guide for working on or modifying the demo circuit 958.

Design files for this circuit board are available. Call the LTC factory.

LT is registered trademark of Linear Technology

PERFORMANCE SUMMARY Specifications are at TA = 25°C

SYMBOL	PARAMETER	CONDITIONS	MIN	TYP	MAX	UNITS
V _{IN}	Input Supply Range	LT3506A Circuit (TOP)	6.8		25	V
V _{IN}	Input Supply Range	LT3506 Circuit (BOTTOM)	3.6		21	V
V _{OUT1}	Output Voltage Range	LT3506A Circuit (TOP)	4.85	5	5.15	V
V _{OUT2}	Output Voltage Range	LT3506A Circuit (TOP)	3.2	3.3	3.4	V
V _{OUT3}	Output Voltage Range	LT3506 Circuit (BOTTOM)	1.746	1.8	1.854	V
V _{OUT4}	Output Voltage Range	LT3506 Circuit (BOTTOM)	1.164	1.2	1.236	V
I _{OUT}	Output Current	Each Output			1.6	A
F	Switching Frequency	LT3506A Circuit (TOP), I _{OUT} = 1.6A		1100		KHz
F	Switching Frequency	LT3506 Circuit (BOTTOM), I _{OUT} = 1.6A		575		KHz
V _{RIPPLE}	Output Ripple	Each Output, V _{IN} = 12V, I _{OUT} = 1.6A		15		mV
η	Efficiency	LT3506A Circuit (TOP), V _{IN} = 6.8V, I _{OUT1} = 0.9A, I _{OUT2} = 0.9A		86.5		%
η	Efficiency	LT3506 Circuit (BOTTOM), V _{IN} = 3.6V, I _{OUT3} = 0.9A, I _{OUT4} = 0.9A		78		%

LT3506A AND LT3506

QUICK START PROCEDURE

Demonstration circuit 958 is easy to set up to evaluate the performance of the LT3506A and LT3506. Refer to Figure 1 for proper measurement equipment setup and follow the procedure below:

NOTE. When measuring the input or output voltage ripple, care must be taken to avoid a long ground lead on the oscilloscope probe. Measure the input or output voltage ripple by touching the probe tip directly across the VIN or VOUT and GND terminals. See Figure 2 for proper scope probe technique.

1. With power off, connect a 6.8V–25V or a 3.6V–21V input power supply to the VIN and the GND terminals on the board corresponding to the top circuit or the bottom circuit. Each circuit is powered separately from its own VIN and GND.
2. Turn on the power at the input.

NOTE. Make sure that the input voltage does not exceed 25V.

3. Check for the proper output voltages. $V_{OUT1} = 5V$, $V_{OUT2} = 3.3V$, $V_{OUT3} = 1.8V$, $V_{OUT4} = 1.2V$

NOTE. If there is no output, temporarily disconnect the load to make sure that the load is not set too high.

4. The RUN/SS and the Power Good functions are optional and their terminals can be left floating (disconnected) if their functions are not being used. Connecting a RUN/SS terminal to GND will disable the corresponding output.
5. Once the proper output voltages are established, adjust the loads within the operating range and observe the output voltage regulation, ripple voltage, efficiency and other parameters.

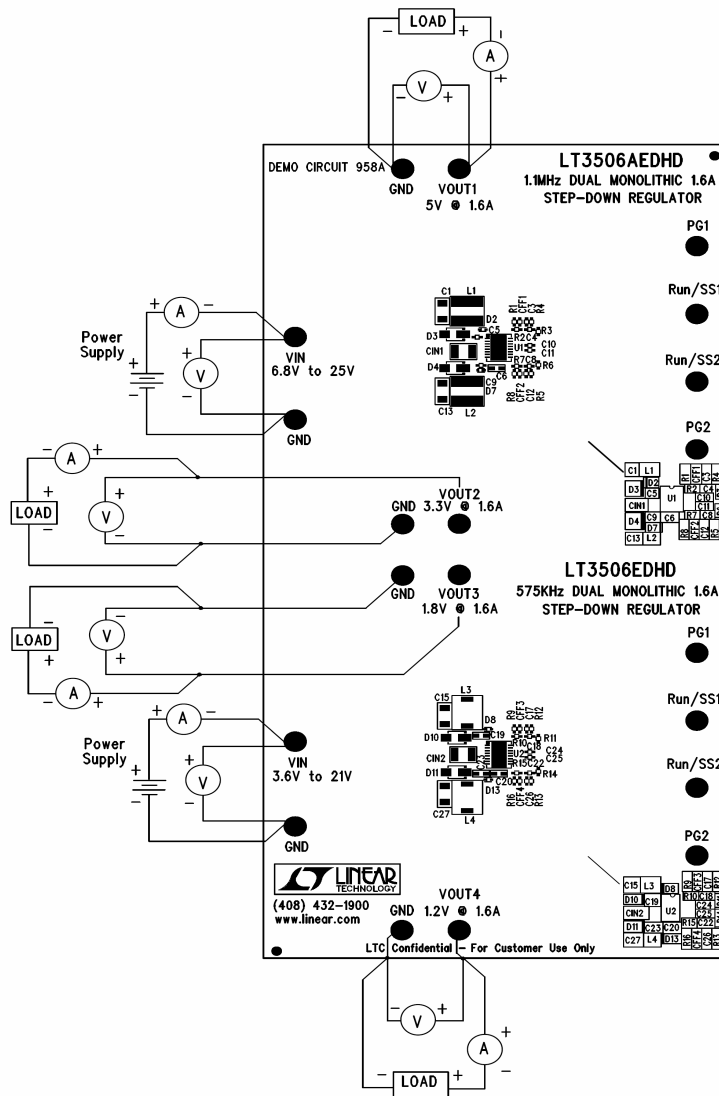

Figure 1. Proper Measurement Equipment Setup

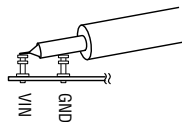
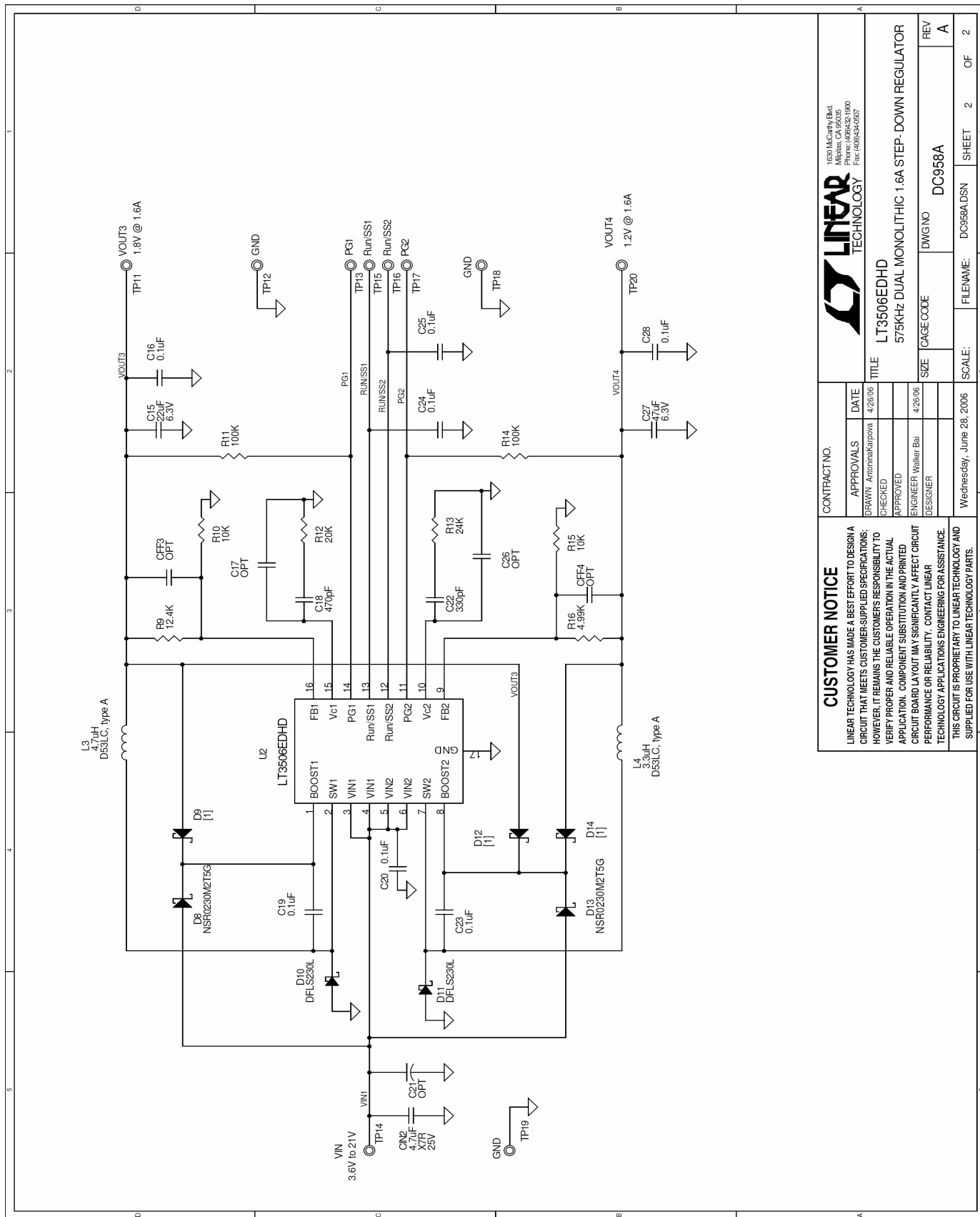

Figure 2. Measuring Input or Output Ripple



CUSTOMER NOTICE

LINEAR TECHNOLOGY HAS MADE A BEST EFFORT TO DESIGN A CIRCUIT THAT MEETS CUSTOMER-SUPPLIED SPECIFICATIONS; HOWEVER, IT REMAINS THE CUSTOMER'S RESPONSIBILITY TO VERIFY PROPER AND RELIABLE OPERATION IN THE ACTUAL APPLICATION. COMPONENT SUBSTITUTION AND PRINTED CIRCUIT BOARD LAYOUT MAY SIGNIFICANTLY AFFECT CIRCUIT PERFORMANCE OR RELIABILITY. CONTACT LINEAR TECHNOLOGY APPLICATIONS ENGINEERING FOR ASSISTANCE. THIS CIRCUIT IS PROPRIETARY TO LINEAR TECHNOLOGY AND SUPPLIED FOR USE WITH LINEAR TECHNOLOGY PARTS.

CONTRACT NO.

APPROVALS	DATE
DRAWN: AntoninaKarpova	4/26/06
CHECKED:	
APPROVED:	
ENGINEER: Walker Bai	4/26/06
DESIGNER:	



1630 McCarthy Blvd.
Milpitas, CA 95035
Phone: (408)432-1900
Fax: (408)432-0607

TITLE	LT3506EDHD
DESCRIPTION	575kHz DUAL MONOLITHIC 1.6A STEP-DOWN REGULATOR
SIZE	CAGE CODE
DWG NO	DC958A
REV	A

SCALE:	1
FILENAME:	DC958A.DSN
SHEET	2
OF	2

Wednesday, June 28, 2006

Компания «Океан Электроники» предлагает заключение долгосрочных отношений при поставках импортных электронных компонентов на взаимовыгодных условиях!

Наши преимущества:

- Поставка оригинальных импортных электронных компонентов напрямую с производств Америки, Европы и Азии, а так же с крупнейших складов мира;
- Широкая линейка поставок активных и пассивных импортных электронных компонентов (более 30 млн. наименований);
- Поставка сложных, дефицитных, либо снятых с производства позиций;
- Оперативные сроки поставки под заказ (от 5 рабочих дней);
- Экспресс доставка в любую точку России;
- Помощь Конструкторского Отдела и консультации квалифицированных инженеров;
- Техническая поддержка проекта, помощь в подборе аналогов, поставка прототипов;
- Поставка электронных компонентов под контролем ВП;
- Система менеджмента качества сертифицирована по Международному стандарту ISO 9001;
- При необходимости вся продукция военного и аэрокосмического назначения проходит испытания и сертификацию в лаборатории (по согласованию с заказчиком);
- Поставка специализированных компонентов военного и аэрокосмического уровня качества (Xilinx, Altera, Analog Devices, Intersil, Interpoint, Microsemi, Actel, Aeroflex, Peregrine, VPT, Syfer, Eurofarad, Texas Instruments, MS Kennedy, Miteq, Cobham, E2V, MA-COM, Hittite, Mini-Circuits, General Dynamics и др.);

Компания «Океан Электроники» является официальным дистрибьютором и эксклюзивным представителем в России одного из крупнейших производителей разъемов военного и аэрокосмического назначения «JONHON», а так же официальным дистрибьютором и эксклюзивным представителем в России производителя высокотехнологичных и надежных решений для передачи СВЧ сигналов «FORSTAR».



JONHON

«JONHON» (основан в 1970 г.)

Разъемы специального, военного и аэрокосмического назначения:

(Применяются в военной, авиационной, аэрокосмической, морской, железнодорожной, горно- и нефтедобывающей отраслях промышленности)

«FORSTAR» (основан в 1998 г.)

ВЧ соединители, коаксиальные кабели, кабельные сборки и микроволновые компоненты:

(Применяются в телекоммуникациях гражданского и специального назначения, в средствах связи, РЛС, а так же военной, авиационной и аэрокосмической отраслях промышленности).



Телефон: 8 (812) 309-75-97 (многоканальный)

Факс: 8 (812) 320-03-32

Электронная почта: ocean@oceanchips.ru

Web: <http://oceanchips.ru/>

Адрес: 198099, г. Санкт-Петербург, ул. Калинина, д. 2, корп. 4, лит. А