



MIC5841/5842

8-Bit Serial-Input Latched Drivers

General Description

Using BiCMOS technology, the MIC5841/5842 integrated circuits were fabricated to be used in a wide variety of peripheral power driver applications. The devices each have an eight-bit CMOS shift register, CMOS control circuitry, eight CMOS data latches, and eight bipolar current-sink Darlington output drivers.

These two devices differ only in maximum voltage ratings. The MIC5842 offers premium performance with a minimum output breakdown voltage rating of 80V (50V sustaining). The drivers can be operated with a split supply where the negative supply is down to -20V.

The 500mA outputs, with integral transient-suppression diodes, are suitable for use with lamps, relays, solenoids and other inductive loads.

These devices have improved speed characteristics. With a 5V logic supply, they will typically operate faster than 5 MHz. With a 12V supply, significantly higher speeds are obtained. The CMOS inputs are compatible with standard CMOS, PMOS, and NMOS logic levels. TTL or DTL circuits may require the use of appropriate pull-up resistors. By using the serial data output, the drivers can be cascaded for interface applications requiring additional drive lines.

The MIC5840 family is available in DIP, PLCC, and SOIC packages. Because of limitations on package power dissipation, the simultaneous operation of all drivers at maximum rated current might require a reduction in duty cycle. A copper-alloy lead frame provides for maximum package power dissipation.

Features

- 3.3 MHz Minimum Data-Input Rate
- CMOS, PMOS, NMOS, TTL Compatible
- Internal Pull-Up/Pull-Down Resistors
- Low-Power CMOS Logic and Latches
- High-Voltage Current-Sink Outputs
- Output Transient-Protection Diodes
- Single or Split Supply Operation

Ordering Information

Part Number		Temperature Range	Package
Standard	Pb-Free		
MIC5841BN	MIC5841YN	-40°C to +85°C	18-Pin Plastic DIP
MIC5841BV	MIC5841YV	-40°C to +85°C	20-Pin PLCC
MIC5841BWM	MIC5841YWM	-40°C to +85°C	18-Pin Wide SOIC
MIC5842BN	MIC5842YN	-40°C to +85°C	18-Pin Plastic DIP
MIC5842BV	MIC5842YV	-40°C to +85°C	20-Pin PLCC
MIC5842BWM	MIC5842YWM	-40°C to +85°C	18-Pin Wide SOIC

Functional Diagram

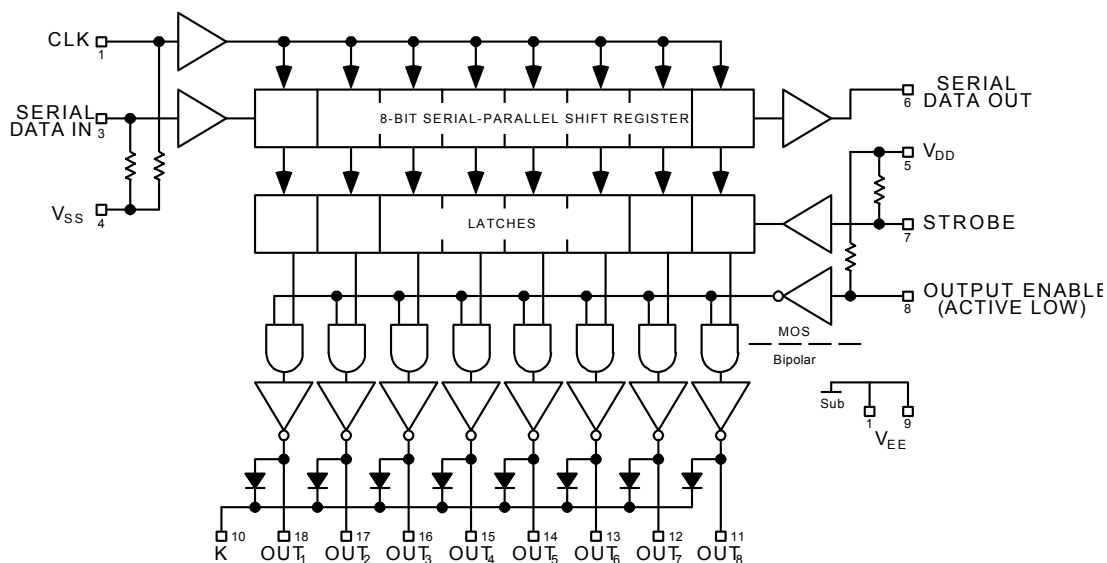

Pin Configuration

(20-Pin PLCC) Top View.

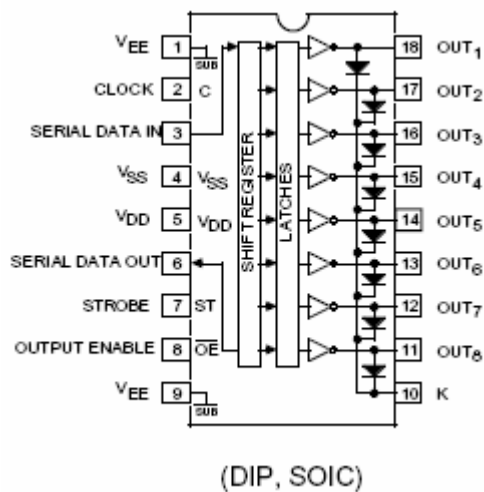
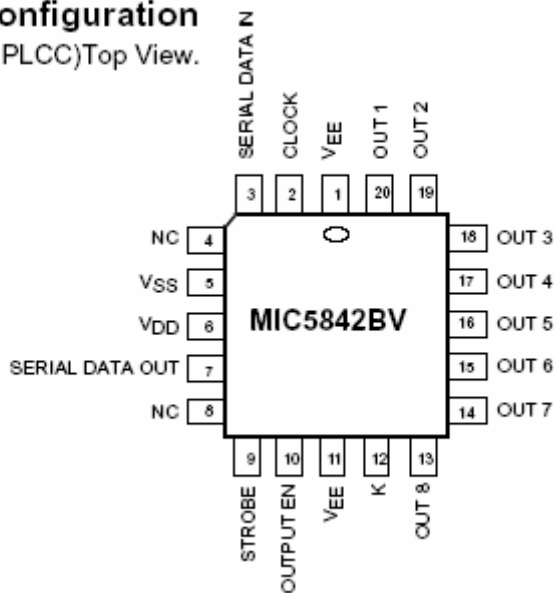

Absolute Maximum Ratings^(1,2,3)

At 25°C Free-Air Temperature and V_{SS}	0V
Output Voltage, V_{CE} (MIC5841)	50V
(MIC5842)	80V
Output Voltage, $V_{CE(SUS)}$ (MIC5841) ⁽¹⁾	35V
(MIC5842)	50V
Logic Supply Voltage, V_{DD}	15V
VDD with Reference to V_{EE}	25V

Emitter Supply Voltage, V_{EE}	-20V
Input Voltage Range, V_{IN}	-0.3V to $V_{DD} + 0.3V$
Continuous Output Current, I_{OUT}	500mA
Package Power Dissipation, P_D ⁽²⁾	1.82W
Operating Temperature Range, T_A	-55°C to +85°C
Storage Temperature Range, T_S	-65°C to +150°C

Electrical CharacteristicsAt $T_A = 25^\circ\text{C}$ $V_{DD} = 5V$, $V_{SS} = V_{EE} = 0V$ (unless otherwise noted)

Characteristic	Symbol	Applicable Devices	Test Conditions	Limits		
				Min	Max	Unit
Output Leakage Current	I_{CEX}	MIC5841	$V_{OUT} = 50V$		50	μA
			$V_{OUT} = 50V, T_A = +70^\circ\text{C}$		100	
		MIC5842	$V_{OUT} = 80V$		50	
			$V_{OUT} = 80V, T_A = +70^\circ\text{C}$		100	
Collector-Emitter Saturation Voltage	$V_{CE(SAT)}$	Both	$I_{OUT} = 100\text{mA}$		1.1	V
			$I_{OUT} = 200\text{mA}$		1.3	
			$I_{OUT} = 350\text{mA}, V_{DD} = 7.0V$		1.6	
Collector-Emitter Saturation Voltage	$V_{CE(SUS)}^{(5)}$	MIC5841	$I_{OUT} = 350\text{mA}, L = 2\text{mH}$	35		V
		MIC5842	$I_{OUT} = 350\text{mA}, L = 2\text{mH}$	50		
Input Voltage	$V_{IN(0)}$	Both			0.8	V
	$V_{IN(1)}$	Both	$V_{DD} = 12V$	10.5		
			$V_{DD} = 10V$	8.5		
Input Resistance	R_{IN}	Both	$V_{DD} = 12V$	50		$k\Omega$
			$V_{DD} = 10V$	50		
			$V_{DD} = 5.0V$	50		
Supply Current	$I_{DD(ON)}$	Both	All Drivers ON, $V_{DD} = 12V$		16	1.6
			All Drivers ON, $V_{DD} = 10V$		14	
			All Drivers ON, $V_{DD} = 5.0V$		8.0	
	$I_{DD(OFF)}$	Both	All Drivers OFF, $V_{DD} = 12V$		2.9	
			All Drivers OFF, $V_{DD} = 10V$		2.5	
			All Drivers OFF, $V_{DD} = 5.0V$		1.6	
Clamp Diode Leakage Current	I_R	MIC5841	$V_R = 50V$		50	μA
		MIC5842	$V_R = 80V$		50	
Clamp Diode Forward Voltage	V_F	Both	$I_F = 350\text{mA}$		2.0	V

Electrical Characteristics

At $T_A = -55^\circ\text{C}$ $V_{DD} = 5\text{V}$, $V_{SS} = V_{EE} = 0\text{V}$ (unless otherwise noted)

Characteristic	Symbol	Test Conditions	Limits		
			Min	Max	Unit
Output Leakage Current	I_{CEX}	$V_{OUT} = 80\text{V}$		50	μA
Collector-Emitter Saturation Voltage	$V_{CE(SAT)}$	$I_{OUT} = 100\text{mA}$		1.3	V
		$I_{OUT} = 200\text{mA}$		1.5	
		$I_{OUT} = 350\text{mA}$, $V_{DD} = 7.0\text{V}$		1.8	
Input Voltage	$V_{IN(0)}$			0.8	V
	$V_{IN(1)}$	$V_{DD} = 12\text{V}$	10.5		
		$V_{DD} = 5.0\text{V}$	3.5		
Input Resistance	R_{IN}	$V_{DD} = 12\text{V}$	35		$\text{k}\Omega$
		$V_{DD} = 10\text{V}$	35		
		$V_{DD} = 5.0\text{V}$	35		
Supply Current	$I_{DD(ON)}$	All Drivers ON, $V_{DD} = 12\text{V}$		16	mA
		All Drivers ON, $V_{DD} = 10\text{V}$		14	
		All Drivers ON, $V_{DD} = 5.0\text{V}$		10	
	$I_{DD(OFF)}$	All Drivers OFF, $V_{DD} = 12\text{V}$		3.5	
		All Drivers OFF, $V_{DD} = 5.0\text{V}$		2.0	

Electrical Characteristics

At $T_A = +125^\circ\text{C}$ $V_{DD} = 5\text{V}$, $V_{SS} = V_{EE} = 0\text{V}$ (unless otherwise noted)

Characteristic	Symbol	Test Conditions	Limits		
			Min	Max	Unit
Output Leakage Current	I_{CEX}	$V_{OUT} = 80\text{V}$		500	μA
Collector-Emitter Saturation Voltage	$V_{CE(SAT)}$	$I_{OUT} = 100\text{mA}$		1.3	V
		$I_{OUT} = 200\text{mA}$		1.5	
		$I_{OUT} = 350\text{mA}$, $V_{DD} = 7.0\text{V}$		1.8	
Input Voltage	$V_{IN(0)}$			0.8	V
	$V_{IN(1)}$	$V_{DD} = 12\text{V}$	10.5		
		$V_{DD} = 5.0\text{V}$	3.5		
Input Resistance	R_{IN}	$V_{DD} = 12\text{V}$	50		$\text{k}\Omega$
		$V_{DD} = 10\text{V}$	50		
		$V_{DD} = 5.0\text{V}$	50		
Supply Current	$I_{DD(ON)}$	All Drivers ON, $V_{DD} = 12\text{V}$		16	mA
		All Drivers ON, $V_{DD} = 10\text{V}$		14	
		All Drivers ON, $V_{DD} = 5.0\text{V}$		8	
	$I_{DD(OFF)}$	All Drivers OFF, $V_{DD} = 12\text{V}$		2.9	
		All Drivers OFF, $V_{DD} = 5.0\text{V}$		2.1.6	
Clamp Diode Leakage Current	I_R	MIC5841A $V_R = 50\text{V}$		1.6	μA
		MIC5842A $V_R = 80\text{V}$		100	

Notes:

1. For Inductive load applications.
2. Derate at the rate of $18.2\text{mW}/^\circ\text{C}$ above $T_A = 25^\circ\text{C}$ (Plastic DIP)
3. CMOS devices have input-static protection but are susceptible to damage when exposed to extremely high static electrical charges.
4. Operation of these devices with standard TTL may require the use of appropriate pull-up resistors to insure an input logic HIGH.
5. Not 100% tested. Guaranteed by design.

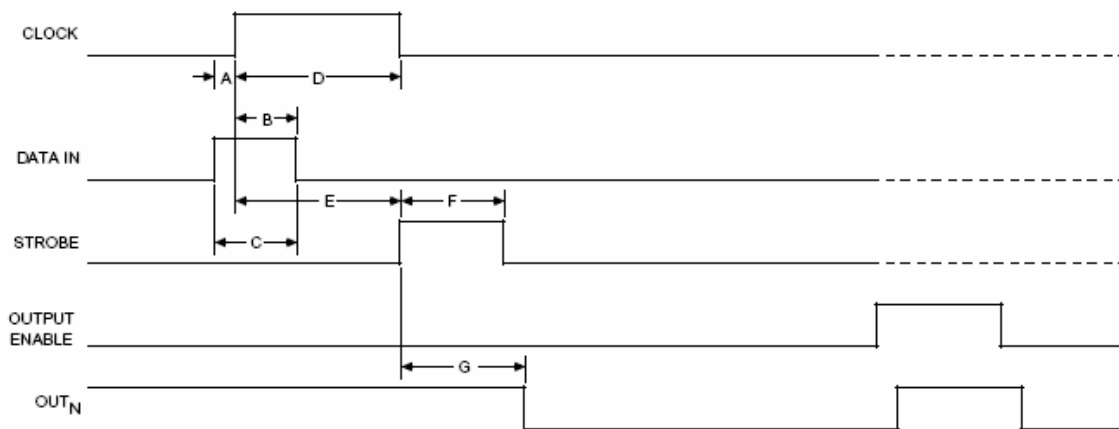

Timing Conditions

(TA = 25°C Logic Levels are V_{DD} and V_{SS})

V_{DD} = 5V

- A. Minimum Data Active Time Before Clock Pulse (Data Set-Up Time)..... 75 ns
- B. Minimum Data Active Time After Clock Pulse (Data Hold Time) 75 ns
- C. Minimum Data Pulse Width 150 ns
- D. Minimum Clock Pulse Width..... 150 ns
- E. Minimum Time Between Clock Activation and Strobe 300 ns
- F. Minimum Strobe Pulse Width..... 100 ns
- G. Typical Time Between Strobe Activation and Output Transition..... 500 ns

SERIAL DATA present at the input is transferred to the shift register on the logic “0” to logic “1” transition of the CLOCK input pulse. On succeeding CLOCK pulses, the registers shift data information towards the SERIAL DATA OUTPUT. The SERIAL DATA must appear at the input prior to the rising edge of the CLOCK input waveform.

Information present at any register is transferred to its respective latch when the STROBE is high (serial-to-parallel conversion). The latches will continue to accept new data as long as the STROBE is held high. Applications where the latches are bypassed (STROBE tied high) will require that the ENABLE input be high during serial data entry.

When the ENABLE input is high, all of the output buffers are disabled (OFF) without affecting information stored in the latches or shift register. With the ENABLE input low, the outputs are controlled by the state of the latches.

MIC5840 Family Truth Table

Serial Data Input	Clock Input	Shift Register Contents					Serial Data Output	Strobe Input	Latch Contents					Output Enable	Output Contents					
		I ₁	I ₂	I ₃	...	I ₈			I ₁	I ₂	I ₃	...	I ₈		I ₁	I ₂	I ₃	...	I ₈	
H		H	R1	R2	...	R7	R7													
L		L	R1	R2	...	R7	R7													
X		R1	R2	R3	...	R8	R8													
		X	X	X	...	X	X	L	R1	R2	R3	...	R8							
		P1	P2	P3	...	P8	P8	H	P1	P2	P3	...	P8	L	P1	P2	P3	...	P8	
									X	X	X	...	X	H	H	H	H	...	H	

L = Low Logic Level
H = High Logic Level
X = Irrelevant
P = Present State
R = Previous State

Typical Output Driver

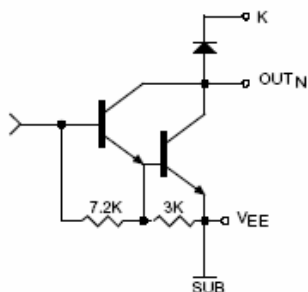

Typical Input Circuits



Maximum Allowable Duty Cycle (Plastic DIP)

$V_{DD} = 5.0V$

Number of Outputs ON ($I_{OUT} = 200mA$ $V_{DD} = 5.0V$)	Max. Allowable Duty Cycle at Ambient Temperature of				
	25°C	40°C	50°C	60°C	70°C
8	85%	72%	64%	55%	46%
7	97%	82%	73%	63%	53%
6	100%	96%	85%	73%	62%
5	100%	100%	100%	88%	75%
4	100%	100%	100%	100%	93%
3	100%	100%	100%	100%	100%
2	100%	100%	100%	100%	100%
1	100%	100%	100%	100%	100%

$V_{DD} = 12V$

Number of Outputs ON ($I_{OUT} = 200mA$ $V_{DD} = 12V$)	Max. Allowable Duty Cycle at Ambient Temperature of				
	25°C	40°C	50°C	60°C	70°C
8	80%	68%	60%	52%	44%
7	91%	77%	68%	59%	50%
6	100%	90%	79%	69%	58%
5	100%	100%	95%	82%	69%
4	100%	100%	100%	100%	86%
3	100%	100%	100%	100%	100%
2	100%	100%	100%	100%	100%
1	100%	100%	100%	100%	100%

Typical Applications

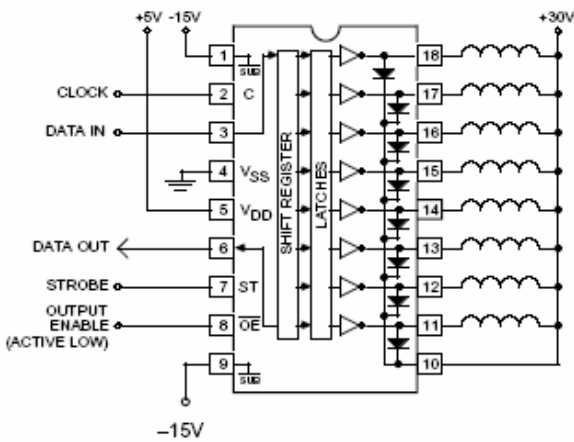

Relay/Solenoid Driver MIC5842

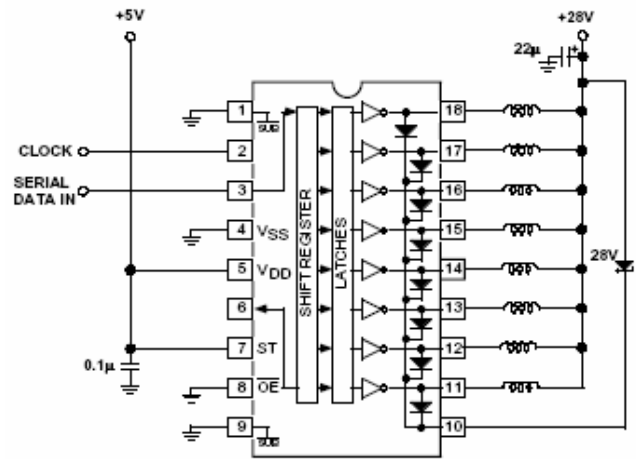

MIC5841 Hammer Driver



MIC5841 Solenoid Driver with Output Enable

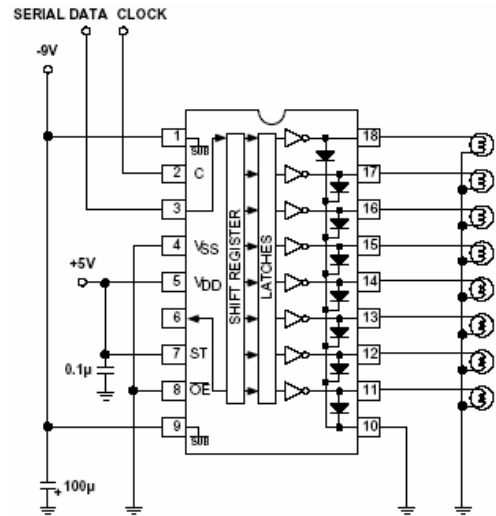

MIC5841 Level Shifting Lamp Driver with Darlington Emitters Tied to a Negative Supply

Typical Applications, Continued



MICREL, INC. 2180 FORTUNE DRIVE SAN JOSE, CA 95131 USA
 TEL +1 (408) 944-0800 FAX +1 (408) 474-1000 WEB <http://www.micrel.com>

The information furnished by Micrel in this data sheet is believed to be accurate and reliable. However, no responsibility is assumed by Micrel for its use. Micrel reserves the right to change circuitry and specifications at any time without notification to the customer.

Micrel Products are not designed or authorized for use as components in life support appliances, devices or systems where malfunction of a product can reasonably be expected to result in personal injury. Life support devices or systems are devices or systems that (a) are intended for surgical implant into the body or (b) support or sustain life, and whose failure to perform can be reasonably expected to result in a significant injury to the user. A Purchaser's use or sale of Micrel Products for use in life support appliances, devices or systems is a Purchaser's own risk and Purchaser agrees to fully indemnify Micrel for any damages resulting from such use or sale.

© 1998 Micrel, Incorporated.

Компания «Океан Электроники» предлагает заключение долгосрочных отношений при поставках импортных электронных компонентов на взаимовыгодных условиях!

Наши преимущества:

- Поставка оригинальных импортных электронных компонентов напрямую с производств Америки, Европы и Азии, а так же с крупнейших складов мира;
- Широкая линейка поставок активных и пассивных импортных электронных компонентов (более 30 млн. наименований);
- Поставка сложных, дефицитных, либо снятых с производства позиций;
- Оперативные сроки поставки под заказ (от 5 рабочих дней);
- Экспресс доставка в любую точку России;
- Помощь Конструкторского Отдела и консультации квалифицированных инженеров;
- Техническая поддержка проекта, помощь в подборе аналогов, поставка прототипов;
- Поставка электронных компонентов под контролем ВП;
- Система менеджмента качества сертифицирована по Международному стандарту ISO 9001;
- При необходимости вся продукция военного и аэрокосмического назначения проходит испытания и сертификацию в лаборатории (по согласованию с заказчиком);
- Поставка специализированных компонентов военного и аэрокосмического уровня качества (Xilinx, Altera, Analog Devices, Intersil, Interpoint, Microsemi, Actel, Aeroflex, Peregrine, VPT, Syfer, Eurofarad, Texas Instruments, MS Kennedy, Miteq, Cobham, E2V, MA-COM, Hittite, Mini-Circuits, General Dynamics и др.);

Компания «Океан Электроники» является официальным дистрибьютором и эксклюзивным представителем в России одного из крупнейших производителей разъемов военного и аэрокосмического назначения «JONHON», а так же официальным дистрибьютором и эксклюзивным представителем в России производителя высокотехнологичных и надежных решений для передачи СВЧ сигналов «FORSTAR».



JONHON

«JONHON» (основан в 1970 г.)

Разъемы специального, военного и аэрокосмического назначения:

(Применяются в военной, авиационной, аэрокосмической, морской, железнодорожной, горно- и нефтедобывающей отраслях промышленности)

«FORSTAR» (основан в 1998 г.)

ВЧ соединители, коаксиальные кабели, кабельные сборки и микроволновые компоненты:

(Применяются в телекоммуникациях гражданского и специального назначения, в средствах связи, РЛС, а так же военной, авиационной и аэрокосмической отраслях промышленности).



Телефон: 8 (812) 309-75-97 (многоканальный)

Факс: 8 (812) 320-03-32

Электронная почта: ocean@oceanchips.ru

Web: <http://oceanchips.ru/>

Адрес: 198099, г. Санкт-Петербург, ул. Калинина, д. 2, корп. 4, лит. А