

Power Supply ICs for TFT-LCD Panels

5V Input Multi-channel System Power Supply ICs



BD8163EFV

No.10035EAT13

●Description

The BD8163EFV is a system power supply IC for TFT panels. A 1-chip IC providing a total of four voltages required for TFT panels, i.e., logic voltage, sauce voltage, gate high-level, and gate low-level voltage, thus constructing a TFT panel power supply with minimal components required.

●Features

- 1) Operates in an operating voltage range as low as 2.1 V to 6.0 V.
- 2) Incorporates a step-up DC/DC converter.
- 3) Incorporates a 2.5 V regulator.
- 4) Incorporates positive and negative-side charge pumps.
- 5) Switching frequency of 1100 kHz
- 6) DC/DC converter feedback voltage of $1.24\text{ V} \pm 1\%$
- 7) Incorporates a gate shading function
- 8) Under-voltage lockout protection circuit
- 9) Thermal shutdown circuit
- 10) Overcurrent protection circuit
- 11) HTSSOP-B24 package

●Applications

Liquid crystal TV, PC monitor, and TFT-LCD panel

●Absolute maximum ratings (Ta = 25°C)

Parameter	Symbol	Ratings	Unit
Power supply voltage	VCC	7	V
Vo1 voltage	Vo1	19	V
Vo2 voltage	Vo2	32	V
SW voltage	Vsw	19	V
Maximum junction temperature	Tjmax	150	°C
Power dissipation	Pd	1100*	mW
Operating temperature range	Topr	-40 to 125	°C
Storage temperature range	Tstg	-55 to 150	°C

* Reduced by 4.7 mW/°C over 25°C, when mounted on a glass epoxy board. (70 mm × 70 mm × 1.6 mm).

●Recommended Operating Ranges

Parameter	Symbol	Ratings		Unit
		Min.	Max.	
Power supply voltage	VCC	2.1	6	V
Vo1 voltage	Vo1	8	18	V
Vo2 voltage	Vsw	—	18	V
SW Current	Isw	—	1.8	A
Vo2 Current	Vo2	—	30	V

● Electrical Characteristics (Unless otherwise specified, VCC = 5 V; Vo1 = 15 V; Vo2 = 25 V; Ta = 25°C)

1 DC/DC Converter Block

Parameter	Symbol	Limits			Unit	Conditions
		Min.	Typ.	Max.		
[Soft start]						
Source current	I _{so}	6	10	14	μA	V _{ss} = 0.5 V
Sinking current	I _{si}	0.1	0.2	1.0	mA	V _{ss} = 0.5 V, VDD = 1.65 V
[Error amp]						
Input bias current 1	I _{FB1}	—	0.1	0.5	μA	
Feedback voltage 1	V _{FB1}	1.227	1.240	1.253	V	Buffer
Voltage gain	A _V	—	200	—	V/V	*
Sinking current	I _{ol}	25	50	100	μA	V _{FB} = 1.5 V V _{COMP} = 0.5 V
Source current	I _{oo}	-100	-50	-25	μA	V _{FB} = 1.0 V V _{COMP} = 0.5 V
[SW]						
ON resistance N-channel	R _{ON_N}	50	200	600	mΩ	*
Leak current N-channel	I _{LEAKN}	—	—	10	μA	V _{sw} = 18 V
Maximum duty cycle	D _{MAX}	75	85	95	%	
[Overcurrent protection]						
Saw current limit	I _{sw}	2	3	—	A	*

2. Regulator controller

Parameter	Symbol	Limits			Unit	Conditions
		Min.	Typ.	Max.		
[Error amp]						
VDD voltage	VDD	2.4	2.5	2.6	V	
Maximum base current	I _{BMAX}	2	7	15	mA	
Line regulation	Reg _L	—	10	30	mV	V _{cc} = 4.5 V to 5.5 V
Load regulation	Reg _L	—	10	50	mV	I _o = 10 mA to 100 mA
[Under-voltage lockout protection]						
Off threshold voltage	V _{ROFF}	1.7	1.8	1.9	V	
On threshold voltage	V _{RON}	1.6	1.7	1.8	V	

○ This product is not designed for protection against radioactive rays.

* Design guarantee (No total shipment inspection is made.)

3. Charge pump

Parameter	Symbol	Limits			Unit	Conditions
		Min.	Typ.	Max.		
[Error amp]						
Input bias current 2	I_{FB2}	—	0.1	0.5	μA	
Input bias current 3	I_{FB3}	—	0.1	0.5	μA	
Feedback voltage 2	V_{FB2}	1.183	1.240	1.307	V	
Feedback voltage 3	V_{FB3}	0.15	0.2	0.25	V	
[Delay start block]						
Source current	I_{DSO}	3	5	7	μA	VDLS = 0.5V
Sinking current	I_{DSI}	0.1	0.5	1.0	mA	VDLS = 0.5V
Startup voltage	V_{ST}	0.45	0.60	0.75	V	
[Switch]						
ON resistance N-channel	R_{ON_NC}	0.5	2	4	Ω	$I_o = 10 \text{ mA}^*$
ON resistance P-channel	R_{ON_PC}	0.5	4	8	Ω	$I_o = -10 \text{ mA}^*$
[Diode]						
Voltage of diode	V_f	600	710	800	mV	$I_o = 10 \text{ mA}$
[Gate shading block]						
ON resistance N-channel	R_{ON_NGS}	2	10	20	Ω	$I_o = 10 \text{ mA}^*$
ON resistance P-channel	R_{ON_PGS}	2	10	20	Ω	$I_o = -10 \text{ mA}^*$
Leak current N-channel	I_{LEAK_NGS}	—	—	10	μA	
Leak current P-channel	I_{LEAK_PGS}	—	—	10	μA	
High voltage	IGH	$V_{DD} \times 0.7$	VDD	—	V	
Low voltage	IGL	—	0	$V_{DD} \times 0.3$	V	
Input current	IIG	8	16.5	30	μA	$I_G = 3.3 \text{ V}$

○ This product is not designed for protection against radioactive rays.

* Design guarantee (No total shipment inspection is made.)

4. Overall

Parameter	Symbol	Limits			Unit	Conditions
		Min.	Typ.	Max.		
[Reference block]						
Reference voltage	V_{REF}	1.215	1.240	1.265	V	
Drive current	I_{REF}	—	23	—	mA	$V_{REF} = 0\text{ V}$
Load regulation	ΔV	—	1	10	mV	$I_{REF} = -1\text{ mA}$
[Oscillator]						
Oscillating frequency	F_{osc}	0.94	1.1	1.265	MHz	
[Oscillator]						
DET 1 On threshold voltage	V_{DON1}	1.7	1.8	1.9	V	
DET 1 Off threshold voltage	V_{DOFF1}	1.6	1.7	1.8	V	
DET 2 On threshold voltage	V_{DON2}	1.02	1.12	1.22	V	
DET 2 Off threshold voltage	V_{DOFF2}	0.90	1.00	1.10	V	
DET 3 On threshold voltage	V_{DON3}	0.25	0.30	0.35	V	
DET 3 Off threshold voltage	V_{DOFF3}	0.35	0.41	0.47	V	
DET 4 On threshold voltage	V_{DON4}	1.02	1.12	1.22	V	
DET 4 Off threshold voltage	V_{DOFF4}	0.90	1.00	1.10	V	
[Device]						
Average circuit current	I_{CC}	0.5	2	5	mA	No switching

○ This product is not designed for protection against radioactive rays.

●Reference Data (Unless otherwise specified, Ta = 25°C)

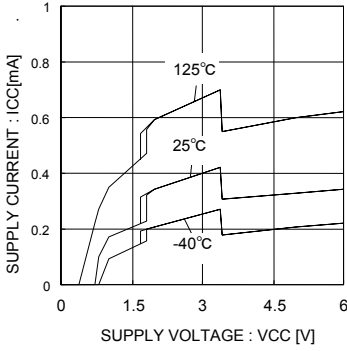

Fig. 1 Total Supply Current 1

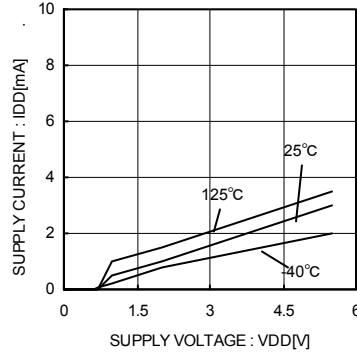

Fig. 2 Total Supply Current 2

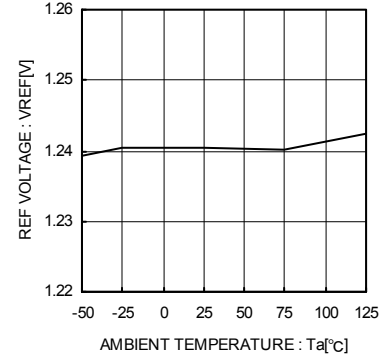

Fig. 3 Internal Reference Temperature

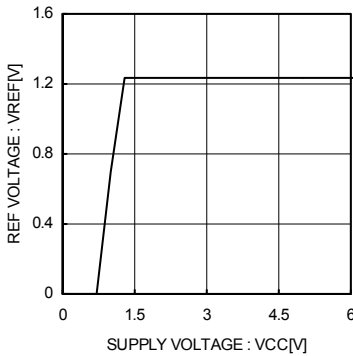

Fig. 4 Internal Reference Line Regulation

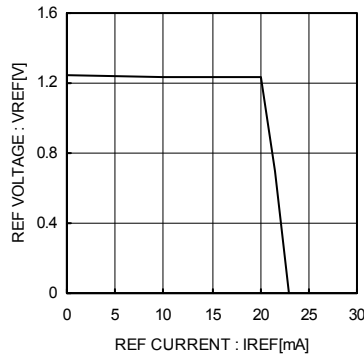

Fig. 5 Internal Reference Load Regulation

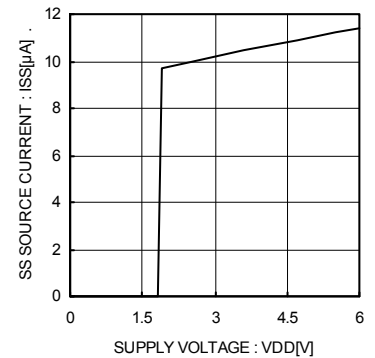

Fig. 6 SS Source Current

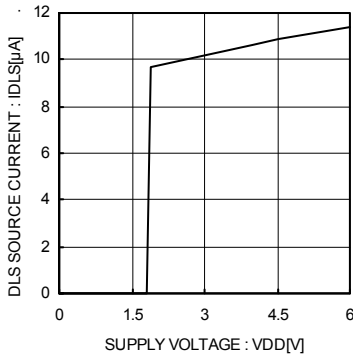

Fig. 7 DLS Source Current

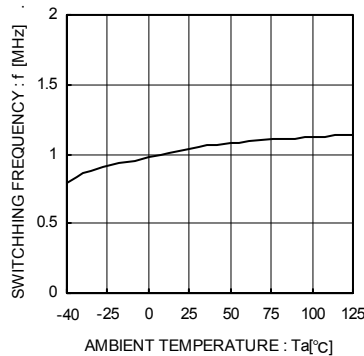

Fig. 8 Switching Frequency Temperature

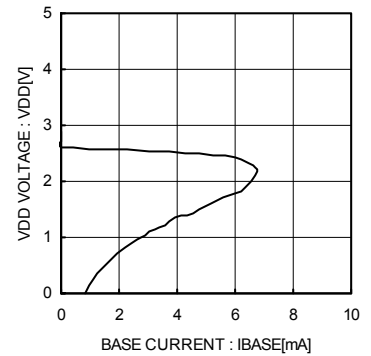

Fig. 9 REG Current Capacity

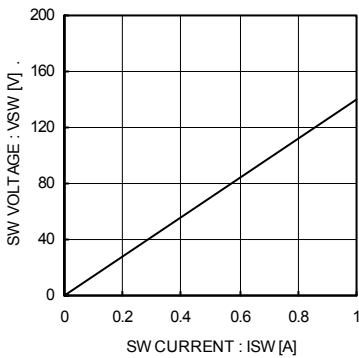

Fig. 10 SW On Resistance

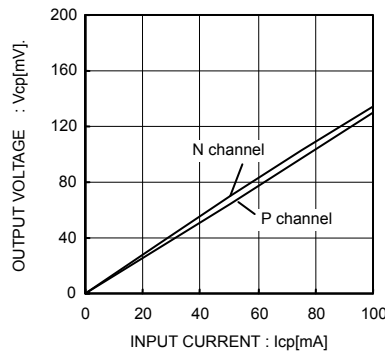

Fig. 11 Charge Pump On Voltage

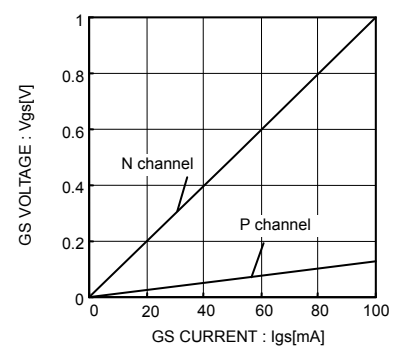

Fig. 12 Gate Shading On Voltage

●Reference Data (Unless otherwise specified, Ta = 25°C)

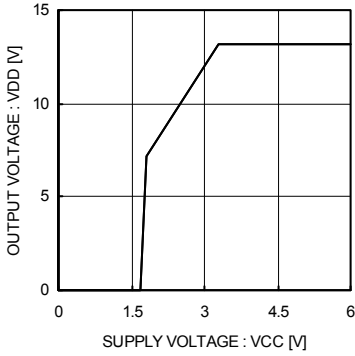

Fig. 13 Vo1 Line Regulation

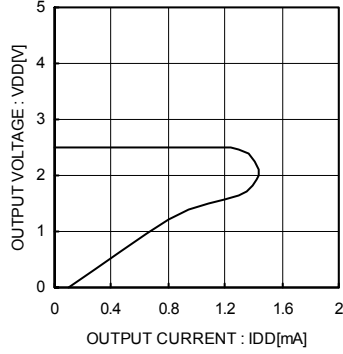

Fig. 14 VDD Load Regulation

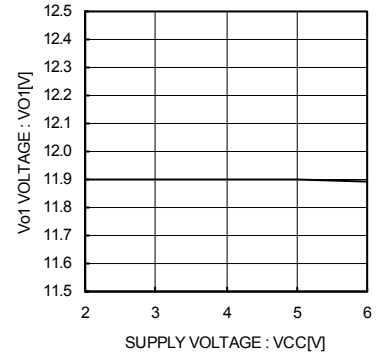

Fig. 15 Vo1 Line Regulation

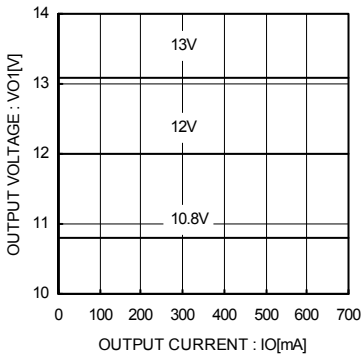

Fig. 16 Vo1 Load Regulation

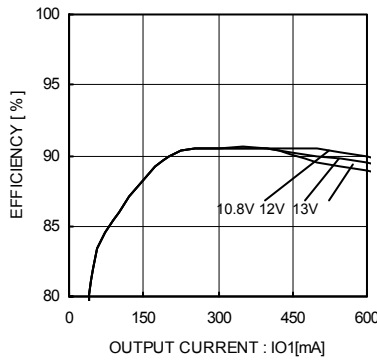

Fig. 17 Efficiency vs Output Current

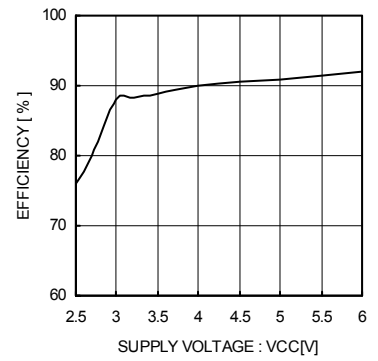

Fig. 18 Efficiency vs Power Supply Voltage

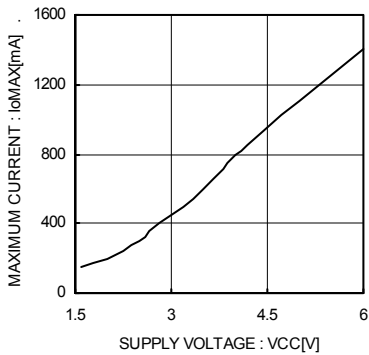

Fig. 19 Power Supply Voltage vs Max. Output Current Capacity

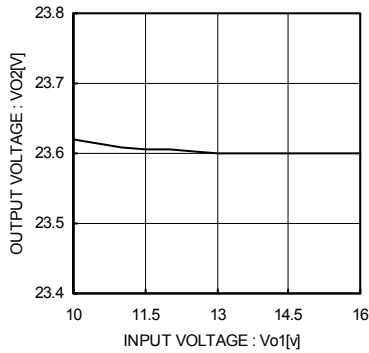

Fig. 20 Vo2 Line Regulation

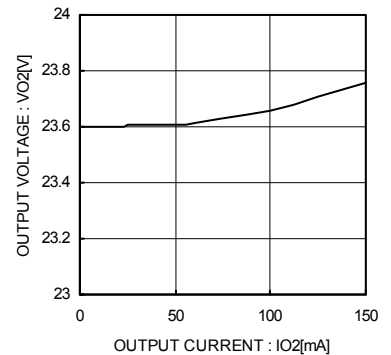

Fig. 21 Vo2 Load Regulation

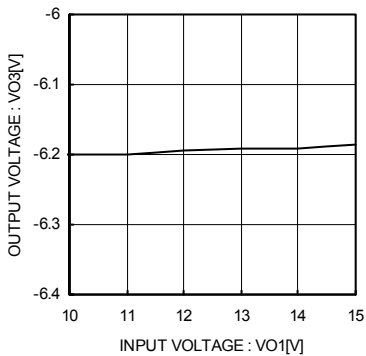

Fig. 22 Negative-side Charge Pump Line Regulation

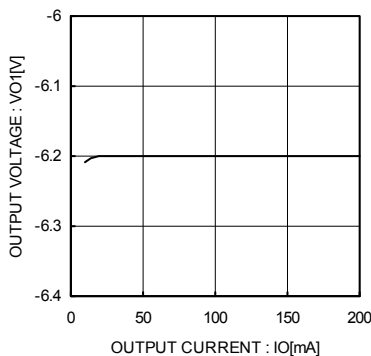

Fig. 23 Negative-side Charge Pump Load Regulation

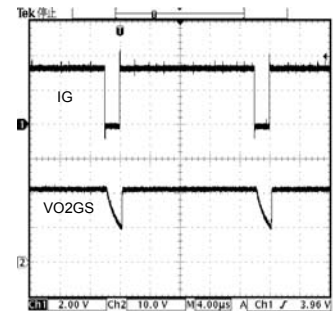

Fig. 24 Gate Shading Output Waveform

●Block Diagram

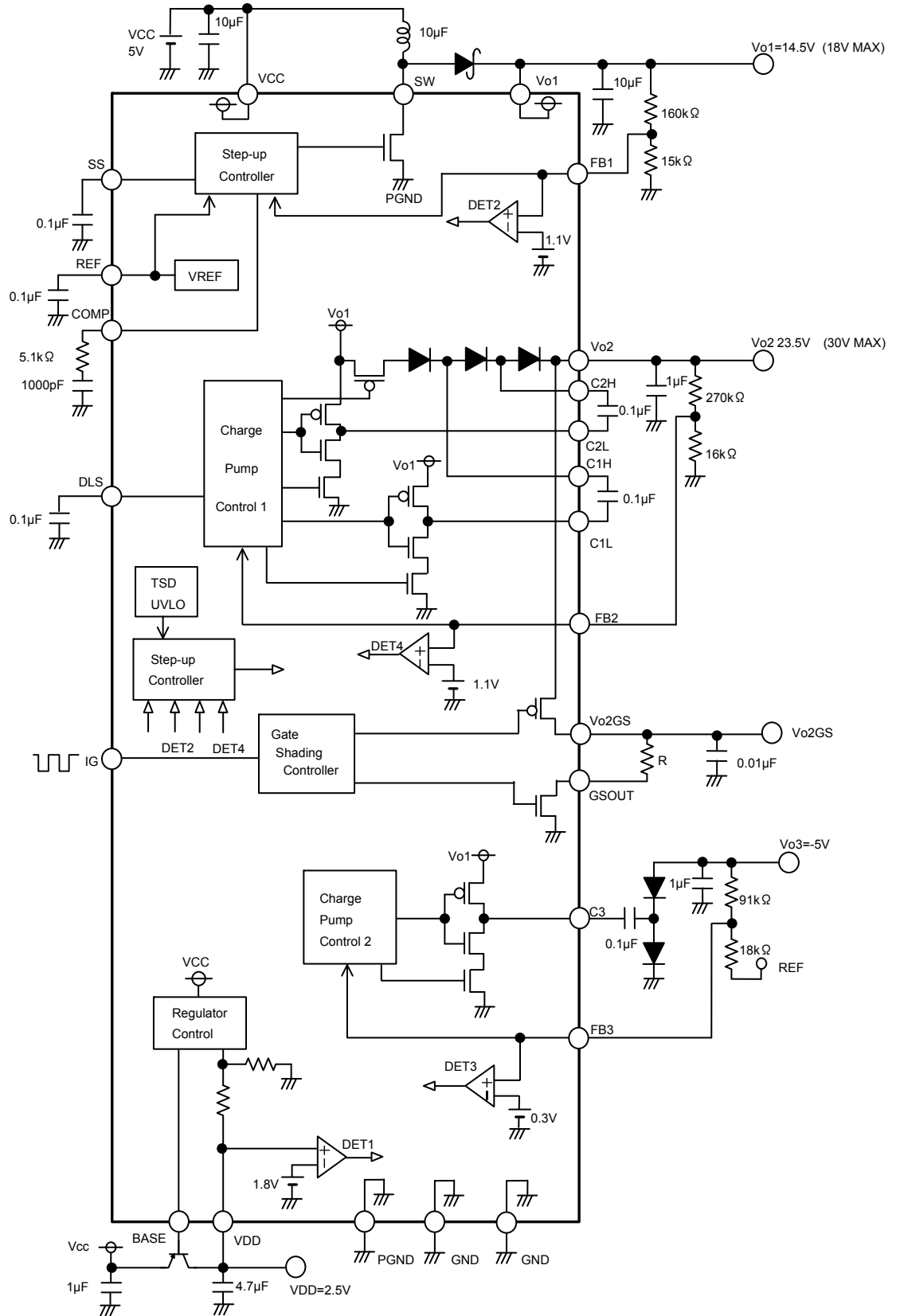
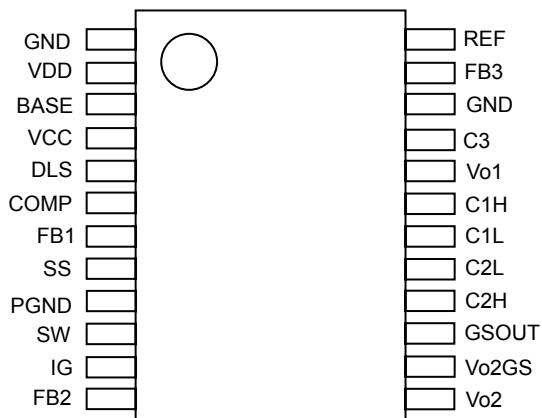

Fig. 25 Block Diagram

●Pin Assignments Diagram



Pin Arrangements

●Pin Assignments and Function

PIN NO.	Pin name	Function	PIN NO.	Pin name	Function
1	GND	Ground pin	13	Vo2	Positive-side charge pump output
2	VDD	LDO feedback input pin	14	Vo2GS	Gate shading source output pin
3	BASE	LDO base drive output pin	15	GSOUT	Gate shading sink output pin
4	VCC	Power supply input pin	16	C2H	Flying capacitor connection pin
5	DLS	Capacity connection pin for delay start	17	C2L	Flying capacitor connection pin
6	COMP	DC/DC difference amplifier output	18	C1L	Flying capacitor connection pin
7	FB1	DC/DC feedback input	19	C1H	Flying capacitor connection pin
8	SS	Soft start capacitor connection pin	20	Vo1	Negative-side charge pump power supply input pin
9	PGND	Ground pin	21	C3	Negative-side charge pump driver output
10	SW	Switch output	22	GND	Ground pin
11	IG	Gate shading input	23	FB3	Negative-side charge pump feedback input
12	FB2	Positive-side charge pump feedback input	24	REF	Internal standard output pin

●Block Function

- Step-up Controller
A controller circuit for DC/DC boosting.
The switching duty is controlled so that the feedback voltage FB1 is set to 1.24 V (typ.). A soft start operates at the time of starting. Therefore, the switching duty is controlled by the SS pin voltage.
- Charge Pump Control 1
A controller circuit for the positive-side charge pump.
The switching amplitude is controlled so that the feedback voltage FB2 will be set to 1.24 V (typ.). The start delay time can be set in the DLS terminal at the time of starting. When the DLS voltage reaches 0.6 V (Typ.), switching waves will be output from the C1L and C2L pins.
- Charge Pump Control 2
A controller circuit for the negative-side charge pump.
The switching amplitude is controlled so that the feedback voltage FB2 will be set to 0.6 V (Typ.).
- Gate Shading Controller
A controller circuit of gate shading.
The Vo2GS and GSOUT are in on/off control according to IG pin input.
- Regulator Control
A regulator controller circuit for VDD voltage generation.
The base pin current is controlled so that V_{DD} voltage will be set to 2.5 V (typ.).
- DET 1 to DET 4
A detection circuit of each output voltage. This detected signal is used for the starting sequential circuit.
- Start-up Controller
A control circuit for the starting sequence.
Controls to start in order of V_{CC} → VDD → Vo1 → Vo3 → Vo2.
- VREF
A block that generates internal reference voltage. 1.24V (Typ.) is output.
- TSD/UVLO
Thermal shutdown/Under-voltage lockout protection/circuit blocks.
The thermal shutdown circuit is shut down at an IC internal temperature of 175°C and reset at 160°C. The under-voltage lockout protection circuit shuts down the IC when the V_{CC} is 1.8 V (typ.) or below.
- Starting sequence
For malfunction prevention, starting logic control operates so that each output will rise in order of V_{CC} → VDD → Vo1 → Vo3 → Vo2.
As shown below, detectors DET1 to DET3 detect that the output on the detection side has reached 90% (typ.) of the set voltage, and starts the next block.

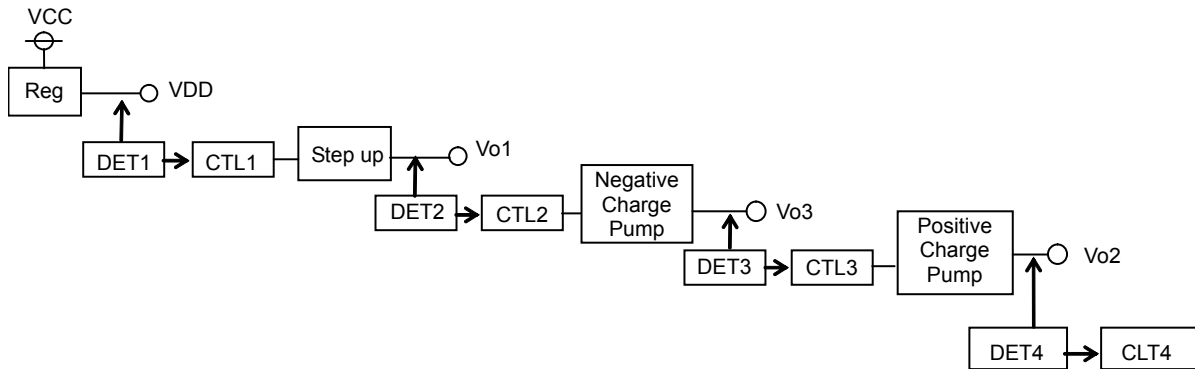

Starting sequence model

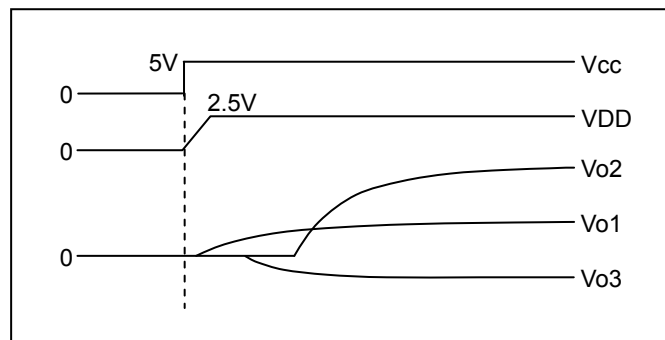

Fig. 26 Starting Timing Chart

●Selecting Application Components

(1) Setting the Output L Constant

The coil to use for output is decided by the rating current I_{LR} and input current maximum value I_{INMAX} of the coil.

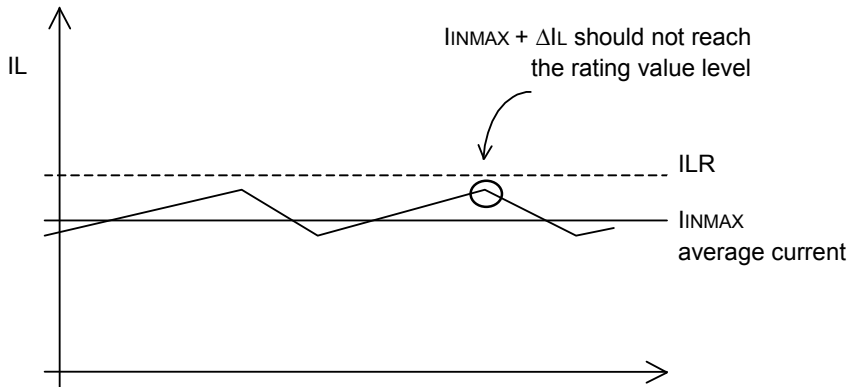

Fig. 27 Coil Current Waveform

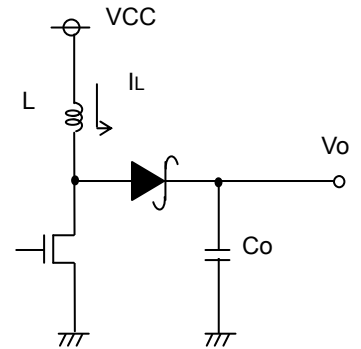

Fig. 28 Output Application Circuit Diagram

Adjust so that $I_{INMAX} + \Delta I_L$ do not reach the rating current value I_{LR} . At this time, ΔI_L can be obtained by the following equation.

$$\Delta I_L = \frac{1}{L} V_{CC} \times \frac{V_o - V_{CC}}{V_{CC}} \times \frac{1}{f} \text{ [A]} \quad \text{Here, } f \text{ is the switching frequency.}$$

Set with sufficient margin because the coil value may have the dispersion of $\pm 30\%$. If the coil current exceeds the rating current I_{LR} of the coil, it may damage the IC internal element.

BD8163EFV uses the current mode DC/DC converter control and has the optimized design at the coil value. A coil inductance (L) of 4.7 μH to 15 μH is recommended from viewpoints of electric power efficiency, response, and stability.

(2) Output Capacity Settings

For the capacitor to use for the output, select the capacitor which has the larger value in the ripple voltage V_{PP} allowance value and the drop voltage allowance value at the time of sudden load change. Output ripple voltage is decided by the following equation.

$$\Delta V_{PP} = I_{LMAX} \times R_{ESR} + \frac{1}{f C_o} \times \frac{V_{CC}}{V_o} \times \left(I_{LMAX} - \frac{\Delta I_L}{2} \right) \text{ [V]} \quad \text{Here, } f \text{ is the switching frequency.}$$

Perform setting so that the voltage is within the allowable ripple voltage range.

For the drop voltage during sudden load change; V_{DR} , please perform the rough calculation by the following equation.

$$V_{DR} = \frac{\Delta I}{C_o} \times 10 \mu\text{s} \text{ [V]}$$

However, 10 μs is the rough calculation value of the DC/DC response speed. Please set the capacitance considering the sufficient margin so that these two values are within the standard value range.

(3) Selecting the Input Capacitor

Since the peak current flows between the input and output at the DC/DC converter, a capacitor is required to install at the input side. For the reason, the low ESR capacitor is recommended as an input capacitor which has the value more than 10 μF and less than 100 $\text{m}\Omega$. If a capacitor out of this range is selected, the excessive ripple voltage is superposed on the input voltage; accordingly it may cause the malfunction of IC.

However these conditions may vary according to the load current, input voltage, output voltage, inductance and switching frequency. Be sure to perform the margin check using the actual product.

(4) Setting RC, CC of the Phase Compensation Circuit

In the current mode control, since the coil current is controlled, a pole (phase lag) made by the CR filter composed of the output capacitor and load resistor will be created in the low frequency range, and a zero (phase lead) by the output capacitor and ESR of capacitor will be created in the high frequency range. In this case, to cancel the pole of the power amplifier, it is easy to compensate by adding the zero point with C_c and R_c to the output from the error amp as shown in the illustration.

Open loop gain characteristics

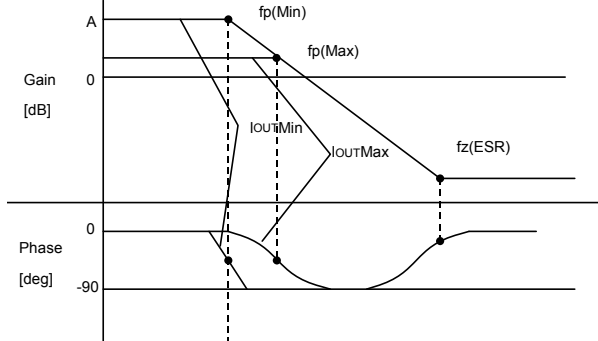

Error amp phase compensation characteristics

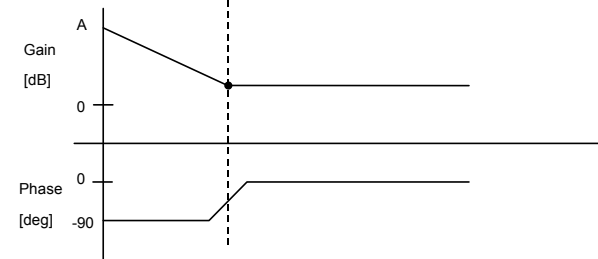

$$F_p = \frac{1}{2 \pi \times R_o \times C_o} \text{ [Hz]}$$

$$f_z(\text{ESR}) = \frac{1}{2 \pi \times \text{ESR} \times C_o} \text{ [Hz]}$$

Pole at the power amplification stage

When the output current reduces, the load resistance R_o increases and the pole frequency lowers.

$$f_p(\text{Min}) = \frac{1}{2 \pi \times R_{o\text{Max}} \times C_o} \text{ [Hz]} \leftarrow \text{ at light load}$$

$$f_z(\text{Max}) = \frac{1}{2 \pi \times R_{o\text{Min}} \times C_o} \text{ [Hz]} \leftarrow \text{ at heavy load}$$

Zero at the power amplification stage

When the output capacitor is set larger, the pole frequency lowers but the zero frequency will not change. (This is because the capacitor ESR becomes 1/2 when the capacitor becomes 2 times.)

$$f_p(\text{Amp.}) = \frac{1}{2 \pi \times R_c \times C_c} \text{ [Hz]}$$

Fig. 29 Gain vs Phase

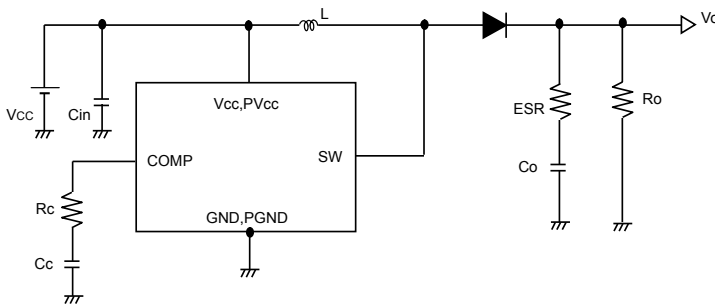

Fig. 30 Application Circuit Diagram

It is possible to realize the stable feedback loop by canceling the pole $f_p(\text{Min.})$, which is created by the output capacitor and load resistor, with CR zero compensation of the error amp as shown below.

$$f_z(\text{Amp.}) = f_p(\text{Min.})$$

$$\longrightarrow \frac{1}{2 \pi \times R_c \times C_c} = \frac{1}{2 \pi \times R_{o\text{max}} \times C_o} \text{ [Hz]}$$

(5) Regulator Controller Settings

The IC incorporates a 2.5 V regulator controller, and a regulator can be formed by using an external PNP transistor. Design the current capability of the regulator with a margin according to the following formula.

$$I_{OMAX} = 7mA \times hfe \quad [A]$$

The hfe is the current gain of the external PNP transistor. 7 mA is the sinking current of the internal transistor.

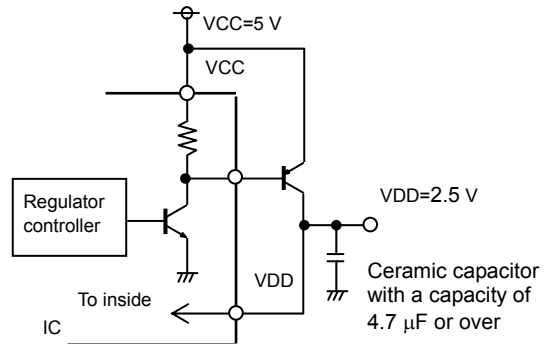

Fig.31

It is not necessary to use the regulator if the input voltage is 2.5 V. In that case, input 2.5 V to both VCC and VDD.

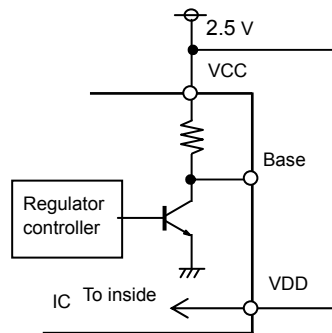

Fig.32

When incorporating a regulator into the external transistor, input the output voltage into the regulator.

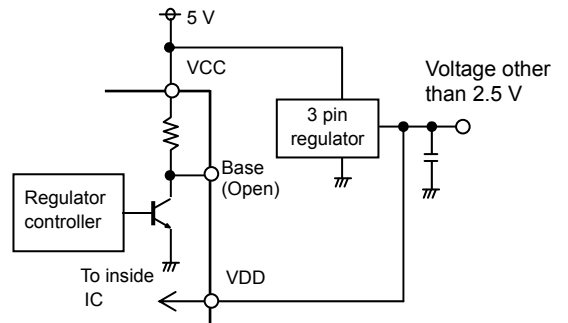

Fig.33

(6) Setting the Soft Start Time

Soft start is required to prevent the coil current at the time of start from increasing and the overshoot of the output voltage at the starting time. The relation between the capacity and soft start time is shown in the following figure. Refer to the figure and set capacity C1. Soft start is required to prevent the coil current at the time of start from increasing and the overshoot of the output voltage at the starting time. Fig. 34 shows the relation between the capacitance and soft start time. Please refer to it to set the capacitance.

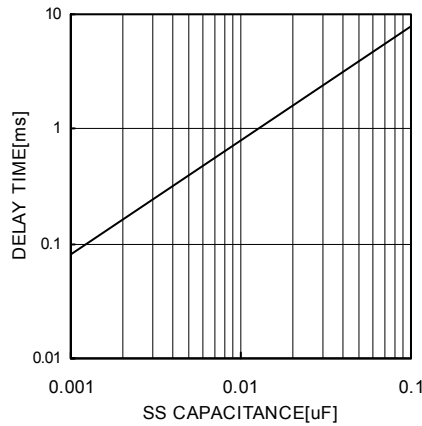

Fig. 34 SS Pin Capacitance vs Delay Time

As the capacitance, 0.001 μF to 0.1 μF is recommended. If the capacitance is set lower than 0.001 μF, the overshooting may occur on the output voltage. If the capacitance is set larger than 0.1 μF, the excessive back current flow may occur in the internal parasitic elements when the power is turned OFF and it may damage IC. When there is the activation relation (sequences) with other power supplies, be sure to use the high accuracy product (such as X5R). Soft start time may vary according to the input voltage, loads, coils and output capacity. Be sure to verify the operation using the actual product.

(7) Design of the Feedback Resistor Constant

Refer to the following equation to set the feedback resistor. As the setting range, 10 kΩ to 330 kΩ is recommended. If the resistor is set lower than a 10 kΩ, it causes the reduction of power efficiency. If it is set more than 330 kΩ, the offset voltage becomes larger by the input bias current 0.4 μA(Typ.) in the internal error amplifier.

$$V_o = \frac{R8 + R9}{R9} \times 1.24 \quad [V]$$

Sep-up

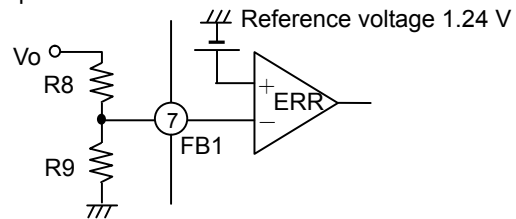

Fig. 35

(8) Positive-side Charge Pump Settings

The IC incorporates a charge pump controller, thus making it possible to generate stable gate voltage.

The output voltage is determined by the following formula. As the setting range, 10 kΩ to 330 kΩ is recommended. If the resistor is set lower than a 10kΩ, it causes the reduction of power efficiency. If it is set more than 330 kΩ, the offset voltage becomes larger by the input bias current 0.4 μA (Typ.) in the internal error amp.

$$V_o = \frac{R8 + R9}{R9} \times 1.24 \quad [V]$$

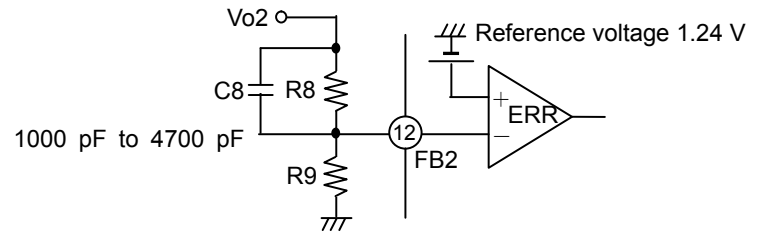

Fig. 36

In order to prevent output voltage overshooting, add capacitor C8 in parallel with R8. The recommended capacitance is 1000 pF to 4700 pF. If a capacitor outside this range is inserted, the output voltage may oscillate.

By connecting capacitance to the DLS, a rising delay time can be set for the positive-side charge pump. The delay time is determined by the following formula.

- Delay time of charge pump block t_{DELAY}

$$t_{\text{DELAY}} = (C_{\text{DLS}} \times 0.6) / 5 \mu\text{A} \quad [\text{s}]$$

where, C_{DLS} is the external capacitance.

(9) Negative-side Charge Pump Settings

This IC incorporates a charge pump controller for negative voltage, thus making it possible to generate stable gate voltage. The output voltage is determined by the following formula. As the setting range, 10 kΩ to 330 kΩ is recommended. If the resistor is set lower than a 10 kΩ, it causes the reduction of power efficiency. If it is set more than 330 kΩ, the offset voltage becomes larger by the input bias current 0.4 μA (Typ.) in the internal error amp.

$$V_{o3} = -\frac{R6}{R7} \times 1.04 + 0.2 \text{ V} \quad [V]$$

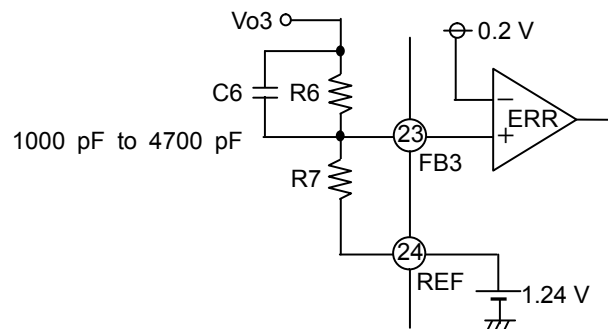

Fig.37

The delay time is internally fixed at 200 μs.

In order to prevent output voltage overshooting, insert capacitor C6 in parallel with R6. The recommended capacitance is 1000 pF to 4700 pF. If a capacitor outside this range is inserted, the output voltage may oscillate.

●Gate Shading Setting Method

The IG input signal allows the high-level and low-level control of the positive-side gate voltage. The slope of output can be set by the external RC. The recommended resistance set value is 200 Ω to 5.1 kΩ and the recommended capacitor set value is 0.001 μF to 0.1 μF. The aggravation of efficiency may be caused if settings outside this range are made. Determine ΔV by referring to the following value. The following calculation formula is used for ΔV.

$$\Delta V = V_{o2GS} \left(1 - \exp\left(- \frac{t_{WL}}{CR} \right) \right) \quad [V]$$

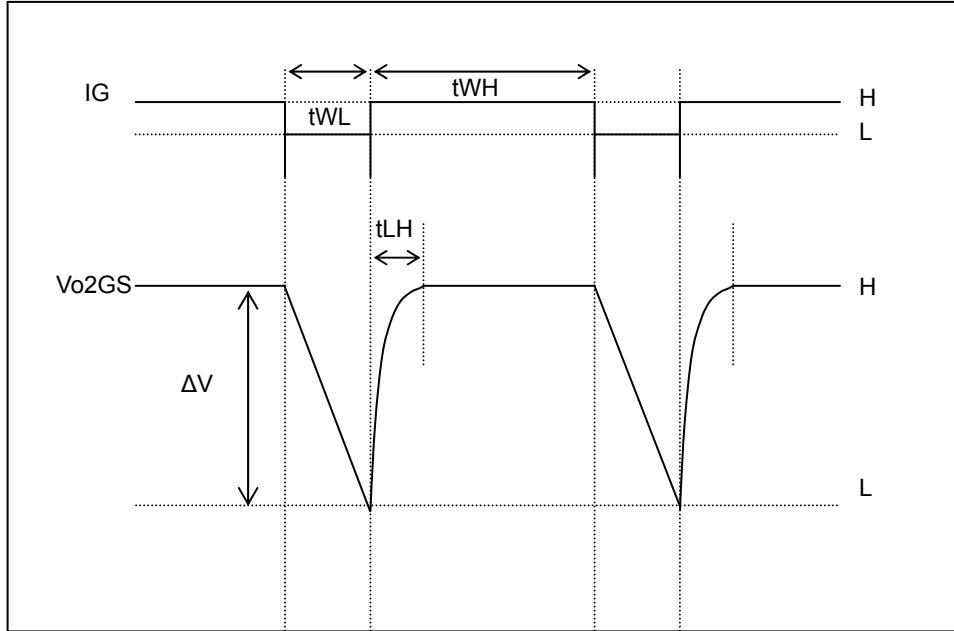

Fig. 38

TIMING STANDARD VALUE

Parameter	Symbol	Limits			Unit	Condition
		Min.	Typ.	Max.		
IG "L" Time	tWL	1	2	-	μs	-
IG "H" Time	tWH	1	18	-	μs	-
Vo2GS "H" to "L" Voltage difference	ΔV	-	10	-	V	TWL = 2 μs, R = 500 Ω *
Vo2GS "L" to "H" Time	tLH	-	0.1	-	μs	ΔV = 10 V *

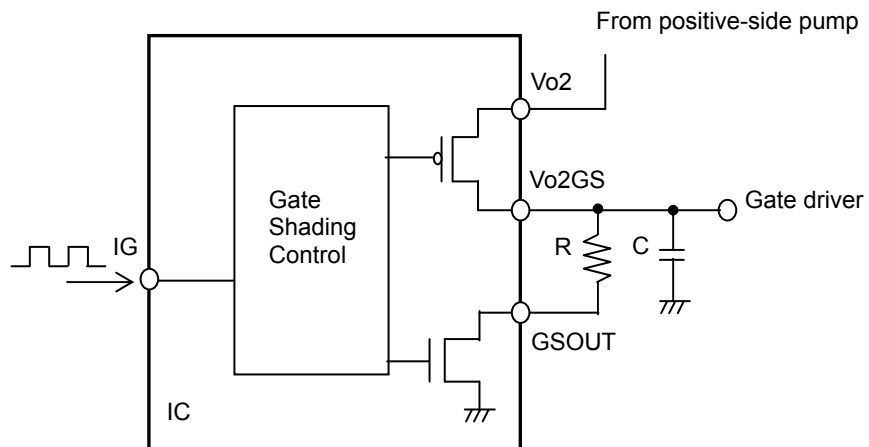

Fig. 39

●Application Examples

Although we are confident that the application circuit diagram reflects the best possible recommendations, be sure to verify circuit characteristics for your particular application. When a circuit is used modifying the externally connected circuit constant, be sure to decide allowing sufficient margins considering the dispersion of values by external parts as well as our IC including not only the static but also the transient characteristic. For the patent, we have not acquired the sufficient confirmation. Please acknowledge the status.

(a) Input voltage
5 V

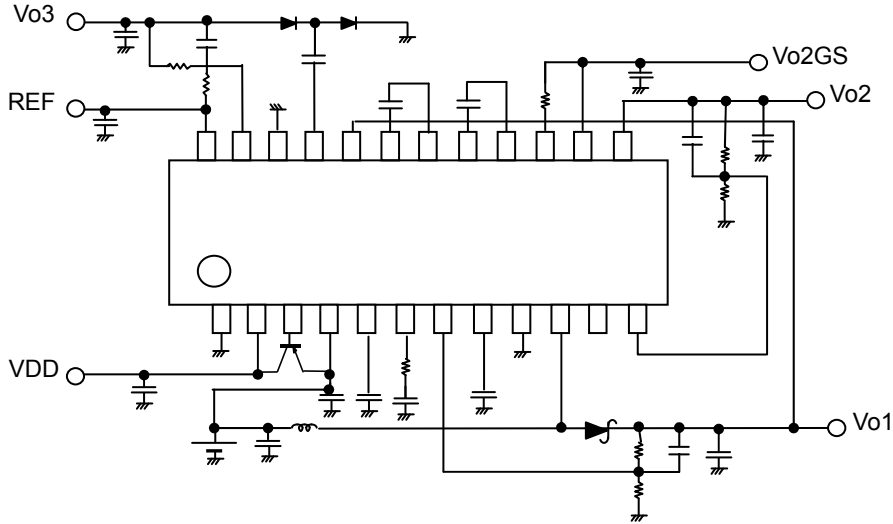

Fig. 40

(b) Input voltage
2.5 V

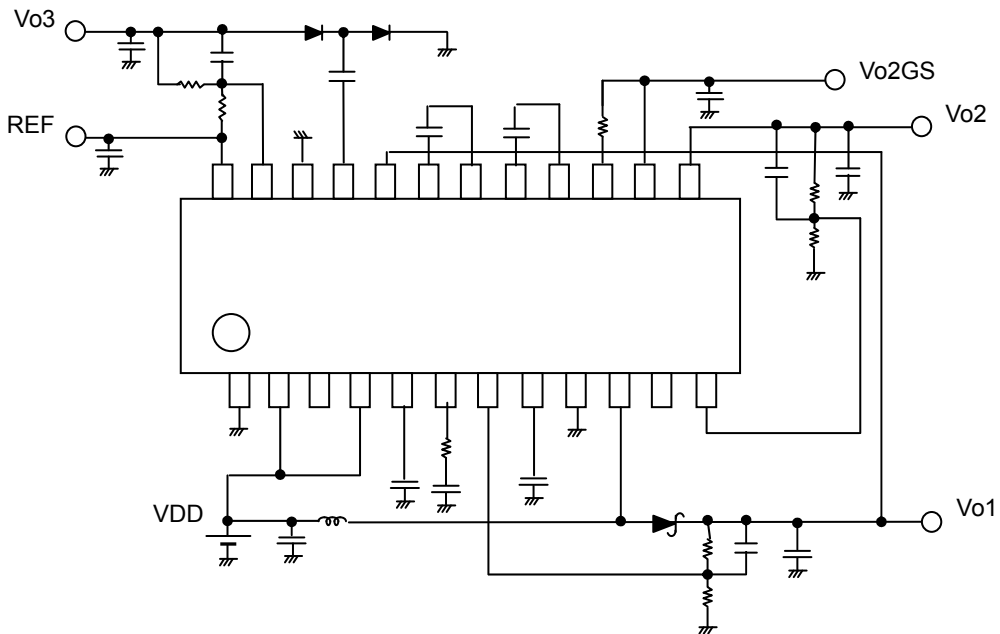

Fig. 41

(c) When Inserting PMOS Switch

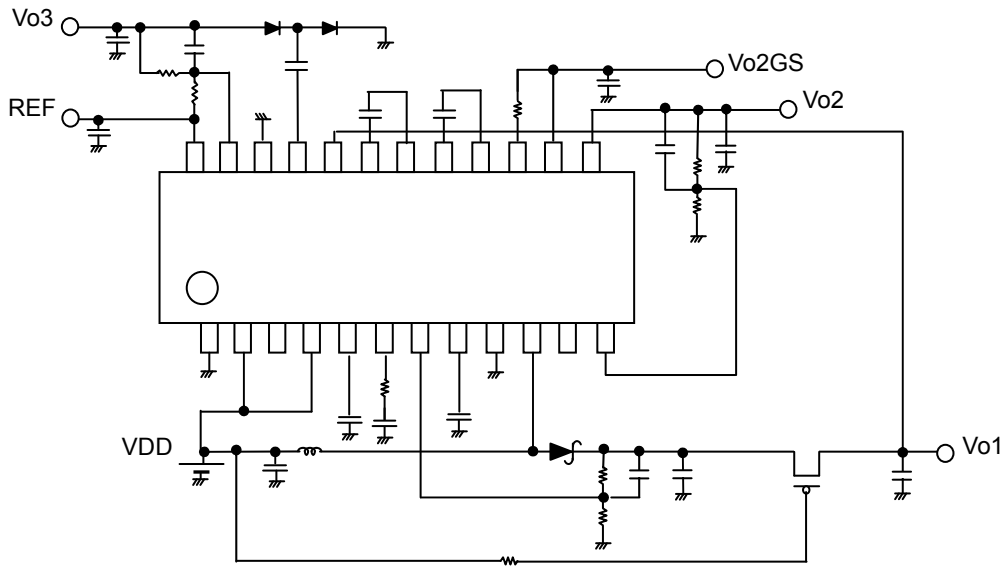

Fig. 42

● I/O Equivalent Circuits

<p>2.VDD</p> 	<p>3.BASE</p> 	<p>5.DLS,8.SS</p> 
<p>6.COMP</p> 	<p>7.FB1,12.FB2</p> 	<p>10.SW</p> 
<p>11.IG</p> 	<p>13.Vo2</p> 	<p>14.Vo2GS</p> 
<p>15.GSOUT</p> 	<p>16.C2H,19.C1H</p> 	<p>17.C2L,18.C1L,21.C3</p> 
<p>23.FB3</p> 	<p>24.REF</p> 	

Fig. 43

● Power Dissipation Reduction

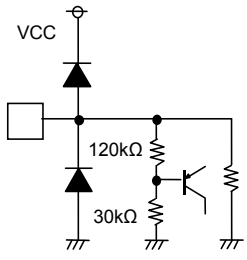
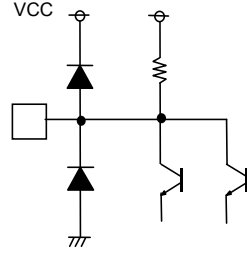
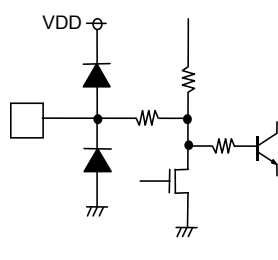
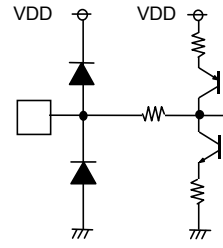
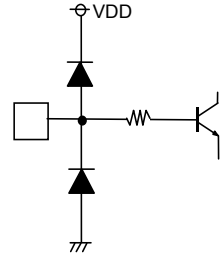
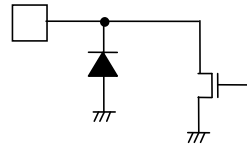
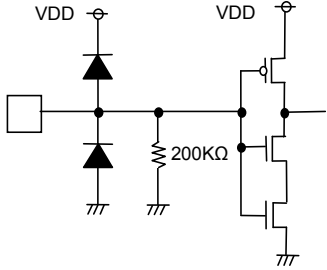
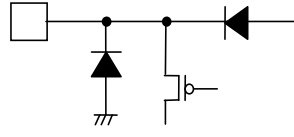
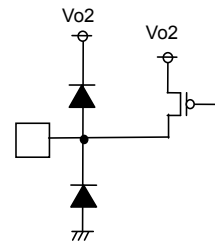
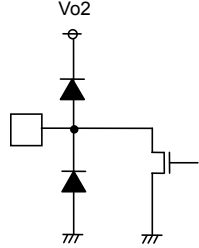
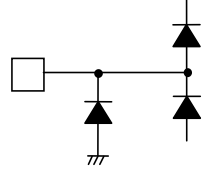
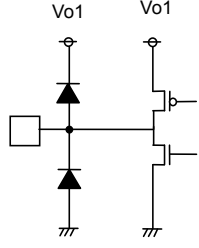
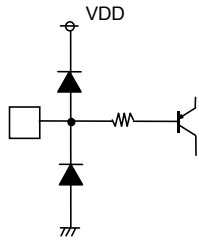
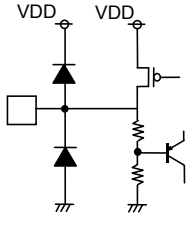
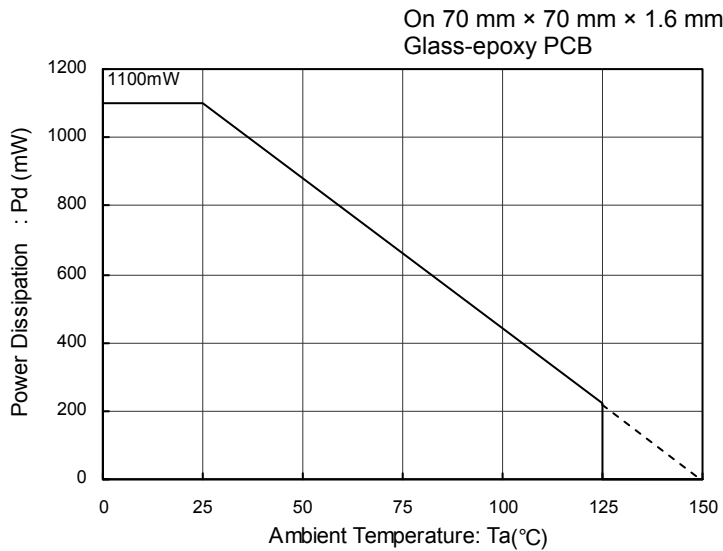

Fig.44

● Notes for use

- 1) Absolute maximum ratings
Use of the IC in excess of absolute maximum ratings such as the applied voltage or operating temperature range may result in IC damage. Assumptions should not be made regarding the state of the IC (short mode or open mode) when such damage is suffered. A physical safety measure such as a fuse should be implemented when use of the IC in a special mode where the absolute maximum ratings may be exceeded is anticipated.
- 2) GND potential
Ensure a minimum GND pin potential in all operating conditions.
- 3) Setting of heat
Use a thermal design that allows for a sufficient margin in light of the power dissipation (Pd) in actual operating conditions.
- 4) Pin short and mistake fitting
Use caution when orienting and positioning the IC for mounting on printed circuit boards. Improper mounting may result in damage to the IC. Shorts between output pins or between output pins and the power supply and GND pins caused by the presence of a foreign object may result in damage to the IC.
- 5) Actions in strong magnetic field
Use caution when using the IC in the presence of a strong magnetic field as doing so may cause the IC to malfunction.
- 6) Testing on application boards
When testing the IC on an application board, connecting a capacitor to a pin with low impedance subjects the IC to stress. Always discharge capacitors after each process or step. Ground the IC during assembly steps as an antistatic measure, and use similar caution when transporting or storing the IC. Always turn the IC's power supply off before connecting it to or removing it from a jig or fixture during the inspection process.
- 7) Ground wiring patterns
When using both small signal and large current GND patterns, it is recommended to isolate the two ground patterns, placing a single ground point at the application's reference point so that the pattern wiring resistance and voltage variations caused by large currents do not cause variations in the small signal ground voltage. Be careful not to change the GND wiring patterns of any external components.

- 8) This monolithic IC contains P+ isolation and P substrate layers between adjacent elements in order to keep them isolated. P/N junctions are formed at the intersection of these P layers with the N layers of other elements to create a variety of parasitic elements. For example, when the resistors and transistors are connected to the pins as shown in Fig.45, a parasitic diode or a transistor operates by inverting the pin voltage and GND voltage. The formation of parasitic elements as a result of the relationships of the potentials of different pins is an inevitable result of the IC's architecture. The operation of parasitic elements can cause interference with circuit operation as well as IC malfunction and damage. For these reasons, it is necessary to use caution so that the IC is not used in a way that will trigger the operation of parasitic elements, such as the application of voltages lower than the GND (P board) voltage to input and output pins.

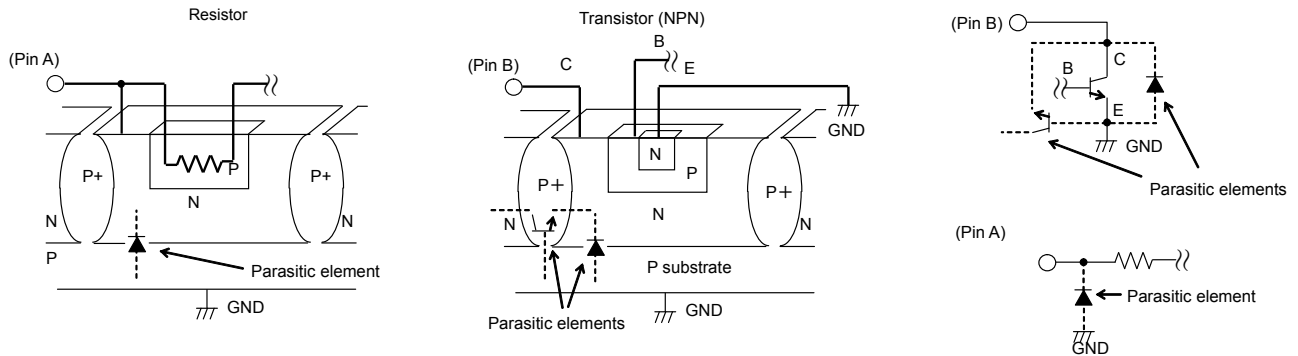

Fig.45 Example of a Simple Monolithic IC Architecture

9) Overcurrent protection circuits

An overcurrent protection circuit designed according to the output current is incorporated for the prevention of IC destruction that may result in the event of load shorting. This protection circuit is effective in preventing damage due to sudden and unexpected accidents. However, the IC should not be used in applications characterized by the continuous operation or transitioning of the protection circuits. At the time of thermal designing, keep in mind that the current capability has negative characteristics to temperatures.

10) Thermal shutdown circuit

This IC incorporates a built-in thermal shutdown circuit for the protection from thermal destruction. The IC should be used within the specified power dissipation range. However, in the event that the IC continues to be operated in excess of its power dissipation limits, the attendant rise in the chip's temperature T_j will trigger the thermal shutdown circuit to turn off all output power elements. The circuit automatically resets once the chip's temperature T_j drops.

Operation of the thermal shutdown circuit presumes that the IC's absolute maximum ratings have been exceeded. Application designs should never make use of the thermal shutdown circuit.

11) Testing on application boards

At the time of inspection of the installation boards, when the capacitor is connected to the pin with low impedance, be sure to discharge electricity per process because it may load stresses to the IC. Always turn the IC's power supply off before connecting it to or removing it from a jig or fixture during the inspection process. Ground the IC during assembly steps as an antistatic measure, and use similar caution when transporting or storing the IC.

●Ordering part number

B	D
---	---

Part No.

8	1	6	3
---	---	---	---

Part No.

E	F	V
---	---	---

Package
EFV: HTSSOP-B24

E	2
---	---

Packaging and forming specification
E2: Embossed tape and reel

HTSSOP-B24

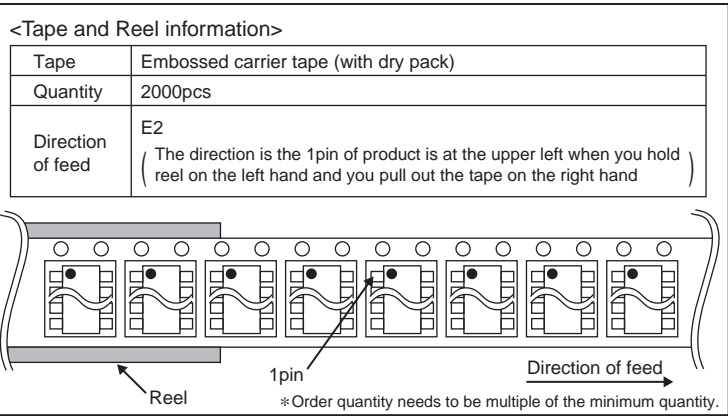
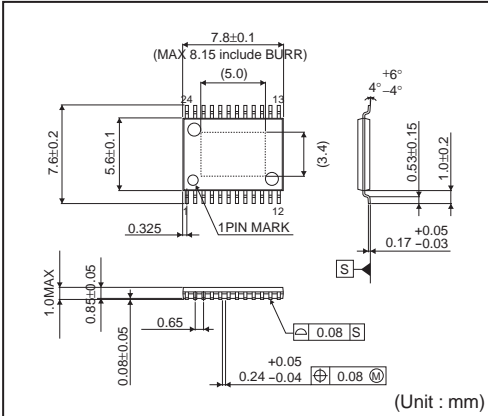

Notes

No copying or reproduction of this document, in part or in whole, is permitted without the consent of ROHM Co.,Ltd.

The content specified herein is subject to change for improvement without notice.

The content specified herein is for the purpose of introducing ROHM's products (hereinafter "Products"). If you wish to use any such Product, please be sure to refer to the specifications, which can be obtained from ROHM upon request.

Examples of application circuits, circuit constants and any other information contained herein illustrate the standard usage and operations of the Products. The peripheral conditions must be taken into account when designing circuits for mass production.

Great care was taken in ensuring the accuracy of the information specified in this document. However, should you incur any damage arising from any inaccuracy or misprint of such information, ROHM shall bear no responsibility for such damage.

The technical information specified herein is intended only to show the typical functions of and examples of application circuits for the Products. ROHM does not grant you, explicitly or implicitly, any license to use or exercise intellectual property or other rights held by ROHM and other parties. ROHM shall bear no responsibility whatsoever for any dispute arising from the use of such technical information.

The Products specified in this document are intended to be used with general-use electronic equipment or devices (such as audio visual equipment, office-automation equipment, communication devices, electronic appliances and amusement devices).

The Products specified in this document are not designed to be radiation tolerant.

While ROHM always makes efforts to enhance the quality and reliability of its Products, a Product may fail or malfunction for a variety of reasons.

Please be sure to implement in your equipment using the Products safety measures to guard against the possibility of physical injury, fire or any other damage caused in the event of the failure of any Product, such as derating, redundancy, fire control and fail-safe designs. ROHM shall bear no responsibility whatsoever for your use of any Product outside of the prescribed scope or not in accordance with the instruction manual.

The Products are not designed or manufactured to be used with any equipment, device or system which requires an extremely high level of reliability the failure or malfunction of which may result in a direct threat to human life or create a risk of human injury (such as a medical instrument, transportation equipment, aerospace machinery, nuclear-reactor controller, fuel-controller or other safety device). ROHM shall bear no responsibility in any way for use of any of the Products for the above special purposes. If a Product is intended to be used for any such special purpose, please contact a ROHM sales representative before purchasing.

If you intend to export or ship overseas any Product or technology specified herein that may be controlled under the Foreign Exchange and the Foreign Trade Law, you will be required to obtain a license or permit under the Law.



Thank you for your accessing to ROHM product informations.
More detail product informations and catalogs are available, please contact us.

ROHM Customer Support System

<http://www.rohm.com/contact/>

Компания «Океан Электроники» предлагает заключение долгосрочных отношений при поставках импортных электронных компонентов на взаимовыгодных условиях!

Наши преимущества:

- Поставка оригинальных импортных электронных компонентов напрямую с производств Америки, Европы и Азии, а так же с крупнейших складов мира;
- Широкая линейка поставок активных и пассивных импортных электронных компонентов (более 30 млн. наименований);
- Поставка сложных, дефицитных, либо снятых с производства позиций;
- Оперативные сроки поставки под заказ (от 5 рабочих дней);
- Экспресс доставка в любую точку России;
- Помощь Конструкторского Отдела и консультации квалифицированных инженеров;
- Техническая поддержка проекта, помощь в подборе аналогов, поставка прототипов;
- Поставка электронных компонентов под контролем ВП;
- Система менеджмента качества сертифицирована по Международному стандарту ISO 9001;
- При необходимости вся продукция военного и аэрокосмического назначения проходит испытания и сертификацию в лаборатории (по согласованию с заказчиком);
- Поставка специализированных компонентов военного и аэрокосмического уровня качества (Xilinx, Altera, Analog Devices, Intersil, Interpoint, Microsemi, Actel, Aeroflex, Peregrine, VPT, Syfer, Eurofarad, Texas Instruments, MS Kennedy, Miteq, Cobham, E2V, MA-COM, Hittite, Mini-Circuits, General Dynamics и др.);

Компания «Океан Электроники» является официальным дистрибьютором и эксклюзивным представителем в России одного из крупнейших производителей разъемов военного и аэрокосмического назначения «JONHON», а так же официальным дистрибьютором и эксклюзивным представителем в России производителя высокотехнологичных и надежных решений для передачи СВЧ сигналов «FORSTAR».



JONHON

«JONHON» (основан в 1970 г.)

Разъемы специального, военного и аэрокосмического назначения:

(Применяются в военной, авиационной, аэрокосмической, морской, железнодорожной, горно- и нефтедобывающей отраслях промышленности)

«FORSTAR» (основан в 1998 г.)

ВЧ соединители, коаксиальные кабели,
кабельные сборки и микроволновые компоненты:

(Применяются в телекоммуникациях гражданского и специального назначения, в средствах связи, РЛС, а так же военной, авиационной и аэрокосмической отраслях промышленности).



Телефон: 8 (812) 309-75-97 (многоканальный)

Факс: 8 (812) 320-03-32

Электронная почта: ocean@oceanchips.ru

Web: <http://oceanchips.ru/>

Адрес: 198099, г. Санкт-Петербург, ул. Калинина, д. 2, корп. 4, лит. А