



Is Now Part of



ON Semiconductor®

To learn more about ON Semiconductor, please visit our website at
www.onsemi.com

Please note: As part of the Fairchild Semiconductor integration, some of the Fairchild orderable part numbers will need to change in order to meet ON Semiconductor's system requirements. Since the ON Semiconductor product management systems do not have the ability to manage part nomenclature that utilizes an underscore (_), the underscore (_) in the Fairchild part numbers will be changed to a dash (-). This document may contain device numbers with an underscore (_). Please check the ON Semiconductor website to verify the updated device numbers. The most current and up-to-date ordering information can be found at www.onsemi.com. Please email any questions regarding the system integration to Fairchild_questions@onsemi.com.

ON Semiconductor and the ON Semiconductor logo are trademarks of Semiconductor Components Industries, LLC dba ON Semiconductor or its subsidiaries in the United States and/or other countries. ON Semiconductor owns the rights to a number of patents, trademarks, copyrights, trade secrets, and other intellectual property. A listing of ON Semiconductor's product/patent coverage may be accessed at www.onsemi.com/site/pdf/Patent-Marking.pdf. ON Semiconductor reserves the right to make changes without further notice to any products herein. ON Semiconductor makes no warranty, representation or guarantee regarding the suitability of its products for any particular purpose, nor does ON Semiconductor assume any liability arising out of the application or use of any product or circuit, and specifically disclaims any and all liability, including without limitation special, consequential or incidental damages. Buyer is responsible for its products and applications using ON Semiconductor products, including compliance with all laws, regulations and safety requirements or standards, regardless of any support or applications information provided by ON Semiconductor. "Typical" parameters which may be provided in ON Semiconductor data sheets and/or specifications can and do vary in different applications and actual performance may vary over time. All operating parameters, including "Typicals" must be validated for each customer application by customer's technical experts. ON Semiconductor does not convey any license under its patent rights nor the rights of others. ON Semiconductor products are not designed, intended, or authorized for use as a critical component in life support systems or any FDA Class 3 medical devices or medical devices with a same or similar classification in a foreign jurisdiction or any devices intended for implantation in the human body. Should Buyer purchase or use ON Semiconductor products for any such unintended or unauthorized application, Buyer shall indemnify and hold ON Semiconductor and its officers, employees, subsidiaries, affiliates, and distributors harmless against all claims, costs, damages, and expenses, and reasonable attorney fees arising out of, directly or indirectly, any claim of personal injury or death associated with such unintended or unauthorized use, even if such claim alleges that ON Semiconductor was negligent regarding the design or manufacture of the part. ON Semiconductor is an Equal Opportunity/Affirmative Action Employer. This literature is subject to all applicable copyright laws and is not for resale in any manner.

FSUSB40 — Low-Power, Two-Port, Hi-Speed, USB2.0 (480Mbps) Switch

Features

- Low On Capacitance: 5.9pF Typical
- Low On Resistance: 3.9Ω Typical
- Low Power Consumption: 1μA Maximum
 - 15μA Maximum I_{OCT} over an Expanded Voltage Range ($V_{IN}=1.8V$, $V_{CC}=4.3V$)
- Wide -3db Bandwidth: > 720MHz
- Packaged in:
 - 10-Lead MicroPak™ (1.6 x 2.1mm)
 - 10-Lead UMLP (1.4 x 1.8mm)
- 8kV ESD Rating, >16kV Power/GND ESD Rating
- Power-Off Protection on All Ports When $V_{CC}=0V$
 - D+/D- Pins Tolerate up to 5.25V
- Over-Voltage Tolerance (OVT) on all USB Ports Up to 5.25V without External Components

Applications

- Cell phone, PDA, Digital Camera, and Notebook
- LCD Monitor, TV, and Set-Top Box

IMPORTANT NOTE:

For additional performance information, please contact analogswitch@fairchildsemi.com.

Description

The FSUSB40 is a bi-directional, low-power, two-port, Hi-Speed, USB2.0 switch. Configured as a double-pole, double-throw switch (DPDT) switch, it is optimized for switching between two Hi-Speed (480Mbps) sources or a Hi-Speed and Full-Speed (12Mbps) source.

The FSUSB40 is compatible with the requirements of USB2.0 and features an extremely low on capacitance (C_{ON}) of 5.9pF. The wide bandwidth of this device (720MHz) exceeds the bandwidth needed to pass the third harmonic, resulting in signals with minimum edge and phase distortion. Superior channel-to-channel crosstalk also minimizes interference.

The FSUSB40 contains special circuitry on the switch I/O pins for applications where the V_{CC} supply is powered-off ($V_{CC}=0$), which allows the device to withstand an over-voltage condition. This device is designed to minimize current consumption even when the control voltage applied to the SEL pin is lower than the supply voltage (V_{CC}). This feature is especially valuable to ultra-portable applications, such as cell phones, allowing for direct interface with the general-purpose I/Os of the baseband processor. Other applications include switching and connector sharing in portable cell phones, PDAs, digital cameras, printers, and notebook computers.

Ordering Information

Part Number	Top Mark	Operating Temperature Range	 Eco Status	Package
FSUSB40L10X	HD	-40 to +85°C	RoHS	10-Lead MicroPak™ 1.6 x 2.1mm, JEDEC MO-255B
FSUSB40UMX	HC	-40 to +85°C	Green	10-Lead, Quad, Ultrathin Molded Leadless Package (UMLP), 1.4 x 1.8mm

MicroPak™ is a trademark of Fairchild Semiconductor Corporation.

 For Fairchild's definition of Eco Status, please visit: http://www.fairchildsemi.com/company/green/rohs_green.html.

Analog Symbol

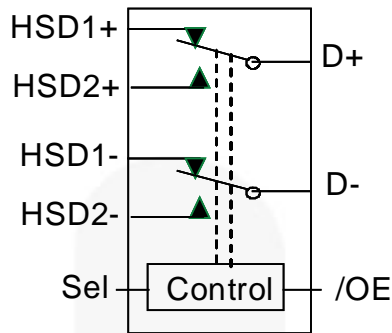

Figure 1. Analog Symbol

Pin Assignments

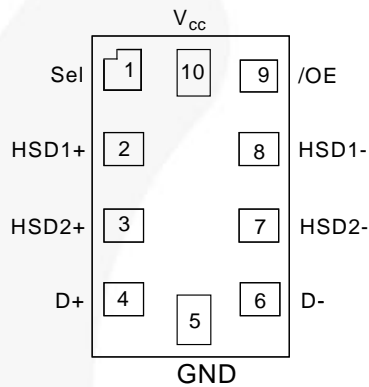

Figure 2. Pad Assignments for MicroPak™ (Top Through View)

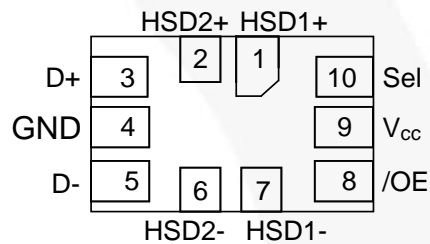

Figure 3. Pin Assignments for UMLP (Top Through View)

Pin Definitions

MicroPak™ Pin #	UMLP Pin #	Name	Description
9	8	/OE	Switch Enable
1	10	Sel	Switch Select
4, 6	3, 5	D+, D-	USB Data Bus
2, 3, 7, 8	1, 2, 6, 7	HSDn+, HSDn-	Multiplexed Source inputs
5	4	GND	Ground

Truth Table

Sel	/OE	Function
X	H	Disconnect
L	L	D+, D-=HSD1+, HSD1-
H	L	D+, D-=HSD2+, HSD2-

Absolute Maximum Ratings

Stresses exceeding the absolute maximum ratings may damage the device. The device may not function or be operable above the recommended operating conditions and stressing the parts to these levels is not recommended. In addition, extended exposure to stresses above the recommended operating conditions may affect device reliability. The absolute maximum ratings are stress ratings only.

Symbol	Parameter	Min.	Max.	Unit	
V_{CC}	Supply Voltage	-0.5	+5.5	V	
V_{CNTRL}	DC Input Voltage (S, /OE) ⁽¹⁾	-0.5	V_{CC}	V	
V_{SW}	DC Switch I/O Voltage ⁽¹⁾	-0.50	5.25	V	
I_{IK}	DC Input Diode Current	-50		mA	
I_{OUT}	DC Output Current		100	mA	
T_{STG}	Storage Temperature	-65	+150	°C	
ESD	Human Body Model, JEDEC: JESD22-A114	All Pins		7	kV
		I/O to GND		8	
		Power to GND		16	
	Charged Device Model, JEDEC: JESD22-C101			2	

Note:

- The input and output negative ratings may be exceeded if the input and output diode current ratings are observed.

Recommended Operating Conditions

The Recommended Operating Conditions table defines the conditions for actual device operation. Recommended operating conditions are specified to ensure optimal performance to the datasheet specifications. Fairchild does not recommend exceeding them or designing to Absolute Maximum Ratings.

Symbol	Parameter	Min.	Max.	Unit
V_{CC}	Supply Voltage	3.0	4.3	V
V_{CNTRL}	Control Input Voltage (S, /OE) ⁽²⁾	0	V_{CC}	V
V_{SW}	Switch I/O Voltage	-0.5	4.5	V
T_A	Operating Temperature	-40	+85	°C

Note:

- The control input must be held HIGH or LOW and it must not float.

DC Electrical Characteristics

All typical value are at 25°C unless otherwise specified.

Symbol	Parameter	Conditions	V _{CC} (V)	T _A =- 40°C to +85°C			Units
				Min.	Typ.	Max.	
V _{IK}	Clamp Diode Voltage	I _{IN} =-18mA	3.0			-1.2	V
V _{IH}	Input Voltage High		3.0 to 3.6	1.3			V
			4.3	1.7			V
V _{IL}	Input Voltage Low		3.0 to 3.6			0.5	V
			4.3			0.7	V
I _{IN}	Control Input Leakage	V _{SW} =0 to V _{CC}	4.3	-1		1	μA
I _{OZ}	Off State Leakage	0 ≤ Dn, HSD1n, HSD2n ≤ 3.6V	4.3	-2		2	μA
I _{OFF}	Power-Off Leakage Current (All I/O Ports)	V _{SW} =0V to 4.3V, V _{CC} =0V Figure 5	0	-2		2	μA
R _{ON}	HS Switch On Resistance ⁽³⁾	V _{SW} =0.4V, I _{ON} =-8mA Figure 4	3.0		3.9	6.5	Ω
ΔR _{ON}	HS Delta Ron ⁽⁴⁾	V _{SW} =0.4V, I _{ON} =-8mA	3.0		0.65		Ω
I _{CC}	Quiescent Supply Current	V _{CNTRL} =0 or V _{CC} , I _{OUT} =0	4.3			1.0	μA
I _{CCT}	Increase in I _{CC} Current Per Control Voltage and V _{CC}	V _{CNTRL} =2.6V V _{CC} =4.3V	4.3			10.0	μA
		V _{CNTRL} =1.8V V _{CC} =4.3V	4.3			15.0	μA

Notes:

3. Measured by the voltage drop between HSDn and Dn pins at the indicated current through the switch. On resistance is determined by the lower of the voltage on the two (HSDn or Dn ports).
4. Guaranteed by characterization.

AC Electrical Characteristics

All typical value are for $V_{CC}=3.3V$ at $25^{\circ}C$ unless otherwise specified.

Symbol	Parameter	Conditions	V_{CC} (V)	$T_A=-40^{\circ}C$ to $+85^{\circ}C$			Units
				Min.	Typ.	Max.	
t_{ON}	Turn-On Time S, /OE to Output	$R_L=50\Omega$, $C_L=5pF$ $V_{SW}=0.8V$ Figure 6, Figure 7	3.0 to 3.6		13	30	ns
t_{OFF}	Turn-Off Time S, /OE to Output	$R_L=50\Omega$, $C_L=5pF$ $V_{SW}=0.8V$ Figure 6, Figure 7	3.0 to 3.6		12	25	ns
t_{PD}	Propagation Delay ⁽⁵⁾	$C_L=5 pF$, $R_L=50\Omega$ Figure 6, Figure 8	3.3		0.25		ns
t_{BBM}	Break-Before-Make	$R_L=50\Omega$, $C_L=5pF$ $V_{SW1}=V_{SW2}=0.8V$ Figure 12	3.0 to 3.6	2.0		6.5	ns
O_{IRR}	Off Isolation	$R_L=50\Omega$, $f=240MHz$ Figure 14	3.0 to 3.6		-30		dB
Xtalk	Non-Adjacent Channel Crosstalk	$R_L=50\Omega$, $f=240MHz$ Figure 15	3.0 to 3.6		-45		dB
BW	-3db Bandwidth	$R_L=50\Omega$, $C_L=0pF$ Figure 13	3.0 to 3.6		720		MHz
		$R_L=50\Omega$, $C_L=5pF$ Figure 13			550		MHz

Note:

5. Guaranteed by characterization.

USB Hi-Speed-Related AC Electrical Characteristics

Symbol	Parameter	Conditions	V_{CC} (V)	$T_A=-40^{\circ}C$ to $+85^{\circ}C$			Units
				Min.	Typ.	Max.	
$t_{SK(P)}$	Skew of Opposite Transitions of the Same Output ⁽⁶⁾	$C_L=5pF$, $R_L=50\Omega$ Figure 9	3.0 to 3.6		20		ps
t_j	Total Jitter ⁽⁶⁾	$R_L=50\Omega$, $C_L=5pf$, $t_R=t_F=500ps$ (10-90%) at 480Mbps (PRBS= $2^{15} - 1$)	3.0 to 3.6		200		ps

Note:

6. Guaranteed by characterization.

Capacitance

Symbol	Parameter	Conditions	$T_A=-40^{\circ}C$ to $+85^{\circ}C$			Units
			Min.	Typ.	Max.	
C_{IN}	Control Pin Input Capacitance	$V_{CC}=0V$		1.5		pF
C_{ON}	D+/D- On Capacitance	$V_{CC}=3.3V$, /OE=0V, $f=1MHz$ Figure 11		5.9	6.5	
C_{OFF}	D1n, D2n Off Capacitance	V_{CC} and /OE=3.3V Figure 10		2.0		

Test Diagrams

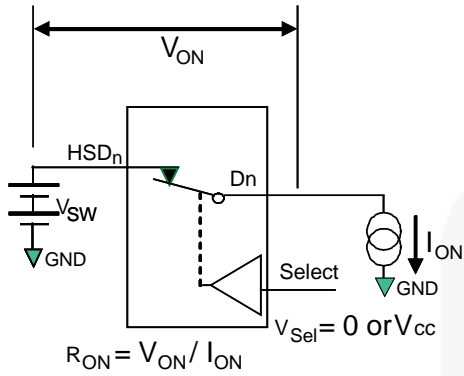
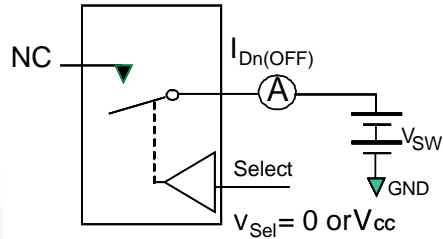
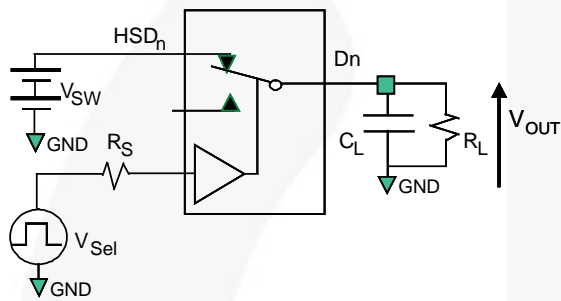

Figure 4. On Resistance



**Each switch port is tested separately

Figure 5. Off Leakage



R_L , R_S , and C_L are functions of the application environment (see AC Tables for specific values)
 C_L includes test fixture and stray capacitance.

Figure 6. AC Test Circuit Load

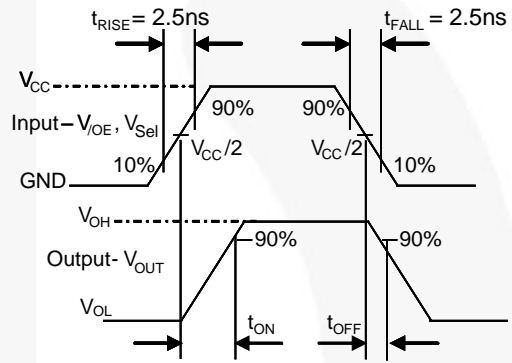

Figure 7. Turn-On / Turn-Off Waveforms

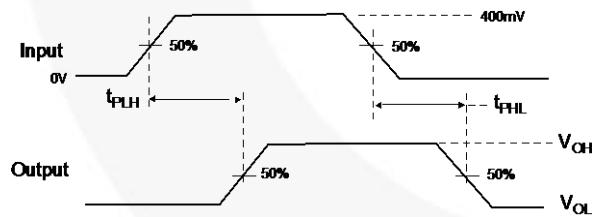

Figure 8. Propagation Delay ($t_R, t_F - 500ps$)

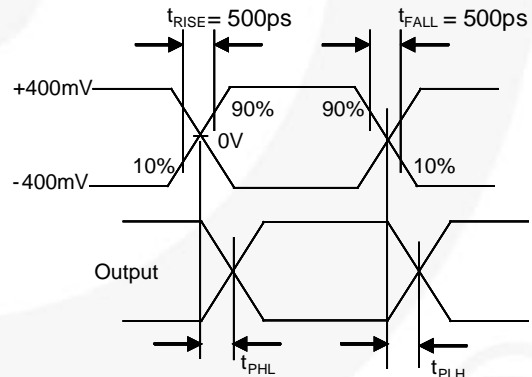

Figure 9. Intra-Pair Skew Test $t_{SK(P)}$

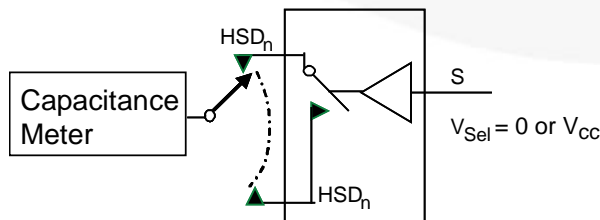

Figure 10. Channel Off Capacitance

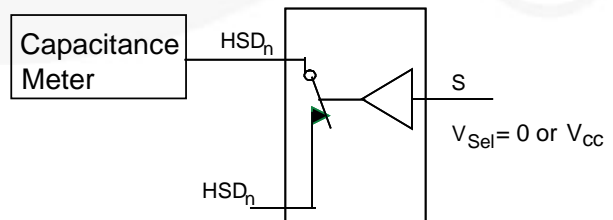
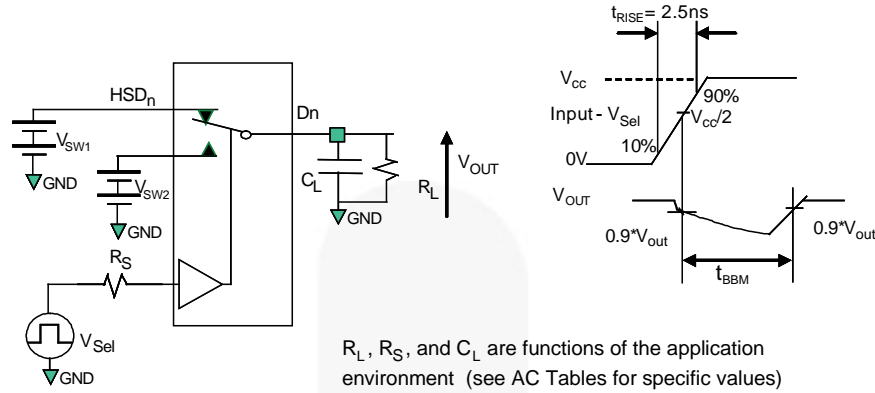

Figure 11. Channel On Capacitance

Test Diagrams (Continued)



R_L , R_S , and C_L are functions of the application environment (see AC Tables for specific values)
 C_L includes test fixture and stray capacitance.

Figure 12. Break-Before-Make Interval Timing

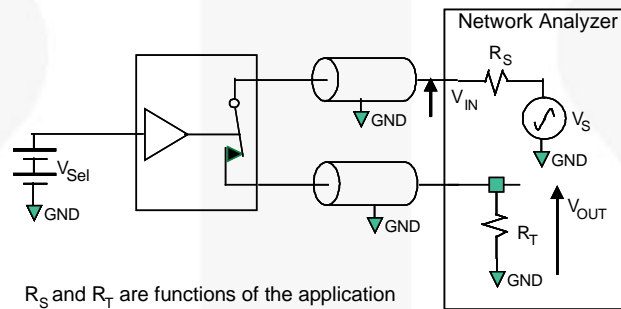

R_S and R_T are functions of the application environment (see AC Tables for specific values).

Figure 13. Bandwidth

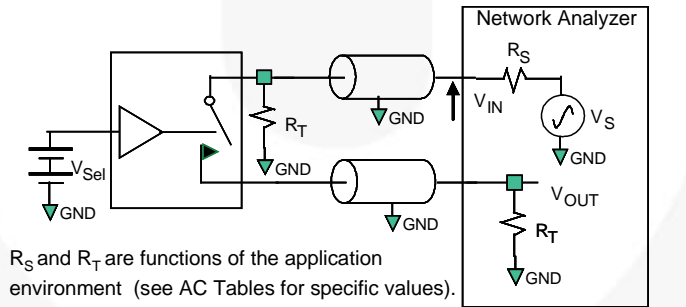

R_S and R_T are functions of the application environment (see AC Tables for specific values).

$$\text{Off isolation} = 20 \text{ Log } (V_{OUT} / V_{IN})$$

Figure 14. Channel Off Isolation

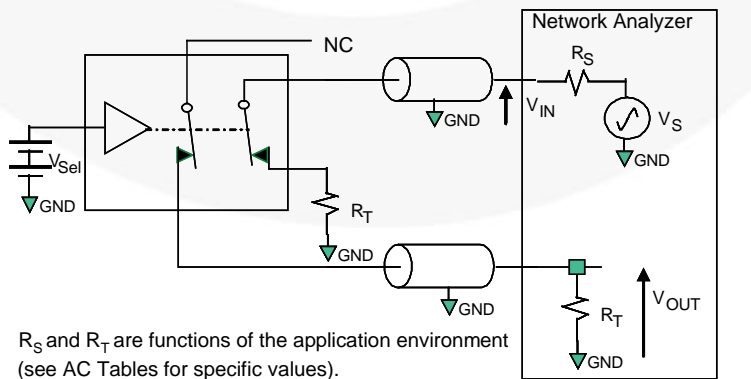

R_S and R_T are functions of the application environment (see AC Tables for specific values).

$$\text{Crosstalk} = 20 \text{ Log } (V_{OUT} / V_{IN})$$

Figure 15. Non-Adjacent Channel-to-Channel Crosstalk

Physical Dimensions

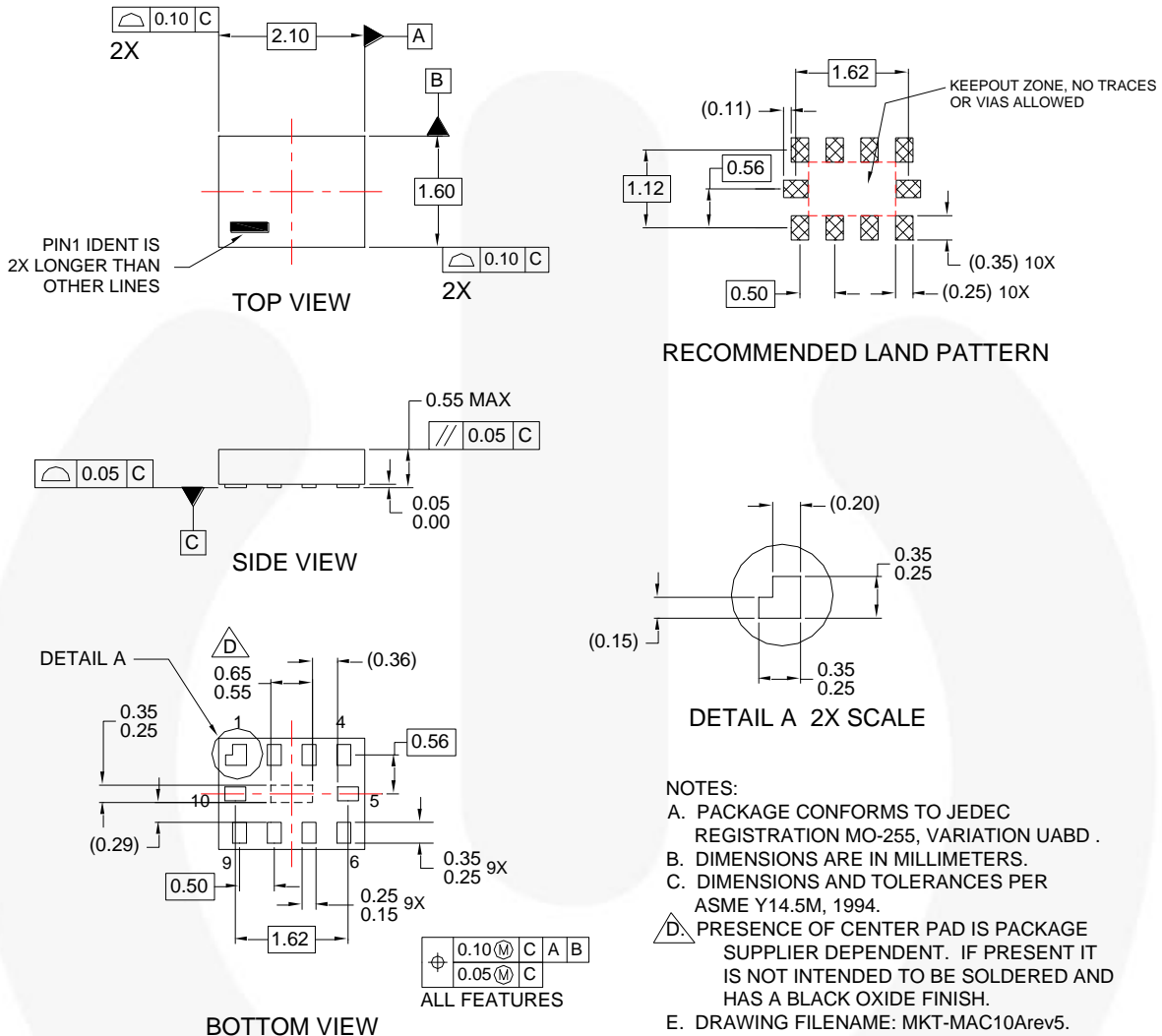
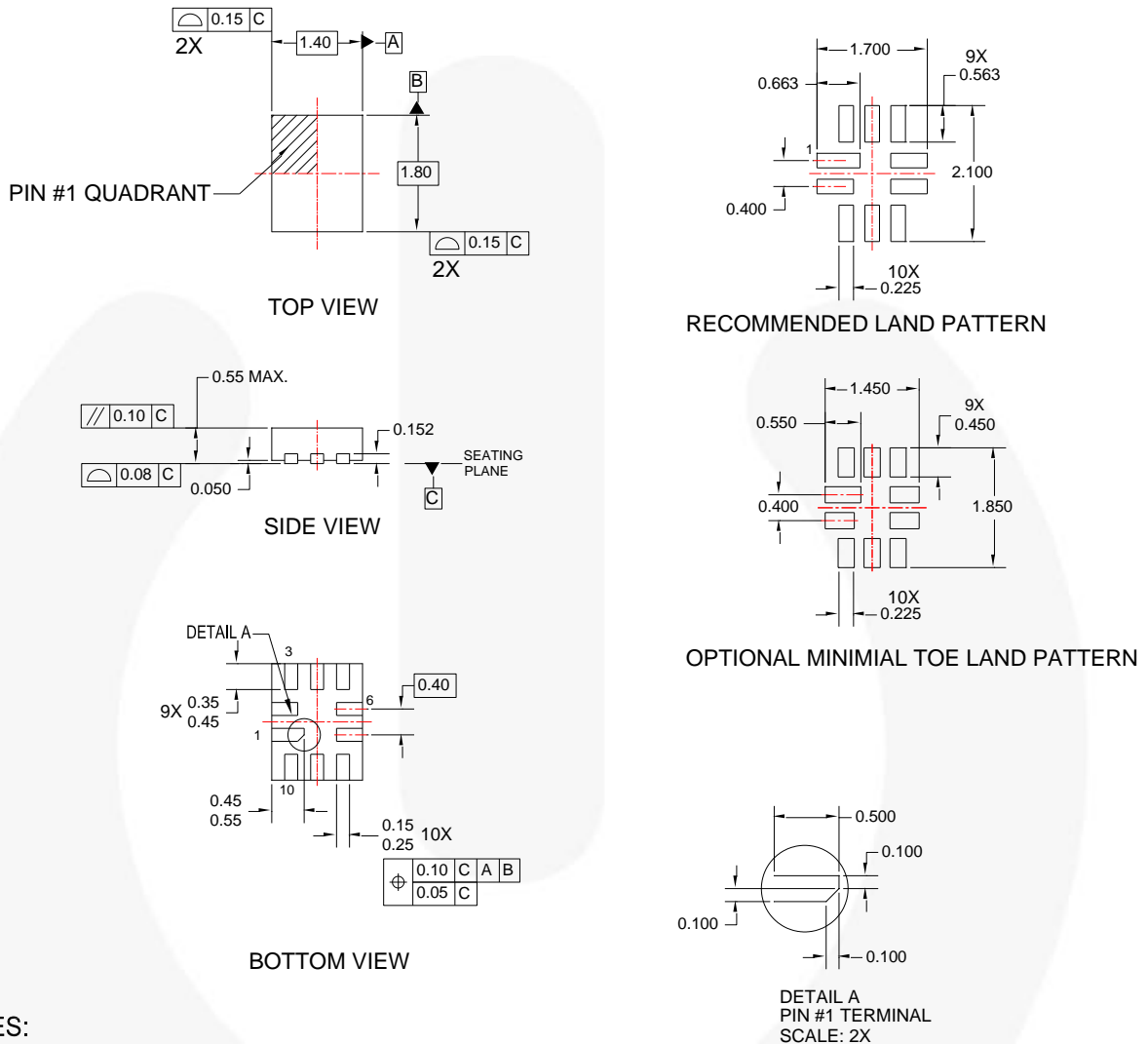

Figure 16. 10-Lead MicroPak™

Package drawings are provided as a service to customers considering Fairchild components. Drawings may change in any manner without notice. Please note the revision and/or date on the drawing and contact a Fairchild Semiconductor representative to verify or obtain the most recent revision. Package specifications do not expand the terms of Fairchild's worldwide terms and conditions, specifically the warranty therein, which covers Fairchild products.

Always visit Fairchild Semiconductor's online packaging area for the most recent package drawings:
<http://www.fairchildsemi.com/packaging/>.

Physical Dimensions



NOTES:

- A. DIMENSIONS ARE IN MILLIMETERS.
- B. DIMENSIONS AND TOLERANCES PER ASME Y14.5M, 1994
- C. DRAWING FILENAME: UMLP10Arev2

Figure 17. 10-Lead, Ultrathin Molded Leadless Package (UMLP)

Package drawings are provided as a service to customers considering Fairchild components. Drawings may change in any manner without notice. Please note the revision and/or date on the drawing and contact a Fairchild Semiconductor representative to verify or obtain the most recent revision. Package specifications do not expand the terms of Fairchild's worldwide terms and conditions, specifically the warranty therein, which covers Fairchild products.

Always visit Fairchild Semiconductor's online packaging area for the most recent package drawings:
<http://www.fairchildsemi.com/packaging/>



TRADEMARKS

The following includes registered and unregistered trademarks and service marks, owned by Fairchild Semiconductor and/or its global subsidiaries, and is not intended to be an exhaustive list of all such trademarks.

- | | | | |
|--------------------------|--------------------------|---------------------------------------|--|
| AccuPower™ | FlashWriter®* | Power-SPM™ | <p>SYSTEM GENERAL
The Power Franchise®</p> <p>the power franchise</p> <p>TinyBoost™</p> <p>TinyBuck™</p> <p>TinyCalc™</p> <p>TinyLogic®</p> <p>TINYOPTO™</p> <p>TinyPower™</p> <p>TinyPWM™</p> <p>TinyWire™</p> <p>TriFault Detect™</p> <p>SPM®</p> <p>TRUECURRENT™*</p> <p>µSerDes™</p> <p>SerDes™</p> <p>UHC®</p> <p>Ultra FRFET™</p> <p>UniFET™</p> <p>VCX™</p> <p>VisualMax™</p> <p>XST™</p> |
| Auto-SPM™ | FPS™ | PowerTrench® | |
| Build it Now™ | F-PFS™ | PowerXS™ | |
| CorePLUS™ | FRFET® | Programmable Active Droop™ | |
| CorePOWER™ | Global Power Resource SM | QFET® | |
| CROSSVOLT™ | Green FPST™ | QST™ | |
| CTL™ | Green FPST™ e-Series™ | Quiet Series™ | |
| Current Transfer Logic™ | Gmax™ | RapidConfigure™ | |
| DEUXPEED® | GTO™ | ™ | |
| EcoSPARK® | IntelliMAX™ | Saving our world, 1mV/W/kW at a time™ | |
| EfficientMax™ | ISOPLANAR™ | SignalWise™ | |
| EZSWITCH™** | MegaBuck™ | SmartMax™ | |
| ™** | MICROCOUPLER™ | SMART START™ | |
| ™ | MicroFET™ | SPM® | |
| Fairchild® | MicroPak™ | STEALTH™ | |
| Fairchild Semiconductor® | MillerDrive™ | SuperFET™ | |
| FACT Quiet Series™ | MotionMax™ | SuperSOT™-3 | |
| FACT® | Motion-SPM™ | SuperSOT™-6 | |
| FAST® | OPTOLOGIC® | SuperSOT™-8 | |
| FastvCore™ | OPTOPLANAR® | SupreMOS™ | |
| FETBench™ | ™ | SyncFET™ | |
| | PDP SPM™ | Sync-Lock™ | |

* Trademarks of System General Corporation, used under license by Fairchild Semiconductor.

DISCLAIMER

FAIRCHILD SEMICONDUCTOR RESERVES THE RIGHT TO MAKE CHANGES WITHOUT FURTHER NOTICE TO ANY PRODUCTS HEREIN TO IMPROVE RELIABILITY, FUNCTION, OR DESIGN. FAIRCHILD DOES NOT ASSUME ANY LIABILITY ARISING OUT OF THE APPLICATION OR USE OF ANY PRODUCT OR CIRCUIT DESCRIBED HEREIN; NEITHER DOES IT CONVEY ANY LICENSE UNDER ITS PATENT RIGHTS, NOR THE RIGHTS OF OTHERS. THESE SPECIFICATIONS DO NOT EXPAND THE TERMS OF FAIRCHILD'S WORLDWIDE TERMS AND CONDITIONS, SPECIFICALLY THE WARRANTY THEREIN, WHICH COVERS THESE PRODUCTS.

LIFE SUPPORT POLICY

FAIRCHILD'S PRODUCTS ARE NOT AUTHORIZED FOR USE AS CRITICAL COMPONENTS IN LIFE SUPPORT DEVICES OR SYSTEMS WITHOUT THE EXPRESS WRITTEN APPROVAL OF FAIRCHILD SEMICONDUCTOR CORPORATION.

As used herein:

1. Life support devices or systems are devices or systems which, (a) are intended for surgical implant into the body or (b) support or sustain life, and (c) whose failure to perform when properly used in accordance with instructions for use provided in the labeling, can be reasonably expected to result in a significant injury of the user.
2. A critical component in any component of a life support, device, or system whose failure to perform can be reasonably expected to cause the failure of the life support device or system, or to affect its safety or effectiveness.

ANTI-COUNTERFEITING POLICY

Fairchild Semiconductor Corporation's Anti-Counterfeiting Policy. Fairchild's Anti-Counterfeiting Policy is also stated on our external website, www.fairchildsemi.com, under Sales Support.

Counterfeiting of semiconductor parts is a growing problem in the industry. All manufacturers of semiconductor products are experiencing counterfeiting of their parts. Customers who inadvertently purchase counterfeit parts experience many problems such as loss of brand reputation, substandard performance, failed applications, and increased cost of production and manufacturing delays. Fairchild is taking strong measures to protect ourselves and our customers from the proliferation of counterfeit parts. Fairchild strongly encourages customers to purchase Fairchild parts either directly from Fairchild or from Authorized Fairchild Distributors who are listed by country on our web page cited above. Products customers buy either from Fairchild directly or from Authorized Fairchild Distributors are genuine parts, have full traceability, meet Fairchild's quality standards for handling and storage and provide access to Fairchild's full range of up-to-date technical and product information. Fairchild and our Authorized Distributors will stand behind all warranties and will appropriately address any warranty issues that may arise. Fairchild will not provide any warranty coverage or other assistance for parts bought from Unauthorized Sources. Fairchild is committed to combat this global problem and encourage our customers to do their part in stopping this practice by buying direct or from authorized distributors.

PRODUCT STATUS DEFINITIONS

Definition of Terms

Datasheet Identification	Product Status	Definition
Advance Information	Formative / In Design	Datasheet contains the design specifications for product development. Specifications may change in any manner without notice.
Preliminary	First Production	Datasheet contains preliminary data; supplementary data will be published at a later date. Fairchild Semiconductor reserves the right to make changes at any time without notice to improve design.
No Identification Needed	Full Production	Datasheet contains final specifications. Fairchild Semiconductor reserves the right to make changes at any time without notice to improve the design.
Obsolete	Not In Production	Datasheet contains specifications on a product that is discontinued by Fairchild Semiconductor. The datasheet is for reference information only.

Rev. I44

ON Semiconductor and  are trademarks of Semiconductor Components Industries, LLC dba ON Semiconductor or its subsidiaries in the United States and/or other countries. ON Semiconductor owns the rights to a number of patents, trademarks, copyrights, trade secrets, and other intellectual property. A listing of ON Semiconductor's product/patent coverage may be accessed at www.onsemi.com/site/pdf/Patent-Marking.pdf. ON Semiconductor reserves the right to make changes without further notice to any products herein. ON Semiconductor makes no warranty, representation or guarantee regarding the suitability of its products for any particular purpose, nor does ON Semiconductor assume any liability arising out of the application or use of any product or circuit, and specifically disclaims any and all liability, including without limitation special, consequential or incidental damages. Buyer is responsible for its products and applications using ON Semiconductor products, including compliance with all laws, regulations and safety requirements or standards, regardless of any support or applications information provided by ON Semiconductor. "Typical" parameters which may be provided in ON Semiconductor data sheets and/or specifications can and do vary in different applications and actual performance may vary over time. All operating parameters, including "Typicals" must be validated for each customer application by customer's technical experts. ON Semiconductor does not convey any license under its patent rights nor the rights of others. ON Semiconductor products are not designed, intended, or authorized for use as a critical component in life support systems or any FDA Class 3 medical devices or medical devices with a same or similar classification in a foreign jurisdiction or any devices intended for implantation in the human body. Should Buyer purchase or use ON Semiconductor products for any such unintended or unauthorized application, Buyer shall indemnify and hold ON Semiconductor and its officers, employees, subsidiaries, affiliates, and distributors harmless against all claims, costs, damages, and expenses, and reasonable attorney fees arising out of, directly or indirectly, any claim of personal injury or death associated with such unintended or unauthorized use, even if such claim alleges that ON Semiconductor was negligent regarding the design or manufacture of the part. ON Semiconductor is an Equal Opportunity/Affirmative Action Employer. This literature is subject to all applicable copyright laws and is not for resale in any manner.

PUBLICATION ORDERING INFORMATION

LITERATURE FULFILLMENT:

Literature Distribution Center for ON Semiconductor
19521 E. 32nd Pkwy, Aurora, Colorado 80011 USA
Phone: 303-675-2175 or 800-344-3860 Toll Free USA/Canada
Fax: 303-675-2176 or 800-344-3867 Toll Free USA/Canada
Email: orderlit@onsemi.com

N. American Technical Support: 800-282-9855 Toll Free
USA/Canada
Europe, Middle East and Africa Technical Support:
Phone: 421 33 790 2910
Japan Customer Focus Center
Phone: 81-3-5817-1050

ON Semiconductor Website: www.onsemi.com
Order Literature: <http://www.onsemi.com/orderlit>
For additional information, please contact your local
Sales Representative

Mouser Electronics

Authorized Distributor

Click to View Pricing, Inventory, Delivery & Lifecycle Information:

[ON Semiconductor:](#)

[FSUSB40UMX](#) [FSUSB40L10X](#)

Компания «Океан Электроники» предлагает заключение долгосрочных отношений при поставках импортных электронных компонентов на взаимовыгодных условиях!

Наши преимущества:

- Поставка оригинальных импортных электронных компонентов напрямую с производств Америки, Европы и Азии, а так же с крупнейших складов мира;
- Широкая линейка поставок активных и пассивных импортных электронных компонентов (более 30 млн. наименований);
- Поставка сложных, дефицитных, либо снятых с производства позиций;
- Оперативные сроки поставки под заказ (от 5 рабочих дней);
- Экспресс доставка в любую точку России;
- Помощь Конструкторского Отдела и консультации квалифицированных инженеров;
- Техническая поддержка проекта, помощь в подборе аналогов, поставка прототипов;
- Поставка электронных компонентов под контролем ВП;
- Система менеджмента качества сертифицирована по Международному стандарту ISO 9001;
- При необходимости вся продукция военного и аэрокосмического назначения проходит испытания и сертификацию в лаборатории (по согласованию с заказчиком);
- Поставка специализированных компонентов военного и аэрокосмического уровня качества (Xilinx, Altera, Analog Devices, Intersil, Interpoint, Microsemi, Actel, Aeroflex, Peregrine, VPT, Syfer, Eurofarad, Texas Instruments, MS Kennedy, Miteq, Cobham, E2V, MA-COM, Hittite, Mini-Circuits, General Dynamics и др.);

Компания «Океан Электроники» является официальным дистрибьютором и эксклюзивным представителем в России одного из крупнейших производителей разъемов военного и аэрокосмического назначения «JONHON», а так же официальным дистрибьютором и эксклюзивным представителем в России производителя высокотехнологичных и надежных решений для передачи СВЧ сигналов «FORSTAR».



JONHON

«JONHON» (основан в 1970 г.)

Разъемы специального, военного и аэрокосмического назначения:

(Применяются в военной, авиационной, аэрокосмической, морской, железнодорожной, горно- и нефтедобывающей отраслях промышленности)

«FORSTAR» (основан в 1998 г.)

ВЧ соединители, коаксиальные кабели, кабельные сборки и микроволновые компоненты:

(Применяются в телекоммуникациях гражданского и специального назначения, в средствах связи, РЛС, а так же военной, авиационной и аэрокосмической отраслях промышленности).



Телефон: 8 (812) 309-75-97 (многоканальный)

Факс: 8 (812) 320-03-32

Электронная почта: ocean@oceanchips.ru

Web: <http://oceanchips.ru/>

Адрес: 198099, г. Санкт-Петербург, ул. Калинина, д. 2, корп. 4, лит. А