

FEATURES

- Supports up to 17 MHz SPI clock speed
- 4 high speed, low propagation delay, SPI signal isolation channels
- Supports up to 4 slave devices
- 20-lead SSOP package with 5.1 mm creepage
- High temperature operation: 125°C
- High common-mode transient immunity: >25 kV/μs
- Safety and regulatory approvals**
 - UL recognition per UL 1577
 - 3750 V rms for 1 minute
 - CSA Component Acceptance Notice 5A
 - VDE certificate of conformity
 - DIN V VDE V 0884-10 (VDE V 0884-10):2006-12
 - V_{IORM} = 565 V peak

APPLICATIONS

- Industrial programmable logic controllers (PLCs)
- Sensor isolation

GENERAL DESCRIPTION

The ADuM3154¹ is an SPI Isolator™ digital isolator optimized for a serial peripheral interface (SPI) that includes support for up to four slave devices. Based on the Analog Devices, Inc., iCoupler® chip scale transformer technology, the low propagation delay and jitter in the CLK, MO/SI, MI/SO, and \overline{SS} SPI bus signals support SPI clock rates of up to 17 MHz.

The ADuM3154 isolator also provides a slave select multiplexing system that allows up to four slave devices to be serviced from one isolator. When a target slave is selected, the slave select signal propagates to the desired output with low propagation delay, allowing tight timing control. The isolated SSx is addressed through a 250 kbps low speed, 2-channel address bus, allowing the target slave device to be changed in as little as 2.5 μs.

FUNCTIONAL BLOCK DIAGRAM

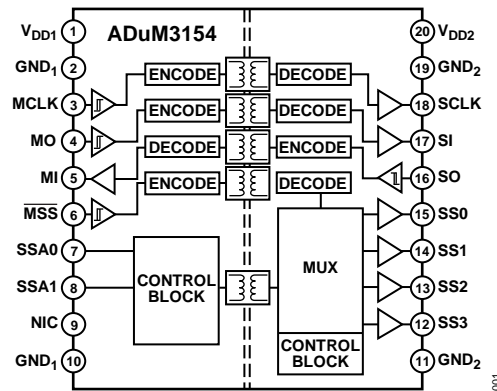

Figure 1.

Table 1. Related Products

Product	Description
ADuM3150	3.75 kV, high speed, clock delayed SPI isolator
ADuM3151/ADuM3152/ ADuM3153	3.75 kV, multichannel SPI isolator
ADuM4150	5 kV, high speed, clock delayed SPI isolator
ADuM4151/ADuM4152/ ADuM4153	5 kV, multichannel SPI isolator
ADuM4154	5 kV, multiple slave SPI isolator

¹Protected by U.S. Patents 5,952,849; 6,262,600; 6,873,065; and 7,075,329. Other patents are pending.

TABLE OF CONTENTS

Features	1	Recommended Operating Conditions	12
Applications.....	1	Absolute Maximum Ratings	13
Functional Block Diagram	1	ESD Caution.....	13
General Description	1	Pin Configuration and Function Descriptions.....	14
Revision History	2	Typical Performance Characteristics	16
Specifications.....	3	Applications Information	17
Electrical Characteristics—5 V Operation.....	3	Introduction	17
Electrical Characteristics—3.3 V Operation	5	Printed Circuit Board (PCB) Layout	19
Electrical Characteristics—Mixed 5 V/3.3 V Operation	7	Propagation Delay Related Parameters	19
Electrical Characteristics—Mixed 3.3 V/5 V Operation	9	DC Correctness and Magnetic Field Immunity.....	19
Package Characteristics	10	Power Consumption	20
Regulatory Information.....	11	Insulation Lifetime	20
Insulation and Safety Related Specifications	11	Outline Dimensions	22
DIN V VDE V 0884-10 (VDE V 0884-10):2006-12 Insulation Characteristics	12	Ordering Guide	22

REVISION HISTORY

7/2017—Rev. A to Rev. B

Changes to Output Voltages Parameter, Table 5.....	6
Changes to Output Voltages Parameter, Table 7.....	8
Changes to Output Voltages Parameter, Table 9.....	10

3/2015—Rev. 0 to Rev. A

Changes to Features Section and Table 1	1
Changes to Supply Current Parameter, Table 3	4
Changes to Supply Current Parameter, Table 5	6
Changes to Supply Current Parameter, Table 7	8
Changes to Supply Current Parameter, Table 9 and Table 10... ..	10
Changes to Table 11.....	11
Changes to Table 13 and Figure 2.....	12
Changes to High Speed Channels Section	17
Changes to Ordering Guide	22

7/2014—Revision 0: Initial Version

SPECIFICATIONS

ELECTRICAL CHARACTERISTICS—5 V OPERATION

All typical specifications are at $T_A = 25^\circ\text{C}$ and $V_{DD1} = V_{DD2} = 5\text{ V}$. Minimum and maximum specifications apply over the entire recommended operation range: $4.5\text{ V} \leq V_{DD1} \leq 5.5\text{ V}$, $4.5\text{ V} \leq V_{DD2} \leq 5.5\text{ V}$, and $-40^\circ\text{C} \leq T_A \leq +125^\circ\text{C}$, unless otherwise noted. Switching specifications are tested with $C_L = 15\text{ pF}$ and CMOS signal levels, unless otherwise noted.

Table 2. Switching Specifications

Parameter	Symbol	A Grade			B Grade			Unit	Test Conditions/Comments
		Min	Typ	Max	Min	Typ	Max		
MCLK, MO, SO									
SPI Clock Rate	SPI_{MCLK}			1			17	MHz	
Data Rate Fast (MO, SO)	DR_{FAST}			2			34	Mbps	Within PWD limit
Propagation Delay	t_{PHL}, t_{PLH}			25	12	14		ns	50% input to 50% output
Pulse Width	PW	100			12.5			ns	Within PWD limit
Pulse Width Distortion	PWD			2			2	ns	$ t_{PLH} - t_{PHL} $
Codirectional Channel Matching ¹	t_{PSKCD}			2			2	ns	
Jitter, High Speed	J_{HS}		1			1		ns	
MSS									
Data Rate Fast	DR_{FAST}			2			34	Mbps	Within PWD limit
Propagation Delay	t_{PHL}, t_{PLH}		21	26		21	26	ns	50% input to 50% output
Pulse Width	PW	100			12.5			ns	Within PWD limit
Pulse Width Distortion	PWD			3			3	ns	$ t_{PLH} - t_{PHL} $
Setup Time ²	\overline{MSS}_{SETUP}	1.5			10			ns	
Jitter, High Speed	J_{HS}		1			1		ns	
SSA0, SSA1									
Data Rate Slow	DR_{SLOW}			250			250	kbps	Within PWD limit
Propagation Delay	t_{PHL}, t_{PLH}	0.1		2.6	0.1		2.6	μs	50% input to 50% output
Pulse Width	PW	4			4			μs	Within PWD limit
Jitter, Low Speed	J_{LS}			2.5			2.5	μs	
SSAx ³ Minimum Input Skew ⁴	$t_{SSAX\ SKEW}^3$	40			40			ns	

¹ Codirectional channel matching is the absolute value of the difference in propagation delays between any two channels with inputs on the same side of the isolation barrier.

² The MSS signal is glitch filtered in both speed grades, whereas the other fast signals are not glitch filtered in the B grade. To guarantee that MSS reaches the output ahead of another fast signal, set up \overline{MSS} prior to the competing signal by different times depending on speed grade.

³ SSAx = SSA1 or SSA2.

⁴ An internal asynchronous clock, not available to users, samples the low speed signals. If edge sequence in codirectional channels is critical to the end application, the leading pulse must be at least $1\ t_{SSAX\ SKEW}$ ahead of a later pulse to guarantee the correct order or simultaneous arrival at the output.

Table 3. For All Models^{1, 2, 3}

Parameter	Symbol	Min	Typ	Max	Unit	Test Conditions/Comments
SUPPLY CURRENT						
A Grade and B Grade	I _{DD1}		4.8	8.5	mA	C _L = 0 pF, DR _{FAST} = 1 MHz, DR _{SLOW} = 0 MHz
	I _{DD2}		6.5	13	mA	C _L = 0 pF, DR _{FAST} = 1 MHz, DR _{SLOW} = 0 MHz
B Grade	I _{DD1}		10	18	mA	C _L = 0 pF, DR _{FAST} = 17 MHz, DR _{SLOW} = 0 MHz
	I _{DD2}		13.5	19	mA	C _L = 0 pF, DR _{FAST} = 17 MHz, DR _{SLOW} = 0 MHz
DC SPECIFICATIONS						
MCLK, $\overline{\text{MSS}}$, MO, SO, SSA0, SSA1						
Input Threshold						
Logic High	V _{IH}	0.7 × V _{DDx}			V	
Logic Low	V _{IL}			0.3 × V _{DDx}	V	
Input Hysteresis	V _{IHYST}		500		mV	
Input Current per Channel	I _I	-1	+0.01	+1	μA	0 V ≤ V _{INPUT} ≤ V _{DDx}
SCLK, MI, SI, SS0, SS1, SS2, SS3						
Output Voltages						
Logic High	V _{OH}	V _{DDx} - 0.1	5.0		V	I _{OUTPUT} = -20 μA, V _{INPUT} = V _{IH}
		V _{DDx} - 0.4	4.8		V	I _{OUTPUT} = -4 mA, V _{INPUT} = V _{IH}
Logic Low	V _{OL}		0.0	0.1	V	I _{OUTPUT} = 20 μA, V _{INPUT} = V _{IL}
			0.2	0.4	V	I _{OUTPUT} = 4 mA, V _{INPUT} = V _{IL}
V _{DD1} , V _{DD2} Undervoltage Lockout	UVLO			2.6	V	
Supply Current for High Speed Channels						
Dynamic Input	I _{DDI(D)}		0.080		mA/Mbps	
Dynamic Output	I _{DDO(D)}		0.046		mA/Mbps	
Supply Current for All Low Speed Channels						
Quiescent Input	I _{DD1(Q)}		4.2		mA	
Quiescent Output	I _{DD2(Q)}		6.1		mA	
AC SPECIFICATIONS						
Output Rise/Fall Time	t _R /t _F		2.5		ns	10% to 90%
Common-Mode Transient Immunity ⁴	CM	25	35		kV/μs	V _{INPUT} = V _{DDx} , V _{CM} = 1000 V, transient magnitude = 800 V

¹ V_{DDx} = V_{DD1} or V_{DD2}.² V_{INPUT} is the input voltage of any of the MCLK, $\overline{\text{MSS}}$, MO, SO, SSA0, or SSA1 pins.³ I_{OUTPUT} is the output current of any of the SCLK, MI, SI, SS0, SS1, SS2, or SS3 pins.⁴ |CM| is the maximum common-mode voltage slew rate that can be sustained while maintaining output voltages within the V_{OH} and V_{OL} limits. The common-mode voltage slew rates apply to both rising and falling common-mode voltage edges.

ELECTRICAL CHARACTERISTICS—3.3 V OPERATION

All typical specifications are at $T_A = 25^\circ\text{C}$ and $V_{DD1} = V_{DD2} = 3.3\text{ V}$. Minimum and maximum specifications apply over the entire recommended operation range: $3.0\text{ V} \leq V_{DD1} \leq 3.6\text{ V}$, $3.0\text{ V} \leq V_{DD2} \leq 3.6\text{ V}$, and $-40^\circ\text{C} \leq T_A \leq +125^\circ\text{C}$, unless otherwise noted. Switching specifications are tested with $C_L = 15\text{ pF}$ and CMOS signal levels, unless otherwise noted.

Table 4. Switching Specifications

Parameter	Symbol	A Grade			B Grade			Unit	Test Conditions/Comments
		Min	Typ	Max	Min	Typ	Max		
MCLK, MO, SO									
SPI Clock Rate	SPI_{MCLK}			1			12.5	MHz	
Data Rate Fast (MO, SO)	DR_{FAST}			2			34	Mbps	Within PWD limit
Propagation Delay	t_{PHL}, t_{PLH}			30			21	ns	50% input to 50% output
Pulse Width	PW	100			12.5			ns	Within PWD limit
Pulse Width Distortion	PWD			3			2	ns	$ t_{PLH} - t_{PHL} $
Codirectional Channel Matching ¹	t_{PSKCD}			3			2	ns	
Jitter, High Speed	J_{HS}		1			1		ns	
MSS									
Data Rate Fast	DR_{FAST}			2			34	Mbps	Within PWD limit
Propagation Delay	t_{PHL}, t_{PLH}			34			34	ns	50% input to 50% output
Pulse Width	PW	100			12.5			ns	Within PWD limit
Pulse Width Distortion	PWD			3			3	ns	$ t_{PLH} - t_{PHL} $
Setup Time ²	\overline{MSS}_{SETUP}	1.5			10			ns	
Jitter, High Speed	J_{HS}		1			1		ns	
SSA0, SSA1									
Data Rate Slow	DR_{SLOW}			250			250	kbps	Within PWD limit
Propagation Delay	t_{PHL}, t_{PLH}	0.1		2.6	0.1		2.6	μs	50% input to 50% output
Pulse Width	PW	4			4			μs	Within PWD limit
Jitter, Low Speed	J_{LS}			2.5			2.5	μs	
SSAx ³ Minimum Input Skew ⁴	$t_{SSAX_SKEW}^3$	40			40			ns	

¹ Codirectional channel matching is the absolute value of the difference in propagation delays between any two channels with inputs on the same side of the isolation barrier.

² The \overline{MSS} signal is glitch filtered in both speed grades, whereas the other fast signals are not glitch filtered in the B grade. To guarantee that \overline{MSS} reaches the output ahead of another fast signal, set up \overline{MSS} prior to the competing signal by different times depending on speed grade.

³ SSAx = SSA1 or SSA2.

⁴ An internal asynchronous clock, not available to users, samples the low speed signals. If edge sequence in codirectional channels is critical to the end application, the leading pulse must be at least $1 t_{SSAX_SKEW}$ ahead of a later pulse to guarantee the correct order or simultaneous arrival at the output.

Table 5. For All Models^{1, 2, 3}

Parameter	Symbol	Min	Typ	Max	Unit	Test Conditions/Comments
SUPPLY CURRENT						
A Grade and B Grade	I _{DD1}		3.4	6.5	mA	C _L = 0 pF, DR _{FAST} = 1 MHz, DR _{SLOW} = 0 MHz
	I _{DD2}		5	9	mA	C _L = 0 pF, DR _{FAST} = 1 MHz, DR _{SLOW} = 0 MHz
B Grade	I _{DD1}		11.7	15	mA	C _L = 0 pF, DR _{FAST} = 17 MHz, DR _{SLOW} = 0 MHz
	I _{DD2}		10	14	mA	C _L = 0 pF, DR _{FAST} = 17 MHz, DR _{SLOW} = 0 MHz
DC SPECIFICATIONS						
MCLK, $\overline{\text{MSS}}$, MO, SO, SSA0, SSA1						
Input Threshold						
Logic High	V _{IH}	0.7 × V _{DDx}			V	
Logic Low	V _{IL}			0.3 × V _{DDx}	V	
Input Hysteresis	V _{IHYST}		500		mV	
Input Current per Channel	I _I	-1	+0.01	+1	μA	0 V ≤ V _{INPUT} ≤ V _{DDx}
SCLK, MI, SI, SS0, SS1, SS2, SS3						
Output Voltages						
Logic High	V _{OH}	V _{DDx} - 0.1	3.3		V	I _{OUTPUT} = -20 μA, V _{INPUT} = V _{IH}
		V _{DDx} - 0.4	3.1		V	I _{OUTPUT} = -4 mA, V _{INPUT} = V _{IH}
Logic Low	V _{OL}		0.0	0.1	V	I _{OUTPUT} = 20 μA, V _{INPUT} = V _{IL}
			0.2	0.4	V	I _{OUTPUT} = 4 mA, V _{INPUT} = V _{IL}
V _{DD1} , V _{DD2} Undervoltage Lockout	UVLO		2.6		V	
Supply Current for High Speed Channels						
Dynamic Input	I _{DDI(D)}		0.078		mA/Mbps	
Dynamic Output	I _{DDO(D)}		0.026		mA/Mbps	
Supply Current for All Low Speed Channels						
Quiescent Input	I _{DD1(Q)}		2.9		mA	
Quiescent Output	I _{DD2(Q)}		4.7		mA	
AC SPECIFICATIONS						
Output Rise/Fall Time	t _R /t _F		2.5		ns	10% to 90%
Common-Mode Transient Immunity ⁴	CM	25	35		kV/μs	V _{INPUT} = V _{DDx} , V _{CM} = 1000 V, transient magnitude = 800 V

¹ V_{DDx} = V_{DD1} or V_{DD2}.² V_{INPUT} is the input voltage of any of the MCLK, $\overline{\text{MSS}}$, MO, SO, SSA0, or SSA1 pins.³ I_{OUTPUT} is the output current of any of the SCLK, MI, SI, SS0, SS1, SS2, or SS3 pins.⁴ |CM| is the maximum common-mode voltage slew rate that can be sustained while maintaining output voltages within the V_{OH} and V_{OL} limits. The common-mode voltage slew rates apply to both rising and falling common-mode voltage edges.

ELECTRICAL CHARACTERISTICS—MIXED 5 V/3.3 V OPERATION

All typical specifications are at $T_A = 25^\circ\text{C}$ and $V_{DD1} = 5\text{ V}$, $V_{DD2} = 3.3\text{ V}$. Minimum and maximum specifications apply over the entire recommended operation range: $4.5\text{ V} \leq V_{DD1} \leq 5.5\text{ V}$, $3.0\text{ V} \leq V_{DD2} \leq 3.6\text{ V}$, and $-40^\circ\text{C} \leq T_A \leq +125^\circ\text{C}$, unless otherwise noted. Switching specifications are tested with $C_L = 15\text{ pF}$ and CMOS signal levels, unless otherwise noted.

Table 6. Switching Specifications

Parameter	Symbol	A Grade			B Grade			Unit	Test Conditions/Comments
		Min	Typ	Max	Min	Typ	Max		
MCLK, MO, SO									
SPI Clock Rate	SPI_{MCLK}			1			15.6	MHz	
Data Rate Fast (MO, SO)	DR_{FAST}			2			34	Mbps	Within PWD limit
Propagation Delay	t_{PHL}, t_{PLH}			27			17	ns	50% input to 50% output
Pulse Width	PW	25			12.5			ns	Within PWD limit
Pulse Width Distortion	PWD			2			2	ns	$ t_{PLH} - t_{PHL} $
Codirectional Channel Matching ¹	t_{PSKCD}			2			2	ns	
Jitter, High Speed	J_{HS}		1			1		ns	
MSS									
Data Rate Fast	DR_{FAST}			2			34	Mbps	Within PWD limit
Propagation Delay	t_{PHL}, t_{PLH}			30			30	ns	50% input to 50% output
Pulse Width	PW	25			12.5			ns	Within PWD limit
Pulse Width Distortion	PWD			2			2	ns	$ t_{PLH} - t_{PHL} $
Setup Time ²	\overline{MSS}_{SETUP}	1.5			10			ns	
Jitter, High Speed	J_{HS}		1			1		ns	
SSA0, SSA1									
Data Rate Slow	DR_{SLOW}			250			250	kbps	Within PWD limit
Propagation Delay	t_{PHL}, t_{PLH}	0.1		2.6	0.1		2.6	μs	50% input to 50% output
Pulse Width	PW	4			4			μs	Within PWD limit
Jitter, Low Speed	J_{LS}			2.5			2.5	μs	$ t_{PLH} - t_{PHL} $
SSAx ³ Minimum Input Skew ⁴	$t_{SSAX_SKEW}^3$	40			40			ns	

¹ Codirectional channel matching is the absolute value of the difference in propagation delays between any two channels with inputs on the same side of the isolation barrier.

² The \overline{MSS} signal is glitch filtered in both speed grades, whereas the other fast signals are not glitch filtered in the B grade. To guarantee that \overline{MSS} reaches the output ahead of another fast signal, set up \overline{MSS} prior to the competing signal by different times depending on speed grade.

³ SSAx = SSA1 or SSA2.

⁴ An internal asynchronous clock, not available to users, samples the low speed signals. If edge sequence in codirectional channels is critical to the end application, the leading pulse must be at least $1 t_{SSAX_SKEW}$ ahead of a later pulse to guarantee the correct order or simultaneous arrival at the output.

Table 7. For All Models^{1, 2, 3}

Parameter	Symbol	Min	Typ	Max	Unit	Test Conditions/Comments
SUPPLY CURRENT						
A Grade and B Grade	I _{DD1}		4.8	8.5	mA	C _L = 0 pF, DR _{FAST} = 1 MHz, DR _{SLOW} = 0 MHz
	I _{DD2}		5	9	mA	C _L = 0 pF, DR _{FAST} = 1 MHz, DR _{SLOW} = 0 MHz
B Grade	I _{DD1}		10	18	mA	C _L = 0 pF, DR _{FAST} = 17 MHz, DR _{SLOW} = 0 MHz
	I _{DD2}		10	14	mA	C _L = 0 pF, DR _{FAST} = 17 MHz, DR _{SLOW} = 0 MHz
DC SPECIFICATIONS						
MCLK, $\overline{\text{MSS}}$, MO, SO, SSA0, SSA1						
Input Threshold						
Logic High	V _{IH}	0.7 × V _{DDx}			V	
Logic Low	V _{IL}			0.3 × V _{DDx}	V	
Input Hysteresis	V _{IHYST}		500		mV	
Input Current per Channel	I _i	-1	+0.01	+1	μA	0 V ≤ V _{INPUT} ≤ V _{DDX}
SCLK, MI, SI, SS0, SS1, SS2, SS3						
Output Voltages						
Logic High	V _{OH}	V _{DDx} - 0.1	V _{DDx}		V	I _{OUTPUT} = -20 μA, V _{INPUT} = V _{IH}
		V _{DDx} - 0.4	V _{DDx} - 0.2		V	I _{OUTPUT} = -4 mA, V _{INPUT} = V _{IH}
Logic Low	V _{OL}		0.0	0.1	V	I _{OUTPUT} = 20 μA, V _{INPUT} = V _{IL}
			0.2	0.4	V	I _{OUTPUT} = 4 mA, V _{INPUT} = V _{IL}
V _{DD1} , V _{DD2} Undervoltage Lockout	UVLO		2.6		V	
Supply Current for All Low Speed Channels						
Quiescent Input	I _{DD1(Q)}		4.2		mA	
Quiescent Output	I _{DD2(Q)}		4.7		mA	
AC SPECIFICATIONS						
Output Rise/Fall Time	t _R /t _F		2.5		ns	10% to 90%
Common-Mode Transient Immunity ⁴	CM	25	35		kV/μs	V _{INPUT} = V _{DDx} , V _{CM} = 1000 V, transient magnitude = 800 V

¹ V_{DDx} = V_{DD1} or V_{DD2}.² V_{INPUT} is the input voltage of any of the MCLK, $\overline{\text{MSS}}$, MO, SO, SSA0, or SSA1 pins.³ I_{OUTPUT} is the output current of any of the SCLK, MI, SI, SS0, SS1, SS2, or SS3 pins.⁴ |CM| is the maximum common-mode voltage slew rate that can be sustained while maintaining output voltages within the V_{OH} and V_{OL} limits. The common-mode voltage slew rates apply to both rising and falling common-mode voltage edges.

ELECTRICAL CHARACTERISTICS—MIXED 3.3 V/5 V OPERATION

All typical specifications are at $T_A = 25^\circ\text{C}$ and $V_{DD1} = 3.3\text{ V}$, $V_{DD2} = 5\text{ V}$. Minimum and maximum specifications apply over the entire recommended operation range: $3.0\text{ V} \leq V_{DD1} \leq 3.6\text{ V}$, $4.5\text{ V} \leq V_{DD2} \leq 5.5\text{ V}$, and $-40^\circ\text{C} \leq T_A \leq +125^\circ\text{C}$, unless otherwise noted. Switching specifications are tested with $C_L = 15\text{ pF}$ and CMOS signal levels, unless otherwise noted.

Table 8. Switching Specifications

Parameter	Symbol	A Grade			B Grade			Unit	Test Conditions/Comments
		Min	Typ	Max	Min	Typ	Max		
MCLK, MO, SO									
SPI Clock Rate	SPI_{MCLK}			1			15.6	MHz	
Data Rate Fast (MO, SO)	DR_{FAST}			2			34	Mbps	Within PWD limit
Propagation Delay	t_{PHL}, t_{PLH}			28			17	ns	50% input to 50% output
Pulse Width	PW	100			12.5			ns	Within PWD limit
Pulse Width Distortion	PWD			2			2	ns	$ t_{PLH} - t_{PHL} $
Codirectional Channel Matching ¹	t_{PSKCD}			2			2	ns	
Jitter, High Speed	J_{HS}		1			1		ns	
MSS									
Jitter			1			1		ns	
Data Rate Fast	DR_{FAST}			2			34	Mbps	Within PWD limit
Propagation Delay	t_{PHL}, t_{PLH}			28		21	28	ns	50% input to 50% output
Pulse Width	PW	100			12.5			ns	Within PWD limit
Pulse Width Distortion	PWD			2			2	ns	$ t_{PLH} - t_{PHL} $
Setup Time ²	\overline{MSS}_{SETUP}	1.5			10			ns	
Jitter, High Speed	J_{HS}		1			1		ns	
SSA0, SSA1									
Data Rate Slow	DR_{SLOW}			250			250	kbps	Within PWD limit
Propagation Delay	t_{PHL}, t_{PLH}	0.1		2.6	0.1		2.6	μs	50% input to 50% output
Pulse Width	PW	4			4			μs	Within PWD limit
Jitter, Low Speed	J_{LS}			2.5			2.5	μs	$ t_{PLH} - t_{PHL} $
SSAx ³ Minimum Input Skew ⁴	$t_{SSAX_SKEW}^3$	40			40			ns	

¹ Codirectional channel matching is the absolute value of the difference in propagation delays between any two channels with inputs on the same side of the isolation barrier.

² The \overline{MSS} signal is glitch filtered in both speed grades, whereas the other fast signals are not glitch filtered in the B grade. To guarantee that \overline{MSS} reaches the output ahead of another fast signal, set up \overline{MSS} prior to the competing signal by different times depending on speed grade.

³ SSAx = SSA1 or SSA2.

⁴ An internal asynchronous clock, not available to users, samples the low speed signals. If edge sequence in codirectional channels is critical to the end application, the leading pulse must be at least $1 t_{SSAX_SKEW}$ ahead of a later pulse to guarantee the correct order or simultaneous arrival at the output.

Table 9. For All Models^{1, 2, 3}

Parameter	Symbol	Min	Typ	Max	Unit	Test Conditions/Comments
SUPPLY CURRENT						
A Grade and B Grade	I_{DD}		3.4	6.5	mA	$C_L = 0$ pF, $DR_{FAST} = 1$ MHz, $DR_{SLOW} = 0$ MHz
	I_{DD2}		6.5	13	mA	$C_L = 0$ pF, $DR_{FAST} = 1$ MHz, $DR_{SLOW} = 0$ MHz
B Grade	I_{DD}		11.7	15	mA	$C_L = 0$ pF, $DR_{FAST} = 17$ MHz, $DR_{SLOW} = 0$ MHz
	I_{DD2}		13.5	19	mA	$C_L = 0$ pF, $DR_{FAST} = 17$ MHz, $DR_{SLOW} = 0$ MHz
DC SPECIFICATIONS						
MCLK, \overline{MSS} , MO, SO, SSA0, SSA1						
Input Threshold						
Logic High	V_{IH}	$0.7 \times V_{DDx}$			V	
Logic Low	V_{IL}			$0.3 \times V_{DDx}$	V	
Input Hysteresis	V_{IHYST}		500		mV	
Input Current per Channel	I_i	-1	+0.01	+1	μ A	$0V \leq V_{INPUT} \leq V_{DDx}$
SCLK, MI, SI, SS0, SS1, SS2, SS3						
Output Voltages						
Logic High	V_{OH}	$V_{DDx} - 0.1$	V_{DDx}		V	$I_{OUTPUT} = -20$ μ A, $V_{INPUT} = V_{IH}$
		$V_{DDx} - 0.4$	$V_{DDx} - 0.2$		V	$I_{OUTPUT} = -4$ mA, $V_{INPUT} = V_{IH}$
Logic Low	V_{OL}		0.0	0.1	V	$I_{OUTPUT} = 20$ μ A, $V_{INPUT} = V_{IL}$
			0.2	0.4	V	$I_{OUTPUT} = 4$ mA, $V_{INPUT} = V_{IL}$
V_{DD1} , V_{DD2} Undervoltage Lockout	UVLO		2.6		V	
Supply Current for All Low Speed Channels						
Quiescent Input	$I_{DD1(Q)}$		2.9		mA	
Quiescent Output	$I_{DD2(Q)}$		6.1		mA	
AC SPECIFICATIONS						
Output Rise/Fall Time	t_R/t_F		2.5		ns	10% to 90%
Common-Mode Transient Immunity ⁴	$ CM $	25	35		kV/ μ s	$V_{INPUT} = V_{DDx}$, $V_{CM} = 1000$ V, transient magnitude = 800 V

¹ $V_{DDx} = V_{DD1}$ or V_{DD2} .² V_{INPUT} is the input voltage of any of the MCLK, \overline{MSS} , MO, SO, SSA0, or SSA1 pins.³ I_{OUTPUT} is the output current of any of the SCLK, MI, SI, SS0, SS1, SS2, or SS3 pins.⁴ $|CM|$ is the maximum common-mode voltage slew rate that can be sustained whereas maintaining output voltages within the V_{OH} and V_{OL} limits. The common-mode voltage slew rates apply to both rising and falling common-mode voltage edges.

PACKAGE CHARACTERISTICS

Table 10.

Parameter	Symbol	Min	Typ	Max	Unit	Test Conditions/Comments
Resistance (Input to Output) ¹	R_{I-O}		10^{12}		Ω	
Capacitance (Input to Output) ¹	C_{I-O}		1.0		pF	$f = 1$ MHz
Input Capacitance ²	C_I		4.0		pF	
IC Junction to Case Thermal Resistance	θ_{JC}		68.5		$^{\circ}$ C/W	4-layer JEDEC test board, JESD 51-7 specification

¹ The device is considered a 2-terminal device: Pin 1 through Pin 10 are shorted together, and Pin 11 through Pin 20 are shorted together.² Input capacitance is from any input data pin to ground.

REGULATORY INFORMATION

The ADuM3154 is approved by the organizations listed in Table 11. See Table 16 and the Insulation Lifetime section for recommended maximum working voltages for specific cross isolation waveforms and insulation levels.

Table 11.

UL	CSA	VDE
Recognized under 1577 Component Recognition Program ¹ 3750 V rms Single Protection File E214100	Approved under CSA Component Acceptance Notice #5A Basic insulation per CSA 60950-1-07+A1+A2 and IEC 60950-1 2 nd Ed.+A1+A2, 510 V rms (721 V peak) maximum working voltage ³ File 205078	Certified according to DIN V VDE V 0884-10 (VDE V 0884-10):2006-12 ² Reinforced insulation, 565 V peak File 2471900-4880-0001

¹ In accordance with UL 1577, each ADuM3154 is proof tested by applying an insulation test voltage ≥ 4500 V rms for 1 second (current leakage detection limit = 10 μ A).

² In accordance with DIN V VDE V 0884-10, each ADuM3154 is proof tested by applying an insulation test voltage ≥ 525 V peak for 1 second (partial discharge detection limit = 5 pC). The asterisk (*) marked on the component designates DIN V VDE V 0884-10 approval.

³ See Table 16 for recommended maximum working voltages under various operating conditions.

INSULATION AND SAFETY RELATED SPECIFICATIONS**Table 12.**

Parameter	Symbol	Value	Unit	Test Conditions/Comments
Rated Dielectric Insulation Voltage		3750	V rms	1 minute duration
Minimum External Air Gap (Clearance)	L(I01)	5.1	mm min	Measured from input terminals to output terminals, shortest distance through air
Minimum External Tracking (Creepage)	L(I02)	5.1	mm min	Measured from input terminals to output terminals, shortest distance path along body
Minimum Internal Gap (Internal Clearance)		0.017	mm min	Distance through insulation
Tracking Resistance (Comparative Tracking Index)	CTI	>400	V	DIN IEC 112/VDE 0303 Part 1
Material Group		II		Material group (DIN VDE 0110, 1/89, Table 1)

DIN V VDE V 0884-10 (VDE V 0884-10):2006-12 INSULATION CHARACTERISTICS

This isolator is suitable for reinforced electrical isolation only within the safety limit data. Maintenance of the safety data is ensured by protective circuits. The asterisk (*) marked on packages denotes DIN V VDE V 0884-10 approval.

Table 13.

Description	Test Conditions/Comments	Symbol	Characteristic	Unit
Installation Classification per DIN VDE 0110 For Rated Mains Voltage ≤ 150 V rms For Rated Mains Voltage ≤ 300 V rms For Rated Mains Voltage ≤ 400 V rms Climatic Classification			I to IV I to III I to II 40/105/21	
Pollution Degree per DIN VDE 0110, Table 1			2	
Maximum Working Insulation Voltage		V _{IORM}	565	V peak
Input-to-Output Test Voltage, Method b1	V _{IORM} × 1.875 = V _{pd(m)} , 100% production test, t _{ini} = t _m = 1 sec, partial discharge < 5 pC	V _{pd(m)}	1059	V peak
Input-to-Output Test Voltage, Method a After Environmental Tests Subgroup 1	V _{IORM} × 1.5 = V _{pd(m)} , t _{ini} = 60 sec, t _m = 10 sec, partial discharge < 5 pC	V _{pd(m)}	848	V peak
After Input and/or Safety Test Subgroup 2 and Subgroup 3	V _{IORM} × 1.2 = V _{pd(m)} , t _{ini} = 60 sec, t _m = 10 sec, partial discharge < 5 pC	V _{pd(m)}	678	V peak
Highest Allowable Overvoltage		V _{IOTM}	5000	V peak
Surge Isolation Voltage		V _{IOSM}	6250	V peak
Safety Limiting Values	V _{IOSM(T_{TEST})} = 10 kV, 1.2 μs rise time, 50 μs, 50% fall time Maximum value allowed in the event of a failure (see Figure 2)			
Case Temperature		T _S	150	°C
Safety Total Dissipated Power		I _{S1}	1.4	W
Insulation Resistance at T _S	V _{IO} = 500 V	R _S	>10 ⁹	Ω

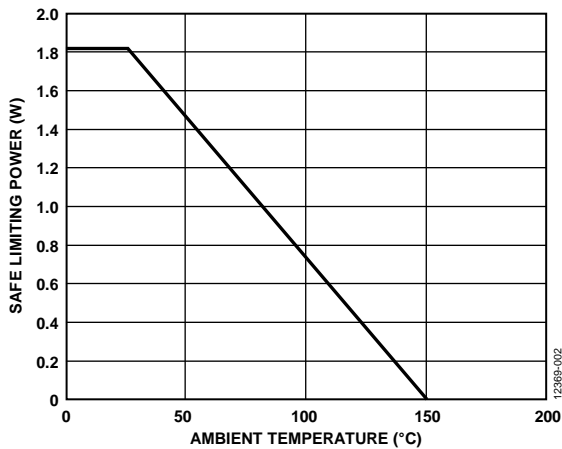

Figure 2. Thermal Derating Curve, Dependence of Safety Limiting Values with Case Temperature per DIN V VDE V 0884-10

RECOMMENDED OPERATING CONDITIONS

Table 14.

Parameter	Symbol	Min	Max	Unit
Operating Temperature Range	T _A	-40	+125	°C
Supply Voltage Range ¹	V _{DD1} , V _{DD2}	3.0	5.5	V
Input Signal Rise and Fall Times			1.0	ms

¹ See the DC Correctness and Magnetic Field Immunity section for information on the immunity to the external magnetic fields.

ABSOLUTE MAXIMUM RATINGS

$T_A = 25^\circ\text{C}$, unless otherwise noted

Table 15.

Parameter	Rating
Storage Temperature (T_{ST}) Range	-65°C to $+150^\circ\text{C}$
Ambient Operating Temperature (T_A) Range	-40°C to $+125^\circ\text{C}$
Supply Voltages (V_{DD1} , V_{DD2})	-0.5 V to $+7.0\text{ V}$
Input Voltages (MCLK, MSS, MO, SO, SSA0, SSA1)	-0.5 V to $V_{DDx} + 0.5\text{ V}$
Output Voltages (SCLK, MI, SI, SS0, SS1, SS2, SS3)	-0.5 V to $V_{DDx} + 0.5\text{ V}$
Average Output Current per Pin ¹	-10 mA to $+10\text{ mA}$
Common-Mode Transients ²	$-100\text{ kV}/\mu\text{s}$ to $+100\text{ kV}/\mu\text{s}$

¹ See Figure 2 for maximum safety rated current values across temperature.

² Refers to common-mode transients across the insulation barrier. Common-mode transients exceeding the absolute maximum ratings may cause latch-up or permanent damage.

Stresses at or above those listed under Absolute Maximum Ratings may cause permanent damage to the product. This is a stress rating only; functional operation of the product at these or any other conditions above those indicated in the operational section of this specification is not implied. Operation beyond the maximum operating conditions for extended periods may affect product reliability.

Table 16. Maximum Continuous Working Voltage¹

Parameter	Max	Unit	Constraint
AC 60 Hz RMS Voltage	400	V rms	20-year lifetime at 0.1% failure rate, zero average voltage
DC Voltage	722	V peak	Limited by the creepage of the package, Pollution Degree 2, Material Group II ^{2, 3}

¹ See the Insulation Lifetime section for details.

² Other pollution degree and material group requirements yield a different limit.

³ Some system level standards allow components to use the printed wiring board (PWB) creepage values. The supported dc voltage may be higher for those standards.

ESD CAUTION



ESD (electrostatic discharge) sensitive device. Charged devices and circuit boards can discharge without detection. Although this product features patented or proprietary protection circuitry, damage may occur on devices subjected to high energy ESD. Therefore, proper ESD precautions should be taken to avoid performance degradation or loss of functionality.

PIN CONFIGURATION AND FUNCTION DESCRIPTIONS

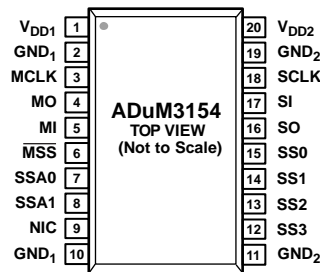

NOTES
 1. NIC = NOT INTERNALLY CONNECTED. THIS PIN IS NOT INTERNALLY CONNECTED AND SERVES NO FUNCTION IN THE ADuM3154.

12389-003

Figure 3. Pin Configuration

Table 17. Pin Function Descriptions

Pin No.	Mnemonic	Direction	Description
1	V _{DD1}	Power	Input Power Supply for Side 1. A bypass capacitor from V _{DD1} to GND ₁ to local ground is required.
2, 10	GND ₁	Return	Ground 1. Ground reference for Isolator Side 1.
3	MCLK	Input	SPI Clock from the Master Controller.
4	MO	Input	SPI Data from the Master to the Slave MO/SI Line.
5	MI	Output	SPI Data from the Slave to the Master MI/SO Line.
6	MSS	Input	Slave Select from the Master. This signal uses an active low logic. The slave select pin can require as much as a 10 ns setup time from the next clock or data edge depending on the speed grade.
7	SSA0	Input	Multiplexer Selection Input, Low Order Bit.
8	SSA1	Input	Multiplexer Selection Input, High Order Bit.
9	NIC		Not Internally Connected. This pin is not internally connected and serves no function in the ADuM3154 .
11, 19	GND ₂	Return	Ground 2. Ground reference for Isolator Side 2.
12	SS3	Output	Routed Slave Select Signal. High-Z when SS2 is not selected.
13	SS2	Output	Routed Slave Select Signal. High-Z when SS1 is not selected.
14	SS1	Output	Routed Slave Select Signal. High-Z when SS0 is not selected.
15	SS0	Output	Routed Slave Select Signal. High-Z when SS0 is not selected.
16	SO	Input	SPI Data from the Slave to the Master MI/SO Line.
17	SI	Output	SPI Data from the Master to the Slave MO/SI Line.
18	SCLK	Output	SPI Clock from the Master Controller.
20	V _{DD2}	Power	Input Power Supply for Side 2. A bypass capacitor from V _{DD2} to GND ₂ to local ground is required.

Table 18. Multiplexer Select Truth Table¹

Master Mux Inputs			Slave Mux Outputs			
MSS	SSA0	SSA1	SS0	SS1	SS2	SS3
1	0	0	1	Z	Z	Z
0	0	0	0	Z	Z	Z
1	1	0	Z	1	Z	Z
0	1	0	Z	0	Z	Z
1	0	1	Z	Z	1	Z
0	0	1	Z	Z	0	Z
1	1	1	Z	Z	Z	1
0	1	1	Z	Z	Z	0

¹ Z = high impedance.

Table 19. Power Off Default State Truth Table (Positive Logic)^{1, 2}

Master Side				Slave Side			
Power State	Output	Inputs		Power State	Input	Outputs	
V _{DD1}	MI	MCLK	MO	V _{DD2}	SO	SCLK	SI
Unpowered ³	Z	X	X	Powered	X	Z	Z
Powered	Z	X	X	Unpowered ³	X	Z	Z
Powered	1	1	1	Powered	1	1	1
Powered	0	0	0	Powered	0	0	0

¹ Z = high impedance.

² X = irrelevant.

³ Outputs on an unpowered side are high impedance within one diode drop of ground.

TYPICAL PERFORMANCE CHARACTERISTICS

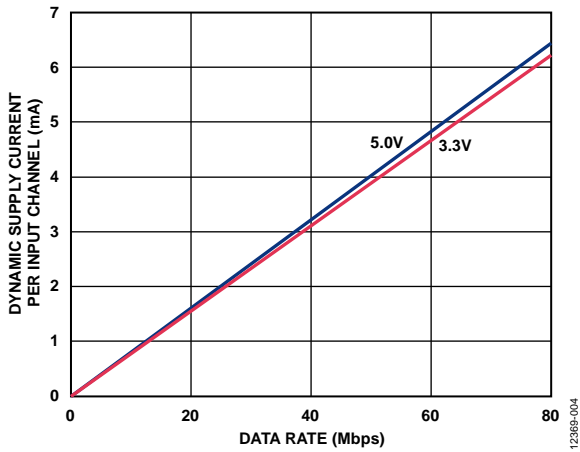

Figure 4. Typical Dynamic Supply Current per Input Channel vs. Data Rate for 5.0 V and 3.3 V Operation

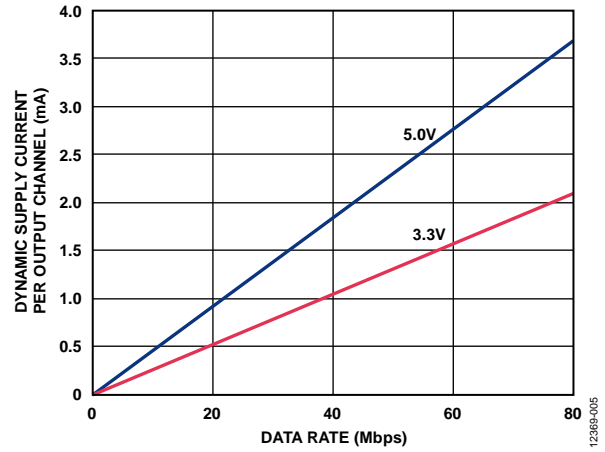

Figure 7. Typical Dynamic Supply Current per Output Channel vs. Data Rate for 5.0 V and 3.3 V Operation

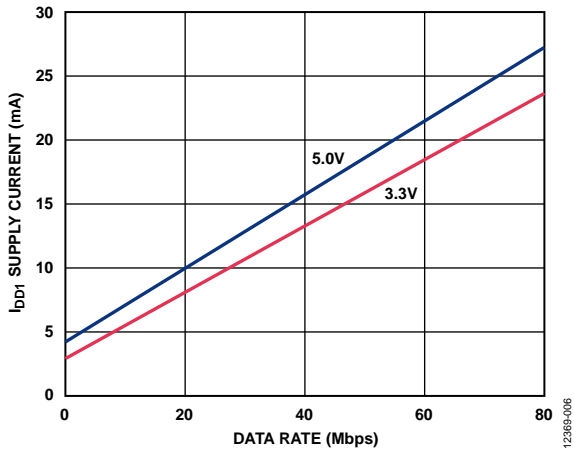

Figure 5. Typical I_{DD1} Supply Current vs. Data Rate for 5.0 V and 3.3 V Operation

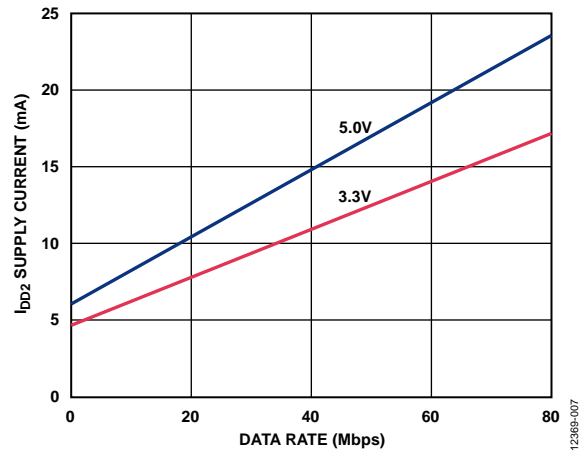

Figure 8. Typical I_{DD2} Supply Current vs. Data Rate for 5.0 V and 3.3 V Operation

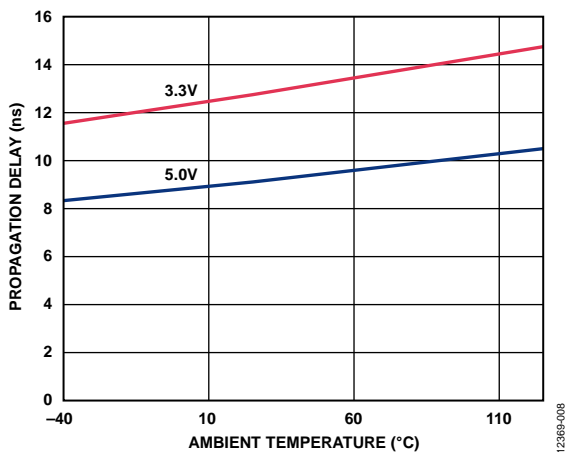

Figure 6. Typical Propagation Delay vs. Ambient Temperature for High Speed Channels Without Glitch Filter (See the High Speed Channels Section)

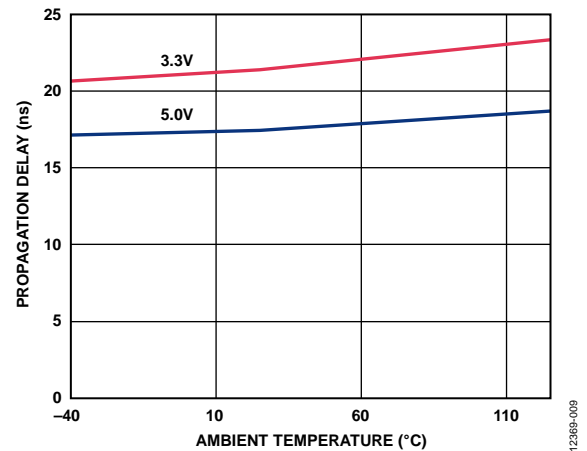

Figure 9. Typical Propagation Delay vs. Ambient Temperature for High Speed Channels with Glitch Filter (See the High Speed Channels Section)

APPLICATIONS INFORMATION

INTRODUCTION

The ADuM3154 was created to optimize isolation of the SPI for speed and provide additional low speed channels for control and status monitoring functions. The isolator is based on differential signaling *i*Coupler technology for enhanced speed and noise immunity.

High Speed Channels

The ADuM3154 has four high speed channels. The first three channels, CLK, MI/SO, and MO/SI (the slash indicates the connection of the particular input and output channel across the isolator), are optimized for either low propagation delay in the B grade, or high noise immunity in the A grade. The difference between the grades is the addition of a glitch filter to these three channels in the A grade version, which increases the propagation delay. The B grade version, with a maximum propagation delay of 14 ns, supports a maximum clock rate of 17 MHz in standard 4-wire SPI. However, because the glitch filter is not present in the B grade version, ensure that spurious glitches of less than 10 ns are not present.

Glitches of less than 10 ns in the B grade devices can cause the second edge of the glitch to be missed. This pulse condition is then seen as a spurious data transition on the output that is corrected by a refresh or the next valid data edge. It is recommended to use the A grade devices in noisy environments.

The relationship between the SPI signal paths and the pin mnemonics of the ADuM3154 and data directions is detailed in Table 20.

Table 20. Pin Mnemonics Correspondence to SPI Signal Path Names

SPI Signal Path	Master Side 1	Data Direction	Slave Side 2
CLK	MCLK	→	SCLK
MO/SI	MO	→	SI
MI/SO	MI	←	SO
SS	MSS	→	SSx

The datapaths are SPI mode agnostic. The CLK and MOSI SPI datapaths are optimized for propagation delay and channel to channel matching. The MISO SPI datapath is optimized for propagation delay. The device does not synchronize to the clock channel; therefore, there are no constraints on the clock polarity or the timing with respect to the data line. To allow compatibility with nonstandard SPI interfaces, the MI pin is always active, and does not tristate when the slave select is not asserted. This precludes tying several MI lines together without adding a tristate buffer or multiplexor.

The \overline{SS} (slave select bar) is typically an active low signal. It can have many different functions in SPI and SPI like busses. Many of these functions are edge triggered, so the \overline{SS} path contains a glitch filter in both the A grade and the B grade. The glitch filter prevents short pulses from propagating to the output or causing other errors in operation. The \overline{MSS} signal requires a 10 ns setup time in the B grade devices prior to the first active clock edge to allow the added propagation time of the glitch filter.

Slave Select Multiplexer

The ADuM3154 can control up to four independent slave devices. Figure 10 shows how this can be done using general-purpose isolators. An isolation channel is required for each slave select; therefore, seven high speed channels are required to transfer bidirectional data to four slaves.

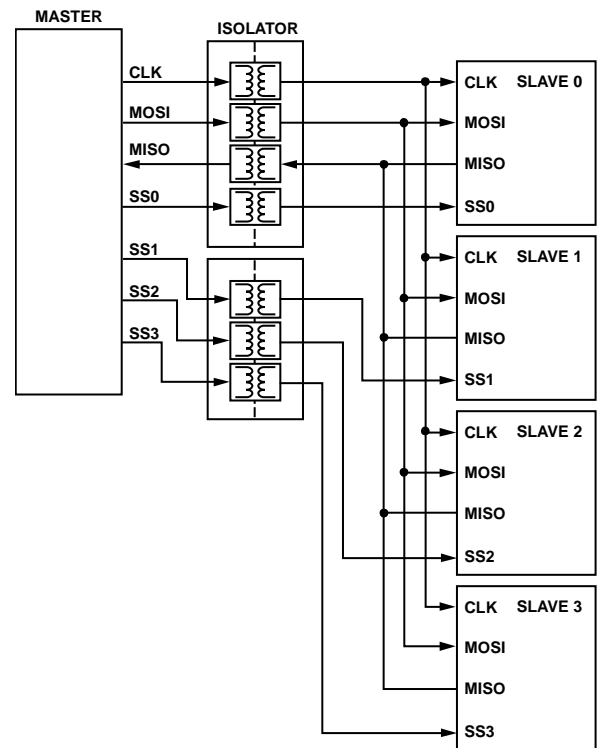

Figure 10. Multiple Slave Control with Standard Isolators

12389-010

Figure 11 shows how the ADuM3154 can control up to four slaves by routing the \overline{MSS} input to one of four outputs on the slave side of the isolator, which eliminates three isolation channels compared to the standard solution.

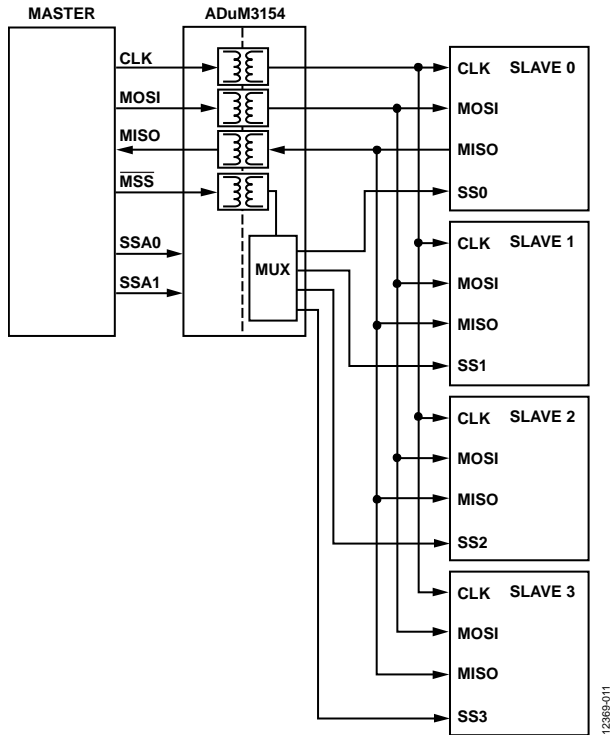

Figure 11. Multiple Slave Control

The multiplexer select lines are low speed channels implemented as part of the dc correctness scheme in the ADuM3154. The dc value of all high and low speed inputs on a given side of the device are sampled simultaneously, packetized, and shifted across an isolation coil. The high speed channels are compared for dc accuracy, and the low speed mux select lines, SSA0 and SSA1, are transferred to the mux control block. The dc correctness data for the high speed channels is handled internally with no visibility off chip.

This data is regulated by a free running internal clock. Because data is sampled at discrete times based on this clock, the propagation delay for mux select lines is between 100 ns and 2.6 μ s depending on where the input data edge changes with respect to the internal sample clock. After an address propagation delay time of up to 2.6 μ s, the multiplexer routes the \overline{MSS} signals to the desired output. The outputs that are not selected are set to high-Z, and the application pulls them to the desired idle state.

Figure 12 illustrates the behavior of the SSA0 and SSA1 channels. This diagram assumes that \overline{MSS} is low and that SS0, SS1, SS2, and SS3 are pulled up.

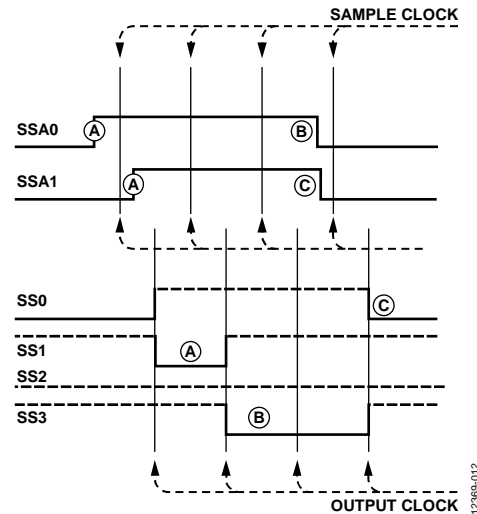

Figure 12. Mux Select Timing

The following details the mux select timing shown in Figure 12:

- Point A: The mux select lines must be switched simultaneously to within the t_{SSAx_SKEW} time. Failure to do this may allow sampling the inputs between the edges and selecting an incorrect mux output. Point A on SS1 is a metastable state on the output mux resulting from wide spacing between SSA0 and SSA1.
- Point B: For mux select lines to be processed predictably, a state of SSA0 and SSA1 must be stable for longer than 4 μ s before switching the mux to another output. This guarantees that at least two samples are taken of the inputs before the mux output is changed.
- Point C: This point in Figure 12 shows a clean transfer between SS3 being active and SS0 being active. The mux was designed to eliminate any short duration metastable states between any two selected outputs.

PRINTED CIRCUIT BOARD (PCB) LAYOUT

The ADuM3154 digital isolator requires no external interface circuitry for the logic interfaces. Power supply bypassing is strongly recommended at both input and output supply pins, V_{DD1} and V_{DD2} (see Figure 13). The capacitor value must be between 0.01 μF and 0.1 μF . The total lead length between both ends of the capacitor and the input power supply pin must not exceed 20 mm.

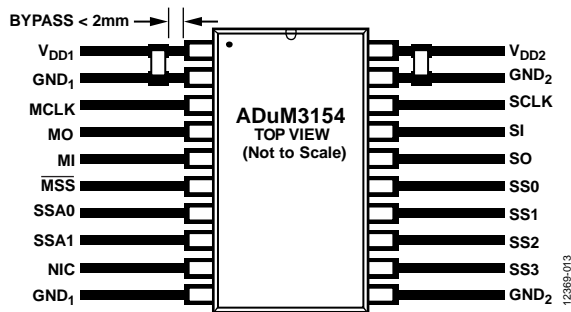

Figure 13. Recommended PCB Layout

In applications involving high common-mode transients, it is important to minimize board coupling across the isolation barrier. Furthermore, design the board layout so that any coupling that does occur affects all pins equally on a given component side. Failure to ensure this can cause voltage differentials between pins exceeding the absolute maximum ratings of the device, thereby leading to latch-up or permanent damage.

PROPAGATION DELAY RELATED PARAMETERS

Propagation delay is a parameter that describes the time it takes a logic signal to propagate through a component. The input to output propagation delay time for a high to low transition may differ from the propagation delay time of a low to high transition.

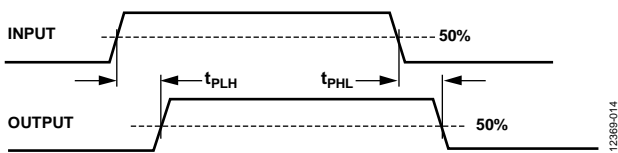

Figure 14. Propagation Delay Parameters

Pulse width distortion is the maximum difference between these two propagation delay values and an indication of how accurately the timing of the input signal is preserved.

Channel to channel matching refers to the maximum amount the propagation delay differs between channels within a single ADuM3154 component.

DC CORRECTNESS AND MAGNETIC FIELD IMMUNITY

Positive and negative logic transitions at the isolator input cause narrow (~1 ns) pulses to be sent via the transformer to the decoder. The decoder is bistable and is, therefore, either set or reset by the pulses indicating input logic transitions. In the absence of logic transitions at the input for more than ~1.2 μs , a periodic set of refresh pulses indicative of the correct input state are sent via the low speed channel to ensure dc correctness at the output.

If the low speed decoder receives no pulses for more than about 5 μs , the input side is assumed to be unpowered or nonfunctional, in which case, the isolator output is forced to a high-Z state by the watchdog timer circuit.

The limitation on the magnetic field immunity of the device is set by the condition in which induced voltage in the transformer receiving coil is sufficiently large to either falsely set or reset the decoder. The following analysis defines such conditions. The ADuM3154 is examined in a 3 V operating condition because it represents the most susceptible mode of operation for this product.

The pulses at the transformer output have an amplitude greater than 1.5 V. The decoder has a sensing threshold of about 1.0 V; thereby establishing a 0.5 V margin in which induced voltages can be tolerated. The voltage induced across the receiving coil is given by

$$V = (-d\beta/dt)\sum\pi r_n^2; n = 1, 2, \dots, N$$

where:

β is the magnetic flux density.

r_n is the radius of the n^{th} turn in the receiving coil.

N is the number of turns in the receiving coil.

Given the geometry of the receiving coil in the ADuM3154 and an imposed requirement that the induced voltage be, at most, 50% of the 0.5 V margin at the decoder, a maximum allowable magnetic field is calculated, as shown in Figure 15.

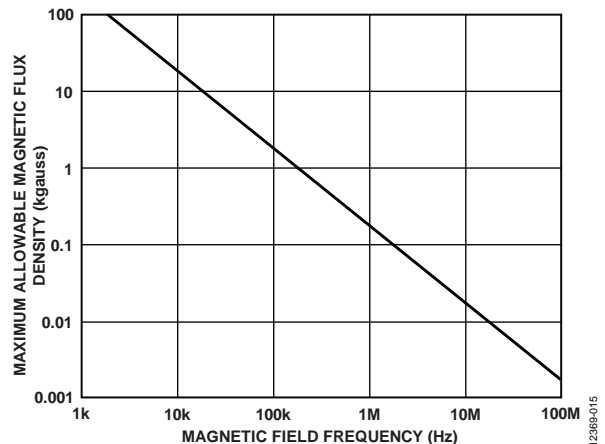

Figure 15. Maximum Allowable External Magnetic Flux Density

For example, at a magnetic field frequency of 1 MHz, the maximum allowable magnetic field of 0.5 kgauss induces a voltage of 0.25 V at the receiving coil. This is about 50% of the sensing threshold and does not cause a faulty output transition. If such an event occurs, with the worst-case polarity, during a transmitted pulse, it reduces the received pulse from >1.0 V to 0.75 V, which is still well above the 0.5 V sensing threshold of the decoder.

The preceding magnetic flux density values correspond to specific current magnitudes at given distances away from the ADuM3154 transformers. Figure 16 expresses these allowable current magnitudes as a function of frequency for selected distances. The ADuM3154 is insensitive to external fields. Only extremely large, high frequency currents very close to the component are potentially a concern. For the 1 MHz example noted, a user would have to place a 1.2 kA current 5 mm away from the ADuM3154 to affect component operation.

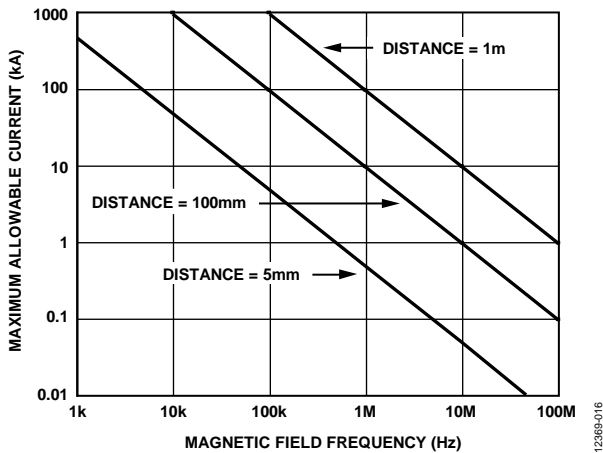

Figure 16. Maximum Allowable Current for Various Current to ADuM3154 Spacings

At combinations of a strong magnetic field and high frequency, any loops formed by the PCB traces may induce sufficiently large error voltages to trigger the thresholds of succeeding circuitry. Take care to avoid PCB structures that form loops.

POWER CONSUMPTION

The supply current at a given channel of the ADuM3154 isolator is a function of the supply voltage, the data rate of the channel, the output load of the channel, and whether it is a high or low speed channel.

The low speed channels draw a constant quiescent current caused by the internal ping-pong datapath. The operating frequency is low enough that the capacitive losses caused by the recommended capacitive load are negligible compared to the quiescent current. The explicit calculation for the data rate is eliminated for simplicity, and the quiescent current for each side of the isolator due to the low speed channels can be found in Table 3, Table 5, Table 7, and Table 9 for the particular operating voltages.

These quiescent currents add to the high speed current as is shown in the following equations for the total current for each side of the isolator. Dynamic currents are taken from Table 3 and Table 5 for the respective voltages.

For Side 1, the supply current is given by

$$I_{DD1} = I_{DD1(D)} \times (f_{MCLK} + f_{MO} + f_{MSS}) + f_{MI} \times (I_{DDO(D)} + ((0.5 \times 10^{-3}) \times C_{L(MI)} \times V_{DD1})) + I_{DD1(Q)}$$

For Side 2, the supply current is given by

$$I_{DD2} = I_{DD1(D)} \times f_{SO} + f_{SCLK} \times (I_{DDO(D)} + ((0.5 \times 10^{-3}) \times C_{L(SCLK)} \times V_{DD2})) + f_{SI} \times (I_{DDO(D)} + ((0.5 \times 10^{-3}) \times C_{L(SI)} \times V_{DD2})) + f_{SSx} \times (I_{DDO(D)} + ((0.5 \times 10^{-3}) \times C_{L(SSx)} \times V_{DD2})) + I_{DD2(Q)}$$

where:

$I_{DD1(D)}$, $I_{DDO(D)}$ are the input and output dynamic supply currents per channel (mA/Mbps).

f_x is the logic signal data rate for the specified channel (Mbps).

$C_{L(x)}$ is the load capacitance of the specified output (pF).

V_{DDx} is the supply voltage of the side being evaluated (V).

$I_{DD1(Q)}$, $I_{DD2(Q)}$ are the specified Side 1 and Side 2 quiescent supply currents (mA).

Figure 4 and Figure 7 show the supply current per channel as a function of data rate for an input and unloaded output. Figure 5 and Figure 8 show the total I_{DD1} and I_{DD2} supply currents as a function of data rate for ADuM3154 channel configurations with all high speed channels running at the same speed and the low speed channels at idle.

INSULATION LIFETIME

All insulation structures eventually break down when subjected to voltage stress over a sufficiently long period. The rate of insulation degradation is dependent on the characteristics of the voltage waveform applied across the insulation, as well as the materials and material interfaces.

Two types of insulation degradation are of primary interest: breakdown along surfaces exposed to the air and insulation wear out. Surface breakdown is the phenomenon of surface tracking and the primary determinant of surface creepage requirements in system level standards. Insulation wear out is the phenomenon where charge injection or displacement currents inside the insulation material cause long-term insulation degradation.

Surface Tracking

Surface tracking is addressed in electrical safety standards by setting a minimum surface creepage based on the working voltage, the environmental conditions, and the properties of the insulation material. Safety agencies perform characterization testing on the surface insulation of components that allow the components to be categorized in different material groups. Lower material group ratings are more resistant to surface tracking and, therefore, can provide adequate lifetime with

smaller creepage. The minimum creepage for a given working voltage and material group is in each system level standard and is based on the total rms voltage across the isolation, pollution degree, and material group. The material group and creepage for the ADuM3154 isolator are detailed in Table 12.

Insulation Wear Out

The lifetime of insulation caused by wear out is determined by its thickness, the material properties, and the voltage stress applied. It is important to verify that the product lifetime is adequate at the application working voltage. The working voltage supported by an isolator for wear out may not be the same as the working voltage supported for tracking. It is the working voltage applicable to tracking that is specified in most standards.

Testing and modeling have shown that the primary driver of long-term degradation is displacement current in the polyimide insulation causing incremental damage. The stress on the insulation can be broken down into two broad categories, such as dc stress, which causes very little wear out because there is no displacement current, and an ac component time varying voltage stress, which causes wear out.

The ratings in certification documents are usually based on 60 Hz sinusoidal stress, because this reflects isolation from line voltage. However, many practical applications have combinations of 60 Hz ac and dc across the barrier, as shown in Equation 1. Because only the ac portion of the stress causes wear out, the equation can be rearranged to solve for the ac rms voltage, as shown in Equation 2. For insulation wear out with the polyimide materials used in this product, the ac rms voltage determines the product lifetime.

$$V_{RMS} = \sqrt{V_{AC\ RMS}^2 + V_{DC}^2} \tag{1}$$

or

$$V_{AC\ RMS} = \sqrt{V_{RMS}^2 - V_{DC}^2} \tag{2}$$

where:

V_{RMS} is the total rms working voltage.

$V_{AC\ RMS}$ is the time varying portion of the working voltage.

V_{DC} is the dc offset of the working voltage.

Calculation and Use of Parameters Example

The following is an example that frequently arises in power conversion applications. Assume that the line voltage on one side of the isolation is 240 V_{AC RMS}, and a 400 V_{DC} bus voltage is present on the other side of the isolation barrier. The isolator

material is polyimide. To establish the critical voltages in determining the creepage clearance and lifetime of a device, see Figure 17 and the following equations.

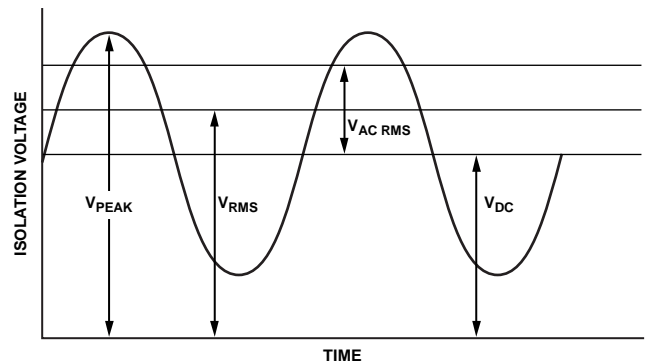

Figure 17. Critical Voltage Example

The working voltage across the barrier from Equation 1 is

$$V_{RMS} = \sqrt{V_{AC\ RMS}^2 + V_{DC}^2}$$

$$V_{RMS} = \sqrt{240^2 + 400^2}$$

$$V_{RMS} = 466\text{ V}$$

This is the working voltage used together with the material group and pollution degree when looking up the creepage required by a system standard.

To determine if the lifetime is adequate, obtain the time varying portion of the working voltage. The ac rms voltage can be obtained from Equation 2.

$$V_{AC\ RMS} = \sqrt{V_{RMS}^2 - V_{DC}^2}$$

$$V_{AC\ RMS} = \sqrt{466^2 - 400^2}$$

$$V_{AC\ RMS} = 240\text{ V}_{RMS}$$

In this case, the V_{AC RMS} is simply the line voltage of 240 V_{RMS}. This calculation is more relevant when the waveform is not sinusoidal. The value is compared to the limits for the working voltage listed in Table 16 or the expected lifetime, under a 60 Hz sine wave, and it is well within the limit for a 50-year service life.

Note that the dc working voltage limit in Table 16 is set by the creepage of the package as specified in IEC 60664-1. This value may differ for specific system level standards.

OUTLINE DIMENSIONS

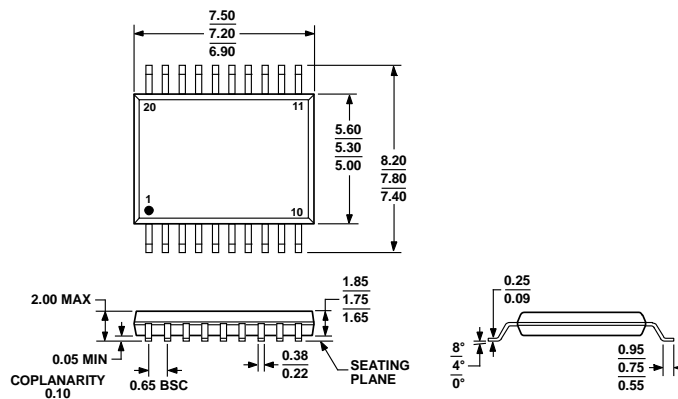

COMPLIANT TO JEDEC STANDARDS MO-150-AE

Figure 18. 20-Lead Shrink Small Outline Package [SSOP]
(RS-20)

Dimensions shown in millimeters

ORDERING GUIDE

Model ¹	No. of Inputs, V _{DD1} Side	No. of Inputs, V _{DD2} Side	Maximum Data Rate (MHz)	Maximum Propagation Delay, 5 V (ns)	Isolation Rating (V rms)	Temperature Range	Package Description	Package Option
ADuM3154ARSZ	5	1	1	25	3750	-40°C to +125°C	20-Lead SSOP	RS-20
ADuM3154ARSZ-RL7	5	1	1	25	3750	-40°C to +125°C	20-Lead SSOP, 7" Tape and Reel	RS-20
ADuM3154BRSZ	5	1	17	14	3750	-40°C to +125°C	20-Lead SSOP	RS-20
ADuM3154BRSZ-RL7	5	1	17	14	3750	-40°C to +125°C	20-Lead SSOP, 7" Tape and Reel	RS-20
EVAL-ADuM3154Z							Evaluation Board	

¹ Z = RoHS Compliant Part.

Компания «Океан Электроники» предлагает заключение долгосрочных отношений при поставках импортных электронных компонентов на взаимовыгодных условиях!

Наши преимущества:

- Поставка оригинальных импортных электронных компонентов напрямую с производств Америки, Европы и Азии, а так же с крупнейших складов мира;
- Широкая линейка поставок активных и пассивных импортных электронных компонентов (более 30 млн. наименований);
- Поставка сложных, дефицитных, либо снятых с производства позиций;
- Оперативные сроки поставки под заказ (от 5 рабочих дней);
- Экспресс доставка в любую точку России;
- Помощь Конструкторского Отдела и консультации квалифицированных инженеров;
- Техническая поддержка проекта, помощь в подборе аналогов, поставка прототипов;
- Поставка электронных компонентов под контролем ВП;
- Система менеджмента качества сертифицирована по Международному стандарту ISO 9001;
- При необходимости вся продукция военного и аэрокосмического назначения проходит испытания и сертификацию в лаборатории (по согласованию с заказчиком);
- Поставка специализированных компонентов военного и аэрокосмического уровня качества (Xilinx, Altera, Analog Devices, Intersil, Interpoint, Microsemi, Actel, Aeroflex, Peregrine, VPT, Syfer, Eurofarad, Texas Instruments, MS Kennedy, Miteq, Cobham, E2V, MA-COM, Hittite, Mini-Circuits, General Dynamics и др.);

Компания «Океан Электроники» является официальным дистрибьютором и эксклюзивным представителем в России одного из крупнейших производителей разъемов военного и аэрокосмического назначения «JONHON», а так же официальным дистрибьютором и эксклюзивным представителем в России производителя высокотехнологичных и надежных решений для передачи СВЧ сигналов «FORSTAR».



JONHON

«JONHON» (основан в 1970 г.)

Разъемы специального, военного и аэрокосмического назначения:

(Применяются в военной, авиационной, аэрокосмической, морской, железнодорожной, горно- и нефтедобывающей отраслях промышленности)

«FORSTAR» (основан в 1998 г.)

ВЧ соединители, коаксиальные кабели,
кабельные сборки и микроволновые компоненты:

(Применяются в телекоммуникациях гражданского и специального назначения, в средствах связи, РЛС, а так же военной, авиационной и аэрокосмической отраслях промышленности).



Телефон: 8 (812) 309-75-97 (многоканальный)

Факс: 8 (812) 320-03-32

Электронная почта: ocean@oceanchips.ru

Web: <http://oceanchips.ru/>

Адрес: 198099, г. Санкт-Петербург, ул. Калинина, д. 2, корп. 4, лит. А