



LPC546xx

32-bit ARM Cortex-M4 microcontroller; up to 512 KB flash and 200 kB SRAM; High-speed USB device/host + PHY; Full-speed USB device/host; Ethernet AVB; LCD; EMC; SPIFI; CAN FD, SDIO; SHA; 12-bit 5 Msamples/s ADC; DMIC subsystem

Rev. 2.7 — 24 February 2020

Product data sheet

1. General description

The LPC546xx is a family of ARM Cortex-M4 based microcontrollers for embedded applications featuring a rich peripheral set with very low power consumption and enhanced debug features.

The ARM Cortex-M4 is a 32-bit core that offers system enhancements such as low power consumption, enhanced debug features, and a high level of support block integration. The ARM Cortex-M4 CPU incorporates a 3-stage pipeline, uses a Harvard architecture with separate local instruction and data buses as well as a third bus for peripherals, and includes an internal prefetch unit that supports speculative branching. The ARM Cortex-M4 supports single-cycle digital signal processing and SIMD instructions. A hardware floating-point processor is integrated into the core.

The LPC546xx family includes up to 512 KB of flash, 200 KB of on-chip SRAM, up to 16 kB of EEPROM memory, a quad SPI Flash Interface (SPIFI) for expanding program memory, one high-speed and one full-speed USB host and device controller, Ethernet AVB, LCD controller, Smart Card Interfaces, SD/MMC, CAN FD, an External Memory Controller (EMC), a DMIC subsystem with PDM microphone interface and I²S, five general-purpose timers, SCTimer/PWM, RTC/alarm timer, Multi-Rate Timer (MRT), a Windowed Watchdog Timer (WWDT), ten flexible serial communication peripherals (USART, SPI, I²S, I²C interface), Secure Hash Algorithm (SHA), 12-bit 5.0 Msamples/sec ADC, and a temperature sensor.

2. Features and benefits

- ARM Cortex-M4 core (version r0p1):
 - ◆ ARM Cortex-M4 processor, running at a frequency of up to 220 MHz.
 - ◆ The LPC5460x/61x devices operate at CPU frequencies of up to 180 MHz. The LPC54628 device operates at CPU frequencies of up to 220 MHz.
 - ◆ Floating Point Unit (FPU) and Memory Protection Unit (MPU).
 - ◆ ARM Cortex-M4 built-in Nested Vectored Interrupt Controller (NVIC).
 - ◆ Non-maskable Interrupt (NMI) input with a selection of sources.
 - ◆ Serial Wire Debug (SWD) with six instruction breakpoints, two literal comparators, and four watch points. Includes Serial Wire Output and ETM Trace for enhanced debug capabilities, and a debug timestamp counter.
 - ◆ System tick timer.



- On-chip memory:
 - ◆ Up to 512 KB on-chip flash program memory with flash accelerator and 256 byte page erase and write.
 - ◆ Up to 200 KB total SRAM consisting of 160 KB contiguous main SRAM and an additional 32 KB SRAM on the I&D buses. 8 KB of SRAM bank intended for USB traffic.
 - ◆ 16 KB of EEPROM.
- ROM API support:
 - ◆ Flash In-Application Programming (IAP) and In-System Programming (ISP).
 - ◆ ROM-based USB drivers (HID, CDC, MSC, and DFU). Flash updates via USB.
 - ◆ Booting from valid user code in flash, USART, SPI, and I²C.
 - ◆ Legacy, Single, and Dual image boot.
 - ◆ OTP API for programming OTP memory.
 - ◆ Random Number Generator (RNG) API.
- Serial interfaces:
 - ◆ Flexcomm Interface contains up to ten serial peripherals. Each Flexcomm Interface can be selected by software to be a USART, SPI, or I²C interface. Two Flexcomm Interfaces also include an I²S interface. Each Flexcomm Interface includes a FIFO that supports USART, SPI, and I²S if supported by that Flexcomm Interface. A variety of clocking options are available to each Flexcomm Interface and include a shared fractional baud-rate generator.
 - ◆ I²C-bus interfaces support Fast-mode and Fast-mode Plus with data rates of up to 1Mbit/s and with multiple address recognition and monitor mode. Two sets of true I²C pads also support High Speed Mode (3.4 Mbit/s) as a slave.
 - ◆ Two ISO 7816 Smart Card Interfaces with DMA support.
 - ◆ USB 2.0 high-speed host/device controller with on-chip high-speed PHY.
 - ◆ USB 2.0 full-speed host/device controller with on-chip PHY and dedicated DMA controller supporting crystal-less operation in device mode using software library. See Technical note TN00032 for more details.
 - ◆ SPIFI with XIP feature uses up to four data lines to access off-chip SPI/DSPi/QSPi flash memory at a much higher rate than standard SPI or SSP interfaces.
 - ◆ Ethernet MAC with MII/RMII interface with Audio Video Bridging (AVB) support and dedicated DMA controller.
 - ◆ Two CAN FD modules with dedicated DMA controller.
- Digital peripherals:
 - ◆ DMA controller with 30 channels and up to 24 programmable triggers, able to access all memories and DMA-capable peripherals.
 - ◆ LCD Controller supporting both Super-Twisted Nematic (STN) and Thin-Film Transistor (TFT) displays. It has a dedicated DMA controller, selectable display resolution (up to 1024 x 768 pixels), and supports up to 24-bit true-color mode.
 - ◆ External Memory Controller (EMC) provides support for asynchronous static memory devices such as RAM, ROM and flash, in addition to dynamic memories such as single data rate SDRAM with an SDRAM clock of up to 100 MHz. EMC bus width (bit) on TFBGA180, TFBGA100, and LQFP100 and packages supports up to 8/16 data line wide static memory, in addition to dynamic memories, such as, SDRAM (2 banks only) with an SDRAM clock of up to 100 MHz.
 - ◆ Secured digital input/output (SD/MMC and SDIO) card interface with DMA support.

- ◆ CRC engine block can calculate a CRC on supplied data using one of three standard polynomials with DMA support.
- ◆ Up to 171 General-Purpose Input/Output (GPIO) pins.
- ◆ GPIO registers are located on the AHB for fast access. The DMA supports GPIO ports.
- ◆ Up to eight GPIOs can be selected as Pin Interrupts (PINT), triggered by rising, falling or both input edges.
- ◆ Two GPIO Grouped Interrupts (GINT) enable an interrupt based on a logical (AND/OR) combination of input states.
- ◆ CRC engine.
- Analog peripherals:
 - ◆ 12-bit ADC with 12 input channels and with multiple internal and external trigger inputs and sample rates of up to 5.0 MSamples/sec. The ADC supports two independent conversion sequences.
 - ◆ Integrated temperature sensor connected to the ADC.
- DMIC subsystem including a dual-channel PDM microphone interface, flexible decimators, 16 entry FIFOs, optional DC locking, hardware voice activity detection, and the option to stream the processed output data to I²S.
- Timers:
 - ◆ Five 32-bit general purpose timers/counters, four of which support up to four capture inputs and four compare outputs, PWM mode, and external count input. Specific timer events can be selected to generate DMA requests. The fifth timer does not have external pin connections and may be used for internal timing operations.
 - ◆ SCTimer/PWM with 8 input and 10 output functions (including capture and match). Inputs and outputs can be routed to/from external pins and internally to or from selected peripherals. Internally, the SCTimer/PWM supports 10 match/captures, 10 events, and 10 states.
 - ◆ 32-bit Real-time clock (RTC) with 1 s resolution running in the always-on power domain. A timer in the RTC can be used for wake-up from all low power modes including deep power-down, with 1 ms resolution.
 - ◆ Multiple-channel multi-rate 24-bit timer (MRT) for repetitive interrupt generation at up to four programmable, fixed rates.
 - ◆ Windowed Watchdog Timer (WWDT).
 - ◆ Repetitive Interrupt Timer (RIT) for debug time stamping and for general purpose use.
- Security features:
 - ◆ enhanced Code Read Protection (eCRP) to protect user code.
 - ◆ OTP memory for ECRP settings, and user application specific data.
 - ◆ Secure Hash Algorithm (SHA1/SHA2) module with dedicated DMA controller.
- Clock generation:
 - ◆ 12 MHz internal Free Running Oscillator (FRO). This oscillator provides a selectable 48 MHz or 96 MHz output, and a 12 MHz output (divided down from the selected higher frequency) that can be used as a system clock. The FRO is trimmed to ± 1 % accuracy over the entire voltage and temperature range.
 - ◆ External clock input for clock frequencies of up to 25 MHz.
 - ◆ Crystal oscillator with an operating range of 1 MHz to 25 MHz.

- ◆ Watchdog Oscillator (WDTOSC) with a frequency range of 6 kHz to 1.5 MHz.
- ◆ 32.768 kHz low-power RTC oscillator.
- ◆ System PLL allows CPU operation up to the maximum CPU rate and can run from the main oscillator, the internal FRO, the watchdog oscillator or the 32.768 KHz RTC oscillator.
- ◆ Two additional PLLs for USB clock and audio subsystem.
- ◆ Independent clocks for the SPIFI interface, ADC, USBs, and the audio subsystem.
- ◆ Clock output function with divider.
- ◆ Frequency measurement unit for measuring the frequency of any on-chip or off-chip clock signal.
- Power control:
 - ◆ Programmable PMU (Power Management Unit) to minimize power consumption and to match requirements at different performance levels.
 - ◆ Reduced power modes: sleep, deep-sleep, and deep power-down.
 - ◆ Wake-up from deep-sleep modes due to activity on the USART, SPI, and I2C peripherals when operating as slaves.
 - ◆ Ultra-low power Micro-tick Timer, running from the Watchdog oscillator that can be used to wake up the device from low power modes.
 - ◆ Power-On Reset (POR).
 - ◆ Brown-Out Detect (BOD) with separate thresholds for interrupt and forced reset.
- Single power supply 1.71 V to 3.6 V.
- Power-On Reset (POR).
- Brown-Out Detect (BOD) with separate thresholds for interrupt and forced reset.
- JTAG boundary scan supported.
- 128 bit unique device serial number for identification.
- Operating temperature range $-40\text{ }^{\circ}\text{C}$ to $+105\text{ }^{\circ}\text{C}$.
- Available in TFBGA180, TFBGA100, LQFP208, and LQFP100 packages.

3. Ordering information

Table 1. Ordering information

Type number	Package		
	Name	Description	Version
LPC54605J256ET180	TFBGA180	thin fine-pitch ball grid array package; 180 balls; body 12 ´ 12 ´ 0.8 mm	SOT570-3
LPC54605J512ET180	TFBGA180	thin fine-pitch ball grid array package; 180 balls; body 12 ´ 12 ´ 0.8 mm	SOT570-3
LPC54605J256BD100	LQFP100	plastic low profile quad flat package; 100 leads; body 14 × 14 × 1.4 mm	SOT407-1
LPC54605J512BD100	LQFP100	plastic low profile quad flat package; 100 leads; body 14 × 14 × 1.4 mm	SOT407-1
LPC54605J256ET100	TFBGA100	plastic thin fine-pitch ball grid array package; 100 balls; body 9 × 9 × 0.7 mm	SOT926-1
LPC54605J512ET100	TFBGA100	plastic thin fine-pitch ball grid array package; 100 balls; body 9 × 9 × 0.7 mm	SOT926-1
LPC54606J256ET100	TFBGA100	plastic thin fine-pitch ball grid array package; 100 balls; body 9 × 9 × 0.7 mm	SOT926-1
LPC54606J256BD100	LQFP100	plastic low profile quad flat package; 100 leads; body 14 × 14 × 1.4 mm	SOT407-1
LPC54606J256ET180	TFBGA180	thin fine-pitch ball grid array package; 180 balls; body 12 ´ 12 ´ 0.8 mm	SOT570-3
LPC54606J512ET100	TFBGA100	plastic thin fine-pitch ball grid array package; 100 balls; body 9 × 9 × 0.7 mm	SOT926-1
LPC54606J512BD100	LQFP100	plastic low profile quad flat package; 100 leads; body 14 × 14 × 1.4 mm	SOT407-1
LPC54606J512BD208	LQFP208	plastic low profile quad flat package; 208 leads; body 28 × 28 × 1.4 mm	SOT459-1
LPC54607J256ET180	TFBGA180	thin fine-pitch ball grid array package; 180 balls; body 12 ´ 12 ´ 0.8 mm	SOT570-3
LPC54607J512ET180	TFBGA180	thin fine-pitch ball grid array package; 180 balls; body 12 ´ 12 ´ 0.8 mm	SOT570-3
LPC54607J256BD208	LQFP208	plastic low profile quad flat package; 208 leads; body 28 × 28 × 1.4 mm	SOT459-1
LPC54608J512ET180	TFBGA180	thin fine-pitch ball grid array package; 180 balls; body 12 ´ 12 ´ 0.8 mm	SOT570-3
LPC54608J512BD208	LQFP208	plastic low profile quad flat package; 208 leads; body 28 × 28 × 1.4 mm	SOT459-1
LPC54616J256ET180	TFBGA180	thin fine-pitch ball grid array package; 180 balls; body 12 ´ 12 ´ 0.8 mm	SOT570-3
LPC54616J512ET100	TFBGA100	plastic thin fine-pitch ball grid array package; 100 balls; body 9 × 9 × 0.7 mm	SOT926-1
LPC54616J512BD100	LQFP100	plastic low profile quad flat package; 100 leads; body 14 × 14 × 1.4 mm	SOT407-1
LPC54616J512BD208	LQFP208	plastic low profile quad flat package; 208 leads; body 28 × 28 × 1.4 mm	SOT459-1
LPC54618J512ET180	TFBGA180	thin fine-pitch ball grid array package; 180 balls; body 12 ´ 12 ´ 0.8 mm	SOT570-3
LPC54618J512BD208	LQFP208	plastic low profile quad flat package; 208 leads; body 28 × 28 × 1.4 mm	SOT459-1
LPC54628J512ET180	TFBGA180	thin fine-pitch ball grid array package; 180 balls; body 12 ´ 12 ´ 0.8 mm	SOT570-3

3.1 Ordering options

Table 2. Ordering options

Type number	Package Name	Frequency/MHz	Flash/kB	SRAM/kB	FS USB	HS USB	Ethernet AVB	Classic CAN	CAN FD	LCD	Flexcomm Interface	EMC data bus width (bit)	GPIO	SHA
LPC54628 devices (HS/FS USB, Ethernet, CAN FD, CAN 2.0, LCD, SHA)														
LPC54628J512ET180	TFBGA180	220	512	200	yes	yes	yes	yes	yes	yes	10	8/16	145	yes
LPC54618 devices (HS/FS USB, Ethernet, CAN FD, CAN 2.0, LCD)														
LPC54618J512ET180	TFBGA180	180	512	200	yes	yes	yes	yes	yes	yes	10	8/16	145	no
LPC54618J512BD208	LQFP208	180	512	200	yes	yes	yes	yes	yes	yes	10	8/16/32	171	no
LPC54616 devices (HS/FS USB, Ethernet, CAN FD, CAN 2.0)														
LPC54616J256ET180	TFBGA180	180	256	136	yes	yes	yes	yes	yes	no	10	8/16	145	no
LPC54616J512BD208	LQFP208	180	512	200	yes	yes	yes	yes	yes	no	10	8/16/32	171	no
LPC54616J512ET100	TFBGA100	180	512	200	yes	yes	yes	yes	yes	no	9	8/16	64	no
LPC54616J512BD100	LQFP100	180	512	200	yes	yes	yes	yes	yes	no	9	8/16	64	no
LPC54608 devices (HS/FS USB, Ethernet, CAN 2.0, LCD)														
LPC54608J512ET180	TFBGA180	180	512	200	yes	yes	yes	yes	no	yes	10	8/16	145	no
LPC54608J512BD208	LQFP208	180	512	200	yes	yes	yes	yes	no	yes	10	8/16/32	171	no
LPC54607 devices (HS/FS USB, LCD)														
LPC54607J256ET180	TFBGA180	180	256	136	yes	yes	no	no	no	yes	10	8/16	145	no
LPC54607J512ET180	TFBGA180	180	512	200	yes	yes	no	no	no	yes	10	8/16	145	no
LPC54607J256BD208	LQFP208	180	256	136	yes	yes	no	no	no	yes	10	8/16/32	171	no
LPC54606 devices (HS/FS USB, Ethernet, CAN 2.0)														
LPC54606J256ET180	TFBGA180	180	256	136	yes	yes	yes	yes	no	no	10	8/16	145	no
LPC54606J512BD208	LQFP208	180	512	200	yes	yes	yes	yes	no	no	10	8/16/32	171	no
LPC54606J256ET100	TFBGA100	180	256	136	yes	yes	yes	yes	no	no	9	8/16	64	no
LPC54606J512ET100	TFBGA100	180	512	200	yes	yes	yes	yes	no	no	9	8/16	64	no
LPC54606J256BD100	LQFP100	180	256	136	yes	yes	yes	yes	no	no	9	8/16	64	no
LPC54606J512BD100	LQFP100	180	512	200	yes	yes	yes	yes	no	no	9	8/16	64	no
LPC54605 devices (HS/FS USB)														
LPC54605J256ET180	TFBGA180	180	256	136	yes	yes	no	no	no	no	10	8/16	145	no
LPC54605J512ET180	TFBGA180	180	512	200	yes	yes	no	no	no	no	10	8/16	145	no
LPC54605J256BD100	LQFP100	180	256	136	yes	yes	no	no	no	no	9	8/16	64	no
LPC54605J512BD100	LQFP100	180	512	200	yes	yes	no	no	no	no	9	8/16	64	no
LPC54605J256ET100	TFBGA100	180	256	136	yes	yes	no	no	no	no	9	8/16	64	no
LPC54605J512ET100	TFBGA100	180	512	200	yes	yes	no	no	no	no	9	8/16	64	no

4. Marking

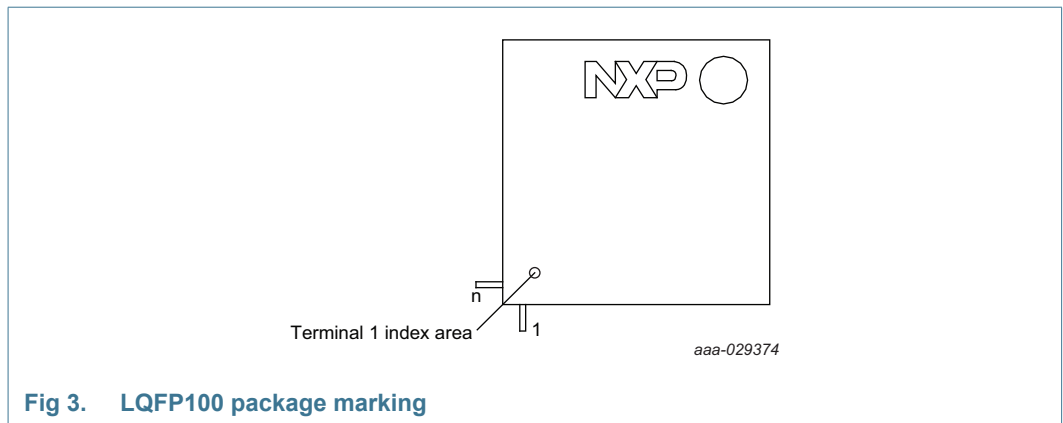
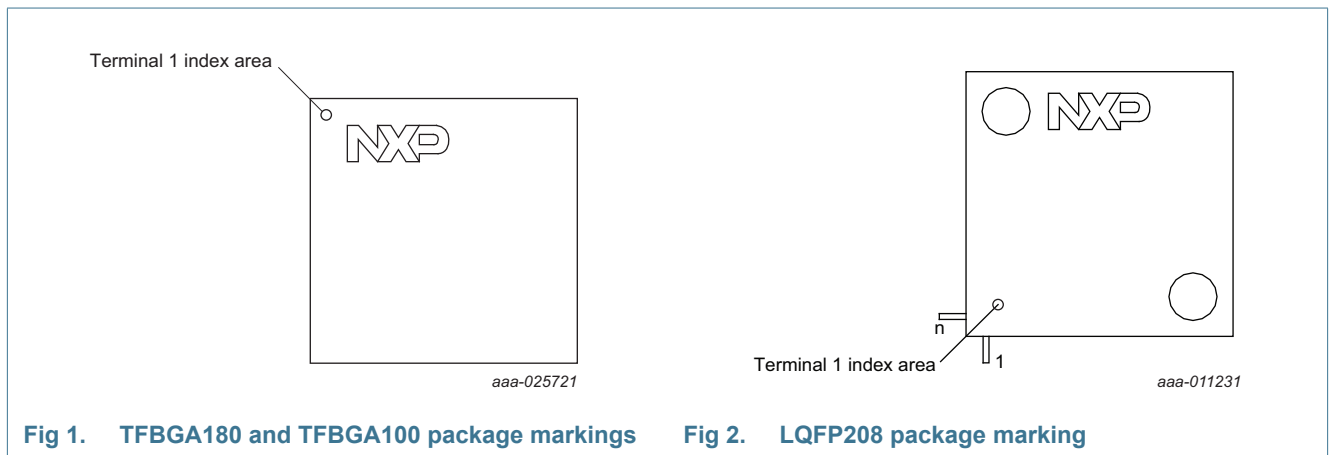

The LPC546xx TFPGA180 and TFPGA100 packages have the following top-side marking:

- First line: LPC546xxJyyy
 - yyy: flash size
- Second line: ET180 or ET100
- Third line: xxxxxxxxxxxx
- Fourth line: xxxyywwx[R]x
 - yyww: Date code with yy = year and ww = week.
 - xR = boot code version and device revision.

The LPC546xx LQFP208 and LQFP100 packages have the following top-side marking:

- First line: LPC546xxJyyy
 - yyy: flash size
- Second line: BD208 or BD100
- Third line: xxxxxxxxxxxx
- Fourth line: xxxyywwx[R]x

- yyww: Date code with yy = year and ww = week.
- xR = Boot code version and device revision.

Table 3. Device revision table

Revision identifier (R)	Revision description
1A	Initial device revision with Boot ROM version 19.1

5. Block diagram

[Figure 4](#) shows the LPC546xx block diagram. In this figure, orange shaded blocks support general purpose DMA and yellow shaded blocks include dedicated DMA control.

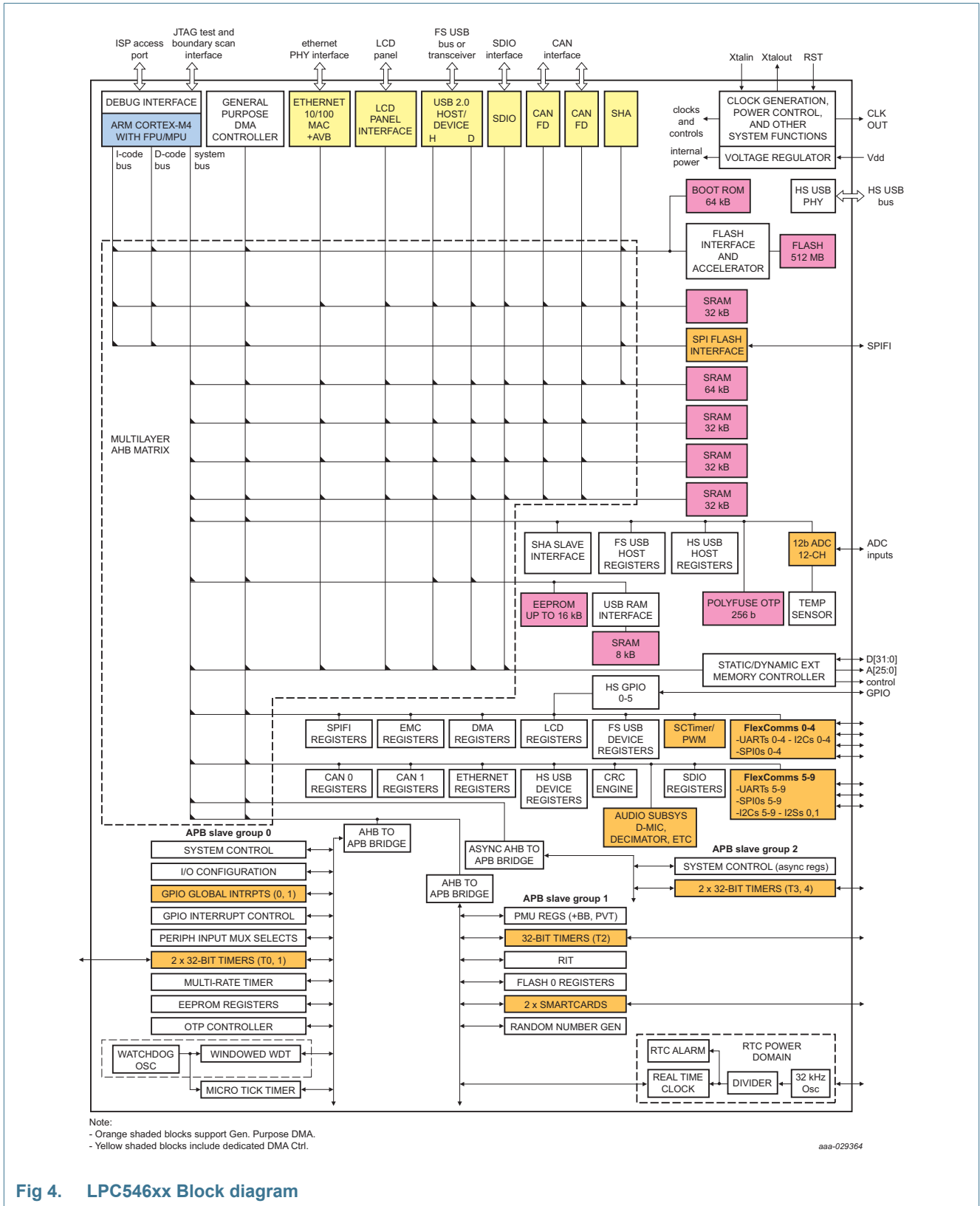
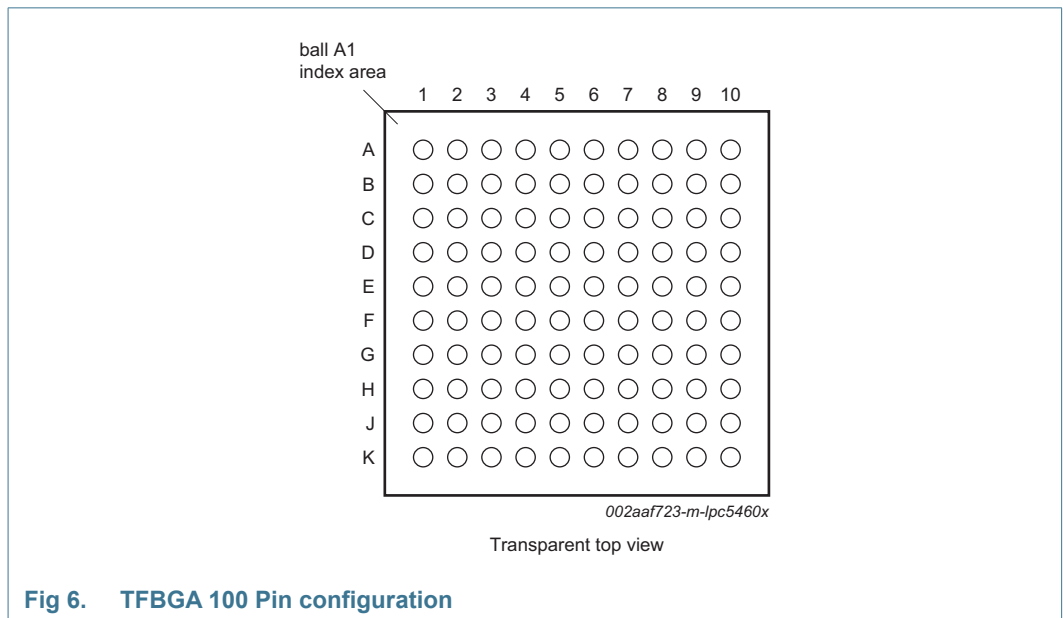
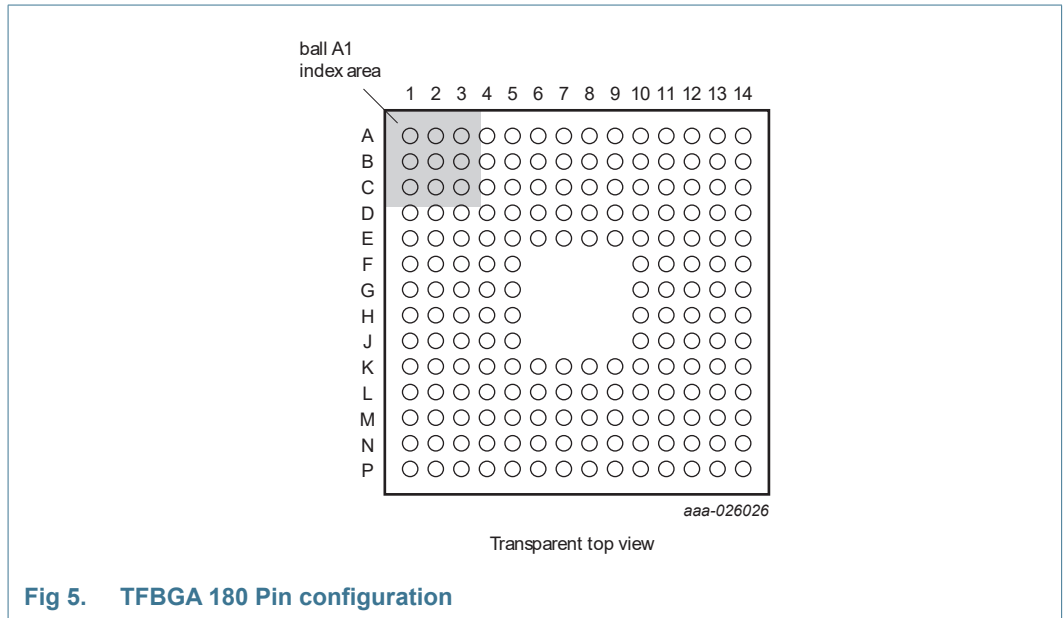
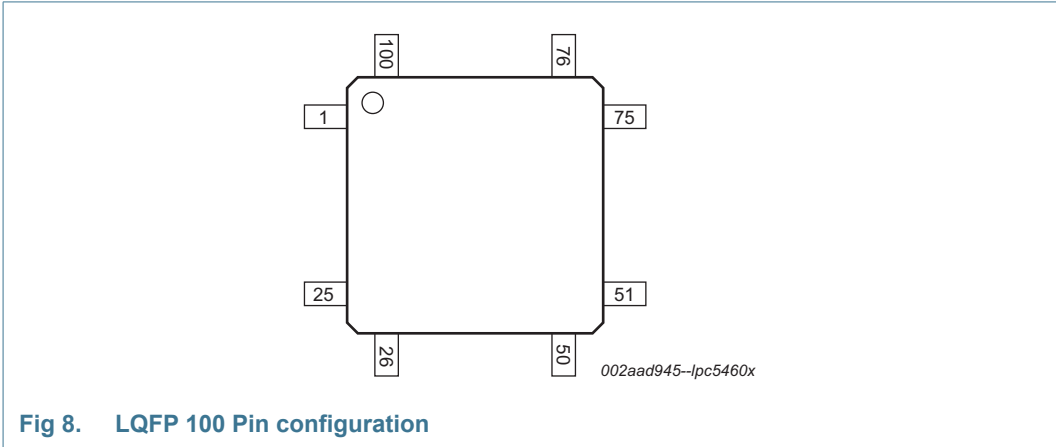
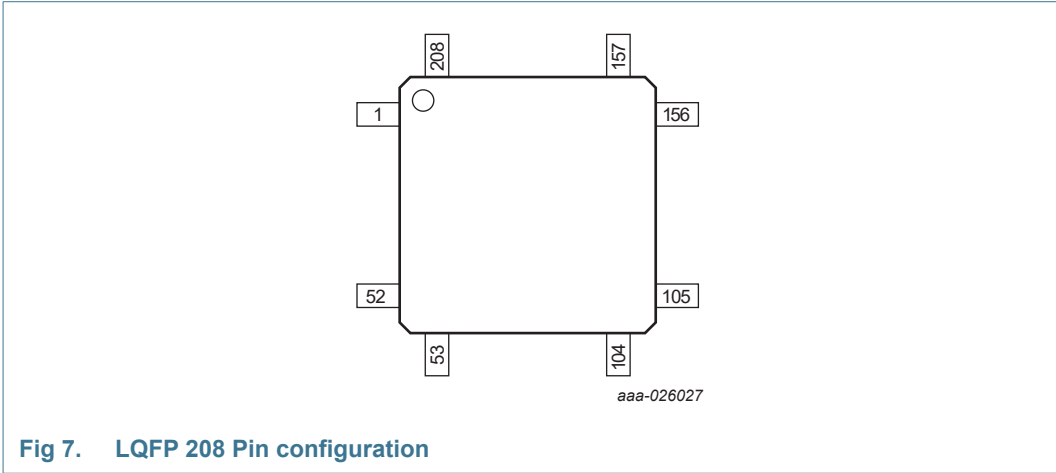

Fig 4. LPC546xx Block diagram

6. Pinning information

6.1 Pinning





6.2 Pin description

On the LPC546xx, digital pins are grouped into several ports. Each digital pin can support several different digital functions (including General Purpose I/O (GPIO)) and an additional analog function.

Table 4. Pin description

Symbol	100-pin, TFBGA	180-pin, TFBGA	208-pin, LQFP	100-pin, LQFP		Reset state [1]	Type	Description
PIO0_0	C4	D6	196	93	[2]	PU	I/O	PIO0_0 — General-purpose digital input/output pin. Remark: In ISP mode, this pin is set to the Flexcomm 3 SPI SCK function.
							I	CAN1_RD — Receiver input for CAN 1.
							I/O	FC3_SCK — Flexcomm 3: USART or SPI clock.
							O	CTimer_MAT0 — Match output 0 from Timer 0.
							I	SCT0_GPIO — Pin input 0 to SCTimer/PWM.
PIO0_1	A1	A1	207	100	[2]	PU	I/O	PIO0_1 — General-purpose digital input/output pin. Remark: In ISP mode, this pin is set to the Flexcomm 3 SPI SSEL0 function.
							O	CAN1_TD — Transmitter output for CAN 1.
							I/O	FC3_CTS_SDA_SSEL0 — Flexcomm 3: USART clear-to-send, I2C data I/O, SPI Slave Select 0.
							I	CT0_CAP0 — Capture input 0 to Timer 0.
							I	SCT0_GPI1 — Pin input 1 to SCTimer/PWM.
PIO0_2/ TRST	A7	E9	174	83	[2]	PU	I/O	PIO0_2 — General-purpose digital input/output pin. In boundary scan mode: TRST (Test Reset). Remark: In ISP mode, this pin is set to the Flexcomm 3 SPI MISO function.
							I/O	FC3_TXD_SCL_MISO — Flexcomm 3: USART transmitter, I2C clock, SPI master-in/slave-out data.
							I	CT0_CAP1 — Capture input 1 to Timer 0.
							O	SCT0_OUT0 — SCTimer/PWM output 0.
							I	SCT0_GPI[2] — Pin input 2 to SCTimer/PWM.
I/O	EMC_D[0] — External Memory interface data [0].							

Table 4. Pin description ...continued

Symbol	100-pin, TFBGA	180-pin, TFBGA	208-pin, LQFP	100-pin, LQFP		Reset state [1]	Type	Description
PIO0_3/ TCK	A6	A10	178	85	[2]	PU	I/O	PIO0_3 — General-purpose digital input/output pin. In boundary scan mode: TCK (Test Clock In). Remark: In ISP mode, this pin is set to the Flexcomm 3 SPI MOSI function.
							I/O	FC3_RXD_SDA_MOSI — Flexcomm 3: USART receiver, I2C data I/O, SPI master-out/slave-in data.
							O	CT0_MAT1 — Match output 1 from Timer 0.
							O	SCT0_OUT1 — SCTimer/PWM output 1.
							I	SCT0_GPI3 — Pin input 3 to SCTimer/PWM.
								R — Reserved.
							I/O	EMC_D[1] — External Memory interface data [1].
PIO0_4/ TMS	B6	C8	185	87	[2]	PU	I/O	PIO0_4 — General-purpose digital input/output pin. In boundary scan mode: TMS (Test Mode Select). Remark: The state of this pin at Reset in conjunction with PIO0_5 and PIO0_6 will determine the boot source for the part or if ISP handler is invoked. See the Boot Process chapter in UM10912 for more details.
							I	CAN0_RD — Receiver input for CAN 0.
							I/O	FC4_SCK — Flexcomm 4: USART or SPI clock.
							I	CT3_CAP0 — Capture input 0 to Timer 3.
							I	SCT0_GPI4 — Pin input 4 to SCTimer/PWM.
								R — Reserved.
							I/O	EMC_D[2] — External Memory interface data [2].
PIO0_5/ TDI	A5	E7	189	89	[2]	PU	I/O	PIO0_5 — General-purpose digital input/output pin. In boundary scan mode: TDI (Test Data In). Remark: The state of this pin at Reset in conjunction with PIO0_4 and PIO0_6 will determine the boot source for the part or if ISP handler is invoked. See the Boot Process chapter in UM10912 for more details.
							O	CAN0_TD — Transmitter output for CAN 0.
							I/O	FC4_RXD_SDA_MOSI — Flexcomm 4: USART receiver, I2C data I/O, SPI master-out/slave-in data.
							O	CT3_MAT0 — Match output 0 from Timer 3.
							I	SCT0_GPI5 — Pin input 5 to SCTimer/PWM.
								R — Reserved.
							I/O	EMC_D[3] — External Memory interface data [3].
I/O	ENET_MDIO — Ethernet management data I/O.							

Table 4. Pin description ...continued

Symbol	100-pin, TFBGA	180-pin, TFBGA	208-pin, LQFP	100-pin, LQFP		Reset state [1]	Type	Description
PIO0_6/ TDO	A4	A5	191	90	[2]	PU	I/O	PIO0_6 — General-purpose digital input/output pin. In boundary scan mode: TDO (Test Data Out). Remark: The state of this pin at Reset in conjunction with PIO0_4 and PIO0_5 will determine the boot source for the part or if ISP handler is invoked. See the Boot Process chapter in UM10912 for more details.
							I/O	FC3_SCK — Flexcomm 3: USART or SPI clock.
							I	CT3_CAP1 — Capture input 1 to Timer 3.
							O	CT4_MAT0 — Match output 0 from Timer 4.
							I	SCT0_GPI6 — Pin input 6 to SCTimer/PWM.
								R — Reserved.
							I/O	EMC_D[4] — External Memory interface data [4].
PIO0_7	F9	H12	125	61	[2]	PU	I/O	PIO0_7 — General-purpose digital input/output pin.
							I/O	FC3_RTS_SCL_SSEL1 — Flexcomm 3: USART request-to-send, I2C clock, SPI slave select 1.
							O	SD_CLK — SD/MMC clock.
							I/O	FC5_SCK — Flexcomm 5: USART or SPI clock.
							I/O	FC1_SCK — Flexcomm 1: USART or SPI clock.
							O	PDM1_CLK — Clock for PDM interface 1, for digital microphone.
							I/O	EMC_D[5] — External Memory interface data [5].
PIO0_8	E9	H10	133	64	[2]	PU	I/O	PIO0_8 — General-purpose digital input/output pin.
							I/O	FC3_SSEL3 — Flexcomm 3: SPI slave select 3.
							I/O	SD_CMD — SD/MMC card command I/O.
							I/O	FC5_RXD_SDA_MOSI — Flexcomm 5: USART receiver, I2C data I/O, SPI master-out/slave-in data.
							O	SWO — Serial Wire Debug trace output.
							I	PDM1_DATA — Data for PDM interface 1 (digital microphone).
							I/O	EMC_D[6] — External Memory interface data [6].

Table 4. Pin description ...continued

Symbol	100-pin, TFBGA	180-pin, TFBGA	208-pin, LQFP	100-pin, LQFP		Reset state [1]	Type	Description
PIO0_9	E10	G12	136	65	[2]	PU	I/O	PIO0_9 — General-purpose digital input/output pin.
							I/O	FC3_SSEL2 — Flexcomm 3: SPI slave select 2.
							O	SD_POW_EN — SD/MMC card power enable.
							I/O	FC5_TXD_SCL_MISO — Flexcomm 5: USART transmitter, I2C clock, SPI master-in/slave-out data.
								R — Reserved.
							I/O	SC11_IO — SmartCard Interface 1 data I/O.
							I/O	EMC_D[7] — External Memory interface data [7].
PIO0_10/ ADC0_0	J1	P2	50	23	[4]	PU	I/O; AI	PIO0_10/ADC0_0 — General-purpose digital input/output pin. ADC input channel 0 if the DIGIMODE bit is set to 0 in the IOCON register for this pin.
							I/O	FC6_SCK — Flexcomm 6: USART, SPI, or I2S clock.
							I	CT2_CAP2 — Capture input 2 to Timer 2.
							O	CT2_MAT0 — Match output 0 from Timer 2.
							I/O	FC1_TXD_SCL_MISO — Flexcomm 1: USART transmitter, I2C clock, SPI master-in/slave-out data.
								R — Reserved.
							O	SWO — Serial Wire Debug trace output.
PIO0_11/ ADC0_1	K1	L3	51	24	[4]	PU	I/O; AI	PIO0_11/ADC0_1 — General-purpose digital input/output pin. ADC input channel 1 if the DIGIMODE bit is set to 0 in the IOCON register for this pin.
							I/O	FC6_RXD_SDA_MOSI_DATA — Flexcomm 6: USART receiver, I2C data I/O, SPI master-out/slave-in data, I2S data I/O.
							O	CT2_MAT2 — Match output 2 from Timer 2.
							I	FREQME_GPIO_CLK_A — Frequency Measure pin clock input A.
								R — Reserved.
								R — Reserved.
							I	SWCLK — Serial Wire Debug clock. This is the default function after booting.

Table 4. Pin description ...continued

Symbol	100-pin, TFBGA	180-pin, TFBGA	208-pin, LQFP	100-pin, LQFP		Reset state [1]	Type	Description
PIO0_12/ ADC0_2	J2	M3	52	25	[4]	PU	I/O; AI	PIO0_12/ADC0_2 — General-purpose digital input/output pin. ADC input channel 2 if the DIGIMODE bit is set to 0 in the IOCON register for this pin.
							I/O	FC3_TXD_SCL_MISO — Flexcomm 3: USART transmitter, I2C clock, SPI master-in/slave-out data.
								R — Reserved.
							I	FREQME_GPIO_CLK_B — Frequency Measure pin clock input B.
							I	SCT0_GPI7 — Pin input 7 to SCTimer/PWM.
								R — Reserved.
PIO0_13	C10	F11	141	67	[3]	Z	I/O	PIO0_13 — General-purpose digital input/output pin. Remark: In ISP mode, this pin is set to the Flexcomm 1 I2C SDA function.
							I/O	FC1_CTS_SDA_SSEL0 — Flexcomm 1: USART clear-to-send, I2C data I/O, SPI Slave Select 0.
							I	UTICK_CAP0 — Micro-tick timer capture input 0.
							I	CT0_CAP0 — Capture input 0 to Timer 0.
							I	SCT0_GPI0 — Pin input 0 to SCTimer/PWM.
								R — Reserved.
								R — Reserved.
							I	ENET_RXD0 — Ethernet receive data 0.
PIO0_14	D9	E13	144	69	[3]	Z	I/O	PIO0_14 — General-purpose digital input/output pin. Remark: In ISP mode, this pin is set to the Flexcomm 1 I2C SCL function.
							I/O	FC1_RTS_SCL_SSEL1 — Flexcomm 1: USART request-to-send, I2C clock, SPI slave select 1.
							I	UTICK_CAP1 — Micro-tick timer capture input 1.
							I	CT0_CAP1 — Capture input 1 to Timer 0.
							I	SCT0_GPI1 — Pin input 1 to SCTimer/PWM.
								R — Reserved.
								R — Reserved.
							I	ENET_RXD1 — Ethernet receive data 1.

Table 4. Pin description ...continued

Symbol	100-pin, TFBGA	180-pin, TFBGA	208-pin, LQFP	100-pin, LQFP		Reset state [1]	Type	Description
PIO0_15/ ADC0_3	K2	L4	53	26	[4]	PU	I/O; AI	PIO0_15/ADC0_3 — General-purpose digital input/output pin. ADC input channel 3 if the DIGIMODE bit is set to 0 in the IOCON register for this pin.
							I/O	FC6_CTS_SDA_SSEL0 — Flexcomm 6: USART clear-to-send, I2C data I/O, SPI Slave Select 0.
							I	UTICK_CAP2 — Micro-tick timer capture input 2.
							I	CT4_CAP0 — Capture input 4 to Timer 0.
							O	SCT0_OUT2 — SCTimer/PWM output 2.
								R — Reserved.
							O	EMC_WEN — External memory interface Write Enable (active low).
PIO0_16/ ADC0_4	H3	M4	54	27	[4]	PU	I/O; AI	PIO0_16/ADC0_4 — General-purpose digital input/output pin. ADC input channel 4 if the DIGIMODE bit is set to 0 in the IOCON register for this pin.
							I/O	FC4_TXD_SCL_MISO — Flexcomm 4: USART transmitter, I2C clock, SPI master-in/slave-out data.
							O	CLKOUT — Output of the CLKOUT function.
							I	CT1_CAP0 — Capture input 0 to Timer 1.
								R — Reserved.
								R — Reserved.
							O	EMC_CSN[0] — External memory interface static chip select 0 (active low).
PIO0_17	B10	E14	146	70	[2]	PU	I/O	PIO0_17 — General-purpose digital input/output pin.
							I/O	FC4_SSEL2 — Flexcomm 4: SPI slave select 2.
							I	SD_CARD_DET_N — SD/MMC card detect (active low).
							I	SCT0_GPI7 — Pin input 7 to SCTimer/PWM.
							O	SCT0_OUT0 — SCTimer/PWM output 0.
								R — Reserved.
							O	EMC_OEN — External memory interface output enable (active low)
O	ENET_TXD1 — Ethernet transmit data 1.							

Table 4. Pin description ...continued

Symbol	100-pin, TFBGA	180-pin, TFBGA	208-pin, LQFP	100-pin, LQFP		Reset state [1]	Type		Description
PIO0_18	C9	C14	150	72	[2]	PU	I/O		PIO0_18 — General-purpose digital input/output pin.
									FC4_CTS_SDA_SSEL0 — Flexcomm 4: USART clear-to-send, I2C data I/O, SPI Slave Select 0.
								I	SD_WR_PRT — SD/MMC write protect.
								O	CT1_MAT0 — Match output 0 from Timer 1.
								O	SCT0_OUT1 — SCTimer/PWM output 1.
								O	SCI1_SCLK — SmartCard Interface 1 clock.
								O	EMC_A[0] — External memory interface address 0.
PIO0_19	C5	C6	193	91	[2]	PU	I/O		PIO0_19 — General-purpose digital input/output pin.
									FC4_RTS_SCL_SSEL1 — Flexcomm 4: USART request-to-send, I2C clock, SPI slave select 1.
								I	UTICK_CAP0 — Micro-tick timer capture input 0.
								O	CT0_MAT2 — Match output 2 from Timer 0.
								O	SCT0_OUT2 — SCTimer/PWM output 2.
									R — Reserved.
								O	EMC_A[1] — External memory interface address 1.
I/O	FC7_TXD_SCL_MISO_WS — Flexcomm 7: USART transmitter, I2C clock, SPI master-in/slave-out data I/O, I2S word-select/frame.								
PIO0_20	C8	D13	153	74	[2]	PU	I/O		PIO0_20 — General-purpose digital input/output pin.
									FC3_CTS_SDA_SSEL0 — Flexcomm 3: USART clear-to-send, I2C data I/O, SPI Slave Select 0.
								O	CT1_MAT1 — Match output 1 from Timer 1.
								I	CT3_CAP3 — Capture input 3 to Timer 3.
								I	SCT0_GPI2 — Pin input 2 to SCTimer/PWM.
								I/O	SCI0_IO — SmartCard Interface 0 data I/O.
								O	EMC_A[2] — External memory interface address 2.
I/O	FC7_RXD_SDA_MOSI_DATA — Flexcomm 7: USART receiver, I2C data I/O, SPI master-out/slave-in data, I2S data I/O.								
PIO0_21	B9	C13	158	77	[2]	PU	I/O		PIO0_21 — General-purpose digital input/output pin.
									FC3_RTS_SCL_SSEL1 — Flexcomm 3: USART request-to-send, I2C clock, SPI slave select 1.
								I	UTICK_CAP3 — Micro-tick timer capture input 3.
								O	CT3_MAT3 — Match output 3 from Timer 3.
								I	SCT0_GPI3 — Pin input 3 to SCTimer/PWM.
								O	SCI0_SCLK — SmartCard Interface 0 clock.
								O	EMC_A[3] — External memory interface address 3.
I/O	FC7_SCK — Flexcomm 7: USART, SPI, or I2S clock.								

Table 4. Pin description ...continued

Symbol	100-pin, TFBGA	180-pin, TFBGA	208-pin, LQFP	100-pin, LQFP		Reset state [1]	Type	Description
PIO0_22	B8	B12	163	80	[2][8]	PU	I/O	PIO0_22 — General-purpose digital input/output pin.
							I/O	FC6_TXD_SCL_MISO_WS — Flexcomm 6: USART transmitter, I2C clock, SPI master-in/slave-out data I/O, I2S word-select/frame.
							I	UTICK_CAP1 — Micro-tick timer capture input 1.
							I	CT3_CAP3 — Capture input 3 to Timer 3.
							O	SCT0_OUT3 — SCTimer/PWM output 3.
								R — Reserved.
								R — Reserved.
PIO0_23/ ADC0_11	K5	N7	71	35	[4]	PU	I/O; AI	PIO0_23/ADC0_11 — General-purpose digital input/output pin. ADC input channel 11 if the DIGIMODE bit is set to 0 in the IOCON register for this pin.
							I/O	MCLK — MCLK input or output for I2S and/or digital microphone.
							O	CT1_MAT2 — Match output 2 from Timer 1.
							O	CT3_MAT3 — Match output 3 from Timer 3.
							O	SCT0_OUT4 — SCTimer/PWM output 4.
								R — Reserved.
							I/O	SPIFI_CSN — SPI Flash Interface chip select (active low).
PIO0_24	J5	M7	76	38	[2]	PU	I/O	PIO0_24 — General-purpose digital input/output pin.
							I/O	FC0_RXD_SDA_MOSI — Flexcomm 0: USART receiver, I2C data I/O, SPI master-out/slave-in data.
							I/O	SD_D[0] — SD/MMC data 0.
							I	CT2_CAP0 — Capture input 0 to Timer 2.
							I	SCT0_GPI0 — Pin input 0 to SCTimer/PWM.
								R — Reserved.
							I/O	SPIFI_IO0 — Data bit 0 for the SPI Flash Interface.
PIO0_25	J6	K8	83	40	[2]	PU	I/O	PIO0_25 — General-purpose digital input/output pin.
							I/O	FC0_TXD_SCL_MISO — Flexcomm 0: USART transmitter, I2C clock, SPI master-in/slave-out data.
							I/O	SD_D[1] — SD/MMC data 1.
							I	CT2_CAP1 — Capture input 1 to Timer 2.
							I	SCT0_GPI1 — Pin input 1 to SCTimer/PWM.
								R — Reserved.
							I/O	SPIFI_IO1 — Data bit 1 for the SPI Flash Interface.

Table 4. Pin description ...continued

Symbol	100-pin, TFBGA	180-pin, TFBGA	208-pin, LQFP	100-pin, LQFP		Reset state [1]	Type	Description
PIO0_26	H10	M13	110	56	[2]	PU	I/O	PIO0_26 — General-purpose digital input/output pin.
							I/O	FC2_RXD_SDA_MOSI — Flexcomm 2: USART receiver, I2C data I/O, SPI master-out/slave-in data.
							O	CLKOUT — Output of the CLKOUT function.
							I	CT3_CAP2 — Capture input 2 to Timer 3.
							O	SCT0_OUT5 — SCTimer/PWM output 5.
							O	PDM0_CLK — Clock for PDM interface 0, for digital microphone.
							O	SPIFI_CLK — Clock output for the SPI Flash Interface.
							I	USB0_IDVALUE — Indicates to the transceiver whether connected as an A-device (USB0_ID LOW) or B-device (USB0_ID HIGH).
PIO0_27	H7	L9	87	42	[2]	PU	I/O	PIO0_27 — General-purpose digital input/output pin.
							I/O	FC2_TXD_SCL_MISO — Flexcomm 2: USART transmitter, I2C clock, SPI master-in/slave-out data.
								R — Reserved.
							O	CT3_MAT2 — Match output 2 from Timer 3.
							O	SCT0_OUT6 — SCTimer/PWM output 6.
							I	PDM0_DATA — Data for PDM interface 0 (digital microphone).
							I/O	SPIFI_IO3 — Data bit 3 for the SPI Flash Interface.
PIO0_28	J7	M9	91	44	[2]	PU	I/O	PIO0_28 — General-purpose digital input/output pin.
							I/O	FC0_SCK — Flexcomm 0: USART or SPI clock.
								R — Reserved.
							I	CT2_CAP3 — Capture 3 input to Timer 2.
							O	SCT0_OUT7 — SCTimer/PWM output 7.
							O	TRACEDATA[3] — Trace data bit 3.
							I/O	SPIFI_IO2 — Data bit 2 for the SPI Flash Interface.
I	USB0_OVERCURRENTN — USB0 bus overcurrent indicator (active low).							
PIO0_29	B7	B13	167	82	[2]	PU	I/O	PIO0_29 — General-purpose digital input/output pin. Remark: In ISP mode, this pin is set to the Flexcomm 0 USART RXD function.
							I/O	FC0_RXD_SDA_MOSI — Flexcomm 0: USART receiver, I2C data I/O, SPI master-out/slave-in data.
								R — Reserved.
							O	CT2_MAT3 — Match output 3 from Timer 2.
							O	SCT0_OUT8 — SCTimer/PWM output 8.
							O	TRACEDATA[2] — Trace data bit 2.

Table 4. Pin description ...continued

Symbol	100-pin, TFBGA	180-pin, TFBGA	208-pin, LQFP	100-pin, LQFP		Reset state [1]	Type	Description
PIO0_30	A2	A2	200	95	[2]	PU	I/O	PIO0_30 — General-purpose digital input/output pin. Remark: In ISP mode, this pin is set to the Flexcomm 0 USART TXD function.
							I/O	FC0_TXD_SCL_MISO — Flexcomm 0: USART transmitter, I2C clock, SPI master-in/slave-out data.
								R — Reserved.
							O	CT0_MAT0 — Match output 0 from Timer 0.
							O	SCT0_OUT9 — SCTimer/PWM output 9.
							O	TRACEDATA[1] — Trace data bit 1.
PIO0_31/ ADC0_5	K3	M5	55	28	[4]	PU	I/O; AI	PIO0_31/ADC0_5 — General-purpose digital input/output pin. ADC input channel 5 if the DIGIMODE bit is set to 0 in the IOCON register for this pin.
							I/O	FC0_CTS_SDA_SSEL0 — Flexcomm 0: USART clear-to-send, I2C data I/O, SPI Slave Select 0.
							I/O	SD_D[2] — SD/MMC data 2.
							O	CT0_MAT1 — Match output 1 from Timer 0.
							O	SCT0_OUT3 — SCTimer/PWM output 3.
							O	TRACEDATA[0] — Trace data bit 0.
PIO1_0/ ADC0_6	J3	N3	56	29	[4]	PU	I/O; AI	PIO1_0/ADC0_6 — General-purpose digital input/output pin. ADC input channel 6 if the DIGIMODE bit is set to 0 in the IOCON register for this pin.
							I/O	FC0_RTS_SCL_SSEL1 — Flexcomm 0: USART request-to-send, I2C clock, SPI slave select 1.
							I/O	SD_D[3] — SD/MMC data 3.
							I	CT0_CAP2 — Capture 2 input to Timer 0.
							I	SCT0_GPI4 — Pin input 4 to SCTimer/PWM.
							O	TRACECLK — Trace clock.
PIO1_1	J10	K12	109	55	[2]	PU	I/O	PIO1_1/ — General-purpose digital input/output pin.
							I/O	FC3_RXD_SDA_MOSI — Flexcomm 3: USART receiver, I2C data I/O, SPI master-out/slave-in data.
								R — Reserved.
							I	CT0_CAP3 — Capture 3 input to Timer 0.
							I	SCT0_GPI5 — Pin input 5 to SCTimer/PWM.
								R — Reserved.
								R — Reserved.
							I	USB1_OVERCURRENTN — USB1 bus overcurrent indicator (active low).

Table 4. Pin description ...continued

Symbol	100-pin, TFBGA	180-pin, TFBGA	208-pin, LQFP	100-pin, LQFP		Reset state [1]	Type		Description
PIO1_2	G9	L14	117	58	[2]	PU	I/O		PIO1_2 — General-purpose digital input/output pin.
								O	CAN0_TD — Transmitter output for CAN0.
									R — Reserved.
								O	CT0_MAT3 — Match output 3 from Timer0.
								I	SCT0_GPI6 — Pin input 6 to SCTimer/PWM.
								O	PDM1_CLK — Clock for PDM interface 1, for digital microphone.
									R — Reserved.
O	USB1_PORTPWRN — USB1 VBUS drive indicator (Indicates VBUS must be driven).								
PIO1_3	F10	J13	120	60	[2]	PU	I/O		PIO1_3 — General-purpose digital input/output pin.
								I	CAN0_RD — Receiver input for CAN0.
									R — Reserved.
									R — Reserved.
								O	SCT0_OUT4 — SCTimer/PWM output 4.
								I	PDM1_DATA — Data for PDM interface 1 (digital microphone).
O	USB0_PORTPWRN — USB0 VBUS drive indicator (Indicates VBUS must be driven).								
PIO1_4	C3	D4	3	3	[2]	PU	I/O		PIO1_4 — General-purpose digital input/output pin.
								I/O	FC0_SCK — Flexcomm 0: USART or SPI clock.
								I/O	SD_D[0] — SD/MMC data 0.
								O	CT2_MAT1 — Match output 1 from Timer 2.
								O	SCT0_OUT0 — SCTimer/PWM output 0.
								I	FREQME_GPIO_CLK_A — Frequency Measure pin clock input A.
								I/O	EMC_D[11] — External Memory interface data [11].
PIO1_5	C2	E4	5	4	[2]	PU	I/O		PIO1_5 — General-purpose digital input/output pin.
								I/O	FC0_RXD_SDA_MOSI — Flexcomm 0: USART receiver, I2C data I/O, SPI master-out/slave-in data.
								I/O	SD_D[2] — SD/MMC data 2.
								O	CT2_MAT0 — Match output 0 from Timer 2.
								I	SCT0_GPI0 — Pin input 0 to SCTimer/PWM.
									R — Reserved.
								O	EMC_A[4] — External memory interface address 4.

Table 4. Pin description ...continued

Symbol	100-pin, TFBGA	180-pin, TFBGA	208-pin, LQFP	100-pin, LQFP		Reset state [1]	Type	Description
PIO1_6	F1	G4	30	15	[2]	PU	I/O	PIO1_6 — General-purpose digital input/output pin.
							I/O	FC0_TXD_SCL_MISO — Flexcomm 0: USART transmitter, I2C clock, SPI master-in/slave-out data.
							I/O	SD_D[3] — SD/MMC data 3.
							O	CT2_MAT1 — Match output 1 from Timer 2.
							I	SCT0_GPI3 — Pin input 3 to SCTimer/PWM.
								R — Reserved.
							O	EMC_A[5] — External memory interface address 5.
PIO1_7	H1	N1	38	18	[2]	PU	I/O	PIO1_7 — General-purpose digital input/output pin.
							I/O	FC0_RTS_SCL_SSEL1 — Flexcomm 0: USART request-to-send, I2C clock, SPI slave select 1.
							I/O	SD_D[1] — SD/MMC data 1.
							O	CT2_MAT2 — Match output 2 from Timer 2.
							I	SCT0_GPI4 — Pin input 4 to SCTimer/PWM.
								R — Reserved.
							O	EMC_A[6] — External memory interface address 6.
PIO1_8	H5	P8	72	36	[2]	PU	I/O	PIO1_8 — General-purpose digital input/output pin.
							I/O	FC0_CTS_SDA_SSEL0 — Flexcomm 0: USART clear-to-send, I2C data I/O, SPI Slave Select 0.
							O	SD_CLK — SD/MMC clock.
								R — Reserved.
							O	SCT0_OUT1 — SCTimer/PWM output 1.
							I/O	FC4_SSEL2 — Flexcomm 4: SPI slave select 2.
							O	EMC_A[7] — External memory interface address 7.
PIO1_9	K7	K6	78	39	[2]	PU	I/O	PIO1_9 — General-purpose digital input/output pin.
							O	ENET_TXD0 — Ethernet transmit data 0.
							I/O	FC1_SCK — Flexcomm 1: USART or SPI clock.
							I	CT1_CAP0 — Capture 0 input to Timer 1.
							O	SCT0_OUT2 — SCTimer/PWM output 2.
							I/O	FC4_CTS_SDA_SSEL0 — Flexcomm 4: USART clear-to-send, I2C data I/O, SPI Slave Select 0.
							O	EMC_CASN — External memory interface column access strobe (active low).

Table 4. Pin description ...continued

Symbol	100-pin, TFBGA	180-pin, TFBGA	208-pin, LQFP	100-pin, LQFP		Reset state [1]	Type	Description
PIO1_10	H6	N9	84	41	[2]	PU	I/O	PIO1_10 — General-purpose digital input/output pin.
							O	ENET_TXD1 — Ethernet transmit data 1.
							I/O	FC1_RXD_SDA_MOSI — Flexcomm 1: USART receiver, I2C data I/O, SPI master-out/slave-in data.
							O	CT1_MAT0 — Match output 0 from Timer 1.
							O	SCT0_OUT3 — SCTimer/PWM output 3.
								R — Reserved.
							O	EMC_RASN — External memory interface row address strobe (active low).
PIO1_11	B4	B4	198	94	[2][8]	PU	I/O	PIO1_11 — General-purpose digital input/output pin.
							O	ENET_TX_EN — Ethernet transmit enable (RMII/MII interface).
							I/O	FC1_TXD_SCL_MISO — Flexcomm 1: USART transmitter, I2C clock, SPI master-in/slave-out data.
							I	CT1_CAP1 — Capture 1 input to Timer 1.
							I	USB0_VBUS — Monitors the presence of USB0 bus power.
								R — Reserved.
							O	EMC_CLK[0] — External memory interface clock 0.
PIO1_12	F8	K9	128	62	[2]	PU	I/O	PIO1_12 — General-purpose digital input/output pin.
							I	ENET_RXD0 — Ethernet receive data 0.
							I/O	FC6_SCK — Flexcomm 6: USART, SPI, or I2S clock.
							O	CT1_MAT1 — Match output 1 from Timer 1.
							O	USB0_PORTPWRN — USB0 VBUS drive indicator (Indicates VBUS must be driven).
							O	EMC_DYCSN[0] — External Memory interface SDRAM chip select 0 (active low).
PIO1_13	D10	G10	139	66	[2]	PU	I/O	PIO1_13 — General-purpose digital input/output pin.
							I	ENET_RXD1 — Ethernet receive data 1.
							I/O	FC6_RXD_SDA_MOSI_DATA — Flexcomm 6: USART receiver, I2C data I/O, SPI master-out/slave-in data, I2S data I/O.
							I	CT1_CAP2 — Capture 2 input to Timer 1.
							I	USB0_OVERCURRENTN — USB0 bus overcurrent indicator (active low).
							O	USB0_FRAME — USB0 frame toggle signal.
							O	EMC_DQM[0] — External memory interface data mask 0.

Table 4. Pin description ...continued

Symbol	100-pin, TFBGA	180-pin, TFBGA	208-pin, LQFP	100-pin, LQFP		Reset state [1]	Type	Description
PIO1_14	A9	C12	160	78	[2]	PU	I/O	PIO1_14 — General-purpose digital input/output pin.
							I	ENET_RX_DV — Ethernet receive data valid.
							I	UTICK_CAP2 — Micro-tick timer capture input 2.
							O	CT1_MAT2 — Match output 2 from Timer 1.
							I/O	FC5_CTS_SDA_SSEL0 — Flexcomm 5: USART clear-to-send, I2C data I/O, SPI Slave Select 0.
							O	USB0_LEDN — USB0-configured LED indicator (active low).
							O	EMC_DQM[1] — External memory interface data mask 0.
PIO1_15	C7	A11	176	84	[2]	PU	I/O	PIO1_15 — General-purpose digital input/output pin.
							I	ENET_RX_CLK — Ethernet Receive Clock (MII interface) or Ethernet Reference Clock (RMII interface).
							I	UTICK_CAP3 — Micro-tick timer capture input 3.
							I	CT1_CAP3 — Capture 3 input to Timer 1.
							I/O	FC5_RTS_SCL_SSEL1 — Flexcomm 5: USART request-to-send, I2C clock, SPI slave select 1.
							I/O	FC4_RTS_SCL_SSEL1 — Flexcomm 4: USART request-to-send, I2C clock, SPI slave select 1.
							O	EMC_CKE[0] — External memory interface SDRAM clock enable 0.
PIO1_16	B5	B7	187	88	[2]	PU	I/O	PIO1_16 — General-purpose digital input/output pin.
							O	ENET_MDC — Ethernet management data clock.
							I/O	FC6_TXD_SCL_MISO_WS — Flexcomm 6: USART transmitter, I2C clock, SPI master-in/slave-out data I/O, I2S word-select/frame.
							O	CT1_MAT3 — Match output 3 from Timer 1.
							I/O	SD_CMD — SD/MMC card command I/O.
								R — Reserved.
							O	EMC_A[10] — External memory interface address 10.
PIO1_17	H8	N12	98	47	[2]	PU	I/O	PIO1_17 — General-purpose digital input/output pin.
							I/O	ENET_MDIO — Ethernet management data I/O.
							I/O	FC8_RXD_SDA_MOSI — Flexcomm 8: USART receiver, I2C data I/O, SPI master-out/slave-in data.
								R — Reserved.
							O	SCT0_OUT4 — SCTimer/PWM output 4.
							O	CAN1_TD — Transmitter output for CAN 1.
							O	EMC_BLSN[0] — External memory interface byte lane select 0 (active low).

Table 4. Pin description ...continued

Symbol	100-pin, TFBGA	180-pin, TFBGA	208-pin, LQFP	100-pin, LQFP		Reset state [1]	Type	Description
PIO1_18	D2	D1	15	5	[2]	PU	I/O	PIO1_18 — General-purpose digital input/output pin.
								R — Reserved.
							I/O	FC8_TXD_SCL_MISO — Flexcomm 8: USART transmitter, I2C clock, SPI master-in/slave-out data.
								R — Reserved.
							O	SCT0_OUT5 — SCTimer/PWM output 5.
							I	CAN1_RD — Receiver input for CAN 1.
PIO1_19	F3	L1	33	16	[2]	PU	I/O	PIO1_19 — General-purpose digital input/output pin.
							I/O	FC8_SCK — Flexcomm 8: USART or SPI clock.
							O	SCT0_OUT7 — SCTimer/PWM output 7.
							O	CT3_MAT1 — Match output 1 from Timer 3.
							I	SCT0_GPI7 — Pin input 7 to SCTimer/PWM.
							I/O	FC4_SCK — Flexcomm 4: USART or SPI clock.
PIO1_20	G2	M1	35	17	[2]	PU	I/O	PIO1_20 — General-purpose digital input/output pin.
							I/O	FC7_RTS_SCL_SSEL1 — Flexcomm 7: USART request-to-send, I2C clock, SPI slave select 1.
								R — Reserved.
							I	CT3_CAP2 — Capture 2 input to Timer 3.
								R — Reserved.
							I/O	FC4_TXD_SCL_MISO — Flexcomm 4: USART transmitter, I2C clock, SPI master-in/slave-out data.
PIO1_21	K6	N8	74	37	[2]	PU	I/O	PIO1_21 — General-purpose digital input/output pin.
							I/O	FC7_CTS_SDA_SSEL0 — Flexcomm 7: USART clear-to-send, I2C data I/O, SPI Slave Select 0.
								R — Reserved.
							O	CT3_MAT2 — Match output 2 from Timer 3.
								R — Reserved.
							I/O	FC4_RXD_SDA_MOSI — Flexcomm 4: USART receiver, I2C data I/O, SPI master-out/slave-in data.
	EMC_D[10] — External Memory interface data [10].							

Table 4. Pin description ...continued

Symbol	100-pin, TFBGA	180-pin, TFBGA	208-pin, LQFP	100-pin, LQFP		Reset state [1]	Type		Description
PIO1_22	K8	P11	89	43	[2]	PU	I/O		PIO1_22 — General-purpose digital input/output pin.
									FC8_RTS_SCL_SSEL1 — Flexcomm 8: USART request-to-send, I2C clock, SPI slave select 1.
									SD_CMD — SD/MMC card command I/O.
									CT2_MAT3 — Match output 3 from Timer 2.
									SCT0_GPI5 — Pin input 5 to SCTimer/PWM.
									FC4_SSEL3 — Flexcomm 4: SPI slave select 3.
									EMC_CKE[1] — External memory interface SDRAM clock enable 1.
PIO1_23	K10	M10	97	46	[2]	PU	I/O		PIO1_23 — General-purpose digital input/output pin.
									FC2_SCK — Flexcomm 2: USART or SPI clock.
									SCT0_OUT0 — SCTimer/PWM output 0.
									R — Reserved.
									ENET_MDIO — Ethernet management data I/O.
									FC3_SSEL2 — Flexcomm 3: SPI slave select 2.
									EMC_A[11] — External memory interface address 11.
PIO1_24	G8	N14	111	57	[2]	PU	I/O		PIO1_24 — General-purpose digital input/output pin.
									FC2_RXD_SDA_MOSI — Flexcomm 2: USART receiver, I2C data I/O, SPI master-out/slave-in data.
									SCT0_OUT1 — SCTimer/PWM output 1.
									R — Reserved.
									R — Reserved.
									FC3_SSEL3 — Flexcomm 3: SPI slave select 3.
									EMC_A[12] — External memory interface address 12.
PIO1_25	G10	M12	119	59	[2]	PU	I/O		PIO1_25 — General-purpose digital input/output pin.
									FC2_TXD_SCL_MISO — Flexcomm 2: USART transmitter, I2C clock, SPI master-in/slave-out data.
									SCT0_OUT2 — SCTimer/PWM output 2.
									R — Reserved.
									UTICK_CAP0 — Micro-tick timer capture input 0.
									R — Reserved.
									EMC_A[13] — External memory interface address 13.

Table 4. Pin description ...continued

Symbol	100-pin, TFBGA	180-pin, TFBGA	208-pin, LQFP	100-pin, LQFP		Reset state [1]	Type	Description
PIO1_26	E8	J10	131	63	[2]	PU	I/O	PIO1_26 — General-purpose digital input/output pin.
							I/O	FC2_CTS_SDA_SSEL0 — Flexcomm 2: USART clear-to-send, I2C data I/O, SPI Slave Select 0.
							O	SCT0_OUT3 — SCTimer/PWM output 3.
							I	CT0_CAP3 — Capture 3 input to Timer 0.
							I	UTICK_CAP1 — Micro-tick timer capture input 1.
								R — Reserved.
							O	EMC_A[8] — External memory interface address 8.
PIO1_27	D8	F10	142	68	[2]	PU	I/O	PIO1_27 — General-purpose digital input/output pin.
							I/O	FC2_RTS_SCL_SSEL1 — Flexcomm 2: USART request-to-send, I2C clock, SPI slave select 1.
							I/O	SD_D[4] — SD/MMC data 4.
							O	CT0_MAT3 — Match output 3 from Timer 0.
							O	CLKOUT — Output of the CLKOUT function.
								R — Reserved.
PIO1_28	A10	E12	151	73	[2]	PU	I/O	PIO1_28 — General-purpose digital input/output pin.
							I/O	FC7_SCK — Flexcomm 7: USART, SPI, or I2S clock.
							I/O	SD_D[5] — SD/MMC data 5.
							I	CT0_CAP2 — Capture 2 input to Timer 0.
								R — Reserved.
								R — Reserved.
PIO1_29	A8	C11	165	81	[2][8]	PU	I/O	PIO1_29 — General-purpose digital input/output pin.
							I/O	FC7_RXD_SDA_MOSI_DATA — Flexcomm 7: USART receiver, I2C data I/O, SPI master-out/slave-in data, I2S data I/O.
							I/O	SD_D[6] — SD/MMC data 6.
							I	SCT0_GPI6 — Pin input 6 to SCTimer/PWM.
							O	USB1_PORTPWRN — USB1 VBUS drive indicator (Indicates VBUS must be driven).
							O	USB1_FRAME — USB1 frame toggle signal.
I/O	EMC_D[13] — External Memory interface data [13].							

Table 4. Pin description ...continued

Symbol	100-pin, TFBGA	180-pin, TFBGA	208-pin, LQFP	100-pin, LQFP		Reset state [1]	Type	Description
PIO1_30	C6	A8	182	86	[2]	PU	I/O	PIO1_30 — General-purpose digital input/output pin.
							I/O	FC7_TXD_SCL_MISO_WS — Flexcomm 7: USART transmitter, I2C clock, SPI master-in/slave-out data I/O, I2S word-select/frame.
							I/O	SD_D[7] — SD/MMC data 7.
							I	SCT0_GPI7 — Pin input 7 to SCTimer/PWM.
							I	USB1_OVERCURRENTN — USB1 bus overcurrent indicator (active low).
							O	USB1_LEDN — USB1-configured LED indicator (active low).
							I/O	EMC_D[14] — External Memory interface data [14].
PIO1_31	A3	C5	195	92	[2]	PU	I/O	PIO1_31 — General-purpose digital input/output pin.
							I/O	MCLK — MCLK input or output for I2S and/or digital microphone.
								R — Reserved.
							O	CT0_MAT2 — Match output 2 from Timer 0.
							O	SCT0_OUT6 — SCTimer/PWM output 6.
							I/O	FC8_CTS_SDA_SSEL0 — Flexcomm 8: USART clear-to-send, I2C data I/O, SPI Slave Select 0.
							I/O	EMC_D[15] — External Memory interface data [15].
PIO2_0/ ADC0_7	-	P3	57	-	[4]	PU	I/O; AI	PIO2_0/ADC0_7 — General-purpose digital input/output pin. ADC input channel 7 if the DIGIMODE bit is set to 0 in the IOCON register for this pin.
								R — Reserved.
							I/O	FC0_RXD_SDA_MOSI — Flexcomm 0: USART receiver, I2C data I/O, SPI master-out/slave-in data.
								R — Reserved.
							O	CT1_CAP0 — Capture input 0 to Timer 1.
PIO2_1/ ADC0_8	-	P4	58	-	[4]	PU	I/O; AI	PIO2_1/ADC0_8 — General-purpose digital input/output pin. ADC input channel 8 if the DIGIMODE bit is set to 0 in the IOCON register for this pin.
								R — Reserved.
							I/O	FC0_TXD_SCL_MISO — Flexcomm 0: USART transmitter, I2C clock, SPI master-in/slave-out data.
								R — Reserved.
							O	CT1_MAT0 — Match output 0 from Timer 1.

Table 4. Pin description ...continued

Symbol	100-pin, TFBGA	180-pin, TFBGA	208-pin, LQFP	100-pin, LQFP		Reset state ^[1]	Type	Description
PIO2_2	-	C3	4	-	[2]	PU	I/O	PIO2_2 — General-purpose digital input/output pin.
							I	ENET_CRS — Ethernet Carrier Sense (MII interface) or Ethernet Carrier Sense/Data Valid (RMII interface).
							I/O	FC3_SSEL3 — Flexcomm 3: SPI slave select 3.
							O	SCT0_OUT6 — SCTimer/PWM output 6.
							O	CT1_MAT1 — Match output 1 from Timer 1.
PIO2_3	-	B1	7	-	[2]	PU	I/O	PIO2_3 — General-purpose digital input/output pin.
							O	ENET_TXD2 — Ethernet transmit data 2 (MII interface).
							O	SD_CLK — SD/MMC clock.
							I/O	FC1_RXD_SDA_MOSI — Flexcomm 1: USART receiver, I2C data I/O, SPI master-out/slave-in data.
PIO2_4	-	D3	9	-	[2]	PU	I/O	PIO2_4 — General-purpose digital input/output pin.
							O	ENET_TXD3 — Ethernet transmit data 3 (MII interface).
							I/O	SD_CMD — SD/MMC card command I/O.
							I/O	FC1_TXD_SCL_MISO — Flexcomm 1: USART transmitter, I2C clock, SPI master-in/slave-out data.
							O	CT2_MAT1 — Match output 1 from Timer 2.
PIO2_5	-	C1	12	-	[2]	PU	I/O	PIO2_5 — General-purpose digital input/output pin.
							O	ENET_TX_ER — Ethernet Transmit Error (MII interface).
							O	SD_POW_EN — SD/MMC card power enable
							I/O	FC1_CTS_SDA_SSEL0 — Flexcomm 1: USART clear-to-send, I2C data I/O, SPI Slave Select 0.
PIO2_6	-	F3	17	-	[2]	PU	I/O	PIO2_6 — General-purpose digital input/output pin.
							I	ENET_TX_CLK — Ethernet Transmit Clock (MII interface).
							I/O	SD_D[0] — SD/MMC data 0.
							I/O	FC1_RTS_SCL_SSEL1 — Flexcomm 1: USART request-to-send, I2C clock, SPI slave select 1.
							I	CT0_CAP0 — Capture input 0 to Timer 0.
PIO2_7	-	J2	29	-	[2]	PU	I/O	PIO2_7 — General-purpose digital input/output pin.
							I	ENET_COL — Ethernet Collision detect (MII interface).
							I/O	SD_D(1) — SD/MMC data 1.
							I	FREQME_GPIO_CLK_B — Frequency Measure pin clock input B.
							I	CT0_CAP1 — Capture input 1 to Timer 0.

Table 4. Pin description ...continued

Symbol	100-pin, TFBGA	180-pin, TFBGA	208-pin, LQFP	100-pin, LQFP		Reset state [1]	Type	Description
PIO2_8	-	F4	32	-	[2]	PU	I/O	PIO2_8 — General-purpose digital input/output pin.
							I	ENET_RXD2 — Ethernet Receive Data 2 (MII interface).
							I/O	SD_D[2] — SD/MMC data 2.
								R — Reserved.
							O	CT0_MAT0 — Match output 0 from Timer 0.
PIO2_9	-	K2	36	-	[2]	PU	I/O	PIO2_9 — General-purpose digital input/output pin.
							I	ENET_RXD3 — Ethernet Receive Data 3 (MII interface).
							I/O	SD_D[3] — SD/MMC data 3.
								R — Reserved.
							O	CT0_MAT1 — Match output 0 from Timer 1.
PIO2_10	-	P1	39	-	[2]	PU	I/O	PIO2_10 — General-purpose digital input/output pin.
							I	ENET_RX_ER — Ethernet receive error (RMII/MII interface).
							I	SD_CARD_DET_N — SD/MMC card detect (active low).
PIO2_11	-	K3	43	-	[2]	PU	I/O	PIO2_11 — General-purpose digital input/output pin.
							O	LCD_PWR — LCD panel power enable.
							O	SD_VOLT[0] — SD/MMC card regulator voltage control [0].
								R — Reserved.
								R — Reserved.
							I/O	FC5_SCK — Flexcomm 5: USART or SPI clock.
PIO2_12	-	M2	45	-	[2]	PU	I/O	PIO2_12 — General-purpose digital input/output pin.
							O	LCD_LE — LCD line end signal.
							O	SD_VOLT[1] — SD/MMC card regulator voltage control [1].
							I	USB0_IDVALUE — Indicates to the transceiver whether connected as an A-device (USB0_ID LOW) or B-device (USB0_ID HIGH).
								R — Reserved.
							I/O	FC5_RXD_SDA_MOSI — Flexcomm 5: USART receiver, I2C data I/O, SPI master-out/slave-in data.
PIO2_13	-	P7	70	-	[2]	PU	I/O	PIO2_13 — General-purpose digital input/output pin.
							O	LCD_DCLK — LCD panel clock.
							O	SD_VOLT[2] — SD/MMC card regulator voltage control [2].
								R — Reserved.
								R — Reserved.
							I/O	FC5_TXD_SCL_MISO — Flexcomm 5: USART transmitter, I2C clock, SPI master-in/slave-out data.

Table 4. Pin description ...continued

Symbol	100-pin, TFBGA	180-pin, TFBGA	208-pin, LQFP	100-pin, LQFP		Reset state [1]	Type	Description
PIO2_14	-	L7	77	-	[2][8]	PU	I/O	PIO2_14 — General-purpose digital input/output pin.
							O	LCD_FP — LCD frame pulse (STN). Vertical synchronization pulse (TFT).
							O	USB0_FRAME — USB0 frame toggle signal.
							O	USB0_PORTPWRN — USB0 VBUS drive indicator (Indicates VBUS must be driven).
							O	CT0_MAT2 — Match output 2 from Timer 0.
							I/O	FC5_CTS_SDA_SSEL0 — Flexcomm 5: USART clear-to-send, I2C data I/O, SPI Slave Select 0.
PIO2_15	-	M8	79	-	[2]	PU	I/O	PIO2_15 — General-purpose digital input/output pin.
							O	LCD_AC — LCD STN AC bias drive or TFT data enable output.
							O	USB0_LEDN — USB0-configured LED indicator (active low).
							I	USB0_OVERCURRENTN — USB0 bus overcurrent indicator (active low).
							O	CT0_MAT3 — Match output 3 from Timer 0.
							I/O	FC5_RTS_SCL_SSEL1 — Flexcomm 5: USART request-to-send, I2C clock, SPI slave select 1.
PIO2_16	-	L8	81	-	[2][8]	PU	I/O	PIO2_16 — General-purpose digital input/output pin.
							O	LCD_LP — LCD line synchronization pulse (STN). Horizontal synchronization pulse (TFT).
							O	USB1_FRAME — USB1 frame toggle signal.
							O	USB1_PORTPWRN — USB1 VBUS drive indicator (Indicates VBUS must be driven).
							O	CT1_MAT3 — Match output 3 from Timer 1.
							I/O	FC8_SCK — Flexcomm 8: USART or SPI clock.
PIO2_17	-	P10	86	-	[2]	PU	I/O	PIO2_17 — General-purpose digital input/output pin.
							I	LCD_CLKIN — LCD clock input.
							O	USB1_LEDN — USB1-configured LED indicator (active low).
							I	USB1_OVERCURRENTN — USB1 bus overcurrent indicator (active low).
							I	CT1_CAP1 — Capture 1 input to Timer 1.
							I/O	FC8_RXD_SDA_MOSI — Flexcomm 8: USART receiver, I2C data I/O, SPI master-out/slave-in data.
PIO2_18	-	N10	90	-	[2]	PU	I/O	PIO2_18 — General-purpose digital input/output pin.
							O	LCD_VD[0] — LCD Data [0].
							I/O	FC3_RXD_SDA_MOSI — Flexcomm 3: USART receiver, I2C data I/O, SPI master-out/slave-in data.
							I/O	FC7_SCK — Flexcomm 7: USART, SPI, or I2S clock.
							O	CT3_MAT0 — Match output 0 from Timer 3.

Table 4. Pin description ...continued

Symbol	100-pin, TFBGA	180-pin, TFBGA	208-pin, LQFP	100-pin, LQFP		Reset state [1]	Type	Description
PIO2_19	-	P12	93	-	[2]	PU	I/O	PIO2_19 — General-purpose digital input/output pin.
							O	LCD_VD[1] — LCD Data [1].
							I/O	FC3_TXD_SCL_MISO — Flexcomm 3: USART transmitter, I2C clock, SPI master-in/slave-out data.
							I/O	FC7_RXD_SDA_MOSI_DATA — Flexcomm 7: USART receiver, I2C data I/O, SPI master-out/slave-in data, I2S data I/O.
							O	CT3_MAT1 — Match output 1 from Timer 3.
PIO2_20	-	P13	95	-	[2]	PU	I/O	PIO2_20 — General-purpose digital input/output pin.
							O	LCD_VD[2] — LCD Data [2].
							I/O	FC3_RTS_SCL_SSEL1 — Flexcomm 3: USART request-to-send, I2C clock, SPI slave select 1.
							I/O	FC7_TXD_SCL_MISO_WS — Flexcomm 7: USART transmitter, I2C clock, SPI master-in/slave-out data I/O, I2S word-select/frame.
							O	CT3_MAT2 — Match output 2 from Timer 3.
I	CT4_CAP0 — Capture input 4 to Timer 0.							
PIO2_21	-	L10	99	-	[2]	PU	I/O	PIO2_21 — General-purpose digital input/output pin.
							O	LCD_VD[3] — LCD Data [3].
							I/O	FC3_CTS_SDA_SSEL0 — Flexcomm 3: USART clear-to-send, I2C data I/O, SPI Slave Select 0.
							I/O	MCLK — MCLK input or output for I2S and/or digital microphone.
							O	CT3_MAT3 — Match output 3 from Timer 3.
PIO2_22	-	K10	113	-	[2]	PU	I/O	PIO2_22 — General-purpose digital input/output pin.
							O	LCD_VD[4] — LCD Data [4].
							O	SCT0_OUT7 — SCTimer/PWM output 7.
								R — Reserved.
							I	CT2_CAP0 — Capture input 0 to Timer 2.
PIO2_23	-	M14	115	-	[2]	PU	I/O	PIO2_23 — General-purpose digital input/output pin.
							O	LCD_VD[5] — LCD Data [5].
							O	SCT0_OUT8 — SCTimer/PWM output 8.
PIO2_24	-	K14	118	-	[2]	PU	I/O	PIO2_24 — General-purpose digital input/output pin.
							O	LCD_VD[6] — LCD Data [6].
							O	SCT0_OUT9 — SCTimer/PWM output 9.
PIO2_25	-	J11	121	-	[2][8]	PU	I/O	PIO2_25 — General-purpose digital input/output pin.
							O	LCD_VD[7] — LCD Data [7].
							I	USB0_VBUS — Monitors the presence of USB0 bus power.

Table 4. Pin description ...continued

Symbol	100-pin, TFBGA	180-pin, TFBGA	208-pin, LQFP	100-pin, LQFP		Reset state [1]	Type	Description
PIO2_26	-	H11	124	-	[2]	PU	I/O	PIO2_26 — General-purpose digital input/output pin.
							O	LCD_VD[8] — LCD Data [8].
								R — Reserved.
							I/O	FC3_SCK — Flexcomm 3: USART or SPI clock.
							I	CT2_CAP1 — Capture input 1 to Timer 2.
PIO2_27	-	H14	130	-	[2]	PU	I/O	PIO2_27 — General-purpose digital input/output pin.
							O	LCD_VD[9] — LCD Data [9].
							I/O	FC9_SCK — Flexcomm 9: USART or SPI clock.
							I/O	FC3_SSEL2 — Flexcomm 3: SPI slave select 2.
PIO2_28	-	G13	134	-	[2]	PU	I/O	PIO2_28 — General-purpose digital input/output pin.
							O	LCD_VD[10] — LCD Data [10].
							I/O	FC7_CTS_SDA_SSEL0 — Flexcomm 7: USART clear-to-send, I2C data I/O, SPI Slave Select 0.
								R — Reserved
							I	CT2_CAP2 — Capture input 2 to Timer 2.
PIO2_29	-	G11	137	-	[2]	PU	I/O	PIO2_29 — General-purpose digital input/output pin.
							O	LCD_VD[11] — LCD Data [11].
							I/O	FC7_RTS_SCL_SSEL1 — Flexcomm 7: USART request-to-send, I2C clock, SPI slave select 1.
							I/O	FC8_TXD_SCL_MISO — Flexcomm 8: USART transmitter, I2C clock, SPI master-in/slave-out data.
							I	CT2_CAP3 — Capture 3 input to Timer 2.
							O	CLKOUT — Output of the CLKOUT function.
PIO2_30	-	F12	143	-	[2]	PU	I/O	PIO2_30 — General-purpose digital input/output pin.
							O	LCD_VD[12] — LCD Data [12].
								R — Reserved.
								R — Reserved.
							O	CT2_MAT2 — Match output 2 from Timer 2.
PIO2_31	-	D14	149	-	[2]	PU	I/O	PIO2_31 — General-purpose digital input/output pin.
							O	LCD_VD[13] — LCD Data [13].
PIO3_0	-	D12	155	-	[2]	PU	I/O	PIO3_0 — General-purpose digital input/output pin.
							O	LCD_VD[14] — LCD Data [14].
							O	PDM0_CLK — Clock for PDM interface 0, for digital microphone.
								R — Reserved.
							O	CT1_MAT0 — Match output 0 from Timer 1.

Table 4. Pin description ...continued

Symbol	100-pin, TFBGA	180-pin, TFBGA	208-pin, LQFP	100-pin, LQFP		Reset state ^[1]	Type	Description
PIO3_1	-	D11	159	-	[2]	PU	I/O	PIO3_1 — General-purpose digital input/output pin.
							O	LCD_VD[15] — LCD Data [15].
							I	PDM0_DATA — Data for PDM interface 0 (digital microphone).
								R — Reserved.
							O	CT1_MAT1 — Match output 1 from Timer 1.
PIO3_2	-	C10	164	-	[2]	PU	I/O	PIO3_2 — General-purpose digital input/output pin.
							O	LCD_VD[16] — LCD Data [16].
							I/O	FC9_RXD_SDA_MOSI — Flexcomm 9: USART receiver, I2C data I/O, SPI master-out/slave-in data.
								R — Reserved.
							O	CT1_MAT2 — Match output 2 from Timer 1.
PIO3_3	-	A13	169	-	[2]	PU	I/O	PIO3_3 — General-purpose digital input/output pin.
							O	LCD_VD[17] — LCD Data [17].
							I/O	FC9_TXD_SCL_MISO — Flexcomm 9: USART transmitter, I2C clock, SPI master-in/slave-out data.
PIO3_4	-	B11	172	-	[2]	PU	I/O	PIO3_4 — General-purpose digital input/output pin.
							O	LCD_VD[18] — LCD Data [18].
								R — Reserved.
							I/O	FC8_CTS_SDA_SSEL0 — Flexcomm 8: USART clear-to-send, I2C data I/O, SPI Slave Select 0.
							I	CT4_CAP1 — Capture input 4 to Timer 1.
PIO3_5	-	B10	177	-	[2]	PU	I/O	PIO3_5 — General-purpose digital input/output pin.
							O	LCD_VD[19] — LCD Data [19].
								R — Reserved.
							I/O	FC8_RTS_SCL_SSEL1 — Flexcomm 8: USART request-to-send, I2C clock, SPI slave select 1.
							O	CT4_MAT1 — Match output 1 from Timer 4.
PIO3_6	-	C9	180	-	[2]	PU	I/O	PIO3_6 — General-purpose digital input/output pin.
							O	LCD_VD[20] — LCD Data [20].
							O	LCD_VD[0] — LCD Data [0].
								R — Reserved.
							O	CT4_MAT2 — Match output 2 from Timer 4.
PIO3_7	-	B8	184	-	[2]	PU	I/O	PIO3_7 — General-purpose digital input/output pin.
							O	LCD_VD[21] — LCD Data [21].
							O	LCD_VD[1] — LCD Data [1].
								R — Reserved.
							I	CT4_CAP2 — Capture input 2 to Timer 4.

Table 4. Pin description ...continued

Symbol	100-pin, TFBGA	180-pin, TFBGA	208-pin, LQFP	100-pin, LQFP		Reset state [1]	Type	Description
PIO3_8	-	A7	186	-	[2]	PU	I/O	PIO3_8 — General-purpose digital input/output pin.
							O	LCD_VD[22] — LCD Data [22].
							O	LCD_VD[2] — LCD Data [2].
							R	R — Reserved.
							I	CT4_CAP3 — Capture input 3 to Timer 4.
PIO3_9	-	C7	192	-	[2]	PU	I/O	PIO3_9 — General-purpose digital input/output pin.
							O	LCD_VD[23] — LCD Data [23].
							O	LCD_VD[3] — LCD Data [3].
							R	R — Reserved.
							I	CT0_CAP2 — Capture input 2 to Timer 0.
PIO3_10	-	A3	199	-	[2]		I/O	PIO3_10 — General-purpose digital input/output pin.
							O	SCT0_OUT3 — SCTimer/PWM output 3.
							R	R — Reserved.
							O	CT3_MAT0 — Match output 0 from Timer 3.
							R	R — Reserved.
							R	R — Reserved.
							O	EMC_DYCSN[1] — External Memory interface SDRAM chip select 1(active low).
O	TRACEDATA[0] — Trace data bit 0.							
PIO3_11	-	B2	208	-	[2]	PU	I/O	PIO3_11 — General-purpose digital input/output pin.
							I/O	MCLK — MCLK input or output for I2S and/or digital microphone.
							I/O	FC0_SCK — Flexcomm 0: USART or SPI clock.
							I/O	FC1_SCK — Flexcomm 1: USART or SPI clock.
							R	R — Reserved.
							R	R — Reserved.
							R	R — Reserved.
							O	TRACEDATA[3] — Trace data bit 3.
PIO3_12	-	L2	37	-	[2]	PU	I/O	PIO3_12 — General-purpose digital input/output pin.
							O	SCT0_OUT8 — SCTimer/PWM output 8.
							R	R — Reserved.
							I	CT3_CAP0 — Capture input 0 to Timer 3.
							R	R — Reserved.
							O	CLKOUT — Output of the CLKOUT function.
							O	EMC_CLK[1] — External memory interface clock 1.
O	TRACECLK — Trace clock.							

Table 4. Pin description ...continued

Symbol	100-pin, TFBGA	180-pin, TFBGA	208-pin, LQFP	100-pin, LQFP		Reset state [1]	Type	Description
PIO3_13	-	H4	75	-	[2]	PU	I/O	PIO3_13 — General-purpose digital input/output pin.
							O	SCT0_OUT9 — SCTimer/PWM output 9.
							I/O	FC9_CTS_SDA_SSEL0 — Flexcomm 9: USART clear-to-send, I2C data I/O, SPI Slave Select 0.
							I	CT3_CAP1 — Capture input 1 to Timer 3.
							R	R — Reserved.
							R	R — Reserved.
							I	EMC_FBCK — External memory interface feedback clock.
							O	TRACEDATA[1] — Trace data bit 1.
PIO3_14	-	E3	13	-	[2]	PU	I/O	PIO3_14 — General-purpose digital input/output pin.
							O	SCT0_OUT4 — SCTimer/PWM output 4.
							I/O	FC9_RTS_SCL_SSEL1 — Flexcomm 9: USART request-to-send, I2C clock, SPI slave select 1.
							O	CT3_MAT1 — Match output 1 from Timer 3.
							R	R — Reserved.
							R	R — Reserved.
							R	R — Reserved.
							O	TRACEDATA[2] — Trace data bit 2.
PIO3_15	-	D2	11	-	[2]	PU	I/O	PIO3_15 — General-purpose digital input/output pin.
							I/O	FC8_SCK — Flexcomm 8: USART or SPI clock.
							I	SD_WR_PRT — SD/MMC write protect.
PIO3_16	-	E1	19	-	[2]	PU	I/O	PIO3_16 — General-purpose digital input/output pin.
							I/O	FC8_RXD_SDA_MOSI — Flexcomm 8: USART receiver, I2C data I/O, SPI master-out/slave-in data.
							I/O	SD_D[4] — SD/MMC data 4.
PIO3_17	-	K1	31	-	[2]	PU	I/O	PIO3_17 — General-purpose digital input/output pin.
							I/O	FC8_TXD_SCL_MISO — Flexcomm 8: USART transmitter, I2C clock, SPI master-in/slave-out data.
							I/O	SD_D[5] — SD/MMC data 5.
PIO3_18	-	M6	68	-	[2]	PU	I/O	PIO3_18 — General-purpose digital input/output pin.
							I/O	FC8_CTS_SDA_SSEL0 — Flexcomm 8: USART clear-to-send, I2C data I/O, SPI Slave Select 0.
							I/O	SD_D[6] — SD/MMC data 6.
							O	CT4_MAT0 — Match output 0 from Timer 4.
							O	CAN0_TD — Transmitter output for CAN 0.
O	SCT0_OUT5 — SCTimer/PWM output 5.							

Table 4. Pin description ...continued

Symbol	100-pin, TFBGA	180-pin, TFBGA	208-pin, LQFP	100-pin, LQFP		Reset state [1]	Type	Description
PIO3_19	-	J3	44	-	[2]	PU	I/O	PIO3_19 — General-purpose digital input/output pin.
							I/O	FC8_RTS_SCL_SSEL1 — Flexcomm 8: USART request-to-send, I2C clock, SPI slave select 1.
							I/O	SD_D[7] — SD/MMC data 7.
							O	CT4_MAT1 — Match output 1 from Timer 4.
							I	CAN0_RD — Receiver input for CAN 0.
							O	SCT0_OUT6 — SCTimer/PWM output 6.
PIO3_20	-	N2	46	-	[2]	PU	I/O	PIO3_20 — General-purpose digital input/output pin.
							I/O	FC9_SCK — Flexcomm 9: USART or SPI clock.
							I	SD_CARD_INT_N — Card interrupt line.
							O	CLKOUT — Output of the CLKOUT function.
								R — Reserved.
							O	SCT0_OUT7 — SCTimer/PWM output 7.
PIO3_21/ ADC0_9	-	P5	61	-	[4]	PU	I/O; AI	PIO3_21/ADC0_9 — General-purpose digital input/output pin. ADC input channel 9 if the DIGIMODE bit is set to 0 in the IOCON register for this pin.
							I/O	FC9_RXD_SDA_MOSI — Flexcomm 9: USART receiver, I2C data I/O, SPI master-out/slave-in data.
							O	SD_BACKEND_PWR — SD/MMC back-end power supply for embedded device.
							O	CT4_MAT3 — Match output 3 from Timer 4.
							I	UTICK_CAP2 — Micro-tick timer capture input 2.
PIO3_22/ ADC0_10	-	N5	62	-	[4]	PU	I/O; AI	PIO3_22/ADC0_10 — General-purpose digital input/output pin. ADC input channel 10 if the DIGIMODE bit is set to 0 in the IOCON register for this pin.
							I/O	FC9_TXD_SCL_MISO — Flexcomm 9: USART transmitter, I2C clock, SPI master-in/slave-out data.
PIO3_23	-	C2	8	-	[3]	Z	I/O	PIO3_23 — General-purpose digital input/output pin.
							I/O	FC2_CTS_SDA_SSEL0 — Flexcomm 2: USART clear-to-send, I2C data I/O, SPI Slave Select 0.
								R — Reserved.
							I	UTICK_CAP3 — Micro-tick timer capture input 3.
PIO3_24	-	E2	16	-	[3]	Z	I/O	PIO3_24 — General-purpose digital input/output pin.
							I/O	FC2_RTS_SCL_SSEL1 — Flexcomm 2: USART request-to-send, I2C clock, SPI slave select 1.
							I	CT4_CAP0 — Capture input 4 to Timer 0.
							I	USB0_VBUS — Monitors the presence of USB0 bus power.

Table 4. Pin description ...continued

Symbol	100-pin, TFBGA	180-pin, TFBGA	208-pin, LQFP	100-pin, LQFP		Reset state [1]	Type	Description
PIO3_25	-	P9	82	-	[2]	PU	I/O	PIO3_25 — General-purpose digital input/output pin.
								R — Reserved.
							I	CT4_CAP2 — Capture input 2 to Timer 4.
							I/O	FC4_SCK — Flexcomm 4: USART or SPI clock.
								R — Reserved.
							O	EMC_A[14] — External memory interface address 14.
PIO3_26	-	K5	88	-	[2]	PU	I/O	PIO3_26 — General-purpose digital input/output pin.
								R — Reserved.
							O	SCT0_OUT0 — SCTimer/PWM output 0.
							I/O	FC4_RXD_SDA_MOSI — Flexcomm 4: USART receiver, I2C data I/O, SPI master-out/slave-in data.
								R — Reserved.
								R — Reserved.
PIO3_27	-	P14	96	-	[2]	PU	I/O	PIO3_27 — General-purpose digital input/output pin.
								R — Reserved.
							O	SCT0_OUT1 — SCTimer/PWM output 1.
							I/O	FC4_TXD_SCL_MISO — Flexcomm 4: USART transmitter, I2C clock, SPI master-in/slave-out data.
								R — Reserved.
								R — Reserved.
PIO3_28	-	M11	100	-	[2]	PU	I/O	PIO3_28 — General-purpose digital input/output pin.
								R — Reserved.
							O	SCT0_OUT2 — SCTimer/PWM output 2.
							I/O	FC4_CTS_SDA_SSEL0 — Flexcomm 4: USART clear-to-send, I2C data I/O, SPI Slave Select 0.
								R — Reserved.
								R — Reserved.
	O	EMC_A[17] — External memory interface address 17.						

Table 4. Pin description ...continued

Symbol	100-pin, TFBGA	180-pin, TFBGA	208-pin, LQFP	100-pin, LQFP		Reset state [1]	Type	Description
PIO3_29	-	L13	112	-	[2]	PU	I/O	PIO3_29 — General-purpose digital input/output pin.
								R — Reserved.
							O	SCT0_OUT3 — SCTimer/PWM output 3.
							I/O	FC4_RTS_SCL_SSEL1 — Flexcomm 4: USART request-to-send, I2C clock, SPI slave select 1.
								R — Reserved.
							O	EMC_A[18] — External memory interface address 18.
PIO3_30	-	K13	116	-	[2]	PU	I/O	PIO3_30 — General-purpose digital input/output pin.
							I/O	FC9_CTS_SDA_SSEL0 — Flexcomm 9: USART clear-to-send, I2C data I/O, SPI Slave Select 0.
							O	SCT0_OUT4 — SCTimer/PWM output 4.
							I/O	FC4_SSEL2 — Flexcomm 4: SPI slave select 2.
								R — Reserved.
							O	EMC_A[19] — External memory interface address 19.
PIO3_31	-	J14	123	-	[2]	PU	I/O	PIO3_31 — General-purpose digital input/output pin.
							I/O	FC9_RTS_SCL_SSEL1 — Flexcomm 9: USART request-to-send, I2C clock, SPI slave select 1.
							O	SCT0_OUT5 — SCTimer/PWM output 5.
							O	CT4_MAT2 — Match output 2 from Timer 4.
								R — Reserved.
							I	SCT0_GPI0 — Pin input 0 to SCTimer/PWM.
O	EMC_A[20] — External memory interface address 20.							
PIO4_0	-	H13	127	-	[2]	PU	I/O	PIO4_0 — General-purpose digital input/output pin.
								R — Reserved.
							I/O	FC6_CTS_SDA_SSEL0 — Flexcomm 6: USART clear-to-send, I2C data I/O, SPI Slave Select 0.
							I	CT4_CAP1 — Capture input 4 to Timer 1.
								R — Reserved.
							I	SCT0_GPI1 — Pin input 1 to SCTimer/PWM.
O	EMC_CSN[1] — External memory interface static chip select 1(active low).							

Table 4. Pin description ...continued

Symbol	100-pin, TFBGA	180-pin, TFBGA	208-pin, LQFP	100-pin, LQFP		Reset state [1]	Type	Description
PIO4_1	-	G14	132	-	[2]	PU	I/O	PIO4_1 — General-purpose digital input/output pin.
								R — Reserved.
							I/O	FC6_SCK — Flexcomm 6: USART, SPI, or I2S clock.
								R — Reserved.
								R — Reserved.
							I	SCT0_GPI2 — Pin input 2 to SCTimer/PWM.
PIO4_2	-	F14	138	-	[2]	PU	I/O	PIO4_2 — General-purpose digital input/output pin.
								R — Reserved.
							I/O	FC6_RXD_SDA_MOSI_DATA — Flexcomm 6: USART receiver, I2C data I/O, SPI master-out/slave-in data, I2S data I/O.
								R — Reserved.
								R — Reserved.
							I	SCT0_GPI3 — Pin input 3 to SCTimer/PWM.
PIO4_3	-	F13	140	-	[2]	PU	I/O	PIO4_3 — General-purpose digital input/output pin.
								R — Reserved.
							I/O	FC6_TXD_SCL_MISO_WS — Flexcomm 6: USART transmitter, I2C clock, SPI master-in/slave-out data I/O, I2S word-select/frame.
							I	CT0_CAP3 — Capture 3 input to Timer 0.
								R — Reserved.
							I	SCT0_GPI4 — Pin input 4 to SCTimer/PWM.
PIO4_4	-	D9	147	-	[2]	PU	I/O	PIO4_4 — General-purpose digital input/output pin.
								R — Reserved.
							I/O	FC4_SSEL3 — Flexcomm 4: SPI slave select 3.
							I/O	FC0_RTS_SCL_SSEL1 — Flexcomm 0: USART request-to-send, I2C clock, SPI slave select 1.
								R — Reserved.
							I	SCT0_GPI5 — Pin input 5 to SCTimer/PWM.
	O	EMC_DYCSN[3] — External Memory interface SDRAM chip select 3 (active low).						

Table 4. Pin description ...continued

Symbol	100-pin, TFBGA	180-pin, TFBGA	208-pin, LQFP	100-pin, LQFP		Reset state [1]	Type	Description
PIO4_5	-	E10	154	-	[2]	PU	I/O	PIO4_5 — General-purpose digital input/output pin.
								R — Reserved.
							I/O	FC9_CTS_SDA_SSEL0 — Flexcomm 9: USART clear-to-send, I2C data I/O, SPI Slave Select 0.
							I/O	FC0_CTS_SDA_SSEL0 — Flexcomm 0: USART clear-to-send, I2C data I/O, SPI Slave Select 0.
							O	CT4_MAT3 — Match output 3 from Timer 4.
							I	SCT0_GPI6 — Pin input 6 to SCTimer/PWM.
PIO4_6	-	D10	161	-	[2]	PU	I/O	PIO4_6 — General-purpose digital input/output pin.
								R — Reserved.
							I/O	FC9_RTS_SCL_SSEL1 — Flexcomm 9: USART request-to-send, I2C clock, SPI slave select 1.
								R — Reserved.
								R — Reserved.
							I	SCT0_GPI7 — Pin input 7 to SCTimer/PWM.
PIO4_7	-	A14	166	-	[2][8]	PU	I/O	PIO4_7 — General-purpose digital input/output pin.
								R — Reserved.
							I	CT4_CAP3 — Capture input 3 to Timer 4.
							O	USB0_PORTPWRN — USB0 VBUS drive indicator (Indicates VBUS must be driven).
							O	USB0_FRAME — USB0 frame toggle signal.
PIO4_8	-	B14	170	-	[2]	PU	I/O	PIO4_8 — General-purpose digital input/output pin.
							O	ENET_TXD0 — Ethernet transmit data 0.
							I/O	FC2_SCK — Flexcomm 2: USART or SPI clock.
							I	USB0_OVERCURRENTN — USB0 bus overcurrent indicator (active low).
							O	USB0_LEDN — USB0-configured LED indicator (active low).
							I	SCT0_GPI1 — Pin input 1 to SCTimer/PWM.

Table 4. Pin description ...continued

Symbol	100-pin, TFBGA	180-pin, TFBGA	208-pin, LQFP	100-pin, LQFP		Reset state [1]	Type	Description
PIO4_9	-	A12	173	-	[2][8]	PU	I/O	PIO4_9 — General-purpose digital input/output pin.
							O	ENET_TXD1 — Ethernet transmit data 1.
							I/O	FC2_RXD_SDA_MOSI — Flexcomm 2: USART receiver, I2C data I/O, SPI master-out/slave-in data.
							O	USB1_PORTPWRN — USB1 VBUS drive indicator (Indicates VBUS must be driven).
							O	USB1_FRAME — USB1 frame toggle signal.
							I	SCT0_GPI2 — Pin input 2 to SCTimer/PWM.
PIO4_10	-	B9	181	-	[2]	PU	I/O	PIO4_10 — General-purpose digital input/output pin.
							I	ENET_RX_DV — Ethernet receive data valid.
							I/O	FC2_TXD_SCL_MISO — Flexcomm 2: USART transmitter, I2C clock, SPI master-in/slave-out data.
							I	USB1_OVERCURRENTN — USB1 bus overcurrent indicator (active low).
							O	USB1_LEDN — USB1-configured LED indicator (active low).
								SCT0_GPI3 — Pin input 3 to SCTimer/PWM.
PIO4_11	-	A9	183	-	[2]	PU	I/O	PIO4_11 — General-purpose digital input/output pin.
							I	ENET_RXD0 — Ethernet receive data 0.
							I/O	FC2_CTS_SDA_SSEL0 — Flexcomm 2: USART clear-to-send, I2C data I/O, SPI Slave Select 0.
							I	USB0_IDVALUE — Indicates to the transceiver whether connected as an A-device (USB0_ID LOW) or B-device (USB0_ID HIGH).
								R — Reserved.
							I	SCT0_GPI4 — Pin input 4 to SCTimer/PWM.
PIO4_12	-	A6	188	-	[2]	PU	I/O	PIO4_12 — General-purpose digital input/output pin.
							I	ENET_RXD1 — Ethernet receive data 1.
							I/O	FC2_RTS_SCL_SSEL1 — Flexcomm 2: USART request-to-send, I2C clock, SPI slave select 1.
								R — Reserved.
							I	SCT0_GPI5 — Pin input 5 to SCTimer/PWM.
PIO4_13	-	B6	190	-	[2]	PU	I/O	PIO4_13 — General-purpose digital input/output pin.
							O	ENET_TX_EN — Ethernet transmit enable (RMII/MII interface).
							O	CT4_MAT0 — Match output 0 from Timer 4.
								R — Reserved.
							I	SCT0_GPI6 — Pin input 6 to SCTimer/PWM.

Table 4. Pin description ...continued

Symbol	100-pin, TFBGA	180-pin, TFBGA	208-pin, LQFP	100-pin, LQFP		Reset state [1]	Type	Description
PIO4_14	-	B5	194	-	[2]	PU	I/O	PIO4_14 — General-purpose digital input/output pin.
							I	ENET_RX_CLK — Ethernet Receive Clock (MII interface) or Ethernet Reference Clock (RMII interface).
							O	CT4_MAT1 — Match output 1 from Timer 4.
							I/O	FC9_SCK — Flexcomm 9: USART or SPI clock.
								R — Reserved.
							I	SCT0_GPI7 — Pin input 7 to SCTimer/PWM.
PIO4_15	-	A4	197	-	[2]	PU	I/O	PIO4_15 — General-purpose digital input/output pin.
							O	ENET_MDC — Ethernet management data clock.
							O	CT4_MAT2 — Match output 2 from Timer 4.
							I/O	FC9_RXD_SDA_MOSI — Flexcomm 9: USART receiver, I2C data I/O, SPI master-out/slave-in data.
PIO4_16	-	C4	203	-	[2]	PU	I/O	PIO4_16 — General-purpose digital input/output pin.
							I/O	ENET_MDIO — Ethernet management data I/O.
							O	CT4_MAT3 — Match output 3 from Timer 4.
							I/O	FC9_TXD_SCL_MISO — Flexcomm 9: USART transmitter, I2C clock, SPI master-in/slave-out data.
PIO4_17	-	-	6	-	[2]	PU	I/O	PIO4_17 — General-purpose digital input/output pin.
								R — Reserved.
							O	CAN1_TD — Transmitter output for CAN 1.
							I	CT1_CAP2 — Capture 2 input to Timer 1.
							I	UTICK_CAP0 — Micro-tick timer capture input 0.
								R — Reserved.
PIO4_18	-	-	10	-	[2]	PU	I/O	PIO4_18 — General-purpose digital input/output pin.
								R — Reserved.
							I	CAN1_RD — Receiver input for CAN 1.
							I	CT1_CAP3 — Capture 3 input to Timer 1.
							I	UTICK_CAP1 — Micro-tick timer capture input 1.
								R — Reserved.
							O	EMC_BLSN[3] — External memory interface byte lane select 3 (active low).

Table 4. Pin description ...continued

Symbol	100-pin, TFBGA	180-pin, TFBGA	208-pin, LQFP	100-pin, LQFP		Reset state [1]	Type	Description
PIO4_19	-	-	14	-	[2]	PU	I/O	PIO4_19 — General-purpose digital input/output pin.
							O	ENET_TXD0 — Ethernet transmit data 0.
							O	SD_CLK — SD/MMC clock.
							I/O	FC2_SCK — Flexcomm 2: USART or SPI clock.
							I	CT4_CAP2 — Capture input 2 to Timer 4.
								R — Reserved.
							O	EMC_DQM[2] — External memory interface data mask 2.
PIO4_20	-	-	18	-	[2]	PU	I/O	PIO4_20 — General-purpose digital input/output pin.
							O	ENET_TXD1 — Ethernet transmit data 1.
							I/O	SD_CMD — SD/MMC card command I/O.
							I/O	FC2_RXD_SDA_MOSI — Flexcomm 2: USART receiver, I2C data I/O, SPI master-out/slave-in data.
							I	CT4_CAP3 — Capture input 3 to Timer 4.
								R — Reserved.
							O	EMC_DQM[3] — External memory interface data mask 3.
PIO4_21	-	-	34	-	[2]	PU	I/O	PIO4_21 — General-purpose digital input/output pin.
							O	ENET_TXD2 — Ethernet transmit data 2 (MII interface).
							O	SD_POW_EN — SD/MMC card power enable.
							I/O	FC2_TXD_SCL_MISO — Flexcomm 2: USART transmitter, I2C clock, SPI master-in/slave-out data.
							O	CT2_MAT3 — Match output 3 from Timer 2.
								R — Reserved.
							I/O	EMC_D[16] — External Memory interface data [16].
PIO4_22	-	-	47	-	[2]	PU	I/O	PIO4_22 — General-purpose digital input/output pin.
							O	ENET_TXD3 — Ethernet transmit data 3 (MII interface).
							I	SD_CARD_DET_N — SD/MMC card detect (active low).
							I/O	FC2_RTS_SCL_SSEL1 — Flexcomm 2: USART request-to-send, I2C clock, SPI slave select 1.
							O	CT1_MAT3 — Match output 3 from Timer 1.
								R — Reserved.
							I/O	EMC_D[17] — External Memory interface data [17].

Table 4. Pin description ...continued

Symbol	100-pin, TFBGA	180-pin, TFBGA	208-pin, LQFP	100-pin, LQFP		Reset state [1]	Type	Description
PIO4_23	-	-	42	-	[2]	PU	I/O	PIO4_23 — General-purpose digital input/output pin.
							I	ENET_RXD0 — Ethernet receive data 0.
							I	SD_WR_PRT — SD/MMC write protect.
							I/O	FC2_CTS_SDA_SSEL0 — Flexcomm 2: USART clear-to-send, I2C data I/O, SPI Slave Select 0.
								R — Reserved.
							O	CT1_MAT0 — Match output 0 from Timer 1.
							I/O	EMC_D[18] — External Memory interface data [18].
PIO4_24	-	-	67	-	[2]	PU	I/O	PIO4_24 — General-purpose digital input/output pin.
							I	ENET_RXD1 — Ethernet receive data 1.
							I	SD_CARD_INT_N — Card interrupt line.
							I/O	FC7_RTS_SCL_SSEL1 — Flexcomm 7: USART request-to-send, I2C clock, SPI slave select 1.
								R — Reserved.
							O	CT1_MAT1 — Match output 1 from Timer 1.
							I/O	EMC_D[19] — External Memory interface data [19].
PIO4_25	-	-	69	-	[2]	PU	I/O	PIO4_25 — General-purpose digital input/output pin.
							I	ENET_RXD2 — Ethernet Receive Data 2 (MII interface).
							I/O	SD_D[0] — SD/MMC data 0.
							I/O	FC7_CTS_SDA_SSEL0 — Flexcomm 7: USART clear-to-send, I2C data I/O, SPI Slave Select 0.
								R — Reserved.
							O	CT1_MAT2 — Match output 2 from Timer 1.
							I/O	EMC_D[20] — External Memory interface data [20].
PIO4_26	-	-	73	-	[2]	PU	I/O	PIO4_26 — General-purpose digital input/output pin.
							I	ENET_RXD3 — Ethernet Receive Data 3 (MII interface).
							I/O	SD_D[1] — SD/MMC data 1.
								R — Reserved.
							I	UTICK_CAP2 — Micro-tick timer capture input 2.
							O	CT1_MAT3 — Match output 3 from Timer 1.
							I/O	EMC_D[21] — External Memory interface data [21].

Table 4. Pin description ...continued

Symbol	100-pin, TFBGA	180-pin, TFBGA	208-pin, LQFP	100-pin, LQFP		Reset state [1]	Type	Description
PIO4_27	-	-	85	-	[2]	PU	I/O	PIO4_27 — General-purpose digital input/output pin.
							O	ENET_TX_EN — Ethernet transmit enable (RMII/MII interface).
							I/O	SD_D[2] — SD/MMC data 2.
								R — Reserved.
							I/O	FC1_SCK — Flexcomm 1: USART or SPI clock.
							I	CT1_CAP0 — Capture input 0 to Timer 1.
							I/O	EMC_D[22] — External Memory interface data [22].
PIO4_28	-	-	92	-	[2]	PU	I/O	PIO4_28 — General-purpose digital input/output pin.
							O	ENET_TX_ER — Ethernet Transmit Error (MII interface).
							I/O	SD_D[3] — SD/MMC data 3.
								R — Reserved.
							I/O	FC1_RXD_SDA_MOSI — Flexcomm 1: USART receiver, I2C data I/O, SPI master-out/slave-in data.
							I	CT1_CAP1 — Capture 1 input to Timer 1.
							I/O	EMC_D[23] — External Memory interface data [23].
PIO4_29	-	-	102	-	[2]	PU	I/O	PIO4_29 — General-purpose digital input/output pin.
							I	ENET_RX_ER — Ethernet receive error (RMII/MII interface).
							I/O	SD_D[4] — SD/MMC data 4.
								R — Reserved.
							I/O	FC1_TXD_SCL_MISO — Flexcomm 1: USART transmitter, I2C clock, SPI master-in/slave-out data.
							I	CT1_CAP2 — Capture 2 input to Timer 1.
							I/O	EMC_D[24] — External Memory interface data [24].
PIO4_30	-	-	80	-	[2]	PU	I/O	PIO4_30 — General-purpose digital input/output pin.
							I	ENET_TX_CLK — Ethernet Transmit Clock (MII interface).
							I/O	SD_D[5] — SD/MMC data 5.
							O	CT3_MAT0 — Match output 0 from Timer 3.
							I/O	FC1_RTS_SCL_SSEL1 — Flexcomm 1: USART request-to-send, I2C clock, SPI slave select 1.
							I	CT1_CAP3 — Capture 3 input to Timer 1.
							I/O	EMC_D[25] — External Memory interface data [25].

Table 4. Pin description ...continued

Symbol	100-pin, TFBGA	180-pin, TFBGA	208-pin, LQFP	100-pin, LQFP		Reset state [1]	Type	Description
PIO4_31	-	-	114	-	[2]	PU	I/O	PIO4_31 — General-purpose digital input/output pin.
							I	ENET_RX_CLK — Ethernet Receive Clock (MII interface) or Ethernet Reference Clock (RMII interface).
							I/O	SD_D[6] — SD/MMC data 6.
							O	CT3_MAT1 — Match output 1 from Timer 3.
							I/O	FC4_SCK — Flexcomm 4: USART or SPI clock.
								R — Reserved.
							I/O	EMC_D[26] — External Memory interface data [26].
PIO5_0	-	-	122	-	[2]	PU	I/O	PIO5_0 — General-purpose digital input/output pin.
							I	ENET_RX_DV — Ethernet receive data valid.
							I/O	SD_D[7] — SD/MMC data 7.
							O	CT3_MAT2 — Match output 2 from Timer 3.
							I/O	FC4_RXD_SDA_MOSI — Flexcomm 4: USART receiver, I2C data I/O, SPI master-out/slave-in data.
								R — Reserved.
							I/O	EMC_D[27] — External Memory interface data [27].
PIO5_1	-	-	126	-	[2]	PU	I/O	PIO5_1 — General-purpose digital input/output pin.
							I	ENET_CRIS — Ethernet Carrier Sense (MII interface) or Ethernet Carrier Sense/Data Valid (RMII interface).
							O	SD_VOLT[0] — SD/MMC card regulator voltage control [0].
							O	CT3_MAT3 — Match output 3 from Timer 3.
							I/O	FC4_TXD_SCL_MISO — Flexcomm 4: USART transmitter, I2C clock, SPI master-in/slave-out data.
								R — Reserved.
							I/O	EMC_D[28] — External Memory interface data [28].
PIO5_2	-	-	202	-	[2]	PU	I/O	PIO5_2 — General-purpose digital input/output pin.
							I	ENET_COL — Ethernet Collision detect (MII interface).
							O	SD_VOLT[1] — SD/MMC card regulator voltage control [1].
							I	CT3_CAP0 — Capture input 0 to Timer 3.
							I/O	FC4_CTS_SDA_SSEL0 — Flexcomm 4: USART clear-to-send, I2C data I/O, SPI Slave Select 0.
								R — Reserved.
							I/O	EMC_D[29] — External Memory interface data [29].

Table 4. Pin description ...continued

Symbol	100-pin, TFBGA	180-pin, TFBGA	208-pin, LQFP	100-pin, LQFP		Reset state [1]	Type	Description
PIO5_3	-	-	129	-	[2]	PU	I/O	PIO5_3 — General-purpose digital input/output pin.
							O	ENET_MDC — Ethernet management data clock.
							O	SD_VOLT[2] — SD/MMC card regulator voltage control [2].
							I	CT3_CAP1 — Capture input 1 to Timer 3.
							I/O	FC4_RTS_SCL_SSEL1 — Flexcomm 4: USART request-to-send, I2C clock, SPI slave select 1.
								R — Reserved.
							I/O	EMC_D[30] — External Memory interface data [30].
PIO5_4	-	-	135	-	[2]	PU	I/O	PIO5_4 — General-purpose digital input/output pin.
							I/O	ENET_MDIO — Ethernet management data I/O.
							O	SD_BACKEND_PWR — SD/MMC back-end power supply for embedded device.
							I	CT3_CAP2 — Capture input 2 to Timer 3.
							I/O	FC4_SSEL2 — Flexcomm 4: SPI slave select 2.
								R — Reserved.
PIO5_5	-	-	145	-	[2]	PU	I/O	PIO5_5 — General-purpose digital input/output pin.
							I	SCT0_GPI0 — Pin input 0 to SCTimer/PWM.
							O	PDM1_CLK — Clock for PDM interface 1, for digital microphone.
							I	CT3_CAP3 — Capture input 3 to Timer 3.
							I/O	FC4_SSEL3 — Flexcomm 4: SPI slave select 3.
							O	TRACECLK — Trace clock.
							O	EMC_A[21] — External memory interface address 21.
PIO5_6	-	-	152	-	[2]	PU	I/O	PIO5_6 — General-purpose digital input/output pin.
							I	SCT0_GPI1 — Pin input 1 to SCTimer/PWM.
							I	PDM1_DATA — Data for PDM interface 1 (digital microphone).
							I/O	FC5_SCK — Flexcomm 5: USART or SPI clock.
							O	SCT0_OUT5 — SCTimer/PWM output 5.
							O	TRACEDATA[0] — Trace data bit 0.
							O	EMC_A[22] — External memory interface address 22.

Table 4. Pin description ...continued

Symbol	100-pin, TFBGA	180-pin, TFBGA	208-pin, LQFP	100-pin, LQFP		Reset state [1]	Type	Description
PIO5_7	-	-	171	-	[2]	PU	I/O	PIO5_7 — General-purpose digital input/output pin.
							I	SCT0_GPI2 — Pin input 2 to SCTimer/PWM.
							I/O	MCLK — MCLK input or output for I2S and/or digital microphone.
							I/O	FC5_RXD_SDA_MOSI — Flexcomm 5: USART receiver, I2C data I/O, SPI master-out/slave-in data.
							O	SCT0_OUT6 — SCTimer/PWM output 6.
							O	TRACEDATA[1] — Trace data bit 1.
							O	EMC_A[23] — External memory interface address 23.
PIO5_8	-	-	175	-	[2]	PU	I/O	PIO5_8 — General-purpose digital input/output pin.
							I	SCT0_GPI3 — Pin input 3 to SCTimer/PWM.
							O	PDM0_CLK — Clock for PDM interface 0, for digital microphone.
							I/O	FC5_TXD_SCL_MISO — Flexcomm 5: USART transmitter, I2C clock, SPI master-in/slave-out data.
							O	SCT0_OUT7 — SCTimer/PWM output 7.
							O	TRACEDATA[2] — Trace data bit 2.
PIO5_9	-	-	179	-	[2]	PU	I/O	PIO5_9 — General-purpose digital input/output pin.
							I	SCT0_GPI4 — Pin input 4 to SCTimer/PWM.
							I	PDM0_DATA — Data for PDM interface 0 (digital microphone).
							I/O	FC5_CTS_SDA_SSEL0 — Flexcomm 5: USART clear-to-send, I2C data I/O, SPI Slave Select 0.
							O	SCT0_OUT8 — SCTimer/PWM output 8.
							O	TRACEDATA[3] — Trace data bit 3.
							O	EMC_A[25] — External memory interface address 25.
PIO5_10	-	-	168	-	[2]	PU	I/O	PIO5_10 — General-purpose digital input/output pin.
							I	SCT0_GPI5 — Pin input 5 to SCTimer/PWM.
								R — Reserved.
							I/O	FC5_RTS_SCL_SSEL1 — Flexcomm 5: USART request-to-send, I2C clock, SPI slave select 1.
							O	SCT0_OUT9 — SCTimer/PWM output 9.
I	UTICK_CAP3 — Micro-tick timer capture input 3.							
USB1_AVSSC	D1	F2	20	6			USB1 analog 3.3 V ground.	
USB1_REXT	B1	F1	21	7			USB1 analog signal for reference resistor, 12.4 kΩ +/-1%	
USB1_ID	C1	G1	22	8			Indicates to the transceiver whether connected as an A-device (USB1_ID LOW) or B-device (USB1_ID HIGH).	

Table 4. Pin description ...continued

Symbol	100-pin, TFBGA	180-pin, TFBGA	208-pin, LQFP	100-pin, LQFP		Reset state [1]	Type	Description
USB1_VBUS	D3	G2	23	9	[6][8]		I/O	VBUS pin (power on USB cable). 5 V tolerant when USB1_AVDD3V3 and USB1_AVDDTX3V3 = 0 V.
USB1_AVDDC3V3	E1	G3	24	10				USB1 analog 3.3 V supply.
USB1_AVDDTX3V3	E2	H1	25	11				USB1 analog 3.3 V supply for line drivers.
USB1_DP	F2	H3	27	13	[6]		I/O	USB1 bidirectional D+ line.
USB1_DM	E3	H2	26	12	[6]		I/O	USB1 bidirectional D- line.
USB1_AVSSTX3V3	G1	J1	28	14				USB1 analog ground for line drivers.
USB0_DP	B3	E5	204	97	[6]		I/O	USB0 bidirectional D+ line.
USB0_DM	B2	D5	205	98	[6]		I/O	USB0 bidirectional D- line.
RESETN	J8	N13	101	48	[5]			External reset input: A LOW on this pin resets the device, causing I/O ports and peripherals to take on their default states, and the boot code to execute. Wakes up the part from deep power-down mode.
VDD	D5; D7; E4; E6; F5; F7; G4; G6	E6; E8; F5; G5; J12; L6; L11	1; 48; 65; 104; 108; 156; 157; 206	1; 21; 33; 50; 54; 75; 76; 99		-	-	Single 1.71 V to 3.6 V power supply powers internal digital functions and I/Os.
VSS	D4; D6; E5; E7; F4; F6; G5; G7	B3; D7; D8; E11; H5; J5; K7	2; 49; 66; 103; 107; 148; 162; 201	2; 22; 34; 49; 53; 71; 79; 96		-	-	Ground.
VDDA	J4	N6	64	32		-	-	Analog supply voltage.
VREFN	-	N4	59	-		-	-	ADC negative reference voltage. On TFBGA100 and LQFP100 packages, the ADC negative reference voltage is internally tied to the VSSA pin.
VREFP	K4	P6	63	31		-	-	ADC positive reference voltage.
VSSA	H4	L5	60	30		-	-	Analog ground. On TFBGA100 and LQFP100 packages, the ADC negative reference voltage is internally tied to the VSSA pin.
XTALIN	H2	K4	41	20	[7]	-	-	Main oscillator input.
XTALOUT	G3	J4	40	19	[7]	-	-	Main oscillator output.
VBAT	K9	N11	94	45		-	-	Battery supply voltage. If no battery is used, tie VBAT to VDD or to ground.
RTCXIN	J9	L12	105	51		-	-	RTC oscillator input.
RTCXOUT	H9	K11	106	52		-	-	RTC oscillator output.

- [1] PU = input mode, pull-up enabled (pull-up resistor pulls up pin to V_{DD}). Z = high impedance; pull-up or pull-down disabled, AI = analog input, I = input, O = output, F = floating. Reset state reflects the pin state at reset without boot code operation. For pin states in the different power modes, see [Section 6.2.2 "Pin states in different power modes"](#). For termination on unused pins, see [Section 6.2.1 "Termination of unused pins"](#).
- [2] 5 V tolerant pad with programmable glitch filter (5 V tolerant if V_{DD} present; if V_{DD} not present, do not exceed 3.6 V); provides digital I/O functions with TTL levels and hysteresis; normal drive strength. See [Figure 44](#). Pulse width of spikes or glitches suppressed by input filter is from 3 ns to 16 ns (simulated value).
- [3] True open-drain pin. I2C-bus pins compliant with the I2C-bus specification for I2C standard mode, I2C Fast-mode, and I2C Fast-mode Plus. The pin requires an external pull-up to provide output functionality. When power is switched off, this pin is floating and does not disturb the I2C lines. Open-drain configuration applies to all functions on this pin.
- [4] 5 V tolerant pin providing standard digital I/O functions with configurable modes, configurable hysteresis, and analog input. When configured as an analog input, the digital section of the pin is disabled, and the pin is not 5 V tolerant.
- [5] Reset pad. 5 V tolerant pad with glitch filter with hysteresis. Pulse width of spikes or glitches suppressed by input filter is from 3 ns to 20 ns (simulated value)
- [6] 5 V tolerant transparent analog pad.
- [7] The oscillator input pin (XTALIN) cannot be driven by an external clock. Must connect a crystal between XTALIN and XTALOUT.
- [8] VBUS must be connected to supply voltage when using the USB peripheral.

6.2.1 Termination of unused pins

[Table 5](#) shows how to terminate pins that are **not** used in the application. In many cases, unused pins should be connected externally or configured correctly by software to minimize the overall power consumption of the part.

Unused pins with GPIO function should be configured as outputs set to LOW with their internal pull-up disabled. To configure a GPIO pin as output and drive it LOW, select the GPIO function in the IOCON register, select output in the GPIO DIR register, and write a 0 to the GPIO PORT register for that pin. Disable the pull-up in the pin's IOCON register.

In addition, it is recommended to configure all GPIO pins that are not bonded out on smaller packages as outputs driven LOW with their internal pull-up disabled.

Table 5. Termination of unused pins

Pin	Default state ^[1]	Recommended termination of unused pins
RESET	I; PU	The RESET pin can be left unconnected if the application does not use it.
all PION _m (not open-drain)	I; PU	Can be left unconnected if driven LOW and configured as GPIO output with pull-up disabled by software.
PION _m (I2C open-drain)	IA	Can be left unconnected if driven LOW and configured as GPIO output by software.
RTCXIN	-	Connect to ground. When grounded, the RTC oscillator is disabled.
RTCXOUT	-	Can be left unconnected.
XTALIN	-	Connect to ground. When grounded, the RTC oscillator is disabled.
XTALOUT	-	Can be left unconnected.
VREFP	-	Tie to VDD.
VREFN	-	Tie to VSS.
VDDA	-	Tie to VDD.
VSSA	-	Tie to VSS.
VBAT	-	Tie to VDD.
USB _n _DP	F	Can be left unconnected. If USB interface is not used, pin can be left unconnected except in deep power-down mode where it must be externally pulled low. When the USB PHY is disabled, the pins are floating.

Table 5. Termination of unused pins

Pin	Default state ^[1]	Recommended termination of unused pins
USBn_DM	F	Can be left unconnected. If USB interface is not used, pin can be left unconnected except in deep power-down mode where it must be externally pulled low. When the USB PHY is disabled, the pins are floating.
USB1_AVSCC	F	Tie to VSS.
USB1_VBUS	F	Tie to VDD.
USB1_AVDDC3V3	F	Tie to VDD.
USB1_AVDDTX3V3	F	Tie to VDD.
USB1_AVSSTX3V3	F	Tie to VSS.
USB1_ID	F	Can be left unconnected. If USB interface is not used, pin can be left unconnected.

[1] I = Input, IA = Inactive (no pull-up/pull-down enabled), PU = Pull-Up enabled, F = Floating

6.2.2 Pin states in different power modes

Table 6. Pin states in different power modes

Pin	Active	Sleep	Deep-sleep	Deep power-down ^[2]
PIOn_m pins (not I2C)	As configured in the IOCON ^[1] . Default: internal pull-up enabled.			Floating
PIO0_13 to PIO0_14 (open-drain I2C-bus pins)	As configured in the IOCON ^[1] .			Floating
PIO3_23 to PIO3_24 (open-drain I2C-bus pins)	As configured in the IOCON ^[1] .			Floating
RESET	Reset function enabled. Default: input, internal pull-up enabled. Reset function disabled.			

[1] Default and programmed pin states are retained in sleep and deep-sleep.

[2] If VBAT > VDD, the external reset pin must be floating to prevent high VBAT leakage.

7. Functional description

7.1 Architectural overview

The ARM Cortex-M4 includes three AHB-Lite buses: the system bus, the I-code bus, and the D-code bus. The I-code and D-code core buses allow for concurrent code and data accesses from different slave ports.

The LPC546xx uses a multi-layer AHB matrix to connect the ARM Cortex-M4 buses and other bus masters to peripherals in a flexible manner that optimizes performance by allowing peripherals that are on different slave ports of the matrix to be accessed simultaneously by different bus masters.

7.2 ARM Cortex-M4 processor

The ARM Cortex-M4 is a general purpose, 32-bit microprocessor, which offers high performance and very low power consumption. The ARM Cortex-M4 offers many new features, including a Thumb-2 instruction set, low interrupt latency, hardware multiply and divide, interruptable/continuable multiple load and store instructions, automatic state save and restore for interrupts, tightly integrated interrupt controller with wake-up interrupt controller, and multiple core buses capable of simultaneous accesses.

A 3-stage pipeline is employed so that all parts of the processing and memory systems can operate continuously. Typically, while one instruction is being executed, its successor is being decoded, and a third instruction is being fetched from memory.

7.3 ARM Cortex-M4 integrated Floating Point Unit (FPU)

The FPU fully supports single-precision add, subtract, multiply, divide, multiply and accumulate, and square root operations. It also provides conversions between fixed-point and floating-point data formats, and floating-point constant instructions.

The FPU provides floating-point computation functionality that is compliant with the ANSI/IEEE Std 754-2008, IEEE Standard for Binary Floating-Point Arithmetic, referred to as the IEEE 754 standard.

7.4 Memory Protection Unit (MPU)

The Cortex-M4 includes a Memory Protection Unit (MPU) which can be used to improve the reliability of an embedded system by protecting critical data within the user application.

The MPU allows separating processing tasks by disallowing access to each other's data, disabling access to memory regions, allowing memory regions to be defined as read-only and detecting unexpected memory accesses that could potentially break the system.

The MPU separates the memory into distinct regions and implements protection by preventing disallowed accesses. The MPU supports up to eight regions each of which can be divided into eight subregions. Accesses to memory locations that are not defined in the MPU regions, or not permitted by the region setting, will cause the Memory Management Fault exception to take place.

7.5 Nested Vectored Interrupt Controller (NVIC) for Cortex-M4

The NVIC is an integral part of the Cortex-M4. The tight coupling to the CPU allows for low interrupt latency and efficient processing of late arriving interrupts.

7.5.1 Features

- Controls system exceptions and peripheral interrupts.
- Supports up to 54 vectored interrupts.
- Eight programmable interrupt priority levels, with hardware priority level masking.
- Relocatable vector table.
- Non-Maskable Interrupt (NMI).
- Software interrupt generation.

7.5.2 Interrupt sources

Each peripheral device has one interrupt line connected to the NVIC but may have several interrupt flags.

7.6 System Tick timer (SysTick)

The ARM Cortex-M4 includes a system tick timer (SysTick) that is intended to generate a dedicated SYSTICK exception. The clock source for the SysTick can be the FRO or the Cortex-M4 core clock.

7.7 On-chip static RAM

The LPC546xx support 200 kB SRAM with separate bus master access for higher throughput and individual power control for low-power operation.

7.8 On-chip flash

The LPC546xx supports up to 512 kB of on-chip flash memory.

7.9 On-chip ROM

The 64 kB on-chip ROM contains the boot loader and the following Application Programming Interfaces (API):

- Flash In-Application Programming (IAP) and In-System Programming (ISP).
- ROM-based USB drivers (HID, CDC, MSC, and DFU). Supports flash updates via USB.
- Supports booting from valid user code in flash, USART, SPI, and I2C.
- Legacy, Single, and Dual image boot.
- OTP API for programming OTP memory.
- Random Number Generator (RNG) API.

7.10 EEPROM

The LPC546xx contains up to 16 kB byte of on-chip word-erasable and word-programmable EEPROM data memory. EEPROM is not accessible in deep-sleep and deep-power-down modes.

7.11 Memory mapping

The LPC546xx incorporates several distinct memory regions. The APB peripheral area is 512 kB in size and is divided to allow for up to 32 peripherals. Each peripheral is allocated 4 kB of space simplifying the address decoding. The registers incorporated into the CPU, such as NVIC, SysTick, and sleep mode control, are located on the private peripheral bus.

The ARM Cortex-M4 processor has a single 4 GB address space. The following table shows how this space is used on the LPC546xx.

Table 7. Memory usage and details

Address range	General Use	Address range details and description	
0x0000 0000 to 0x1FFF FFFF	On-chip non-volatile memory	0x0000 0000 - 0x0007 FFFF	Flash memory (512 kB).
	Boot ROM	0x0300 0000 - 0x0300 FFFF	Boot ROM with flash services in a 64 kB space.
	SRAMX	0x0400 0000 - 0x0400 7FFF	I&D SRAM bank (32 kB).
	SPI Flash Interface (SPIFI)	0x1000 0000 - 0x17FF FFFF	SPIFI memory mapped access space (128 MB).
0x2000 0000 to 0x3FFF FFFF	SRAM Banks	0x2000 0000 - 0x2002 7FFF	SRAM banks (160 kB).
	SRAM bit band alias addressing	0x2200 0000 - 0x23FF FFFF	SRAM bit band alias addressing (32 MB)
0x4000 0000 to 0x7FFF FFFF	APB peripherals	0x4000 0000 - 0x4001 FFFF	APB slave group 0 up to 32 peripheral blocks of 4 kB each (128 kB).
		0x4002 0000 - 0x4003 FFFF	APB slave group 1 up to 32 peripheral blocks of 4 kB each (128 kB).
		0x4004 0000 - 0x4005 FFFF	APB asynchronous slave group 2 up to 32 peripheral blocks of 4 kB each (128 kB).
	AHB peripherals	0x4008 0000 - 0x400B FFFF	AHB peripherals (256 kB).
	Peripheral bit band alias addressing	0x4200 0000 - 0x43FF FFFF	Peripheral bit band alias addressing (32 MB)

Table 7. Memory usage and details ...continued

Address range	General Use	Address range details and description	
0x8000 0000 to 0xDFFF FFFF	Off-chip Memory via the External Memory Controller	Four static memory chip selects:	
		0x8000 0000 - 0x83FF FFFF	Static memory chip select 0 (up to 64 MB) ^[1]
		0x8800 0000 - 0x8BFF FFFF	Static memory chip select 1 (up to 64 MB) ^[2]
		0x9000 0000 - 0x93FF FFFF	Static memory chip select 2 (up to 64 MB)
		0x9800 0000 - 0x9BFF FFFF	Static memory chip select 3 (up to 64 MB)
		Four dynamic memory chip selects:	
		0xA000 0000 - 0xA7FF FFFF	Dynamic memory chip select 0 (up to 256MB)
		0xA800 0000 - 0xAFFF FFFF	Dynamic memory chip select 1 (up to 256MB)
		0xB000 0000 - 0xB7FF FFFF	Dynamic memory chip select 2 (up to 256MB)
		0xB800 0000 - 0xBFFF FFFF	Dynamic memory chip select 3 (up to 256MB)
0xE000 0000 to 0xE00F FFFF	Cortex-M4 Private Peripheral Bus	0xE000 0000 - 0xE00F FFFF	Cortex-M4 related functions, includes the NVIC and System Tick Timer.

[1] Can be up to 256 MB, upper address 0x8FFF FFFF, if the address shift mode is enabled. See the EMCSYSCTRL register bit 0 in the *UM10912 LPC546xx user manual*.

[2] Can be up to 128 MB, upper address 0x97FF FFFF, if the address shift mode is enabled. See the EMCSYSCTRL register bit 0 in the *UM10912 LPC546xx user manual*.

[Figure 9](#) shows the overall map of the entire address space from the user program viewpoint following reset.

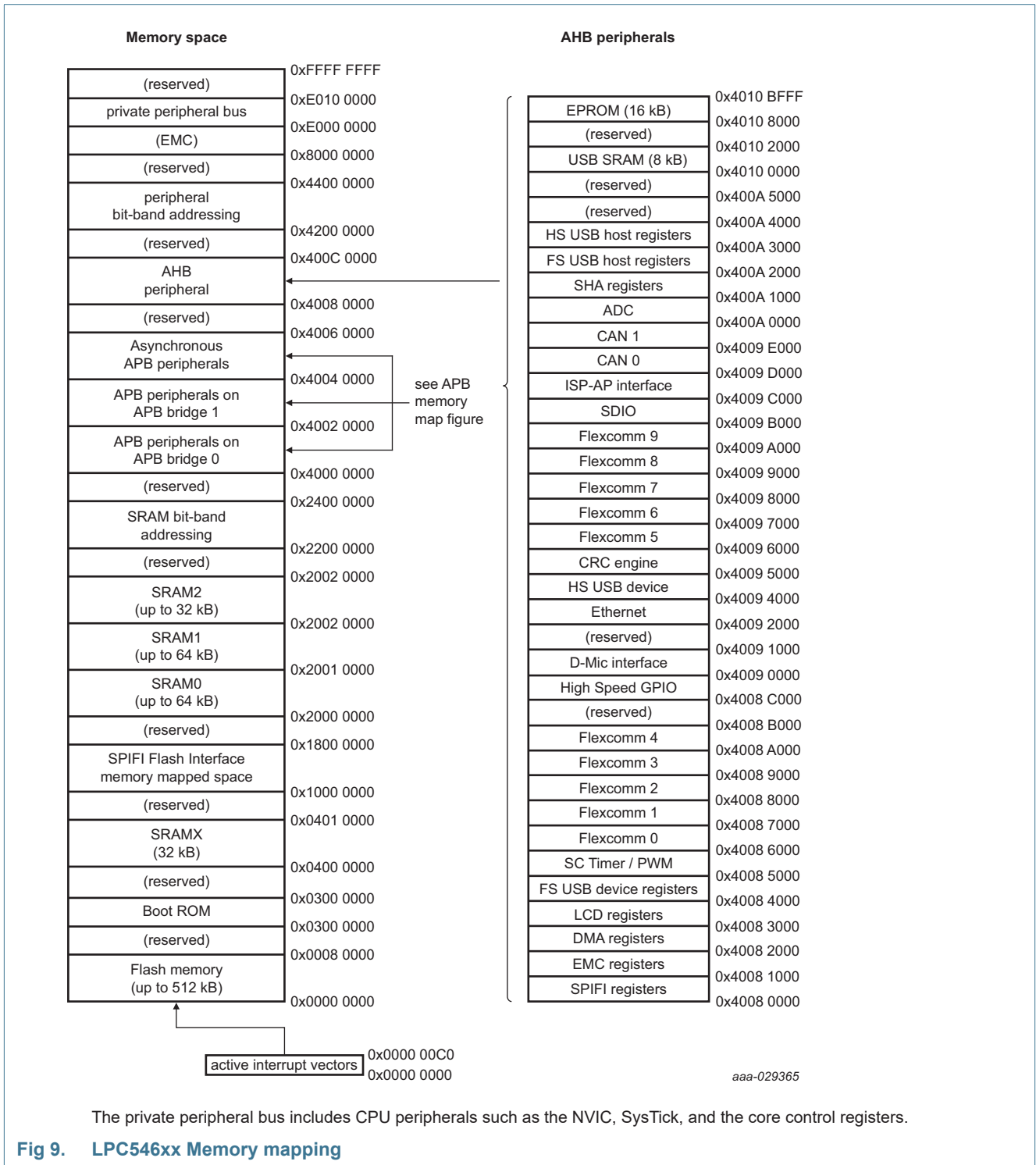

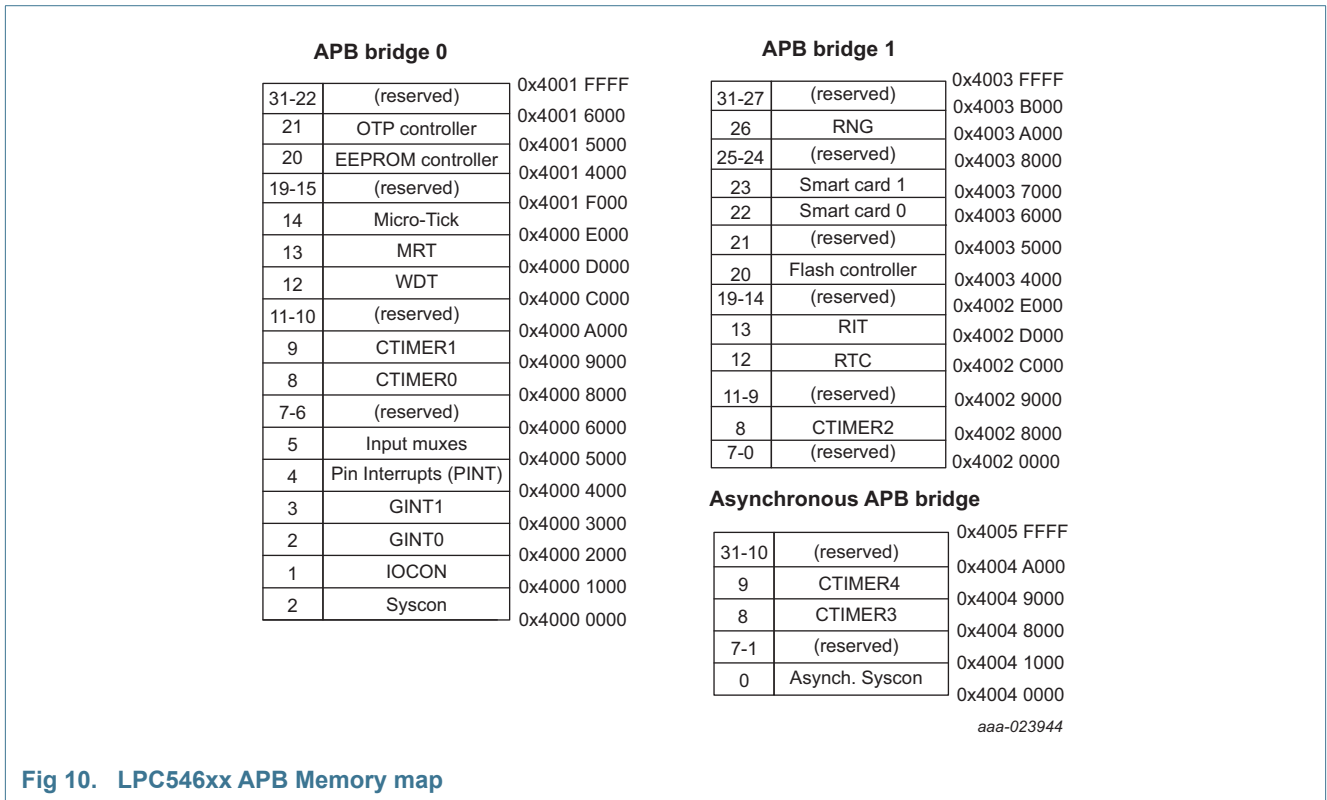

Fig 10. LPC546xx APB Memory map

7.12 System control

7.12.1 Clock sources

The LPC546xx supports one external and two internal clock sources:

- Free Running Oscillator (FRO).
- Watchdog oscillator (WDOSC).
- Crystal oscillator.

7.12.1.1 Free Running Oscillator (FRO)

The FRO 12 MHz oscillator provides the default clock at reset and provides a clean system clock shortly after the supply pins reach operating voltage.

- 12 MHz internal FRO oscillator, factory trimmed for accuracy, that can optionally be used as a system clock as well as other purposes.
- Selectable 48 MHz or 96 MHz FRO oscillator, factory trimmed for accuracy, that can optionally be used as a system clock as well as other purposes.

7.12.1.2 Watchdog oscillator (WDOSC)

The watchdog oscillator is a low-power internal oscillator. The WDOSC can be used to provide a clock to the WWDT and to the entire chip. The low-power watchdog oscillator provides a selectable frequency in the range of 6 kHz to 1.5 MHz. The accuracy of this clock is limited to $\pm 40\%$ over temperature, voltage, and silicon processing variations.

7.12.1.3 Crystal oscillator

The LPC546xx include four independent oscillators. These are the main oscillator, the FRO, the watchdog oscillator, and the RTC oscillator.

Following reset, the LPC546xx will operate from the Internal FRO until switched by software. This allows systems to operate without any external crystal and the boot loader code to operate at a known frequency. See [Figure 11](#) and [Figure 12](#) for an overview of the LPC546xx clock generation.

7.12.2 System PLL (PLL0)

The system PLL accepts an input clock frequency in the range of 32.768 kHz to 25 MHz. The input frequency is multiplied up to a high frequency with a Current Controlled Oscillator (CCO).

The PLL can be enabled or disabled by software.

7.12.3 USB PLL (PLL1)

The USB PLL accepts an input clock frequency in the range of 1 MHz to 25 MHz. The input frequency is multiplied up to a high frequency with a Current Controlled Oscillator (CCO).

The PLL can be enabled or disabled by software.

7.12.4 Audio PLL (PLL2)

The audio PLL accepts an input clock frequency in the range of 1 MHz to 25 MHz. The input frequency is multiplied up to a high frequency with a Current Controlled Oscillator (CCO).

The PLL can be enabled or disabled by software.

7.12.5 Clock Generation

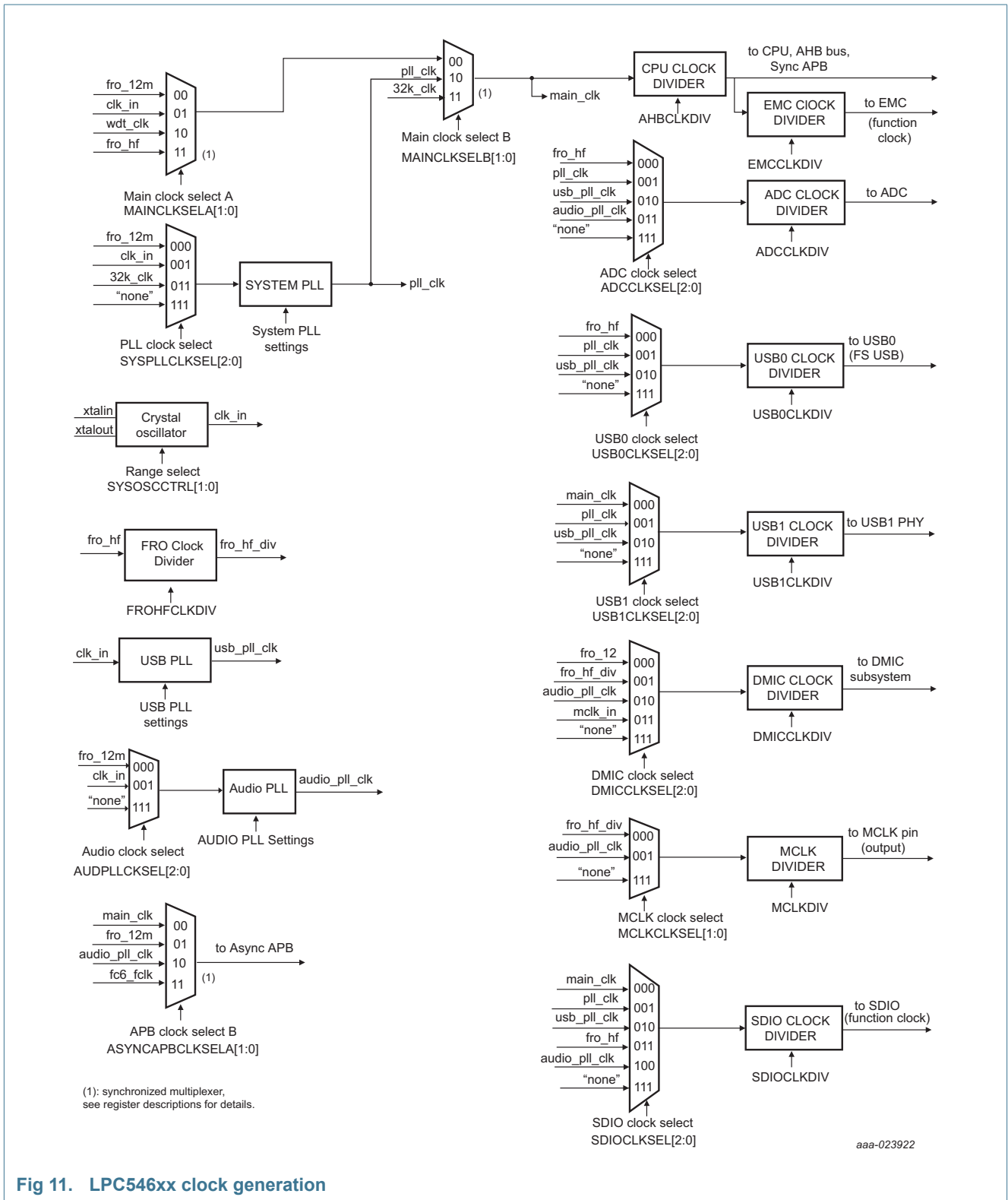

Fig 11. LPC546xx clock generation

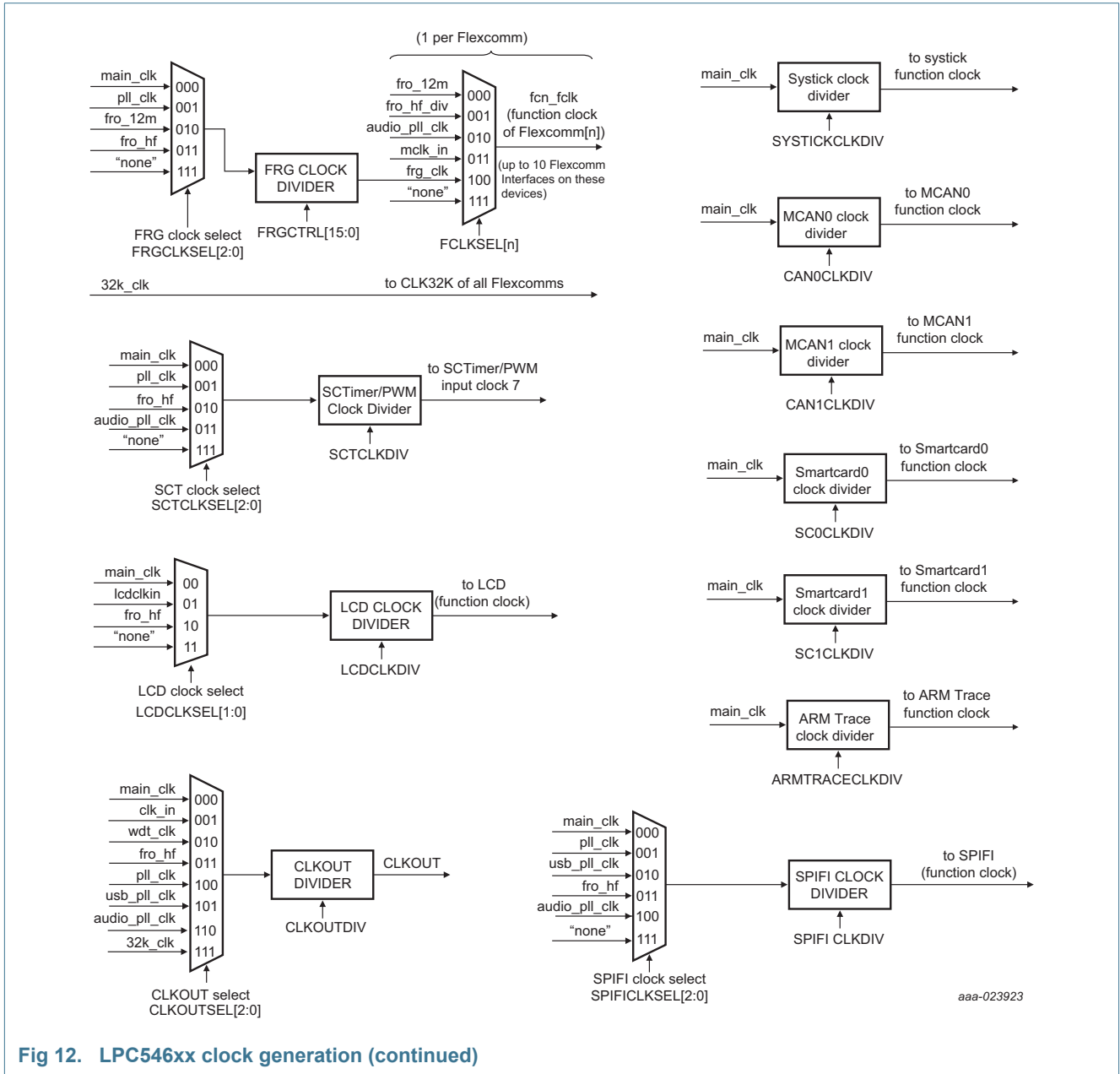

Fig 12. LPC546xx clock generation (continued)

7.12.6 Brownout detection

The LPC546xx includes a monitor for the voltage level on the V_{DD} pin. If this voltage falls below a fixed level, the BOD sets a flag that can be polled or cause an interrupt. In addition, a separate threshold level can be selected to cause chip reset.

7.12.7 Safety

The LPC546xx includes a Windowed WatchDog Timer (WWDT), which can be enabled by software after reset. Once enabled, the WWDT remains locked and cannot be modified in any way until a reset occurs.

7.13 Code security (enhanced Code Read Protection - eCRP)

eCRP is a mechanism that allows the user to enable different features in the security system. The features are specified using a combination of OTP and flash values. Some levels are only controlled by either flash or OTP, but the majority have dual control. The overlap allows higher security by specifying access using OTP bits, which cannot be changed (except to increase security) while allowing customers who are less concerned about security the ability to change levels in the flash image.

eCRP is calculated by reading the ECRP from the flash boot sector (offset 0x0000 0020) and then masking it with the value read from OTP. The OTP bits are more restrictive (that is, disable access) than equivalent values in flash. Certain aspects of eCRP are only specified in the OTP (that is, Mass Erase disable), while others are only specified in flash (that is, Sector Protection count).

For Dual Enhanced images, eCRP is calculated by reading the eCRP from the bootable image sector. The bootable image is defined as the highest revision image that passes the required validation methods.

Remark: If the ECRP is set to the most restrictive combination of OTP and the ECRP of the images, no future factory testing can be performed on the device.

7.14 Power control

The LPC546xx support a variety of power control features. In Active mode, when the chip is running, power and clocks to selected peripherals can be adjusted for power consumption. In addition, there are three special modes of processor power reduction with different peripherals running: sleep mode, deep-sleep mode, and deep power-down mode that can be activated using the power API library from the LPCOpen software package.

7.14.1 Sleep mode

In sleep mode, the system clock to the CPU is stopped and execution of instructions is suspended until either a reset or an interrupt occurs. Peripheral functions, if selected to be clocked can continue operation during Sleep mode and may generate interrupts to cause the processor to resume execution. Sleep mode eliminates dynamic power used by the processor itself, memory systems and related controllers, internal buses, and unused peripherals. The processor state and registers, peripheral registers, and internal SRAM values are maintained, and the logic levels of the pins remain static.

7.14.2 Deep-sleep mode

In deep-sleep mode, the system clock to the processor is disabled as in sleep mode. All analog blocks are powered down by default but can be selected to keep running through the power API if needed as wake-up sources. The main clock and all peripheral clocks are disabled by default. The flash memory is put in standby mode.

Deep-sleep mode eliminates all power used by analog peripherals and all dynamic power used by the processor itself, memory systems and related controllers, and internal buses. The processor state and registers, peripheral registers, and internal SRAM values are maintained, and the logic levels of the pins remain static.

GPIO Pin Interrupts, GPIO Group Interrupts, and selected peripherals such as USB0, USB1, DMIC, SPI, I2C, USART, WWDT, RTC, Micro-tick Timer, and BOD can be left running in deep sleep mode. The FRO, RTC oscillator, and the watchdog oscillator can be left running. In some cases, DMA can operate in deep-sleep mode. For more details, see UM10912, LPC546xx. user manual.

7.14.3 Deep power-down mode

In deep power-down mode, power is shut off to the entire chip except for the RTC power domain and the RESET pin. The LPC546xx can wake up from deep power-down mode via the RESET pin and the RTC alarm. The ALARM1HZ flag in RTC control register generates an RTC wake-up interrupt request, which can wake up the part. During deep power-down mode, the contents of the SRAM and registers are not retained. All functional pins are tri-stated in deep power-down mode.

[Table 8](#) shows the peripheral configuration in reduced power modes.

Table 8. Peripheral configuration in reduced power modes

Peripheral	Reduced power mode		
	Sleep	Deep-sleep	Deep power-down
FRO	Software configured	Software configured	Off
Flash	Software configured	Standby	Off
BOD	Software configured	Software configured	Off
PLL	Software configured	Off	Off
Watchdog osc and WWDT	Software configured	Software configured	Off
Micro-tick Timer	Software configured	Software configured	Off
DMA	Active	Configurable some for operations. For more details, see UM10912, LPC546xx. user manual.	Off
USART	Software configured	Off; but can create a wake-up interrupt in synchronous slave mode or 32 kHz clock mode	Off
SPI	Software configured	Off; but can create a wake-up interrupt in slave mode	Off
I2C	Software configured	Off; but can create a wake-up interrupt in slave mode	Off
USB0	Software configured	Software configured	Off
USB1	Software configured	Software configured	Off
Ethernet	Software configured	Off	Off
DMIC	Software configured	Software configured	Off
Other digital peripherals	Software configured	Off	Off
RTC oscillator	Software configured	Software configured	Software configured

Table 9 shows wake-up sources for reduced power modes.

Table 9. Wake-up sources for reduced power modes

Power mode	Wake-up source	Conditions
Sleep	Any interrupt	Enable interrupt in NVIC.
	HWWAKE	Certain Flexcomm Interface and DMIC subsystem activity.
Deep-sleep	Pin interrupts	Enable pin interrupts in NVIC and STARTER0 and/or STARTER1 registers.
	BOD interrupt	<ul style="list-style-type: none"> • Enable interrupt in NVIC and STARTER0 registers. • Enable interrupt in BODCTRL register. • Configure the BOD to keep running in this mode with the power API.
	BOD reset	Enable reset in BODCTRL register.
	Watchdog interrupt	<ul style="list-style-type: none"> • Enable the watchdog oscillator in the PDRUNCFG0 register. • Enable the watchdog interrupt in NVIC and STARTER0 registers. • Enable the watchdog in the WWDT MOD register and feed. • Enable interrupt in WWDT MOD register. • Configure the WDTOSC to keep running in this mode with the power API.
	Watchdog reset	<ul style="list-style-type: none"> • Enable the watchdog oscillator in the PDRUNCFG0 register. • Enable the watchdog and watchdog reset in the WWDT MOD register and feed.
	Reset pin	Always available.
	RTC 1 Hz alarm timer	<ul style="list-style-type: none"> • Enable the RTC 1 Hz oscillator in the RTCOSCCTRL register. • Enable the RTC bus clock in the AHBCLKCTRL0 register. • Start RTC alarm timer by writing a time-out value to the RTC COUNT register. • Enable the RTCALARM interrupt in the STARTER0 register.
	RTC 1 kHz timer time-out and alarm	<ul style="list-style-type: none"> • Enable the RTC 1 Hz oscillator and the RTC 1 kHz oscillator in the RTC CTRL register. • Start RTC 1 kHz timer by writing a value to the WAKE register of the RTC. • Enable the RTC wake-up interrupt in the STARTER0 register.
	Micro-tick timer (intended for ultra-low power wake-up from deep-sleep mode)	<ul style="list-style-type: none"> • Enable the watchdog oscillator in the PDRUNCFG0 register. • Enable the Micro-tick timer clock by writing to the AHBCLKCTRL1 register. • Start the Micro-tick timer by writing UTICK CTRL register. • Enable the Micro-tick timer interrupt in the STARTER0 register.
	I2C interrupt	Interrupt from I2C in slave mode.
	SPI interrupt	Interrupt from SPI in slave mode.
	USART interrupt	Interrupt from USART in slave or 32 kHz mode.
	USB0 need clock interrupt	Interrupt from USB0 when activity is detected that requires a clock.
	USB1 need clock interrupt	Interrupt from USB1 when activity is detected that requires a clock.
	Ethernet interrupt	Interrupt from ethernet.
DMA interrupt	Interrupt from DMA.	
HWWAKE	Certain Flexcomm Interface and DMIC subsystem activity.	

Table 9. Wake-up sources for reduced power modes

Power mode	Wake-up source	Conditions
Deep power-down	RTC 1 Hz alarm timer	<ul style="list-style-type: none"> • Enable the RTC 1 Hz oscillator in the RTC CTRL register. • Start RTC alarm timer by writing a time-out value to the RTC COUNT register.
	RTC 1 kHz timer time-out and alarm	<ul style="list-style-type: none"> • Enable the RTC 1 Hz oscillator and the RTC 1 kHz oscillator in the RTCSCTRL register. • Enable the RTC bus clock in the AHBCLKCTRL0 register. • Start RTC 1 kHz timer by writing a value to the WAKE register of the RTC.
	Reset pin	Always available.

7.15 General Purpose I/O (GPIO)

The LPC546xx provides six GPIO ports with a total of up to 171 GPIO pins.

Device pins that are not connected to a specific peripheral function are controlled by the GPIO registers. Pins may be dynamically configured as inputs or outputs. Separate registers allow setting or clearing any number of outputs simultaneously. The current level of a port pin can be read back no matter what peripheral is selected for that pin.

7.15.1 Features

- Accelerated GPIO functions:
 - GPIO registers are located on the AHB so that the fastest possible I/O timing can be achieved.
 - Mask registers allow treating sets of port bits as a group, leaving other bits unchanged.
 - All GPIO registers are byte and half-word addressable.
 - Entire port value can be written in one instruction.
- Bit-level set and clear registers allow a single instruction set or clear of any number of bits in one port.
- Direction control of individual bits.
- All I/O default to inputs after reset.
- All GPIO pins can be selected to create an edge or level-sensitive GPIO interrupt request.
- One GPIO group interrupt can be triggered by a combination of any pin or pins.

7.16 Pin interrupt/pattern engine

The pin interrupt block configures up to eight pins from all digital pins for providing eight external interrupts connected to the NVIC. The pattern match engine can be used in conjunction with software to create complex state machines based on pin inputs. Any digital pin, independent of the function selected through the switch matrix can be configured through the SYSCON block as an input to the pin interrupt or pattern match engine. The registers that control the pin interrupt or pattern match engine are located on the I/O+ bus for fast single-cycle access.

7.16.1 Features

- Pin interrupts:
 - Up to eight pins can be selected from all GPIO pins on ports 0 and 1 as edge-sensitive or level-sensitive interrupt requests. Each request creates a separate interrupt in the NVIC.
 - Edge-sensitive interrupt pins can interrupt on rising or falling edges or both.
 - Level-sensitive interrupt pins can be HIGH-active or LOW-active.
 - Level-sensitive interrupt pins can be HIGH-active or LOW-active.
 - Pin interrupts can wake up the device from sleep mode and deep-sleep mode.
- Pattern match engine:
 - Up to eight pins can be selected from all digital pins on ports 0 and 1 to contribute to a boolean expression. The boolean expression consists of specified levels and/or transitions on various combinations of these pins.
 - Each bit slice minterm (product term) comprising of the specified boolean expression can generate its own, dedicated interrupt request.
 - Any occurrence of a pattern match can also be programmed to generate an RXEV notification to the CPU. The RXEV signal can be connected to a pin.
 - Pattern match can be used in conjunction with software to create complex state machines based on pin inputs.
 - Pattern match engine facilitates wake-up only from active and sleep modes.

7.17 Serial peripherals

7.17.1 Full-speed USB Host/Device interface (USB0)

The Universal Serial Bus (USB) is a 4-wire bus that supports communication between a host and one or more (up to 127) peripherals. The host controller allocates the USB bandwidth to attached devices through a token-based protocol. The bus supports hot plugging and dynamic configuration of the devices. All transactions are initiated by the host controller.

7.17.1.1 USB0 device controller

The device controller enables 12 Mbit/s data exchange with a USB host controller. It consists of a register interface, serial interface engine, endpoint buffer memory. The serial interface engine decodes the USB data stream and writes data to the appropriate endpoint buffer. The status of a completed USB transfer or error condition is indicated via status registers. An interrupt is also generated if enabled.

Features

- Supports 10 physical (5 logical) endpoints including two control endpoints.
- Single and double-buffering supported.
- Each non-control endpoint supports bulk, interrupt, or isochronous endpoint types.
- Supports wake-up from reduced power mode on USB activity and remote wake-up.
- Supports SoftConnect.
- Link Power Management (LPM) supported.

7.17.1.2 USB0 host controller

The host controller enables full- and low-speed data exchange with USB devices attached to the bus. It consists of register interface, serial interface engine and DMA controller. The register interface complies with the Open Host Controller Interface (OHCI) specification.

Features

- OHCI compliant.
- Two downstream ports.

7.17.2 High-speed USB Host/Device interface (USB1)

The Universal Serial Bus (USB) is a 4-wire bus that supports communication between a host and one or more (up to 127) peripherals. The host controller allocates the USB bandwidth to attached devices through a token-based protocol. The bus supports hot plugging and dynamic configuration of the devices. All transactions are initiated by the host controller.

7.17.2.1 USB1 device controller

The device controller enables 480 Mbit/s data exchange with a USB host controller. It consists of a register interface, serial interface engine, endpoint buffer memory. The serial interface engine decodes the USB data stream and writes data to the appropriate endpoint buffer. The status of a completed USB transfer or error condition is indicated via status registers. An interrupt is also generated if enabled.

Features

- Fully compliant with *USB 2.0 Specification* (high speed).
- Supports 8 physical (16 logical) endpoints with up to 8 kB endpoint buffer RAM.
- Supports Control, Bulk, Interrupt and Isochronous endpoints.
- Scalable realization of endpoints at run time.
- Endpoint Maximum packet size selection (up to USB maximum specification) by software at run time.
- While USB is in the Suspend mode, the LPC546xx can enter one of the reduced power modes and wake up on USB activity.
- Double buffer implementation for Bulk and Isochronous endpoints.

7.17.2.2 USB1 host controller

The host controller enables high speed data exchange with USB devices attached to the bus. It consists of register interface and serial interface engine. The register interface complies with the Enhanced Host Controller Interface (EHCI) specification.

Features

- EHCI compliant.
- Two downstream ports.
- Supports per-port power switching.

7.17.3 Ethernet AVB

The Ethernet block enables a host to transmit and receive data over Ethernet in compliance with the IEEE 802.3-2008 standard. The Ethernet interface contains a full featured 10 Mbps or 100 Mbps Ethernet MAC (Media Access Controller) designed to provide optimized performance through the use of DMA hardware acceleration.

7.17.3.1 Features

- 10/100 Mbit/s
- DMA support
- Power management remote wake-up frame and magic packet detection
- Supports both full-duplex and half-duplex operation
 - Supports CSMA/CD Protocol for half-duplex operation.
 - Supports IEEE 802.3x flow control for full-duplex operation.
 - Optional forwarding of received pause control frames to the user application in full-duplex operation.
 - Supports IEEE 802.1AS-2011 and 802.1-Qav-2009 for Audio Video (AV) traffic.
 - Software support for AVB feature is available from NXP Professional Services. See nxp.com for more details.
 - Back-pressure support for half-duplex operation.
 - Automatic transmission of zero-quanta pause frame on deassertion of flow control input in full-duplex operation.
- Supports IEEE1588 time stamping and IEEE 1588 advanced time stamping (IEEE 1588-2008 v2).

7.17.4 SPI Flash Interface (SPIFI)

The SPI Flash Interface allows low-cost serial flash memories to be connected to the LPC546xx microcontroller with little performance penalty compared to parallel flash devices with higher pin count.

After a few commands configure the interface at startup, the entire flash content is accessible as normal memory using byte, halfword, and word accesses by the processor and/or DMA channels. Simple sequences of commands handle erasure and programming.

Many serial flash devices use a half-duplex command-driven SPI protocol for device setup and initialization and then move to a half-duplex, command-driven 4-bit protocol for normal operation. Different serial flash vendors and devices accept or require different commands and command formats. SPIFI provides sufficient flexibility to be compatible with common flash devices and includes extensions to help insure compatibility with future devices.

7.17.4.1 Features

- Interfaces to serial flash memory in the main memory map.
- Supports classic and 4-bit bidirectional serial protocols.
- Half-duplex protocol compatible with various vendors and devices.
- Quad SPI Flash Interface with 1-, 2-, or 4-bit data at rates of up to 52 MB per second.

- Supports DMA access.
- Provides XIP (execute in place) feature to execute code directly from serial flash.

7.17.5 CAN Flexible Data (CAN FD) interface

The LPC546xx contains two CAN FD interfaces, CAN FD 1 and CAN FD 2.

7.17.5.1 Features

- Conforms with CAN protocol version 2.0 part A, B and ISO 11898-1.
- CAN FD with up to 64 data bytes supported.
- CAN Error Logging.
- AUTOSAR support.
- SAE J1939 support.
- Improved acceptance filtering.

7.17.6 DMIC subsystem

7.17.6.1 Features

- Pulse-Density Modulation (PDM) data input for left and/or right channels on 1 or 2 buses.
- Flexible decimation.
- 16 entry FIFO for each channel.
- DC blocking or unaltered DC bias can be selected.
- Data can be transferred using DMA from deep-sleep mode without waking up the CPU, then automatically returning to deep-sleep mode.
- Data can be streamed directly to I²S on Flexcomm Interface 7.

7.17.7 Smart card interface

7.17.7.1 Features

- Two DMA supported ISO 7816 Smart Card Interfaces.
- Both asynchronous protocols, T = 0 and T = 1 are supported.

7.17.8 Flexcomm Interface serial communication

7.17.8.1 Features

- USART with asynchronous operation or synchronous master or slave operation.
- SPI master or slave, with up to 4 slave selects.
- I²C, including separate master, slave, and monitor functions.
- Two I2S functions using Flexcomm Interface 6 and Flexcomm Interface 7.
- Data for USART, SPI, and I2S traffic uses the Flexcomm Interface FIFO. The I²C function does not use the FIFO.

7.17.8.2 SPI serial I/O controller

Features

- Maximum data rates of 48 Mbit/s in master mode and 14 Mbit/s in slave mode for SPI functions.
- Data frames of 1 to 16 bits supported directly. Larger frames supported by software or DMA set-up.
- Master and slave operation.
- Data can be transmitted to a slave without the need to read incoming data. This can be useful while setting up an SPI memory.
- Control information can optionally be written along with data. This allows very versatile operation, including “any length” frames.
- Four Slave Select input/outputs with selectable polarity and flexible usage.
- Activity on the SPI in slave mode allows wake-up from deep-sleep mode on any enabled interrupt.

Remark: Texas Instruments SSI and National Microwire modes are not supported.

7.17.8.3 I²C-bus interface

The I²C-bus is bidirectional for inter-IC control using only two wires: a serial clock line (SCL) and a serial data line (SDA). Each device is recognized by a unique address and can operate as either a receiver-only device (for example, an LCD driver) or a transmitter with the capability to both receive and send information (such as memory). Transmitters and/or receivers can operate in either master or slave mode, depending on whether the chip has to initiate a data transfer or is only addressed. The I²C is a multi-master bus and can be controlled by more than one bus master connected to it.

Features

- All I2Cs support standard, Fast-mode, and Fast-mode Plus with data rates of up to 1 Mbit/s.
- All I2Cs support high-speed slave mode with data rates of up to 3.4 Mbit/s.
- Independent Master, Slave, and Monitor functions.
- Supports both Multi-master and Multi-master with Slave functions.
- Multiple I²C slave addresses supported in hardware.
- One slave address can be selectively qualified with a bit mask or an address range in order to respond to multiple I²C-bus addresses.
- 10-bit addressing supported with software assist.
- Supports SMBus.
- Activity on the I2C in slave mode allows wake-up from deep-sleep mode on any enabled interrupt.

7.17.8.4 USART

Features

- Maximum bit rates of 6.25 Mbit/s in asynchronous mode.
- The maximum supported bit rate for USART master synchronous mode is 24 Mbit/s, and the maximum supported bit rate for USART slave synchronous mode is 12.5 Mbit/s.
- 7, 8, or 9 data bits and 1 or 2 stop bits.
- Synchronous mode with master or slave operation. Includes data phase selection and continuous clock option.
- Multiprocessor/multidrop (9-bit) mode with software address compare.
- RS-485 transceiver output enable.
- Autobaud mode for automatic baud rate detection
- Parity generation and checking: odd, even, or none.
- Software selectable oversampling from 5 to 16 clocks in asynchronous mode.
- One transmit and one receive data buffer.
- RTS/CTS for hardware signaling for automatic flow control. Software flow control can be performed using Delta CTS detect, Transmit Disable control, and any GPIO as an RTS output.
- Received data and status can optionally be read from a single register
- Break generation and detection.
- Receive data is 2 of 3 sample "voting". Status flag set when one sample differs.
- Built-in Baud Rate Generator with auto-baud function.
- A fractional rate divider is shared among all USARTs.
- Interrupts available for Receiver Ready, Transmitter Ready, Receiver Idle, change in receiver break detect, Framing error, Parity error, Overrun, Underrun, Delta CTS detect, and receiver sample noise detected.
- Loopback mode for testing of data and flow control.
- In synchronous slave mode, wakes up the part from deep-sleep mode.
- Special operating mode allows operation at up to 9600 baud using the 32.768 kHz RTC oscillator as the UART clock. This mode can be used while the device is in deep-sleep mode and can wake-up the device when a character is received.
- USART transmit and receive functions work with the system DMA controller.

7.17.8.5 I²S-bus interface

The I²S bus provides a standard communication interface for streaming data transfer applications such as digital audio or data collection. The I²S bus specification defines a 3-wire serial bus, having one data, one clock, and one word select/frame trigger signal, providing single or dual (mono or stereo) audio data transfer as well as other configurations. In the LPC546xx, the I²S function is included in Flexcomm Interface 6 and Flexcomm Interface 7. Each of the Flexcomm Interface implements four I²S channel pairs.

The I²S interface within one Flexcomm Interface provides at least one channel pair that can be configured as a master or a slave. Other channel pairs, if present, always operate as slaves. All of the channel pairs within one Flexcomm Interface share one set of I²S

signals, and are configured together for either transmit or receive operation, using the same mode, same data configuration and frame configuration. All such channel pairs can participate in a time division multiplexing (TDM) arrangement. For cases requiring an MCLK input and/or output, this is handled outside of the I²S block in the system level clocking scheme.

Features

- A Flexcomm Interface may implement one or more I²S channel pairs, the first of which could be a master or a slave, and the rest of which would be slaves. All channel pairs are configured together for either transmit or receive and other shared attributes. The number of channel pairs is defined for each Flexcomm Interface, and may be from 0 to 4.
- Configurable data size for all channels within one Flexcomm Interface, from 4 bits to 32 bits. Each channel pair can also be configured independently to act as a single channel (mono as opposed to stereo operation).
- All channel pairs within one Flexcomm Interface share a single bit clock (SCK) and word select/frame trigger (WS), and data line (SDA).
- Data for all I²S traffic within one Flexcomm Interface uses the Flexcomm Interface FIFO. The FIFO depth is 8 entries.
- Left justified and right justified data modes.
- DMA support using FIFO level triggering.
- TDM (Time Division Multiplexing) with a several stereo slots and/or mono slots is supported. Each channel pair can act as any data slot. Multiple channel pairs can participate as different slots on one TDM data line.
- The bit clock and WS can be selectively inverted.
- Sampling frequencies supported depends on the specific device configuration and applications constraints (for example, system clock frequency and PLL availability.) but generally supports standard audio data rates. See the data rates section in I²S chapter in the LPC546xx. user manual to calculate clock and sample rates.

Remark: The Flexcomm Interface function clock frequency should not be above 48 MHz.

7.18 Digital peripheral

7.18.1 LCD controller

The LCD controller provides all of the necessary control signals to interface directly to various color and monochrome LCD panels. Both STN (single and dual panel) and TFT panels can be operated. The display resolution is selectable and can be up to 1024 × 768 pixels. Several color modes are provided, up to a 24-bit true-color non-palettized mode. An on-chip 512 byte color palette allows reducing bus utilization (that is, memory size of the displayed data) while still supporting many colors.

The LCD interface includes its own DMA controller to allow it to operate independently of the CPU and other system functions. A built-in FIFO acts as a buffer for display data, providing flexibility for system timing. Hardware cursor support can further reduce the amount of CPU time required to operate the display.

7.18.1.1 Features

- AHB master interface to access frame buffer.
- Setup and control via a separate AHB slave interface.
- Dual 16-deep programmable 64-bit wide FIFOs for buffering incoming display data.
- Supports single and dual-panel monochrome Super Twisted Nematic (STN) displays with 4-bit or 8-bit interfaces.
- Supports single and dual-panel color STN displays.
- Supports Thin Film Transistor (TFT) color displays.
- Programmable display resolution including, but not limited to: 320 × 200, 320 × 240, 640 × 200, 640 × 240, 640 × 480, 800 × 600, and 1024 × 768.
- Hardware cursor support for single-panel displays.
- 15 gray-level monochrome, 3375 color STN, and 32 K color palettized TFT support.
- 1, 2, or 4 bits-per-pixel (bpp) palettized displays for monochrome STN.
- 1, 2, 4, or 8 bpp palettized color displays for color STN and TFT.
- 16 bpp true-color non-palettized for color STN and TFT.
- 24 bpp true-color non-palettized for color TFT.
- Programmable timing for different display panels.
- 256 entry, 16-bit palette RAM, arranged as a 128 × 32-bit RAM.
- Frame, line, and pixel clock signals.
- AC bias signal for STN, data enable signal for TFT panels.
- Supports little and big-endian, and Windows CE data formats.
- LCD panel clock may be generated from the peripheral clock, or from a clock input pin.

7.18.2 SD/MMC card interface

The SD/MMC card interface supports the following modes to control:

7.18.2.1 Features

- Secure Digital memory (SD version 1.1).
- Secure Digital I/O (SDIO version 2.0).
- Consumer Electronics Advanced Transport Architecture (CE-ATA version 1.1).
- MultiMedia Cards (MMC version 4.1).
- Supports up to a maximum of 50 MHz of interface frequency.

7.18.3 External memory controller

The LPC546xx EMC is an ARM PrimeCell MultiPort Memory Controller peripheral offering support for asynchronous static memory devices such as RAM, ROM, and flash. In addition, it can be used as an interface with off-chip memory-mapped devices and peripherals. The EMC is an Advanced Microcontroller Bus Architecture (AMBA) compliant peripheral.

7.18.3.1 Features

- Read and write buffers to reduce latency and to improve performance.
- Low transaction latency.
- Asynchronous static memory device support including RAM, ROM, and flash, with or without asynchronous page mode.
- 8/16/32 data and 16/20/26 address lines wide static memory support.
- Static memory features include:
 - Asynchronous page mode read.
 - Programmable Wait States.
 - Bus turnaround delay.
 - Output enable and write enable delays.
 - Extended wait.
- Dynamic memory interface support including single data rate SDRAM.
- 16 bit and 32 bit wide chip select SDRAM memory support.
- EMC bus width (bit) on LQFP100 and TFBGA100 packages supports up to 8/16 data line wide static memory, in addition to dynamic memories, such as, SDRAM (2 banks only) with an SDRAM clock of up to 100 MHz.
- Four chip selects for synchronous memory and four chip selects for static memory devices.
- Power-saving modes dynamically control EMC_CKE and EMC_CLK outputs to SDRAMs.
- Dynamic memory self-refresh mode controlled by software.
- Controller supports 2048 (A0 to A10), 4096 (A0 to A11), and 8192 (A0 to A12) row address synchronous memory parts. That is typical 512 MB, 256 MB, and 128 MB parts, with 4, 8, 16, or 32 data bits per device.
- Separate reset domains allow the for auto-refresh through a chip reset if desired.

Note: Synchronous static memory devices (synchronous burst mode) are not supported.

7.18.4 DMA controller

The DMA controller allows peripheral-to memory, memory-to-peripheral, and memory-to-memory transactions. Each DMA stream provides unidirectional DMA transfers for a single source and destination.

7.18.4.1 Features

- One channel per on-chip peripheral direction: typically one for input and one for output for most peripherals.
- DMA operations can optionally be triggered by on- or off-chip events.
- Priority is user selectable for each channel.
- Continuous priority arbitration.
- Address cache.
- Efficient use of data bus.
- Supports single transfers up to 1,024 words.
- Address increment options allow packing and/or unpacking data.

7.19 Counter/timers

7.19.1 General-purpose 32-bit timers/external event counter

The LPC546xx includes five general-purpose 32-bit timer/counters.

The timer/counter is designed to count cycles of the system derived clock or an externally-supplied clock. It can optionally generate interrupts, generate timed DMA requests, or perform other actions at specified timer values, based on four match registers. Each timer/counter also includes two capture inputs to trap the timer value when an input signal transitions, optionally generating an interrupt.

7.19.1.1 Features

- A 32-bit timer/counter with a programmable 32-bit prescaler.
- Counter or timer operation.
- Up to four 32-bit captures can take a snapshot of the timer value when an input signal transitions. A capture event may also optionally generate an interrupt. The number of capture inputs for each timer that are actually available on device pins may vary by device.
- Four 32-bit match registers that allow:
 - Continuous operation with optional interrupt generation on match.
 - Stop timer on match with optional interrupt generation.
 - Reset timer on match with optional interrupt generation.
 - Shadow registers are added for glitch-free PWM output.
- For each timer, up to four external outputs corresponding to match registers with the following capabilities (the number of match outputs for each timer that are actually available on device pins may vary by device):
 - Set LOW on match.
 - Set HIGH on match.

- Toggle on match.
- Do nothing on match.
- Up to two match registers can be used to generate timed DMA requests.
- The timer and prescaler may be configured to be cleared on a designated capture event. This feature permits easy pulse width measurement by clearing the timer on the leading edge of an input pulse and capturing the timer value on the trailing edge.
- Up to four match registers can be configured for PWM operation, allowing up to three single edged controlled PWM outputs. (The number of match outputs for each timer that are actually available on device pins may vary by device.)

7.19.2 SCTimer/PWM

The SCTimer/PWM allows a wide variety of timing, counting, output modulation, and input capture operations. The inputs and outputs of the SCTimer/PWM are shared with the capture and match inputs/outputs of the 32-bit general-purpose counter/timers.

The SCTimer/PWM can be configured as two 16-bit counters or a unified 32-bit counter. In the two-counter case, in addition to the counter value the following operational elements are independent for each half:

- State variable.
- Limit, halt, stop, and start conditions.
- Values of Match/Capture registers, plus reload or capture control values.

In the two-counter case, the following operational elements are global to the SCTimer/PWM, but the last three can use match conditions from either counter:

- Clock selection
- Inputs
- Events
- Outputs
- Interrupts

7.19.2.1 Features

- Two 16-bit counters or one 32-bit counter.
- Counter(s) clocked by bus clock or selected input.
- Up counter(s) or up-down counter(s).
- State variable allows sequencing across multiple counter cycles.
- Event combines input or output condition and/or counter match in a specified state.
- Events control outputs, interrupts, and the SCTimer/PWM states.
 - Match register 0 can be used as an automatic limit.
 - In bi-directional mode, events can be enabled based on the count direction.
 - Match events can be held until another qualifying event occurs.
- Selected event(s) can limit, halt, start, or stop a counter.
- Supports:

- 8 inputs
- 10 outputs
- 10 match/capture registers
- 10 events
- 10 states
- PWM capabilities including dead time and emergency abort functions

7.19.3 Windowed WatchDog Timer (WWDT)

The purpose of the watchdog is to reset the controller if software fails to periodically service it within a programmable time window.

7.19.3.1 Features

- Internally resets chip if not periodically reloaded during the programmable time-out period.
- Optional windowed operation requires reload to occur between a minimum and maximum time period, both programmable.
- Optional warning interrupt can be generated at a programmable time prior to watchdog time-out.
- Enabled by software but requires a hardware reset or a watchdog reset/interrupt to be disabled.
- Incorrect feed sequence causes reset or interrupt if enabled.
- Flag to indicate watchdog reset.
- Programmable 24-bit timer with internal prescaler.
- Selectable time period from $(T_{cy(WDCLK)} \times 256 \times 4)$ to $(T_{cy(WDCLK)} \times 2^{24} \times 4)$ in multiples of $T_{cy(WDCLK)} \times 4$.
- The Watchdog Clock (WDCLK) uses the WDOSC as the clock source.

7.19.4 Real Time Clock (RTC) timer

The RTC timer is a 32-bit timer which counts down from a preset value to zero. At zero, the preset value is reloaded and the counter continues. The RTC timer uses the 32.768 kHz clock input to create a 1 Hz or 1 kHz clock.

7.19.5 Multi-Rate Timer (MRT)

The Multi-Rate Timer (MRT) provides a repetitive interrupt timer with four channels. Each channel can be programmed with an independent time interval, and each channel operates independently from the other channels.

7.19.5.1 Features

- 24-bit interrupt timer.
- Four channels independently counting down from individually set values.
- Repeat and one-shot interrupt modes.

7.19.6 Repetitive Interrupt Timer (RIT)

The repetitive interrupt timer provides a free-running 48-bit counter which is compared to a selectable value, generating an interrupt when a match occurs. Any bits of the timer/compare can be masked such that they do not contribute to the match detection. The repetitive interrupt timer can be used to create an interrupt that repeats at predetermined intervals.

7.19.6.1 Features

- 48-bit counter running from the main clock. Counter can be free-running or can be reset when an RIT interrupt is generated.
- 48-bit compare value.
- 48-bit compare mask. An interrupt is generated when the counter value equals the compare value, after masking. This allows for combinations not possible with a simple compare.
- Can be used for ETM debug time stamping.

7.20 12-bit Analog-to-Digital Converter (ADC)

The ADC supports a resolution of 12-bit and fast conversion rates of up to 5 Msamples/s. Sequences of analog-to-digital conversions can be triggered by multiple sources. Possible trigger sources are the SCTimer/PWM, external pins, and the ARM TXEV interrupt.

The ADC supports a variable clocking scheme with clocking synchronous to the system clock or independent, asynchronous clocking for high-speed conversions

The ADC includes a hardware threshold compare function with zero-crossing detection. The threshold crossing interrupt is connected internally to the SCTimer/PWM inputs for tight timing control between the ADC and the SCTimer/PWM.

7.20.1 Features

- 12-bit successive approximation analog to digital converter.
- Input multiplexing among up to 12 pins.
- Two configurable conversion sequences with independent triggers.
- Optional automatic high/low threshold comparison and “zero crossing” detection.
- Measurement range VREFN to VREFP (typically 3 V; not to exceed VDDA voltage level).
- 12-bit conversion rate of 5.0 Msamples/s. Options for reduced resolution at higher conversion rates.
- Burst conversion mode for single or multiple inputs.
- Synchronous or asynchronous operation. Asynchronous operation maximizes flexibility in choosing the ADC clock frequency, Synchronous mode minimizes trigger latency and can eliminate uncertainty and jitter in response to a trigger.

7.21 CRC engine

The Cyclic Redundancy Check (CRC) generator with programmable polynomial settings supports several CRC standards commonly used. To save system power and bus bandwidth, the CRC engine supports DMA transfers.

7.21.1 Features

- Supports three common polynomials CRC-CCITT, CRC-16, and CRC-32.
 - CRC-CCITT: $x^{16} + x^{12} + x^5 + 1$
 - CRC-16: $x^{16} + x^{15} + x^2 + 1$
 - CRC-32: $x^{32} + x^{26} + x^{23} + x^{22} + x^{16} + x^{12} + x^{11} + x^{10} + x^8 + x^7 + x^5 + x^4 + x^2 + x + 1$
- Bit order reverse and 1's complement programmable setting for input data and CRC sum.
- Programmable seed number setting.
- Supports CPU PIO or DMA back-to-back transfer.
- Accept any size of data width per write: 8, 16 or 32-bit.
 - 8-bit write: 1-cycle operation.
 - 16-bit write: 2-cycle operation (8-bit x 2-cycle).
 - 32-bit write: 4-cycle operation (8-bit x 4-cycle).

7.22 Temperature sensor

The temperature sensor transducer uses an intrinsic pn-junction diode reference and outputs a CTAT voltage (Complement To Absolute Temperature). The output voltage varies inversely with device temperature with an absolute accuracy of better than ± 5 °C over the full temperature range (-40 °C to $+105$ °C). The temperature sensor is only approximately linear with a slight curvature. The output voltage is measured over different ranges of temperatures and fit with linear-least-square lines.

After power-up, the temperature sensor output must be allowed to settle to its stable value before it can be used as an accurate ADC input.

For an accurate measurement of the temperature sensor by the ADC, the ADC must be configured in single-channel burst mode. The last value of a nine-conversion (or more) burst provides an accurate result.

7.23 Security features

The OTP memory contains a memory bank of 128 bits each. OTP bank contains 4 words: word 0 for ECRP, word 1 is reserved, words 2 and 3 can be used by user application for storing application specific options.

7.23.1 Features

- OTP memory.
- Random number generator (RNG).

7.23.2 SHA-1 and SHA-2

The Hash peripheral is used to perform SHA-1 and SHA-2 (256) based hashing. A hash takes an arbitrarily large message or image and forms a relatively small fixed size “unique” number called a digest. The data is fed by words from the processor, DMA, or hosted access; the words are converted from little-endian (ARM standard) to big-endian (SHA standard) by the block.

7.23.2.1 Features

- Used with an HMAC to support a challenge/response or to validate a message.
- Can be used to verify external memory that has not been compromised.

7.24 Code security (enhanced Code Read Protection - eCRP)

eCRP is a mechanism that allows the user to enable different features in the security system. The features are specified using a combination of OTP and flash values. Some levels are only controlled by either flash or OTP, but the majority have dual control. The overlap allows higher security by specifying access using OTP bits, which cannot be changed (except to increase security) while allowing customers who are less concerned about security the ability to change levels in the flash image.

eCRP is calculated by reading the ECRP from the flash boot sector (offset 0x0000 0020) and then masking it with the value read from OTP. The OTP bits are more restrictive (that is, disable access) than equivalent values in flash. Certain aspects of eCRP are only specified in the OTP (that is, Mass Erase disable), while others are only specified in flash (that is, Sector Protection count).

For Dual Enhanced images, eCRP is calculated by reading the eCRP from the bootable image sector. The bootable image is defined as the highest revision image that passes the required validation methods.

7.25 Emulation and debugging

Debug and trace functions are integrated into the ARM Cortex-M4. Serial wire debug and trace functions are supported. The ARM Cortex-M4 is configured to support up to eight breakpoints and four watch points.

The ARM SYSREQ reset is supported and causes the processor to reset the peripherals, execute the boot code, restart from address 0x0000 0000, and break at the user entry point.

The SWD pins are multiplexed with other digital I/O pins. On reset, the pins assume the SWD functions by default.

8. Limiting values

Table 10. Limiting values

In accordance with the Absolute Maximum Rating System (IEC 60134).^[1]

Symbol	Parameter	Conditions		Min	Max	Unit
V _{DD}	supply voltage (core and external rail)	on pin VDD	[2]	-0.5	+4.6	V
V _{DDA}	analog supply voltage	on pin VDDA		-0.5	+4.6	V
V _{BAT}	battery supply voltage	on pin VBAT		-0.5	+4.6	V
V _{ref}	reference voltage	on pin VREFP	-	-0.5	+4.6	V
V _I	input voltage	only valid when the V _{DD} > 1.8 V; 5 V tolerant I/O pins	[6][7]	-0.5	+5.0	V
		on I2C open-drain pins	[5]	-0.5	+5.0	V
		USB_DM, USB_DP pins		-0.5	+5.0	V
V _{IA}	analog input voltage	on digital pins configured for an analog function	[8][9]	-0.5	VDD	V
I _{DD}	supply current	per supply pin, 1.71 V ≤ V _{DD} < 2.7 V	[3]	-	200	mA
	supply current	per supply pin, 2.7 V ≤ V _{DD} < 3.6 V	[3]	-	300	mA
I _{SS}	ground current	per ground pin, 1.71 V ≤ V _{DD} < 2.7 V	[3]	-	200	mA
	ground current	per ground pin, 2.7 V ≤ V _{DD} < 3.6 V	[3]	-	300	mA
I _{latch}	I/O latch-up current	-(0.5V _{DD}) < V _I < (1.5V _{DD}); T _j < 125 °C		-	100	mA
T _{stg}	storage temperature		[10]	-65	+150	°C
T _{j(max)}	maximum junction temperature			-	+150	°C

Table 10. Limiting values ...continuedIn accordance with the Absolute Maximum Rating System (IEC 60134).^[1]

Symbol	Parameter	Conditions		Min	Max	Unit
P _{tot(pack)}	total power dissipation (per package)	LQFP208, based on package heat transfer, not device power consumption	[11]	-	1.2	W
		LQFP208, based on package heat transfer, not device power consumption	[12]	-	0.95	W
		LQFP100, based on package heat transfer, not device power consumption	[11]	-	0.82	W
		LQFP100, based on package heat transfer, not device power consumption	[12]	-	0.60	W
		TFBGA180, based on package heat transfer, not device power consumption	[11]	-	0.95	W
		TFBGA180, based on package heat transfer, not device power consumption	[13]	-	1.2	W
		TFBGA100, based on package heat transfer, not device power consumption	[11]	-	0.57	W
		TFBGA100, based on package heat transfer, not device power consumption	[13]	-	0.65	W
V _{ESD}	electrostatic discharge voltage	human body model; all pins	[4]	-	2000	V

[1] The following applies to the limiting values:

- a) This product includes circuitry specifically designed for the protection of its internal devices from the damaging effects of excessive static charge. Nonetheless, it is suggested that conventional precautions be taken to avoid applying greater than the rated maximum.
 - b) Parameters are valid over operating temperature range unless otherwise specified. All voltages are with respect to V_{SS} unless otherwise noted.
 - c) The limiting values are stress ratings only and operating the part at these values is not recommended and proper operation is not guaranteed. The conditions for functional operation are specified in [Table 21](#).
- [2] Maximum/minimum voltage above the maximum operating voltage (see [Table 21](#)) and below ground that can be applied for a short time (< 10 ms) to a device without leading to irrecoverable failure. Failure includes the loss of reliability and shorter lifetime of the device.
- [3] The peak current is limited to 25 times the corresponding maximum current.
- [4] Human body model: equivalent to discharging a 100 pF capacitor through a 1.5 kΩ series resistor.
- [5] V_{DD} present or not present. Compliant with the I²C-bus standard. 5.5 V can be applied to this pin when V_{DD} is powered down.
- [6] Applies to all 5 V tolerant I/O pins except true open-drain pins.
- [7] Including the voltage on outputs in 3-state mode.
- [8] An ADC input voltage above 3.6 V can be applied for a short time without leading to immediate, unrecoverable failure. Accumulated exposure to elevated voltages at 4.6 V must be less than 10⁶ s total over the lifetime of the device. Applying an elevated voltage to the ADC inputs for a long time affects the reliability of the device and reduces its lifetime.

- [9] It is recommended to connect an overvoltage protection diode between the analog input pin and the voltage supply pin.
- [10] Dependent on package type.
- [11] JEDEC (4.5 in × 4 in); still air.
- [12] Single layer (4.5 in × 3 in); still air.
- [13] 8-layer (4.5 in × 3 in); still air.

9. Thermal characteristics

The average chip junction temperature, T_j (°C), can be calculated using the following equation:

$$T_j = T_{amb} + (P_D \times R_{th(j-a)}) \quad (1)$$

- T_{amb} = ambient temperature (°C),
- $R_{th(j-a)}$ = the package junction-to-ambient thermal resistance (°C/W)
- P_D = sum of internal and I/O power dissipation

The internal power dissipation is the product of I_{DD} and V_{DD} . The I/O power dissipation of the I/O pins is often small and many times can be negligible. However it can be significant in some applications.

Table 11. Thermal resistance

Symbol	Parameter	Conditions	Max/Min	Unit
LQFP208 Package				
$R_{th(j-a)}$	thermal resistance from junction to ambient	JEDEC (4.5 in × 4 in); still air	33 ± 15 %	°C/W
		Single-layer (4.5 in × 3 in); still air	41 ± 15 %	°C/W
$R_{th(j-c)}$	thermal resistance from junction to case		16 ± 15 %	°C/W
LQFP100 Package				
$R_{th(j-a)}$	thermal resistance from junction to ambient	JEDEC (4.5 in × 4 in); still air	48 ± 15 %	°C/W
		Single-layer (4.5 in × 3 in); still air	65 ± 15 %	°C/W
$R_{th(j-c)}$	thermal resistance from junction to case		19 ± 15 %	°C/W
TFBGA180 Package				
$R_{th(j-a)}$	thermal resistance from junction to ambient	JEDEC (4.5 in × 4 in); still air	41 ± 15 %	°C/W
		8-layer (4.5 in × 3 in); still air	33 ± 15 %	°C/W
$R_{th(j-c)}$	thermal resistance from junction to case		14 ± 15 %	°C/W
TFBGA100 Package				
$R_{th(j-a)}$	thermal resistance from junction to ambient	JEDEC (4.5 in × 4 in); still air	69 ± 15 %	°C/W
		8-layer (4.5 in × 3 in); still air	60 ± 15 %	°C/W
$R_{th(j-c)}$	thermal resistance from junction to case		10 ± 15 %	°C/W

10. Static characteristics

10.1 General operating conditions

Table 12. General operating conditions

$T_{amb} = -40\text{ }^{\circ}\text{C}$ to $+105\text{ }^{\circ}\text{C}$, unless otherwise specified.

Symbol	Parameter	Conditions	Min	Typ ^[1]	Max	Unit	
f_{clk}	CPU clock frequency		[3]	-	220	MHz	
	CPU clock frequency	For USB high-speed device and host operations	[3]	60	220	MHz	
	CPU clock frequency	For USB full-speed device and host operations	[3]	12	220	MHz	
		For OTP programming only		-	12	MHz	
V_{DD}	supply voltage (core and external rail)			1.71	-	3.6	V
		For OTP programming only	[2]	2.7	-	3.6	V
		For USB full-speed operation only		3.0	-	3.6	V
		For USB high-speed operation only		1.71	-	3.6	V
V_{DDA}	analog supply voltage		1.71	-	3.6	V	
V_{BAT}	battery supply voltage		1.71	-	3.6	V	
V_{refp}	ADC positive reference voltage	$V_{DDA} \geq 2\text{ V}$		2.0	-	V_{DDA}	V
		$V_{DDA} < 2\text{ V}$		V_{DDA}	-	V_{DDA}	V
USB1_AVDD3V3, USB1_AVDDTX3V3	USB1 analog supply		3.0	3.3	3.6	V	
T_{amb}	Temperature	For EEPROM operation	-40.0	-	+85	$^{\circ}\text{C}$	
RTC oscillator pins							
$V_{i(rtc)}$	32.768 kHz oscillator input voltage	on pin RTCXIN	-0.5	-	+3.6	V	
$V_{o(rtc)}$	32.768 kHz oscillator output voltage	on pin RTCXOUT	-0.5	-	+3.6	V	
$V_{i(xtal)}$	crystal input voltage	on pin XTALIN	-0.5	-	1.95	V	
$V_{o(xtal)}$	crystal output voltage	on pin XTALOUT	-0.5	-	1.95	V	

[1] Typical ratings are not guaranteed. The values listed are for room temperature (25 $^{\circ}\text{C}$), nominal supply voltages.

[2] Attempting to program below 2.7 V will result in unpredictable results and the part might enter an unrecoverable state.

[3] The LPC5460x/61x operates at CPU frequencies of up to 180 MHz. The LPC54628 operates at CPU frequencies of up to 220 MHz.

10.2 Power-up ramp conditions

Table 13. Power-up characteristics^[1]

$T_{amb} = -40\text{ }^{\circ}\text{C}$ to $+105\text{ }^{\circ}\text{C}$.

Symbol	Parameter		Min	Typ	Max	Unit
t_{wd}	Window duration (time where $V_1 < V_{DD} < V_2$)		-	-	170	μs
V_1	Window low voltage	[2]	1.4	-	-	V
V_2	Window high voltage	[3]	-	-	1.62	V

[1] Assert the external reset pin until V_{DD} is $> 1.62\text{ V}$ if the power-up characteristic specification cannot be implemented.

[2] V_{DD} to stay above V_1 for the entire duration t_{wd} .

[3] V_{DD} to stay below V_2 for the minimum duration of t_{wd} .

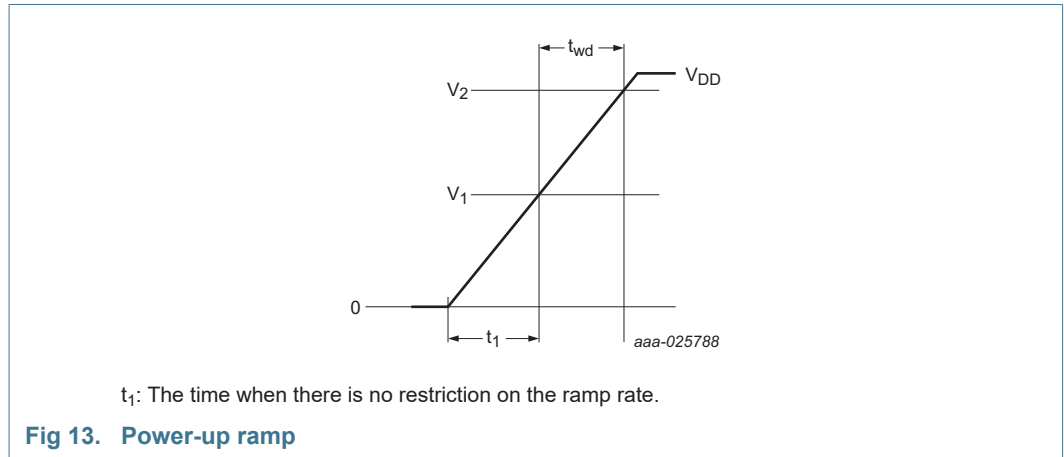

10.3 CoreMark data

Table 14. CoreMark score^[1]

$T_{amb} = 25\text{ }^{\circ}\text{C}$, $V_{DD} = 3.3\text{ V}$

Parameter	Conditions		Typ	Unit
ARM Cortex-M4 in active mode				
CoreMark score	CoreMark code executed from SRAMX; CCLK = 12 MHz	[2][4][5][7][8]	3.38	Iterations/s/MHz
	CCLK = 96 MHz	[2][4][5][7][8]	3.38	Iterations/s/MHz
	CCLK = 180 MHz	[3][4][5][7][8]	3.38	Iterations/s/MHz
	CCLK = 220 MHz	[3][4][5][7][8]	3.38	Iterations/s/MHz
CoreMark score	CoreMark code executed from flash; CCLK = 12 MHz; 1 system clock flash access time.	[2][4][5][6][8]	3.38	Iterations/s/MHz
	CCLK = 96 MHz; 5 system clock flash access time.	[2][4][5][6][8]	2.59	Iterations/s/MHz
	CCLK = 180 MHz; 9 system clock flash access time.	[3][4][5][6][8]	1.99	Iterations/s/MHz
	CCLK = 220 MHz; 8 system clock flash access time.	[3][4][5][6][8][9]	2.11	Iterations/s/MHz
	CCLK = 220 MHz; 9 system clock flash access time.	[3][4][5][6][8]	1.99	Iterations/s/MHz

- [1] Based on the power API library from the SDK software package available on nxp.com.
- [2] Clock source FRO. PLL disabled.
- [3] Clock source 12 MHz FRO. PLL enabled.
- [4] Characterized through bench measurements using typical samples.
- [5] Compiler settings: IAR C/C++ Compiler for Arm ver 8.22.2, optimization level 3, optimized for time on.
- [6] See the FLASHCFG register in the LPC546xx. User Manual for system clock flash access time settings. Acceleration enable bit in the FLASHCFG register is set to 1.
- [7] Flash is powered down
- [8] SRAM1, SRAM2, SRAM3, and USB SRAM powered down. SRAM0 and SRAMX powered.
- [9] At 220 MHz the minimum system clock/access time can be lower when compared to 180 MHz because the power library optimizes the on-chip voltage regulator.

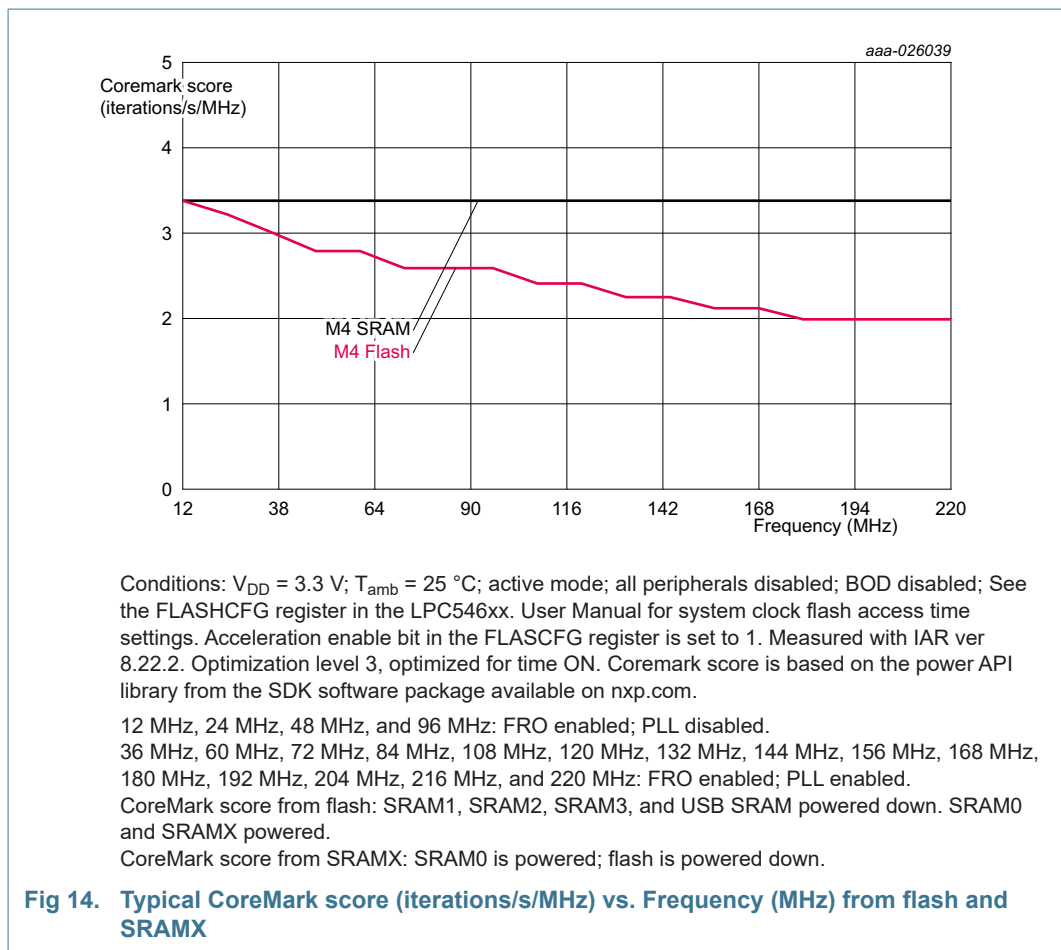

10.4 Power consumption

Power measurements in Active, sleep, and deep-sleep modes were performed under the following conditions:

- Configure all pins as GPIO with pull-up resistor disabled in the IOCON block.
- Configure GPIO pins as outputs using the GPIO DIR register.
- Write 1 to the GPIO CLR register to drive the outputs LOW.
- All peripherals disabled.

Table 15. Static characteristics: Power consumption in active and sleep mode

$T_{amb} = -40\text{ °C to }+105\text{ °C}$, unless otherwise specified. $1.71\text{ V} \leq V_{DD} \leq 3.6\text{ V}$.

Symbol	Parameter	Conditions	Min	Typ ^[2]	Max	Unit	
Active mode^[1]							
I _{DD}	supply current	CoreMark code executed from SRAMX; flash powered down CCLK = 12 MHz	[3][4][5][7]	-	3.3	-	mA
		CCLK = 96 MHz	[3][4][5][7]	-	11	-	mA
		CCLK = 180 MHz	[4][5][7][8]	-	24	-	mA
		CCLK = 220 MHz	[4][5][7][8]	-	30	-	mA
I _{DD}	supply current	CoreMark code executed from flash; CCLK = 12 MHz; 1 system clock flash access time.	[3][4][5][6]	-	4	-	mA
		CCLK = 96 MHz; 5 system clock flash access time.	[3][4][5][6]	-	9.4	-	mA
		CCLK = 180 MHz; 9 system clock flash access time.	[4][5][6][8]	-	17	-	mA
		CCLK = 220 MHz; 8 system clock flash access time.	[4][5][6][8][9]	-	22.4	-	mA
		CCLK = 220 MHz; 9 system clock flash access time.	[4][5][6][8]	-	21.9	-	mA
Sleep mode							
I _{DD}	supply current	CCLK = 12 MHz	[3][4][5][7]	-	1.7	-	mA
		CCLK = 96 MHz	[3][4][5][7]	-	4.1	-	mA
		CCLK = 180 MHz	[4][5][8]	-	8.3	-	mA

- [1] Based on the power API library from the SDK software package available on nxp.com.
- [2] Typical ratings are not guaranteed. Typical values listed are at room temperature (25 °C), 3.3V.
- [3] Clock source FRO. PLL disabled.
- [4] Characterized through bench measurements using typical samples.
- [5] Compiler settings: Keil uVision v.5.21, optimization level 0, optimized for time off.
- [6] Acceleration enable bit in the FLASHCFG register is set to 0. SRAM0 powered. SRAM1, SRAM2, SRAM3, USB SRAM and SRAMX powered down.
- [7] Flash is powered down; SRAM0 and SRAMX are powered; SRAM1, SRAM2, SRAM3, and USB SRAM are powered down. All peripheral clocks disabled.
- [8] Clock source FRO. PLL enabled.
- [9] At 220 MHz the system clock/access time can be lower when compared to 180 MHz because the power library optimizes the on-chip voltage regulator.

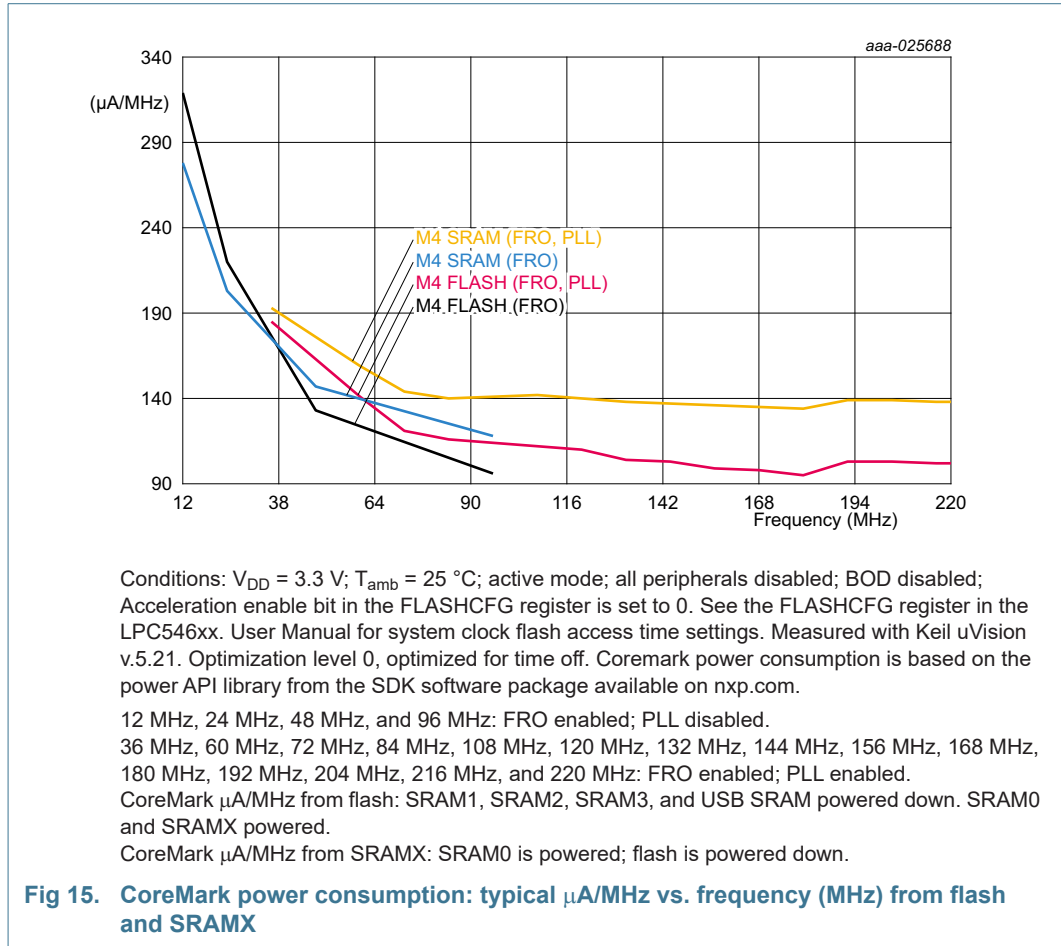

Table 16. Static characteristics: Power consumption in deep-sleep and deep power-down modes
 $T_{amb} = -40\text{ }^{\circ}\text{C}$ to $+105\text{ }^{\circ}\text{C}$, unless otherwise specified, $1.71\text{ V} \leq V_{DD} \leq 2.7\text{ V}$.

Symbol	Parameter	Conditions	Min	Typ ^{[1][2]}	Max ^[3]	Unit	
I _{DD}	supply current	Deep-sleep mode; Flash is powered down					
		SRAMX (32 KB) powered $T_{amb} = 25\text{ }^{\circ}\text{C}$	-	22	69	μA	
		SRAMX (32 KB) powered $T_{amb} = 105\text{ }^{\circ}\text{C}$	-	-	1150	μA	
		Deep power-down mode					
		RTC oscillator input grounded (RTC oscillator disabled) $T_{amb} = 25\text{ }^{\circ}\text{C}$	-	326	1000	nA	
		RTC oscillator input grounded (RTC oscillator disabled) $T_{amb} = 105\text{ }^{\circ}\text{C}$	-	-	27	μA	
		RTC oscillator running with external crystal $V_{DD} = V_{DDA} = V_{REFP} = V_{BAT} = 1.8\text{ V}$	-	340	-	nA	

[1] Typical ratings are not guaranteed. Typical values listed are at room temperature (25 °C), VDD = 1.8 V.
 [2] Characterized through bench measurements using typical samples.

- [3] Tested in production. VDD = 1.71 V. At hot temperature and below 2.0 V, the supply current could increase slightly because of reduction of available RBB (reverse body bias) voltage.

Table 17. Static characteristics: Power consumption in deep-sleep and deep power-down modes

$T_{amb} = -40\text{ }^{\circ}\text{C}$ to $+105\text{ }^{\circ}\text{C}$, unless otherwise specified, $2.7\text{ V} \leq V_{DD} \leq 3.6\text{ V}$.

Symbol	Parameter	Conditions	Min	Typ ^{[1][2]}	Max ^[3]	Unit
I _{DD}	supply current	Deep-sleep mode; Flash is powered down				
		SRAMX (32 KB) powered $T_{amb} = 25\text{ }^{\circ}\text{C}$	-	23	69	μA
		SRAMX (32 KB) powered $T_{amb} = 105\text{ }^{\circ}\text{C}$	-	-	1150	μA
		Deep power-down mode				
		RTC oscillator input grounded (RTC oscillator disabled) $T_{amb} = 25\text{ }^{\circ}\text{C}$	-	464	1500	nA
		RTC oscillator input grounded (RTC oscillator disabled) $T_{amb} = 105\text{ }^{\circ}\text{C}$	-	-	42	μA
		RTC oscillator running with external crystal VDD = VDDA = VREFP = 3.3 V, VBAT = 3.0 V	-	550	-	nA

- [1] Typical ratings are not guaranteed. Typical values listed are at room temperature (25 °C), VDD = 3.3 V.
 [2] Characterized through bench measurements using typical samples.
 [3] Tested in production, VDD = 3.6 V.

Table 18. Static characteristics: Power consumption in deep power-down mode

$T_{amb} = -40\text{ }^{\circ}\text{C}$ to $+105\text{ }^{\circ}\text{C}$, unless otherwise specified, $2.7\text{ V} \leq V_{DD} \leq 3.6\text{ V}$.

Symbol	Parameter	Conditions	Min	Typ ^{[1][2]}	Max	Unit
I _{BAT}	battery supply current	deep power-down mode; RTC oscillator running with external crystal				
		VDD = VDDA = VREFP = 3.3 V, VBAT = 3.0 V	-	0	-	nA
		VDD = VDDA = VREFP = 0 V or tied to ground, VBAT = 3.0 V	-	340 ^[3]	-	nA

- [1] Typical ratings are not guaranteed. Typical values listed are at room temperature (25 °C).
 [2] Characterized through bench measurements using typical samples.
 [3] If VBAT > VDD, the external reset pin must be floating to prevent high VBAT leakage.

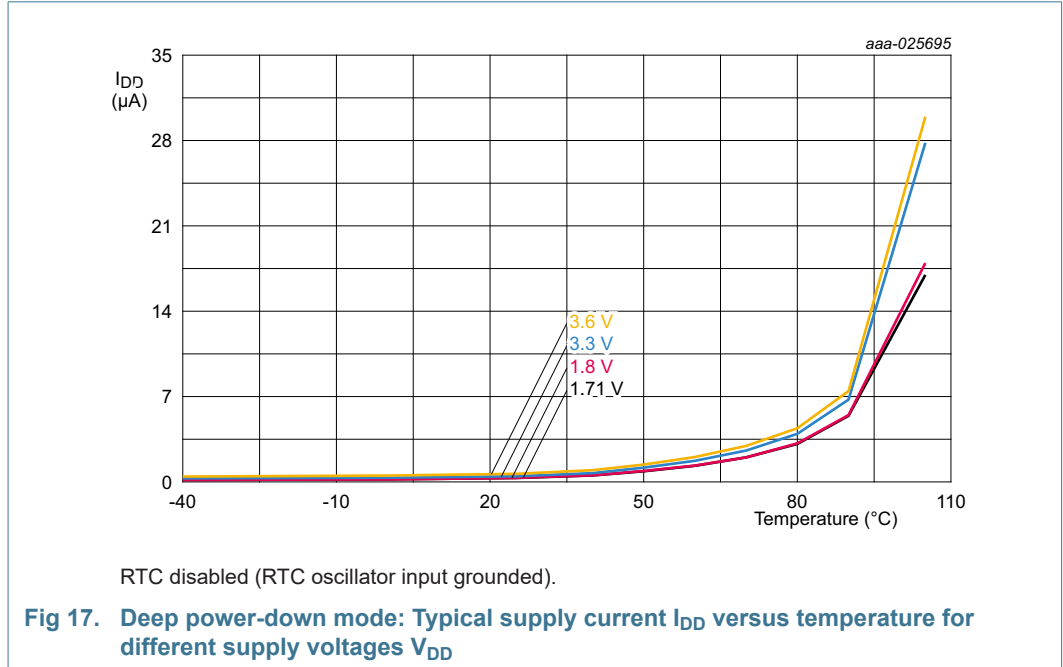
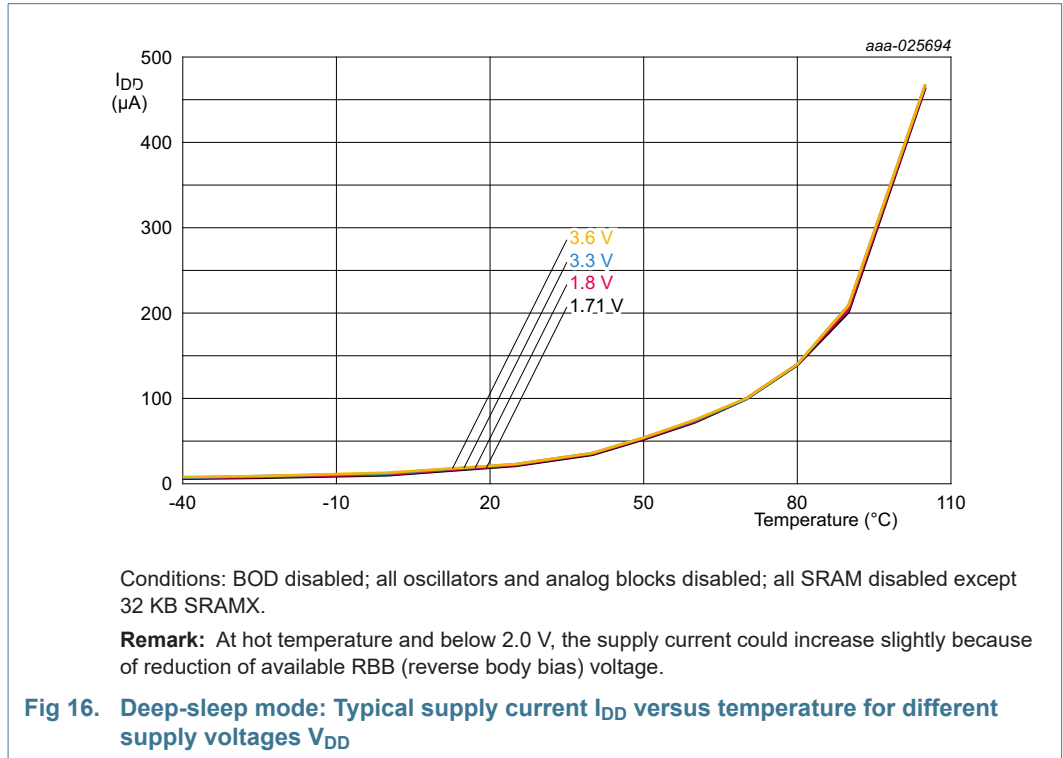

Table 19 shows the typical peripheral power consumption measured on a typical sample at $T_{amb} = 25\text{ }^{\circ}\text{C}$ and $V_{DD} = 3.3\text{ V}$. The supply current per peripheral is measured as the difference in supply current between the peripheral block enabled and the peripheral block disabled using ASYNCAPBCLKCTRL, AHBCLKCTRL0/1/2, and PDRUNCFG0/1

registers. All other blocks are disabled and no code accessing the peripheral is executed. The supply currents are shown for system clock frequencies of 12 MHz, 48 MHz, 96 MHz and 180MHz.

Table 19. Typical peripheral power consumption^{[1][2]}

$V_{DD} = 3.3\text{ V}$; $T_{amb} = 25\text{ °C}$

Peripheral	I _{DD} in uA
FRO	100
WDT OSC	2.0
Flash	200
BOD	2.0
SYSOSC	247

[1] The supply current per peripheral is measured as the difference in supply current between the peripheral block enabled and the peripheral block disabled using PDRUNCFG0/1 registers. All other blocks are disabled and no code accessing the peripheral is executed.

[2] Typical ratings are not guaranteed. Characterized through bench measurements using typical samples.

Table 20. Typical AHB/APB peripheral power consumption ^{[3][4][5]}

$T_{amb} = 25\text{ °C}$, $V_{DD} = 3.3\text{ V}$;

Peripheral	I _{DD} in uA/MHz	I _{DD} in uA/MHz	I _{DD} in uA/MHz	I _{DD} in uA/MHz	I _{DD} in uA/MHz
AHB peripheral	CPU: 12 MHz, sync APB bus: 12 MHz	CPU: 48 MHz, sync APB bus: 48 MHz	CPU: 96 MHz, sync APB bus: 96 MHz	CPU: 180 MHz, sync APB bus: 180 MHz	CPU: 220 MHz, sync APB bus: 220 MHz
USB0 device	0.3	0.3	0.3	0.4	0.5
USB1 device	4.4	4.4	4.4	5.0	6.5
DMIC	0.2	0.2	0.2	0.2	0.3
GPIO0	[1] 0.9	0.9	0.9	1.0	1.4
GPIO1	[1] 0.8	0.8	0.8	1.0	1.4
GPIO2	[1] 1.0	1.0	1.0	1.1	1.4
GPIO3	[1] 1.1	1.1	1.1	1.3	1.7
GPIO4	[1] 1.0	1.0	1.0	1.2	1.6
GPIO5	[1] 0.7	0.7	0.7	0.8	1.1
DMA	0.7	0.7	0.7	0.8	1.1
CRC	1.0	1.0	1.0	1.0	1.4
ADC0	1.6	1.6	1.6	1.9	2.6
SCTimer/PWM	4.5	4.5	4.5	5.3	7.0
Ethernet AVB	24.0	24.0	24.0	28.0	38.0
LCD	13.0	13.0	13.0	15.0	19.0
EEPROM	1.1	1.1	1.1	1.2	1.6
EMC	39.0	39.0	39.0	45.4	60.1
CAN0	10.8	10.8	10.8	12.6	16.5
CAN1	10.7	10.7	10.7	12.4	16.4
SD/MMC	7.9	7.9	7.9	9.3	12.3
Flexcomm Interface 0 (USART, SPI, I ² C)	1.6	1.6	1.6	1.9	2.5

Table 20. Typical AHB/APB peripheral power consumption [3][4][5] $T_{amb} = 25\text{ }^{\circ}\text{C}$, $V_{DD} = 3.3\text{ V}$;

Peripheral		I _{DD} in uA/MHz	I _{DD} in uA/MHz	I _{DD} in uA/MHz	I _{DD} in uA/MHz	I _{DD} in uA/MHz
Flexcomm Interface1 (USART, SPI, I ² C)		1.6	1.6	1.6	1.8	2.4
Flexcomm Interface 2 (USART, SPI, I ² C)		1.7	1.7	1.7	1.9	2.6
Flexcomm Interface 3 (USART, SPI, I ² C)		1.4	1.4	1.4	1.6	2.2
Flexcomm Interface 4 (USART, SPI, I ² C)		1.4	1.5	1.5	1.7	2.3
Flexcomm Interface 5 (USART, SPI, I ² C)		1.7	1.7	1.7	1.9	2.5
Flexcomm Interface 6 (USART, SPI, I ² C, I ² S)		2.0	2.0	2.0	2.3	3.0
Flexcomm Interface 7 (USART, SPI, I ² C, I ² S)		1.6	1.6	1.6	1.9	2.5
Flexcomm Interface 8 (USART, SPI, I ² C)		1.5	1.5	1.5	1.8	2.3
Flexcomm Interface 9 (USART, SPI, I ² C)		1.5	1.5	1.5	1.8	2.3
Sync APB peripheral		CPU: 12 MHz, sync APB bus: 12 MHz	CPU: 48 MHz, sync APB bus: 48 MHz	CPU: 96 MHz, sync APB bus: 96 MHz	CPU: 180 MHz, sync APB bus: 180 MHz	CPU: 220 MHz, sync APB bus: 220 MHz
INPUTMUX	[1]	0.83	0.85	0.86	1.0	1.3
IOCON	[1]	2.67	2.65	2.65	3.13	4.2
PINT		1.1	1.1	1.1	1.3	1.8
GINT0 and GINT1		1.33	1.35	1.34	1.52	2.0
WWDT		0.42	0.42	0.42	0.46	0.6
RTC		0.3	0.3	0.3	0.3	0.4
MRT		0.3	0.3	0.3	0.3	0.4
RIT		0.1	0.1	0.1	0.1	0.1
UTICK		0.2	0.2	0.2	0.2	0.3
CTimer0		0.8	0.8	0.8	0.9	1.3
CTimer1		0.8	0.9	0.9	1.0	1.4
CTimer2		0.83	0.85	0.88	0.99	1.3
Smart card0		2.5	2.5	2.5	2.8	3.7
Smart card1		2.5	2.5	2.5	2.8	3.7
RNG		1.4	1.4	1.4	1.5	2.0
OTP controller		4.0	4.0	4.0	4.5	6.0
SHA		1.2	1.2	1.2	1.3	1.7

Table 20. Typical AHB/APB peripheral power consumption [3][4][5] $T_{amb} = 25\text{ }^{\circ}\text{C}$, $V_{DD} = 3.3\text{ V}$;

Peripheral	I_{DD} in $\mu\text{A}/\text{MHz}$	I_{DD} in $\mu\text{A}/\text{MHz}$	I_{DD} in $\mu\text{A}/\text{MHz}$	I_{DD} in $\mu\text{A}/\text{MHz}$	I_{DD} in $\mu\text{A}/\text{MHz}$
Async APB peripheral	CPU: 12 MHz, Async APB bus: 12 MHz	CPU: 48 MHz, sync APB bus: 12 MHz ^[2]	CPU: 96 MHz, Async APB bus: 12 MHz ^[2]	CPU: 180 MHz, Async APB bus: 12 MHz ^[2]	CPU: 220 MHz, Async APB bus: 12 MHz ^[2]
Timer3	0.9	0.9	0.9	0.9	1.2
Timer4	0.9	0.9	0.9	0.9	1.2

- [1] Turn off the peripheral when the configuration is done.
- [2] For optimal system power consumption, use fixed low frequency Async APB bus when the CPU is at a higher frequency.
- [3] The supply current per peripheral is measured as the difference in supply current between the peripheral block enabled and the peripheral block disabled using ASYNCAPBCLKCTRL, AHBCLKCTRL0/1, and PDRUNCFG0/1 registers. All other blocks are disabled and no code accessing the peripheral is executed.
- [4] The supply currents are shown for system clock frequencies of 12 MHz, 48 MHz, 96 MHz, 180 MHz, and 220 MHz.
- [5] Typical ratings are not guaranteed. Characterized through bench measurements using typical samples.

10.5 Pin characteristics

Table 21. Static characteristics: pin characteristics

$T_{amb} = -40\text{ }^{\circ}\text{C}$ to $+105\text{ }^{\circ}\text{C}$, unless otherwise specified. $1.71\text{ V} \leq V_{DD} \leq 3.6\text{ V}$ unless otherwise specified. Values tested in production unless otherwise specified.

Symbol	Parameter	Conditions	Min	Typ ^[1]	Max	Unit
RESET pin						
V_{IH}	HIGH-level input voltage		$0.8 \times V_{DD}$	-	5.0	V
V_{IL}	LOW-level input voltage		-0.5	-	$0.3 \times V_{DD}$	V
V_{hys}	hysteresis voltage		^[14] $0.05 \times V_{DD}$	-	-	V
Standard I/O pins						
Input characteristics						
I_{IL}	LOW-level input current	$V_I = 0\text{ V}$; on-chip pull-up resistor disabled.	-	3.0	180	nA
I_{IH}	HIGH-level input current	$V_I = V_{DD}$; $V_{DD} = 3.6\text{ V}$; for RESETN pin.		3.0	180	nA
I_{IH}	HIGH-level input current	$V_I = V_{DD}$; on-chip pull-down resistor disabled	-	3.0	180	nA
V_I	input voltage	pin configured to provide a digital function; $V_{DD} > 1.8\text{ V}$	^[3] 0	-	5.0	V
		$V_{DD} = 0\text{ V}$	0	-	3.6	V
V_{IH}	HIGH-level input voltage	$1.71\text{ V} \leq V_{DD} < 2.7\text{ V}$	1.5	-	5.0	V
		$2.7\text{ V} \leq V_{DD} \leq 3.6\text{ V}$	2.0	-	5.0	V
V_{IL}	LOW-level input voltage	$1.71\text{ V} \leq V_{DD} < 2.7\text{ V}$	-0.5	-	+0.4	V
		$2.7\text{ V} \leq V_{DD} \leq 3.6\text{ V}$	-0.5	-	+0.8	V
V_{hys}	hysteresis voltage		^[14] $0.1 \times V_{DD}$	-	-	V
Output characteristics						

Table 21. Static characteristics: pin characteristics ...continued

$T_{amb} = -40\text{ }^{\circ}\text{C}$ to $+105\text{ }^{\circ}\text{C}$, unless otherwise specified. $1.71\text{ V} \leq V_{DD} \leq 3.6\text{ V}$ unless otherwise specified. Values tested in production unless otherwise specified.

Symbol	Parameter	Conditions	Min	Typ ^[1]	Max	Unit	
V_O	output voltage	output active	0	-	V_{DD}	V	
I_{OZ}	OFF-state output current	$V_O = 0\text{ V}$; $V_O = V_{DD}$; on-chip pull-up/pull-down resistors disabled	-	3	180	nA	
V_{OH}	HIGH-level output voltage	$I_{OH} = -4\text{ mA}$; $1.71\text{ V} \leq V_{DD} < 2.7\text{ V}$	$V_{DD} - 0.4$	-	-	V	
		$I_{OH} = -6\text{ mA}$; $2.7\text{ V} \leq V_{DD} \leq 3.6\text{ V}$	$V_{DD} - 0.4$	-	-	V	
V_{OL}	LOW-level output voltage	$I_{OL} = 4\text{ mA}$; $1.71\text{ V} \leq V_{DD} < 2.7\text{ V}$	-	-	0.4	V	
		$I_{OL} = 6\text{ mA}$; $2.7\text{ V} \leq V_{DD} \leq 3.6\text{ V}$	-	-	0.4	V	
I_{OH}	HIGH-level output current	$V_{OH} = V_{DD} - 0.4\text{ V}$; $1.71\text{ V} \leq V_{DD} < 2.7\text{ V}$	4.0	-	-	mA	
		$V_{OH} = V_{DD} - 0.4\text{ V}$; $2.7\text{ V} \leq V_{DD} \leq 3.6\text{ V}$	6.0	-	-	mA	
I_{OL}	LOW-level output current	$V_{OL} = 0.4\text{ V}$; $1.71\text{ V} \leq V_{DD} < 2.7\text{ V}$	4.0	-	-	mA	
		$V_{OL} = 0.4\text{ V}$; $2.7\text{ V} \leq V_{DD} \leq 3.6\text{ V}$	6.0	-	-	mA	
I_{OHS}	HIGH-level short-circuit output current drive HIGH; connected to ground;	$1.71\text{ V} \leq V_{DD} < 2.7\text{ V}$	[2][4]	-	35	mA	
		$2.7\text{ V} \leq V_{DD} \leq 3.6\text{ V}$	-	-	87	mA	
I_{OLS}	LOW-level short-circuit output current drive LOW; connected to V_{DD}	$1.71\text{ V} \leq V_{DD} < 2.7\text{ V}$	[2][4]	-	30	mA	
		$2.7\text{ V} \leq V_{DD} \leq 3.6\text{ V}$	-	-	77	mA	
Weak input pull-up/pull-down characteristics							
I_{pd}	pull-down current	$V_I = V_{DD}$	25	-	80	μA	
		$V_I = 5\text{ V}$	[2]	80	100	μA	
I_{pu}	pull-up current	$V_I = 0\text{ V}$	-25	-	-80	μA	
		$V_{DD} < V_I < 5\text{ V}$	[2][7]	6	30	μA	
Open-drain I²C pins							
V_{IH}	HIGH-level input voltage	$1.71\text{ V} \leq V_{DD} < 2.7\text{ V}$	$0.7 \times V_{DD}$	-	-	V	
		$2.7\text{ V} \leq V_{DD} \leq 3.6\text{ V}$	$0.7 \times V_{DD}$	-	-	V	
V_{IL}	LOW-level input voltage	$1.71\text{ V} \leq V_{DD} < 2.7\text{ V}$	0	-	$0.3 \times V_{DD}$	V	
		$2.7\text{ V} \leq V_{DD} \leq 3.6\text{ V}$	0	-	$0.3 \times V_{DD}$	V	
V_{hys}	hysteresis voltage		$0.1 \times V_{DD}$	-	-	V	
I_{LI}	input leakage current	$V_I = V_{DD}$	[5]	-	2.5	3.5	μA
		$V_I = 5\text{ V}$	-	-	5.5	10	μA
I_{OL}	LOW-level output current	$V_{OL} = 0.4\text{ V}$; pin configured for standard mode or fast mode	4.0	-	-	mA	
		$V_{OL} = 0.4\text{ V}$; pin configured for Fast-mode Plus	20	-	-	mA	

Table 21. Static characteristics: pin characteristics ...continued

$T_{amb} = -40\text{ }^{\circ}\text{C}$ to $+105\text{ }^{\circ}\text{C}$, unless otherwise specified. $1.71\text{ V} \leq V_{DD} \leq 3.6\text{ V}$ unless otherwise specified. Values tested in production unless otherwise specified.

Symbol	Parameter	Conditions	Min	Typ ^[1]	Max	Unit
USB0_DM and USB0_DP pins						
V_I	input voltage		0	-	V_{DD}	V
V_{IH}	HIGH-level input voltage		2.0	-	-	V
V_{IL}	LOW-level input voltage		-	-	0.8	V
V_{hys}	hysteresis voltage		0.4	-	-	V
Z_{out}	output impedance		[11] 33.0	-	44	Ω
V_{OH}	HIGH-level output voltage		[12] 2.8	-	-	V
V_{OL}	LOW-level output voltage		[13] -	-	0.3	V
I_{OH}	HIGH-level output current	$V_{OH} = V_{DD} - 0.3\text{ V}$	[9][10] 38	-	74	mA
		$V_{OH} = V_{DD} - 0.3\text{ V}$	[10][11] 6.0	-	9.0	mA
I_{OL}	LOW-level output current	$V_{OL} = 0.3\text{ V}$	[9][10] 38	-	74	mA
		$V_{OL} = 0.3\text{ V}$	[10][11] 6.0	-	9.0	mA
I_{OLS}	LOW-level short-circuit output current	drive LOW; pad connected to ground	[10] -	-	100	mA
I_{OHS}	HIGH-level short-circuit output current	drive HIGH; pad connected to ground	[10] -	-	100	mA
Pin capacitance						
C_{io}	input/output capacitance	I ² C-bus pins	[8] -	-	6.0	pF
		pins with digital functions only	[6] -	-	2.0	pF
		Pins with digital and analog functions	[6] -	-	7.0	pF

[1] Typical ratings are not guaranteed. The values listed are at room temperature (25 °C), nominal supply voltage.

[2] Based on characterization. Not tested in production.

[3] With respect to ground.

[4] Allowed as long as the current limit does not exceed the maximum current allowed by the device.

[5] To V_{SS} .

[6] The values specified are simulated and absolute values, including package/bondwire capacitance.

[7] The weak pull-up resistor is connected to the V_{DD} rail and pulls up the I/O pin to the V_{DD} level.

[8] The value specified is a simulated value, excluding package/bondwire capacitance.

[9] Without $33\ \Omega \pm 2\%$ series external resistor.

[10] The parameter values specified are simulated and absolute values.

[11] With $33\ \Omega \pm 2\%$ series external resistor.

[12] With $15\ \text{k}\Omega \pm 5\%$ resistor to V_{SS} .

[13] With $1.5\ \text{k}\Omega \pm 5\%$ resistor to 3.6 V external pull-up.

[14] Guaranteed by design, not tested in production.

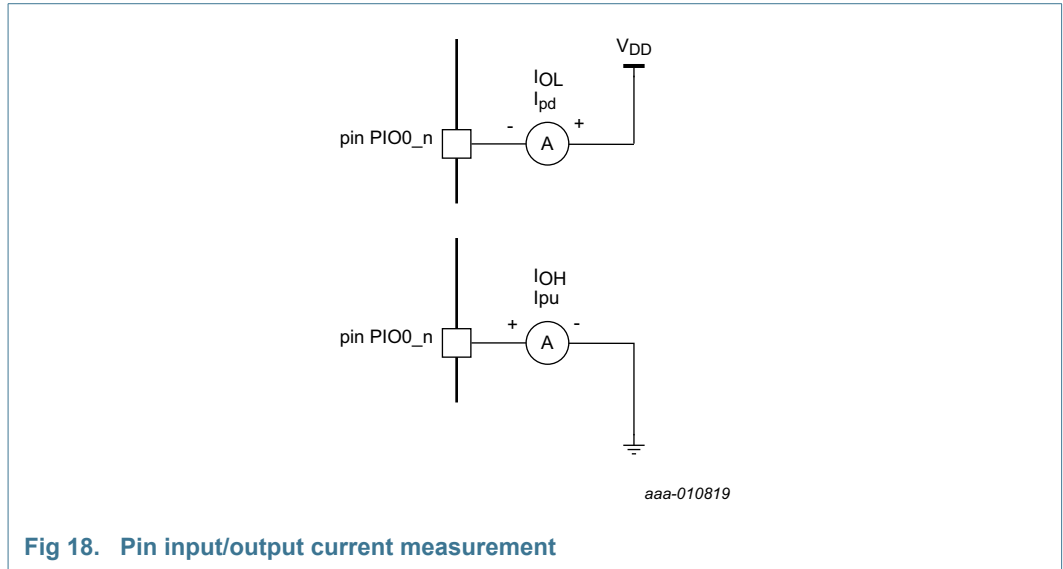

Fig 18. Pin input/output current measurement

10.5.1 Electrical pin characteristics

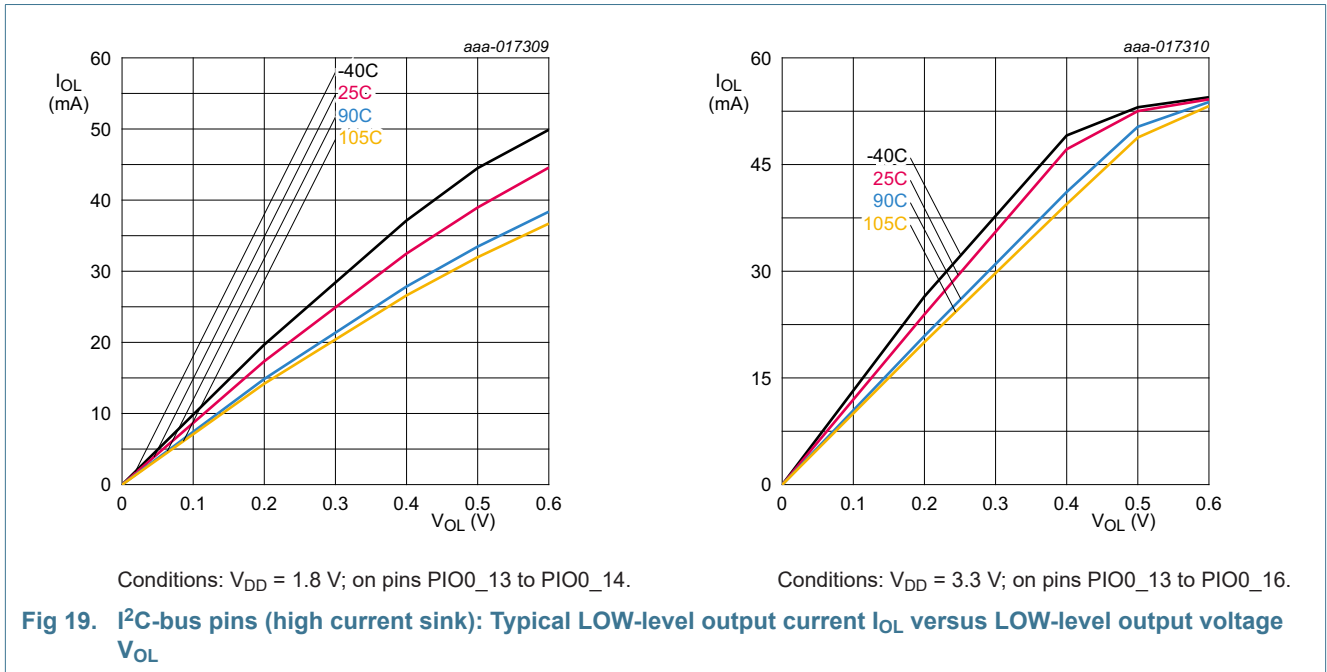
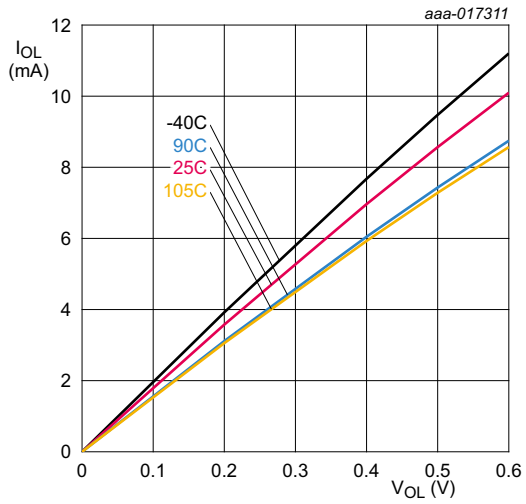
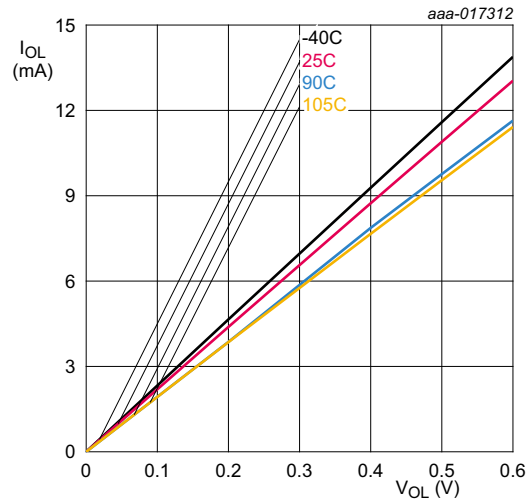

Fig 19. I²C-bus pins (high current sink): Typical LOW-level output current I_{OL} versus LOW-level output voltage V_{OL}



Conditions: $V_{DD} = 1.8\text{ V}$; on standard port pins.



Conditions: $V_{DD} = 3.3\text{ V}$; on standard port pins.

Fig 20. Typical LOW-level output current I_{OL} versus LOW-level output voltage V_{OL}

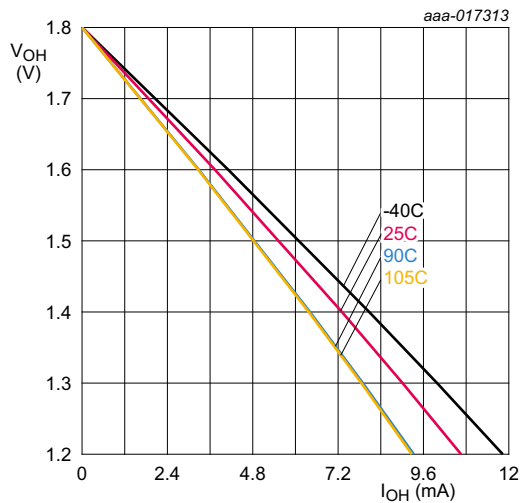

Conditions: $V_{DD} = 1.8\text{ V}$; on standard port pins.

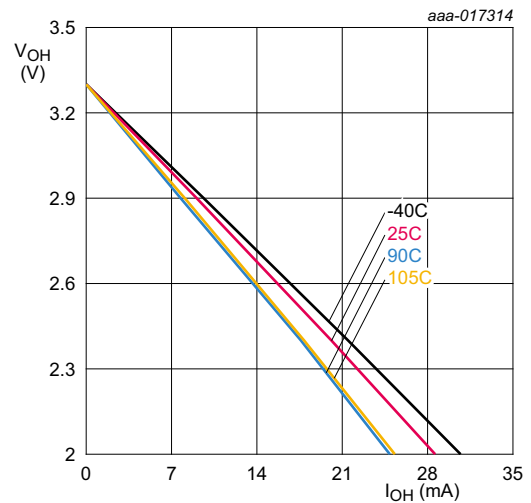

Conditions: $V_{DD} = 3.3\text{ V}$; on standard port pins.

Fig 21. Typical HIGH-level output voltage V_{OH} versus HIGH-level output source current I_{OH}

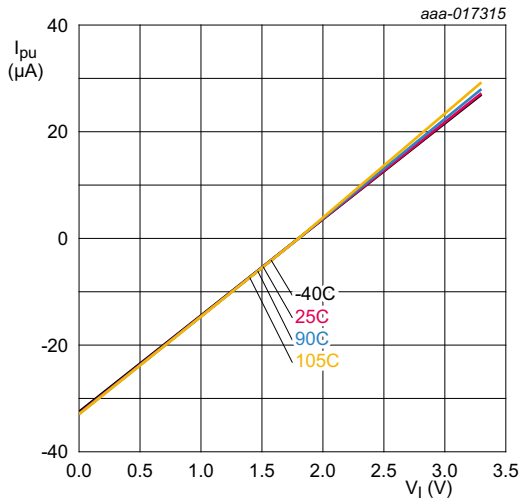

Conditions: $V_{DD} = 1.8\text{ V}$; on standard port pins.

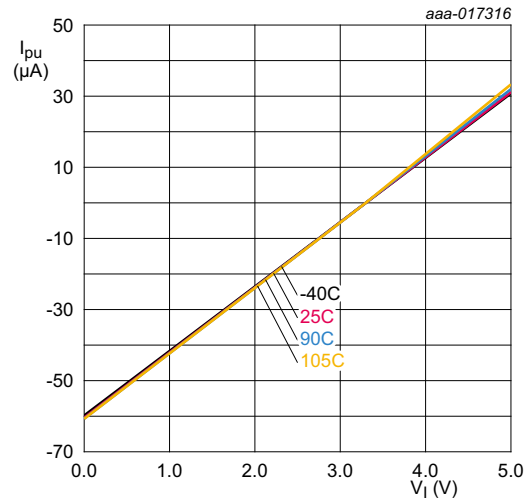

Conditions: $V_{DD} = 3.3\text{ V}$; on standard port pins.

Fig 22. Typical pull-up current I_{PU} versus input voltage V_I

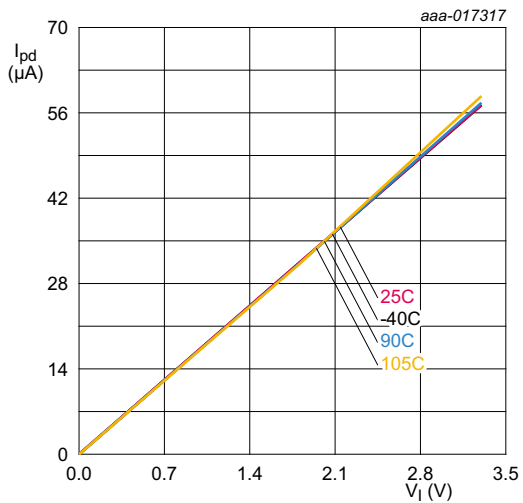

Conditions: $V_{DD} = 1.8\text{ V}$; on standard port pins.

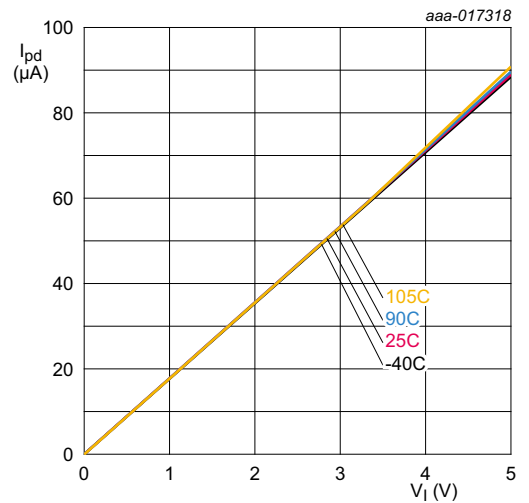

Conditions: $V_{DD} = 3.3\text{ V}$; on standard port pins.

Fig 23. Typical pull-down current I_{PD} versus input voltage V_I

11. Dynamic characteristics

11.1 Flash memory

Table 22. Flash characteristics

$T_{amb} = -40\text{ °C to }+105\text{ °C}$, unless otherwise specified. $V_{DD} = 1.71\text{ V to }3.6\text{ V}$

Symbol	Parameter	Conditions	Min	Typ	Max	Unit	
N_{endu}	endurance	sector erase/program	[1]	10000	-	-	cycles
		page erase/program; page in a sector		1000	-	-	cycles
t_{ret}	retention time	powered		10	-	-	years
		unpowered		10	-	-	years
t_{er}	erase time	page, sector, or multiple consecutive sectors		-	100	-	ms
t_{prog}	programming time		[2]	-	1	-	ms

[1] Number of erase/program cycles.

[2] Programming times are given for writing 256 bytes from RAM to the flash.

11.2 EEPROM

Table 23. EEPROM characteristics

$T_{amb} = -40\text{ °C to }+85\text{ °C}$; $V_{DD} = 1.71\text{ V to }3.6\text{ V}$.

Symbol	Parameter	Conditions	Min	Typ	Max	Unit
f_{clk}	clock frequency		800	1500	1600	kHz
N_{endu}	endurance		100000	-	-	cycles
t_{ret}	retention time	$T_{amb} = -40\text{ °C to }+85\text{ °C}$	20	-	-	years
t_a	access time	read	-	100	-	ns
		erase/program; $f_{clk} = 1500\text{ kHz}$	-	1.99	-	ms
		erase/program; $f_{clk} = 1600\text{ kHz}$	-	1.87	-	ms
t_{wait}	wait time	read; RPHASE1 [1]	70	-	-	ns
		read; RPHASE2 [1]	35	-	-	ns
		write; PHASE1 [1]	20	-	-	ns
		write; PHASE2 [1]	40	-	-	ns
		write; PHASE3 [1]	10	-	-	ns

[1] See the LPC546xx. user manual, UM10912 on how to program the wait states for the different read (RPHASEx) and erase/program phases (PHASEx).

Remark: EEPROM is not accessible in deep-sleep and deep power-down modes

11.3 I/O pins

Table 24. Dynamic characteristic: I/O pins^[1] $T_{amb} = -40\text{ }^{\circ}\text{C}$ to $+105\text{ }^{\circ}\text{C}$; $1.71\text{ V} \leq V_{DD} \leq 3.6\text{ V}$

Symbol	Parameter	Conditions		Min	Typ	Max	Unit
Standard I/O pins - normal drive strength							
t_r	rise time	pin configured as output; SLEW = 1 (Fast-mode); $2.7\text{ V} \leq V_{DD} \leq 3.6\text{ V}$	[2][3]	1.0	-	2.5	ns
		$1.71\text{ V} \leq V_{DD} \leq 1.98\text{ V}$		1.6	-	3.8	ns
t_f	fall time	pin configured as output; SLEW = 1 (Fast-mode); $2.7\text{ V} \leq V_{DD} \leq 3.6\text{ V}$	[2][3]	0.9	-	2.5	ns
		$1.71\text{ V} \leq V_{DD} \leq 1.98\text{ V}$		1.7	-	4.1	ns
t_r	rise time	pin configured as output; SLEW = 0 (standard mode); $2.7\text{ V} \leq V_{DD} \leq 3.6\text{ V}$	[2][3]	1.9	-	4.3	ns
		$1.71\text{ V} \leq V_{DD} \leq 1.98\text{ V}$		2.9	-	7.8	ns
t_f	fall time	pin configured as output; SLEW = 0 (standard mode); $2.7\text{ V} \leq V_{DD} \leq 3.6\text{ V}$	[2][3]	1.9	-	4.0	ns
		$1.71\text{ V} \leq V_{DD} \leq 1.98\text{ V}$		2.7	-	6.7	ns
t_r	rise time	pin configured as input	[4]	0.3	-	1.3	ns
t_f	fall time	pin configured as input	[4]	0.2	-	1.2	ns

[1] Simulated data, not tested in production.

[2] Simulated using 10 cm of 50 Ω PCB trace with 5 pF receiver input. Rise and fall times measured between 80 % and 20 % of the full output signal level.

[3] The slew rate is configured in the IOCON block the SLEW bit. See the LPC546xx user manual.

[4] $C_L = 20\text{ pF}$. Rise and fall times measured between 90 % and 10 % of the full input signal level.

11.4 Wake-up process

Table 25. Dynamic characteristic: Typical wake-up times from low power modes

$V_{DD} = 3.3\text{ V}$; $T_{amb} = 25\text{ °C}$; using FRO as the system clock.

Symbol	Parameter	Conditions		Min	Typ ^[1]	Max	Unit
t_{wake}	wake-up time	from sleep mode	[2][3]	-	2.0	-	μs
		from deep-sleep mode; SRAMx powered. SRAM0, SRAM1, SRAM2, SRAM3, and USB SRAM powered down.	[2][5]	-	150	-	μs
		from deep power-down mode; RTC disabled; using $\overline{\text{RESET}}$ pin.	[4][5]	-	1.2	-	ms

- [1] Typical ratings are not guaranteed. The values listed are at room temperature (25 °C), nominal supply voltages.
- [2] The wake-up time measured is the time between when a GPIO input pin is triggered to wake the device up from the low power modes and from when a GPIO output pin is set in the interrupt service routine (ISR) wake-up handler.
- [3] FRO enabled, all peripherals off. PLL disabled.
- [4] RTC disabled. Wake up from deep power-down causes the part to go through entire reset process. The wake-up time measured is the time between when the $\overline{\text{RESET}}$ pin is triggered to wake the device up and when a GPIO output pin is set in the reset handler.
- [5] FRO disabled.

11.5 External memory interface

Table 26. Dynamic characteristics: Static external memory interface

$C_L = 10$ pF balanced loading on all pins, $T_{amb} = -40$ °C to 105 °C, $V_{DD} = 2.7$ V to 3.6 V. Max EMC clock = 100 MHz. Input slew = 1 ns; SLEW set to fast-mode. Parameters sampled at the 90 % and 10 % level of the rising or falling edge. Excluding delays introduced by external device and PCB; Values based on simulation.

Symbol	Parameter ^[1]	Conditions ^[1]	Min	Typ	Max	Unit
Read cycle parameters						
t_{CSLAV}	\overline{CS} LOW to address valid time	RD ₁	-1.2	-	1.6	ns
t_{CSLOEL}	\overline{CS} LOW to \overline{OE} LOW time	RD ₂	^[2] $0.4 + T_{cy(clk)} \times \text{WAITOEN}$	-	$0.8 + T_{cy(clk)} \times \text{WAITOEN}$	ns
$t_{CSLBLSL}$	\overline{CS} LOW to \overline{BLS} LOW time	RD ₃ ; PB = 1	^{[2][6]} -1.6	-	0	ns
t_{OELOEH}	\overline{OE} LOW to \overline{OE} HIGH time	RD ₄	^[2] $(\text{WAITRD} - \text{WAITOEN} + 1) \times T_{cy(clk)}$	-	$0.3 + (\text{WAITRD} - \text{WAITOEN} + 1) \times T_{cy(clk)}$	ns
t_{am}	memory access time	RD ₅	^{[2][3]} -6.7 + $(\text{WAITRD} - \text{WAITOEN} + 1) \times T_{cy(clk)}$	-	-	ns
$t_{h(D)}$	data input hold time	RD ₆	^{[2][4]} -4.8	-	-	ns
$t_{CSHBLSH}$	\overline{CS} HIGH to \overline{BLS} HIGH time	PB = 1	^[6] 0.8	-	1.5	ns
t_{CSHOEH}	\overline{CS} HIGH to \overline{OE} HIGH time		^[2] 0.5	-	0.9	ns
t_{OEHANV}	\overline{OE} HIGH to address invalid time		^[2] -0.4	-	0	ns
t_{deact}	deactivation time	RD ₇	^[2] 0.5	-	0.9	ns
Write cycle parameters						
t_{CSLAV}	\overline{CS} LOW to address valid time	WR ₁	0.1	-	0.5	ns
t_{CSLDV}	\overline{CS} LOW to data valid time	WR ₂	1.0	-	2.2	ns
t_{CSLWEL}	\overline{CS} LOW to \overline{WE} LOW time	WR ₃ ; PB = 1	^{[2][6]} -0.6	-	0	ns
$t_{CSLBLSL}$	\overline{CS} LOW to \overline{BLS} LOW time	WR ₄ ; PB = 1	^{[2][6]} -1.2	-	0	ns
t_{WELWEH}	\overline{WE} LOW to \overline{WE} HIGH time	WR ₅ ; PB = 1	^{[2][6]} $(\text{WAITWR} - \text{WAITWEN} + 1) \times T_{cy(clk)}$	-	$0.1 + (\text{WAITWR} - \text{WAITWEN} + 1) \times T_{cy(clk)}$	ns
$t_{BLSBLSH}$	\overline{BLS} LOW to \overline{BLS} HIGH time	PB = 1	^{[2][6]} 2.5	-	5.5	ns
t_{WEHDNV}	\overline{WE} HIGH to data invalid time	WR ₆ ; PB = 1	^{[2][6]} 1.6	-	2.9	ns
t_{WEHEOW}	\overline{WE} HIGH to end of write time	WR ₇ ; PB = 1	^{[2][5][6]} 0.6	-	0.9	ns

Table 26. Dynamic characteristics: Static external memory interface ...continued

$C_L = 10$ pF balanced loading on all pins, $T_{amb} = -40$ °C to 105 °C, $V_{DD} = 2.7$ V to 3.6 V. Max EMC clock = 100 MHz. Input slew = 1 ns; SLEW set to fast-mode. Parameters sampled at the 90 % and 10 % level of the rising or falling edge. Excluding delays introduced by external device and PCB; Values based on simulation.

Symbol	Parameter ^[1]	Conditions ^[1]	Min	Typ	Max	Unit
$t_{BLSHDNV}$	\overline{BLS} HIGH to data invalid time	PB = 1	[6] -0.8	-	0	ns
t_{WEHAVN}	\overline{WE} HIGH to address invalid time	PB = 1	[6] 0.6	-	0.9	ns
t_{deact}	deactivation time	WR ₈ ; PB = 0; PB = 1	[2][6] -0.8	-	0	ns
t_{CSLBLS}	\overline{CS} LOW to \overline{BLS} LOW	WR ₉ ; PB = 0	[2][6] -1.2 + (WAITWEN + 1) $\times T_{cy(clk)}$	-	(WAITWEN + 1) $\times T_{cy(clk)}$	ns
$t_{BLSLBSH}$	\overline{BLS} LOW to \overline{BLS} HIGH time	WR ₁₀ ; PB = 0	[2][6] 2.5 + (WAITWR – WAITWEN + 1) \times $T_{cy(clk)}$	-	5.5 + (WAITWR – WAITWEN + 1) \times $T_{cy(clk)}$	ns
$t_{BLSHEOW}$	\overline{BLS} HIGH to end of write time	WR ₁₁ ; PB = 0	[2][5][6] -0.8 + $T_{cy(clk)}$	-	$T_{cy(clk)}$	ns
$t_{BLSHDNV}$	\overline{BLS} HIGH to data invalid time	WR ₁₂ ; PB = 0	[2][6] 0.2 + $T_{cy(clk)}$	-	0.5 + $T_{cy(clk)}$	ns

[1] Parameters are shown as RD_n or WD_n in Figure 24 as indicated in the Conditions column.

[2] $T_{cy(clk)} = 1/EMC_CLK$ (see UM10912 LPC546xx manual).

[3] Latest of address valid, $\overline{EMC_CSx}$ LOW, $\overline{EMC_OE}$ LOW, $\overline{EMC_BLSx}$ LOW (PB = 1).

[4] After End Of Read (EOR): Earliest of $\overline{EMC_CSx}$ HIGH, $\overline{EMC_OE}$ HIGH, $\overline{EMC_BLSx}$ HIGH (PB = 1), address invalid.

[5] End Of Write (EOW): Earliest of address invalid, $\overline{EMC_CSx}$ HIGH, $\overline{EMC_BLSx}$ HIGH (PB = 1).

[6] The byte lane state bit, PB, enables different types of memory to be connected (see the `STATICCONFIG[0:3]` register in the UM10912 LPC546xx manual).

Table 27. Dynamic characteristics: Static external memory interface

$C_L = 20$ pF balanced loading on all pins, $T_{amb} = -40$ °C to 105 °C, $V_{DD} = 2.7$ V to 3.6 V. Max EMC clock = 100 MHz. Input slew = 1 ns; SLEW set to fast-mode. Parameters sampled at the 90 % and 10 % level of the rising or falling edge. Excluding delays introduced by external device and PCB; Values based on simulation.

Symbol	Parameter ^[1]	Conditions ^[1]	Min	Typ	Max	Unit
Read cycle parameters						
t_{CSLAV}	\overline{CS} LOW to address valid time	RD ₁	-1.2	-	1.6	ns
t_{CSLOEL}	\overline{CS} LOW to \overline{OE} LOW time	RD ₂	[2] 0.5 + $T_{cy(clk)} \times$ WAITOEN	-	0.8 + $T_{cy(clk)} \times$ WAITOEN	ns
t_{CSLBLS}	\overline{CS} LOW to \overline{BLS} LOW time	RD ₃ ; PB = 1	[2][6] -2.3	-	0	ns
t_{OELOEH}	\overline{OE} LOW to \overline{OE} HIGH time	RD ₄	[2] (WAITRD – WAITOEN + 1) \times $T_{cy(clk)}$	-	0.3 + (WAITRD – WAITOEN + 1) \times $T_{cy(clk)}$	ns
t_{am}	memory access time	RD ₅	[2][3] -7.9 + (WAITRD – WAITOEN + 1) \times $T_{cy(clk)}$	-	-	ns

Table 27. Dynamic characteristics: Static external memory interface ...continued

$C_L = 20$ pF balanced loading on all pins, $T_{amb} = -40$ °C to 105 °C, $V_{DD} = 2.7$ V to 3.6 V. Max EMC clock = 100 MHz. Input slew = 1 ns; SLEW set to fast-mode. Parameters sampled at the 90 % and 10 % level of the rising or falling edge. Excluding delays introduced by external device and PCB; Values based on simulation.

Symbol	Parameter ^[1]	Conditions ^[1]	Min	Typ	Max	Unit
$t_{h(D)}$	data input hold time	RD ₆	^{[2][4]} -5.5	-	-	ns
$t_{CSHBLSH}$	\overline{CS} HIGH to \overline{BLS} HIGH time	PB = 1	^[6] 0.7	-	1.5	ns
t_{CSHOEH}	\overline{CS} HIGH to \overline{OE} HIGH time		^[2] 0.5	-	0.9	ns
t_{OEHANV}	\overline{OE} HIGH to address invalid time	RD ₈	^[2] -0.4	-	0	ns
t_{deact}	deactivation time	RD ₇	^[2] 0.5	-	0.9	ns
Write cycle parameters^[2]						
t_{CSLAV}	\overline{CS} LOW to address valid time	WR ₁	0.1	-	0.5	ns
t_{CSLDV}	\overline{CS} LOW to data valid time	WR ₂	1	-	2.2	ns
t_{CSLWEL}	\overline{CS} LOW to \overline{WE} LOW time	WR ₃ ; PB = 1	^{[2][6]} -0.5 + $(WAITWEN + 1) \times T_{cy(clk)}$	-	$(WAITWEN + 1) \times T_{cy(clk)}$	ns
$t_{CSLBLSL}$	\overline{CS} LOW to \overline{BLS} LOW time	WR ₄ ; PB = 1	^{[2][6]} -1.9	-	0	ns
t_{WELWEH}	\overline{WE} LOW to \overline{WE} HIGH time	WR ₅ ; PB = 1	^{[2][6]} -0.1 + $(WAITWEN + 1) \times T_{cy(clk)}$	-	$(WAITWEN + 1) \times T_{cy(clk)}$	ns
$t_{BLSLBSLH}$	\overline{BLS} LOW to \overline{BLS} HIGH time	PB = 1	^{[2][6]} 3.1	-	6.7	ns
t_{WEHDNV}	\overline{WE} HIGH to data invalid time	WR ₆ ; PB = 1	^{[2][6]} 1.6 + $T_{cy(clk)}$	-	2.8 + $T_{cy(clk)}$	ns
t_{WEHEOW}	\overline{WE} HIGH to end of write time	WR ₇ ; PB = 1	^{[2][5][6]} 0.5 + $T_{cy(clk)}$	-	0.8 + $T_{cy(clk)}$	ns
$t_{BLSHDNV}$	\overline{BLS} HIGH to data invalid time	PB = 1	^[6] -0.8	-	0	ns
t_{WEHANV}	\overline{WE} HIGH to address invalid time	PB = 1	^[6] 0.5	-	0.8	ns
t_{deact}	deactivation time	WR ₈ ; PB = 0; PB = 1	^{[2][6]} -0.8	-	0	ns
$t_{CSLBLSL}$	\overline{CS} LOW to \overline{BLS} LOW	WR ₉ ; PB = 0	^{[2][6]} -1.9 + $(WAITWEN + 1) \times T_{cy(clk)}$	-	$(WAITWEN + 1) \times T_{cy(clk)}$	ns
$t_{BLSLBSLH}$	\overline{BLS} LOW to \overline{BLS} HIGH time	WR ₁₀ ; PB = 0	^{[2][6]} 3.1 + $(WAITWR - WAITWEN + 1) \times T_{cy(clk)}$	-	6.7 + $(WAITWR - WAITWEN + 1) \times T_{cy(clk)}$	ns
$t_{BLSHEOW}$	\overline{BLS} HIGH to end of write time	WR ₁₁ ; PB = 0	^{[2][5][6]} -0.8 + $T_{cy(clk)}$	-	$T_{cy(clk)}$	ns
$t_{BLSHDNV}$	\overline{BLS} HIGH to data invalid time	WR ₁₂ ; PB = 0	^{[2][6]} 0.2 + $T_{cy(clk)}$	-	0.5 + $T_{cy(clk)}$	ns

[1] Parameters are shown as RD_n or WD_n in [Figure 24](#) as indicated in the Conditions column.

- [2] $T_{cy(clk)} = 1/EMC_CLK$ (see *UM10912 LPC546xx manual*).
- [3] Latest of address valid, $\overline{EMC_CSx}$ LOW, $\overline{EMC_OE}$ LOW, $\overline{EMC_BLSx}$ LOW (PB = 1).
- [4] After End Of Read (EOR): Earliest of $\overline{EMC_CSx}$ HIGH, $\overline{EMC_OE}$ HIGH, $\overline{EMC_BLSx}$ HIGH (PB = 1), address invalid.
- [5] End Of Write (EOW): Earliest of address invalid, $\overline{EMC_CSx}$ HIGH, $\overline{EMC_BLSx}$ HIGH (PB = 1).
- [6] The byte lane state bit, PB, enables different types of memory to be connected (see *the STATICCONFIG[0:3] register in the UM10912 LPC546xx manual*).

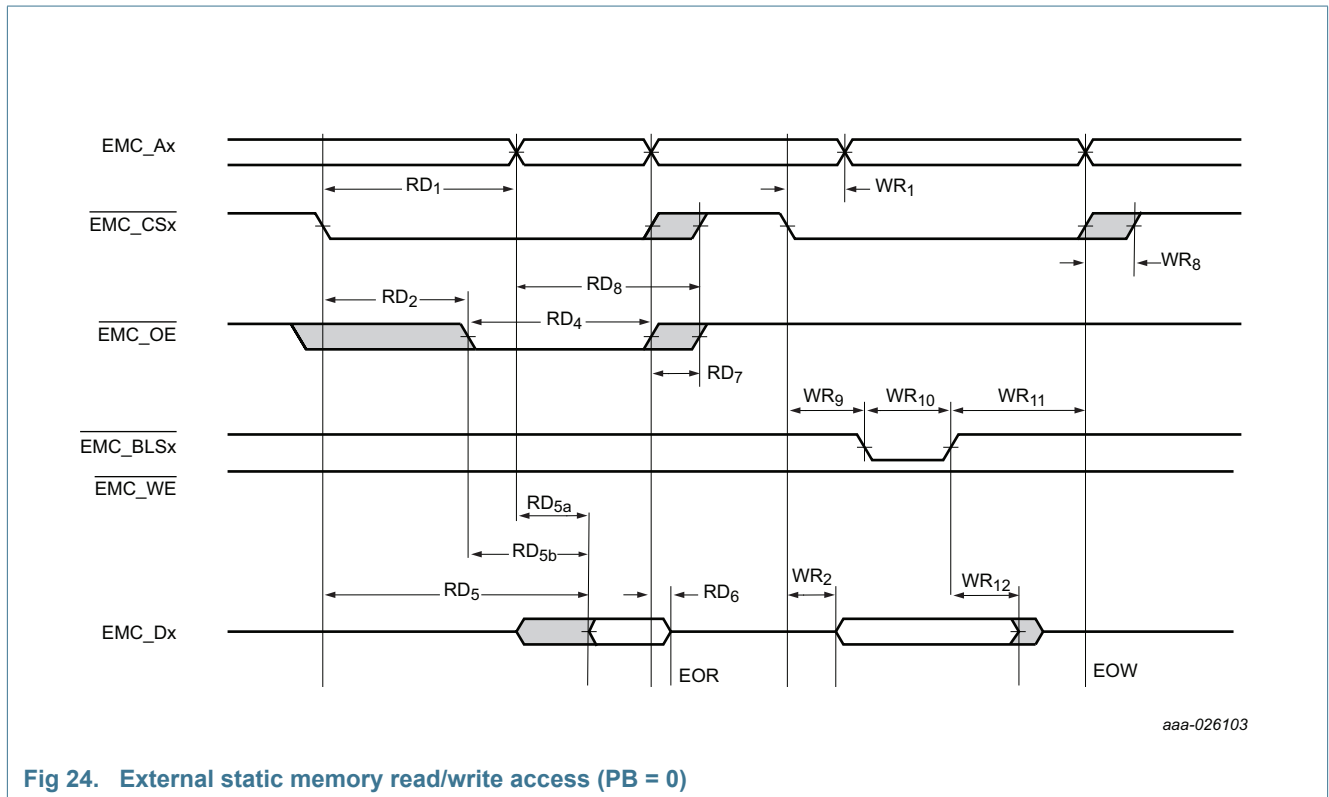

Fig 24. External static memory read/write access (PB = 0)

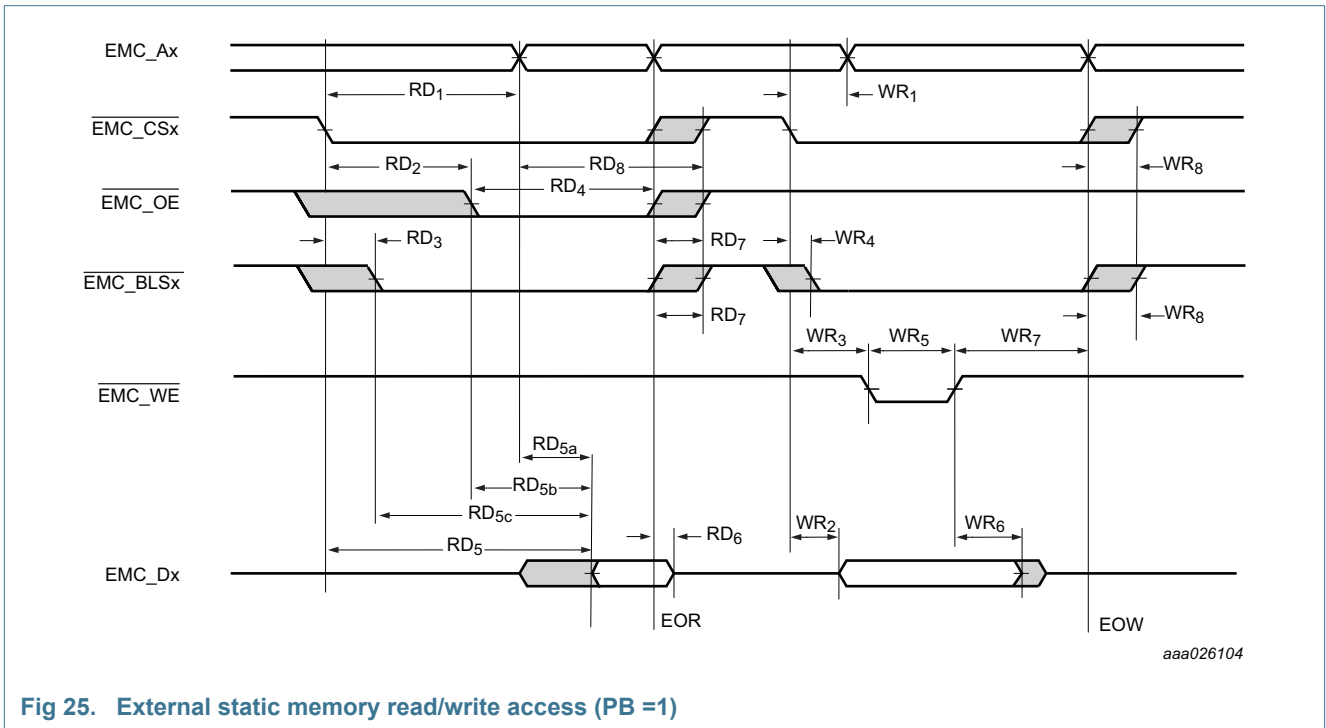

Fig 25. External static memory read/write access (PB = 1)

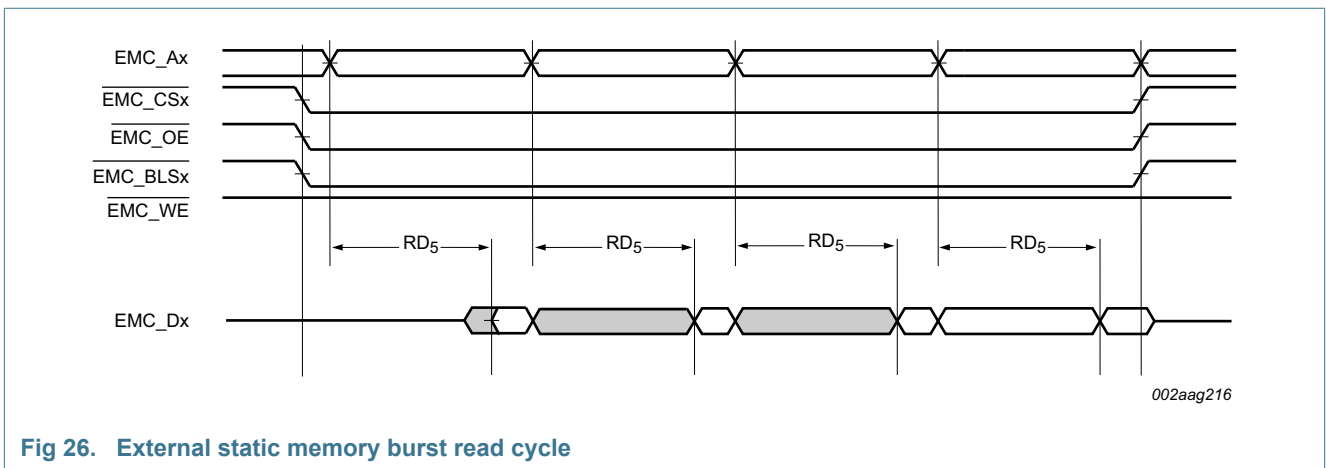

Fig 26. External static memory burst read cycle

Table 28. Dynamic characteristics: Dynamic external memory interface, read strategy bits (RD bits) = 01 [2]

$C_L = 10$ pF balanced loading on all pins, $T_{amb} = -40$ °C to 105 °C, $V_{DD} = 2.7$ V to 3.6 V. Max EMC clock = 100 MHz. Input slew = 1 ns; SLEW set to fast-mode. Parameters sampled at the 90 % and 10 % level of the rising or falling edge. Excluding delays introduced by external device and PCB. Values based on simulation. t_{cmdly} is programmable delay value for EMC command outputs in command delayed mode; t_{fdbly} is programmable delay value for the feedback clock that controls input data sampling.

Symbol	Parameter	Min	Typ	Max	Unit
For RD = 1					
Common to read and write cycles					
$T_{cy}(clk)$	clock cycle time	[1] 10	-	-	ns
$t_{d(SV)}$	chip select valid delay time	-	-	$t_{cmdly} + 3.7$	ns
$t_{h(S)}$	chip select hold time	$t_{cmdly} + 1.7$	-	-	ns
$t_{d(RASV)}$	row address strobe valid delay time	-	-	$t_{cmdly} + 4.1$	ns
$t_{h(RAS)}$	row address strobe hold time	$t_{cmdly} + 1.8$	-	-	ns
$t_{d(CASV)}$	column address strobe valid delay time	-	-	$t_{cmdly} + 4.4$	ns
$t_{h(CAS)}$	column address strobe hold time	$t_{cmdly} + 1.9$	-	-	ns
$t_{d(WV)}$	write valid delay time	-	-	$t_{cmdly} + 5.1$	ns
$t_{h(W)}$	write hold time	$t_{cmdly} + 2.4$	-	-	ns
$t_{d(AV)}$	address valid delay time	-	-	$t_{cmdly} + 4.8$	ns
$t_{h(A)}$	address hold time	$t_{cmdly} + 1.7$	-	-	ns
Read cycle parameters					
$t_{su(D)}$	data input set-up time	0.5	-	-	ns
$t_{h(D)}$	data input hold time	2.1	-	-	ns
Write cycle parameters					
$t_{d(QV)}$	data output valid delay time	-	-	8.1	ns
$t_{h(Q)}$	data output hold time	-1.7	-	-	ns

[1] Refers to SDRAM clock signal EMC_CLKOUTn where n = 0 and 1.

[2] See [Table 30](#) for internal programmable delay.

Table 29. Dynamic characteristics: Dynamic external memory interface, read strategy bits (RD bits) = 01 [2]

$C_L = 20$ pF balanced loading on all pins, $T_{amb} = -40$ °C to 105 °C, $V_{DD} = 2.7$ V to 3.6 V. Max EMC clock = 100 MHz. Input slew = 1 ns; SLEW set to fast-mode. Parameters sampled at the 90 % and 10 % level of the rising or falling edge. Excluding delays introduced by external device and PCB. Values based on simulation. t_{cmdly} is programmable delay value for EMC command outputs in command delayed mode; t_{fbdy} is programmable delay value for the feedback clock that controls input data sampling.

Symbol	Parameter	Min	Typ	Max	Unit
For RD = 1					
Common to read and write cycles					
$T_{cy}(clk)$	clock cycle time	[1] 10	-	-	ns
$t_{d(SV)}$	chip select valid delay time	-	-	$t_{cmdly} + 4.9$	ns
$t_{h(S)}$	chip select hold time	$t_{cmdly} + 2.4$	-	-	ns
$t_{d(RASV)}$	row address strobe valid delay time	-	-	$t_{cmdly} + 5.4$	ns
$t_{h(RAS)}$	row address strobe hold time	$t_{cmdly} + 2.5$	-	-	ns
$t_{d(CASV)}$	column address strobe valid delay time	-	-	$t_{cmdly} + 5.6$	ns
$t_{h(CAS)}$	column address strobe hold time	$t_{cmdly} + 2.6$	-	-	ns
$t_{d(WV)}$	write valid delay time	-	-	$t_{cmdly} + 6.3$	ns
$t_{h(W)}$	write hold time	$t_{cmdly} + 3.1$	-	-	ns
$t_{d(AV)}$	address valid delay time	-	-	$t_{cmdly} + 6.1$	ns
$t_{h(A)}$	address hold time	$t_{cmdly} + 2.4$	-	-	ns
Read cycle parameters					
$t_{su(D)}$	data input set-up time	0.5	-	-	ns
$t_{h(D)}$	data input hold time	2.1	-	-	ns
Write cycle parameters					
$t_{d(QV)}$	data output valid delay time	-	-	9.3	ns
$t_{h(Q)}$	data output hold time	-2.4	-	-	ns

[1] Refers to SDRAM clock signal EMC_CLKOUTn where n = 0 and 1.

[2] See [Table 30](#) for internal programmable delay.

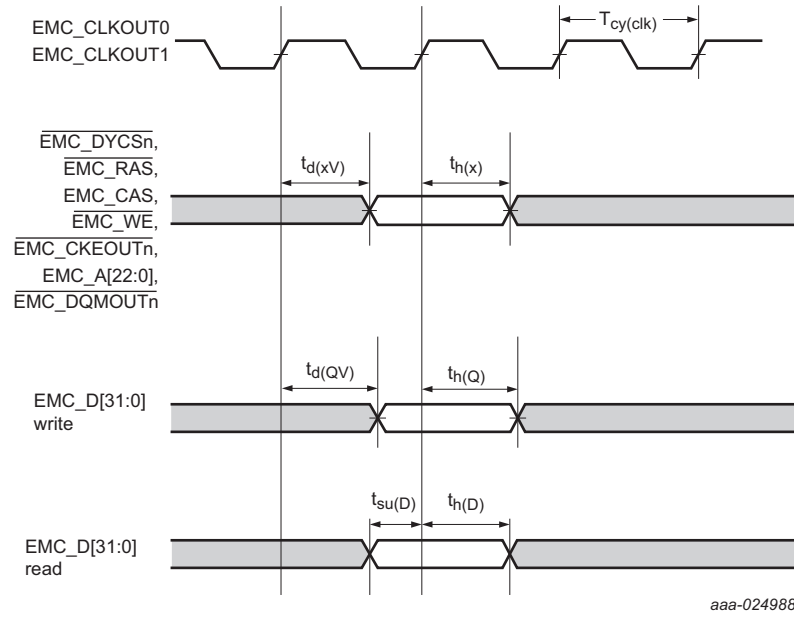

Fig 27. Dynamic external memory interface signal timing

Table 30. Dynamic characteristics: Dynamic external memory interface programmable clock delays (CMDDLY, FBCLKDLY)

$T_{amb} = -40\text{ }^{\circ}\text{C}$ to $105\text{ }^{\circ}\text{C}$, $V_{DD} = 2.7\text{ V}$ to 3.6 V . Values guaranteed by design. t_{cmdly} is programmable delay value for EMC command outputs in command delayed mode; t_{fbdy} is programmable delay value for the feedback clock that controls input data sampling.

Symbols	Parameter	Five bit value for each delay in EMCDLYCTL ^[1]	Min	Typ	Max	Unit
t_{cmdly} , t_{fbdy}	delay time	b00000	0.41	0.66	0.77	ns
		b00001	0.52	0.85	1.03	ns
		b00010	0.69	1.11	1.3	ns
		b00011	0.8	1.3	1.56	ns
		b00100	0.95	1.53	1.77	ns
		b00101	1.06	1.72	2.03	ns
		b00110	1.23	1.98	2.3	ns
		b00111	1.34	2.17	2.56	ns
		b01000	1.45	2.3	2.67	ns
		b01001	1.56	2.49	2.93	ns
		b01010	1.73	2.75	3.2	ns
		b01011	1.84	2.94	3.46	ns
		b01100	1.99	3.17	3.67	ns
		b01101	2.1	3.36	3.93	ns
		b01110	2.27	3.62	4.2	ns
		b01111	2.38	3.81	4.46	ns
		b10000	2.45	3.86	4.46	ns
		b10001	2.56	4.05	4.72	ns
		b10010	2.73	4.31	4.99	ns
		b10011	2.84	4.5	5.25	ns
		b10100	2.99	4.73	5.46	ns
		b10101	3.1	4.92	5.72	ns
		b10110	3.27	5.18	5.99	ns
		b10111	3.38	5.37	6.25	ns
		b11000	3.49	5.5	6.36	ns
		b11001	3.6	5.69	6.62	ns
		b11010	3.77	5.95	6.89	ns
		b11011	3.88	6.14	7.15	ns
		b11100	4.03	6.37	7.36	ns
		b11101	4.14	6.56	7.62	ns
		b11110	4.31	6.82	7.89	ns
		b11111	4.42	7.01	8.15	ns

[1] The programmable delay blocks are controlled by the EMCDLYCTL register in the EMC register block. All delay times are incremental delays for each element starting from delay block 0. See the *LPC546xx. user manual* for details.

11.6 System PLL (PLL0)

Table 31. PLL lock times and current

$T_{amb} = -40\text{ }^{\circ}\text{C}$ to $+105\text{ }^{\circ}\text{C}$, unless otherwise specified. $V_{DD} = 1.71\text{ V}$ to 3.6 V

Symbol	Parameter	Conditions		Min	Typ	Max	Unit
PLL0 configuration: input frequency 12 MHz; output frequency 100 MHz							
$t_{lock(PLL0)}$	PLL0 lock time		[1]			96	μs
$I_{DD(PLL0)}$	PLL0 current	when locked	[1][2]	-	-	2.0	mA
PLL0 configuration: input frequency 32 kHz; output frequency 100 MHz							
$t_{lock(PLL0)}$	PLL0 lock time		[1]	-	-	108	μs
$I_{DD(PLL0)}$	PLL0 current	when locked	[1][2]	-	-	1.6	mA

[1] Data based on characterization results, not tested in production.

[2] PLL current measured using lowest CCO frequency to obtain the desired output frequency.

Table 32. Dynamic characteristics of the PLL0[1]

Symbol	Parameter	Conditions		Min	Typ	Max	Unit
Reference clock input							
F_{in}	input frequency			32.768 kHz	-	25 MHz	
Clock output							
f_o	output frequency	for PLL0 clkout output	[2]	4.3	-	550	MHz
d_o	output duty cycle	for PLL0 clkout output		46	-	54	%
f_{CCO}	CCO frequency			275	-	550	MHz
Lock detector output							
$\Delta_{lock(PFD)}$	PFD lock criterion		[3]	1	2	4	ns
Dynamic parameters at $f_{out} = f_{CCO} = 540\text{ MHz}$; standard bandwidth settings							
$J_{rms-interval}$	RMS interval jitter	$f_{ref} = 10\text{ MHz}$	[4][5]	-	15	30	ps
$J_{pp-period}$	peak-to-peak, period jitter	$f_{ref} = 10\text{ MHz}$	[4][5]	-	40	80	ps

[1] Data based on characterization results, not tested in production.

[2] Excluding under- and overshoot which may occur when the PLL is not in lock.

[3] A phase difference between the inputs of the PFD (clkref and clkfb) smaller than the PFD lock criterion means lock output is HIGH.

[4] Actual jitter dependent on amplitude and spectrum of substrate noise.

[5] Input clock coming from a crystal oscillator with less than 250 ps peak-to-peak period jitter.

11.7 USB PLL (PLL1)

Table 33. PLL1 lock times and current

$T_{amb} = -40\text{ }^{\circ}\text{C}$ to $+105\text{ }^{\circ}\text{C}$, unless otherwise specified. $V_{DD} = 1.71\text{ V}$ to 3.6 V

Symbol	Parameter	Conditions		Min	Typ	Max	Unit
PLL1 configuration: input frequency 12 MHz; output frequency 48 MHz							
$t_{lock(PLL1)}$	PLL1 lock time		[1]	-	7.4	-	μs
$I_{DD(PLL1)}$	PLL1 current	When locked	[1][2]	-	260	-	μA

[1] Data based on characterization results, not tested in production.

[2] PLL current measured using lowest CCO frequency to obtain the desired output frequency.

Table 34. Dynamic characteristics of the PLL1[1]

Symbol	Parameter	Conditions		Min	Typ	Max	Unit
Reference clock input							
F_{in}	input frequency			1	-	25	MHz
Clock output							
f_o	output frequency	for PLL1 clkout output	[2]	9.75	-	160	MHz
d_o	output duty cycle	for PLL1 clkout output		45	-	55	%
f_{CCO}	CCO frequency			156	-	320	MHz
Dynamic parameters at $f_{out} = f_{CCO} = 320\text{ MHz}$; standard bandwidth settings							
$J_{pp\text{-}period}$	peak-to-peak, period jitter	$f_{ref} = 4\text{ MHz}$	[3][4]	-	-	300	ps

[1] Data based on simulation, not tested in production.

[2] Excluding under- and overshoot which may occur when the PLL is not in lock.

[3] Actual jitter dependent on amplitude and spectrum of substrate noise.

[4] Input clock coming from a crystal oscillator with less than 250 ps peak-to-peak period jitter.

11.8 Audio PLL (PLL2)

Table 35. PLL2 lock times and current

$T_{amb} = -40\text{ }^{\circ}\text{C}$ to $+105\text{ }^{\circ}\text{C}$, unless otherwise specified. $V_{DD} = 1.71\text{ V}$ to 3.6 V

Symbol	Parameter	Conditions		Min	Typ	Max	Unit
PLL2 configuration: input frequency 12 MHz; output frequency 100 MHz							
$t_{lock(PLL2)}$	PLL2 lock time		[1]	-	-	96	μs
$I_{DD(PLL2)}$	PLL2 current	when locked	[1][2]	-	-	2.0	mA
PLL2 configuration: input frequency 12 MHz; output frequency 100 MHz							
$t_{lock(PLL2)}$	PLL2 lock time		[1]	-	-	108	μs
$I_{DD(PLL2)}$	PLL2 current	when locked	[1][2]	-	-	1.6	mA

[1] Data based on characterization results, not tested in production.

[2] PLL current measured using lowest CCO frequency to obtain the desired output frequency.

Table 36. Dynamic characteristics of the PLL2^[1]

Symbol	Parameter	Conditions		Min	Typ	Max	Unit
Reference clock input							
F _{in}	input frequency			1	-	25	MHz
Clock output							
f _o	output frequency	for PLL2 clkout output	[2]	4.3	-	550	MHz
d _o	output duty cycle	for PLL2 clkout output		46	-	54	%
f _{CCO}	CCO frequency			275	-	550	MHz
Lock detector output							
Δ _{lock(PFD)}	PFD lock criterion		[3]	1	2	4	ns
Dynamic parameters at f_{out} = f_{CCO} = 540 MHz; standard bandwidth settings							
J _{rms-interval}	RMS interval jitter	f _{ref} = 10 MHz	[4][5]	-	15	30	ps
J _{pp-period}	peak-to-peak, period jitter	f _{ref} = 10 MHz	[4][5]	-	40	80	ps

- [1] Data based on characterization results, not tested in production.
- [2] Excluding under- and overshoot which may occur when the PLL is not in lock.
- [3] A phase difference between the inputs of the PFD (clkref and clkfb) smaller than the PFD lock criterion means lock output is HIGH.
- [4] Actual jitter dependent on amplitude and spectrum of substrate noise.
- [5] Input clock coming from a crystal oscillator with less than 250 ps peak-to-peak period jitter.

11.9 FRO

The FRO is trimmed to ±1 % accuracy over the entire voltage and temperature range.

Table 37. Dynamic characteristic: FRO
T_{amb} = -40 °C to +105 °C; 1.71 V ≤ V_{DD} ≤ 3.6 V.

Symbol	Parameter	Conditions	Min	Typ ^[1]	Max	Unit
f _{osc(RC)}	FRO clock frequency	-	11.88	12	12.12	MHz
f _{osc(RC)}	FRO clock frequency	-	47.52	48	48.48	MHz
f _{osc(RC)}	FRO clock frequency	-	95.04	96	96.96	MHz

- [1] Typical ratings are not guaranteed. The values listed are at room temperature (25 °C), nominal supply voltages.

11.10 Crystal oscillator

Table 38. Dynamic characteristic: oscillator
T_{amb} = -40 °C to +105 °C; 1.71 V ≤ V_{DD} ≤ 3.6 V.^[1]

Symbol	Parameter	Conditions	Min	Typ ^[2]	Max	Unit	
Low-frequency mode (1-20 MHz)^[4]							
t _{jit(per)}	period jitter time	5 MHz crystal	[3]	-	13.2	-	ps
		10 MHz crystal		-	6.6	-	ps
		15 MHz crystal		-	4.8	-	ps

Table 38. Dynamic characteristic: oscillator ...continued

$T_{amb} = -40\text{ }^{\circ}\text{C to } +105\text{ }^{\circ}\text{C}; 1.71\text{ V} \leq V_{DD} \leq 3.6\text{ V}$ ^[1]

Symbol	Parameter	Conditions	Min	Typ ^[2]	Max	Unit	
High-frequency mode (20 - 25 MHz)^[5]							
t _{jit(per)}	period jitter time	20 MHz crystal	[3]	-	4.3	-	ps
		25 MHz crystal		-	3.7	-	ps

[1] Parameters are valid over operating temperature range unless otherwise specified.

[2] Typical ratings are not guaranteed. The values listed are at room temperature (25 °C), nominal supply voltages.

[3] Indicates RMS period jitter.

[4] Select Low Frequency range = 0 in the SYSOSCCTRL register.

[5] Select High Frequency = 1 in the SYSOSCCTRL register.

11.11 RTC oscillator

See [Section 13.5](#) for connecting the RTC oscillator to an external clock source.

Table 39. Dynamic characteristic: RTC oscillator

$T_{amb} = -40\text{ }^{\circ}\text{C to } +105\text{ }^{\circ}\text{C}; 1.71 \leq V_{DD} \leq 3.6$ ^[1]

Symbol	Parameter	Conditions	Min	Typ ^[1]	Max	Unit
f _i	input frequency	-	-	32.768	-	kHz

[1] Parameters are valid over operating temperature range unless otherwise specified.

[2] Typical ratings are not guaranteed. The values listed are at room temperature (25 °C), nominal supply voltages.

11.12 Watchdog oscillator

Table 40. Dynamic characteristics: Watchdog oscillator

$T_{amb} = -40\text{ °C to }+105\text{ °C}; 1.71 \leq V_{DD} \leq 3.6$ ^[1]

Symbol	Parameter	Conditions	Min	Typ ^[1]	Max	Unit
$f_{osc(int)}$	internal watchdog oscillator frequency	[2]	200	-	1500	kHz
D_{clkout}	clkout duty cycle		48	-	52	%
J_{PP-CC}	peak-peak period jitter	[3][4]	-	1	20	ns
t_{start}	start-up time	[4]	-	4	-	μs

[1] Typical ratings are not guaranteed. The values listed are at nominal supply voltages.

[2] The typical frequency spread over processing and temperature ($T_{amb} = -40\text{ °C to }+105\text{ °C}$) is $\pm 40\%$.

[3] Actual jitter dependent on amplitude and spectrum of substrate noise.

[4] Guaranteed by design. Not tested in production samples.

11.13 I²C-busTable 41. Dynamic characteristic: I²C-bus pins^[1] $T_{amb} = -40\text{ }^{\circ}\text{C to } +105\text{ }^{\circ}\text{C}; 1.71\text{ V} \leq V_{DD} \leq 3.6\text{ V.}^{[2]}$

Symbol	Parameter		Conditions	Min	Max	Unit
f _{SCL}	SCL clock frequency		Standard-mode	0	100	kHz
			Fast-mode	0	400	kHz
			Fast-mode Plus	0	1	MHz
t _f	fall time	[4][5][6][7]	Both SDA and SCL signals Standard-mode	-	300	ns
			Fast-mode	20 + 0.1 × C _b	300	ns
			Fast-mode Plus	-	120	ns
t _{LOW}	LOW period of the SCL clock		Standard-mode	4.7	-	μs
			Fast-mode	1.3	-	μs
			Fast-mode Plus	0.5	-	μs
t _{HIGH}	HIGH period of the SCL clock		Standard-mode	4.0	-	μs
			Fast-mode	0.6	-	μs
			Fast-mode Plus	0.26	-	μs
t _{HD;DAT}	data hold time	[3][4][8]	Standard-mode	0	-	μs
			Fast-mode	0	-	μs
			Fast-mode Plus	0	-	μs
t _{SU;DAT}	data set-up time	[9][10]	Standard-mode	250	-	ns
			Fast-mode	100	-	ns
			Fast-mode Plus	50	-	ns

- [1] Guaranteed by design. Not tested in production.
- [2] Parameters are valid over operating temperature range unless otherwise specified. See the I²C-bus specification *UM10204* for details.
- [3] t_{HD;DAT} is the data hold time that is measured from the falling edge of SCL; applies to data in transmission and the acknowledge.
- [4] A device must internally provide a hold time of at least 300 ns for the SDA signal (with respect to the V_{IH(min)} of the SCL signal) to bridge the undefined region of the falling edge of SCL.
- [5] C_b = total capacitance of one bus line in pF. If mixed with Hs-mode devices, faster fall times are allowed.
- [6] The maximum t_f for the SDA and SCL bus lines is specified at 300 ns. The maximum fall time for the SDA output stage t_f is specified at 250 ns. This allows series protection resistors to be connected in between the SDA and the SCL pins and the SDA/SCL bus lines without exceeding the maximum specified t_f.
- [7] In Fast-mode Plus, fall time is specified the same for both output stage and bus timing. If series resistors are used, designers should allow for this when considering bus timing.
- [8] The maximum t_{HD;DAT} could be 3.45 μs and 0.9 μs for Standard-mode and Fast-mode but must be less than the maximum of t_{VD;DAT} or t_{VD;ACK} by a transition time. This maximum must only be met if the device does not stretch the LOW period (t_{LOW}) of the SCL signal. If the clock stretches the SCL, the data must be valid by the set-up time before it releases the clock.
- [9] t_{SU;DAT} is the data set-up time that is measured with respect to the rising edge of SCL; applies to data in transmission and the acknowledge.
- [10] A Fast-mode I²C-bus device can be used in a Standard-mode I²C-bus system but the requirement t_{SU;DAT} = 250 ns must then be met. This will automatically be the case if the device does not stretch the LOW period of the SCL signal. If such a device does stretch the LOW period of the SCL signal, it must output the next data bit to the SDA line t_{r(max)} + t_{SU;DAT} = 1000 + 250 = 1250 ns (according to the Standard-mode I²C-bus specification) before the SCL line is released. Also the acknowledge timing must meet this set-up time.

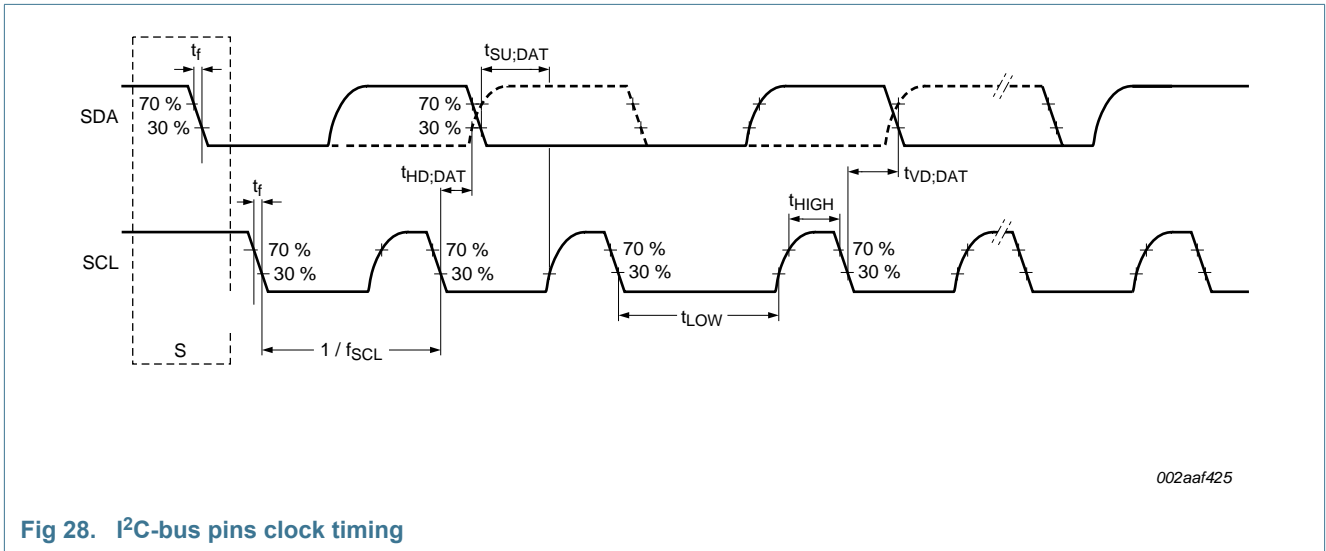

Fig 28. I²C-bus pins clock timing

11.14 I²S-bus interface

Table 42. Dynamic characteristics: I²S-bus interface pins [1][4]

$T_{amb} = -40\text{ }^{\circ}\text{C}$ to $105\text{ }^{\circ}\text{C}$; $V_{DD} = 1.71\text{ V}$ to 3.6 V ; $C_L = 30\text{ pF}$ balanced loading on all pins; Input slew = 1.0 ns , SLEW setting = standard mode for all pins; Parameters sampled at the 50 % level of the rising or falling edge.

Symbol	Parameter	Conditions	Min	Typ ^[3]	Max	Unit	
Common to master and slave							
t_{WH}	pulse width HIGH	on pins I2Sx_TX_SCK and I2Sx_RX_SCK ^[5]					
		CCLK \leq 100 MHz	($T_{cyc}/2$)-1	-	($T_{cyc}/2$)+1	ns	
		100 MHz < CCLK \leq 180 MHz	($T_{cyc}/2$)-1	-	($T_{cyc}/2$)+1	ns	
t_{WL}	pulse width LOW	on pins I2Sx_TX_SCK and I2Sx_RX_SCK ^[5]					
		CCLK \leq 100 MHz	($T_{cyc}/2$)-1	-	($T_{cyc}/2$)+1	ns	
		100 MHz < CCLK \leq 180 MHz	($T_{cyc}/2$)-1	-	($T_{cyc}/2$)+1	ns	
Master; 1.71 V \leq VDD < 2.7 V							
$t_{v(Q)}$	data output valid time	on pin I2Sx_TX_SDA ^[2]					
		CCLK \leq 100 MHz	26.0	-	40.3	ns	
		100 MHz < CCLK \leq 180 MHz	25.0	-	39.0	ns	
		on pin I2Sx_WS					
		CCLK \leq 100 MHz	26.0	-	41.0	ns	
$t_{su(D)}$	data input set-up time	on pin I2Sx_RX_SDA ^[2]					
		CCLK \leq 100 MHz	0	-	-	ns	
		100 MHz < CCLK \leq 180 MHz	0	-	-	ns	
		on pin I2Sx_WS					
		CCLK \leq 100 MHz	0	-	-	ns	
$t_{h(D)}$	data input hold time	on pin I2Sx_RX_SDA ^[2]					
		CCLK \leq 100 MHz	6.1	-	-	ns	
		100 MHz < CCLK \leq 180 MHz	6.4	-	-	ns	
		on pin I2Sx_WS					
		CCLK \leq 100 MHz	3.2	-	-	ns	
Slave; 1.71 V \leq VDD < 2.7 V							
$t_{v(Q)}$	data output valid time	on pin I2Sx_TX_SDA ^[2]					
		CCLK \leq 100 MHz	18.8	-	37.1	ns	
		100 MHz < CCLK \leq 180 MHz	18.0	-	35.5	ns	
$t_{su(D)}$	data input set-up time	on pin I2Sx_RX_SDA ^[2]					
		CCLK \leq 100 MHz	4.8	-	-	ns	
		100 MHz < CCLK \leq 180 MHz	4.4	-	-	ns	
		on pin I2Sx_WS					
		CCLK \leq 100 MHz	0	-	-	ns	
$t_{h(D)}$	data input hold time	on pin I2Sx_RX_SDA ^[2]					
		CCLK \leq 100 MHz	0	-	-	ns	
		100 MHz < CCLK \leq 180 MHz	0	-	-	ns	
		on pin I2Sx_WS					
		CCLK \leq 100 MHz	3.2	-	-	ns	
		100 MHz < CCLK \leq 180 MHz	3.2	-	-	ns	

Table 42. Dynamic characteristics: I²S-bus interface pins [1][4]

$T_{amb} = -40\text{ °C to }105\text{ °C}$; $V_{DD} = 1.71\text{ V to }3.6\text{ V}$; $C_L = 30\text{ pF}$ balanced loading on all pins; Input slew = 1.0 ns, SLEW setting = standard mode for all pins; Parameters sampled at the 50 % level of the rising or falling edge.

Symbol	Parameter	Conditions	Min	Typ ^[3]	Max	Unit
Master; 2.7 V ≤ VDD ≤ 3.6 V						
$t_{v(Q)}$	data output valid time	on pin I2Sx_TX_SDA ^[2]				
		CCLK ≤ 100 MHz	21.4	-	30.4	ns
		100 MHz < CCLK ≤ 180 MHz	20.6	-	28.7	ns
		on pin I2Sx_WS				
		CCLK ≤ 100 MHz	21.1	-	29	ns
		100 MHz < CCLK ≤ 180 MHz	20.3	-	28.3	ns
$t_{su(D)}$	data input set-up time	on pin I2Sx_RX_SDA ^[2]				
		CCLK ≤ 100 MHz	1.3	-	-	ns
		100 MHz < CCLK ≤ 180 MHz	1.0	-	-	ns
$t_{h(D)}$	data input hold time	on pin I2Sx_RX_SDA ^[2]				
		CCLK ≤ 100 MHz	2.9	-	-	ns
		100 MHz < CCLK ≤ 180 MHz	3.3	-	-	ns
Slave; 2.7 V ≤ VDD ≤ 3.6 V						
$t_{v(Q)}$	data output valid time	on pin I2Sx_TX_SDA ^[2]				
		CCLK ≤ 100 MHz	13.8	-	23.6	ns
		100 MHz < CCLK ≤ 180 MHz	13	-	21.9	ns
$t_{su(D)}$	data input set-up time	on pin I2Sx_RX_SDA ^[2]				
		CCLK ≤ 100 MHz	4.7	-	-	ns
		100 MHz < CCLK ≤ 180 MHz	4.2	-	-	ns
		on pin I2Sx_WS				
		CCLK ≤ 100 MHz	0.9	-	-	ns
		100 MHz < CCLK ≤ 180 MHz	0.7	-	-	ns
$t_{h(D)}$	data input hold time	on pin I2Sx_RX_SDA ^[2]				
		CCLK ≤ 100 MHz	0	-	-	ns
		100 MHz < CCLK ≤ 180 MHz	0	-	-	ns
		on pin I2Sx_WS				
		CCLK ≤ 100 MHz	1.5	-	-	ns
		100 MHz < CCLK ≤ 180 MHz	1.3	-	-	ns

- [1] Based on characterization; not tested in production.
- [2] Clock Divider register (DIV) = 0x0.
- [3] Typical ratings are not guaranteed.
- [4] The Flexcomm Interface function clock frequency should not be above 48 MHz. See the data rates section in the I²S chapter (UM10912) to calculate clock and sample rates.
- [5] Based on simulation. Not tested in production.

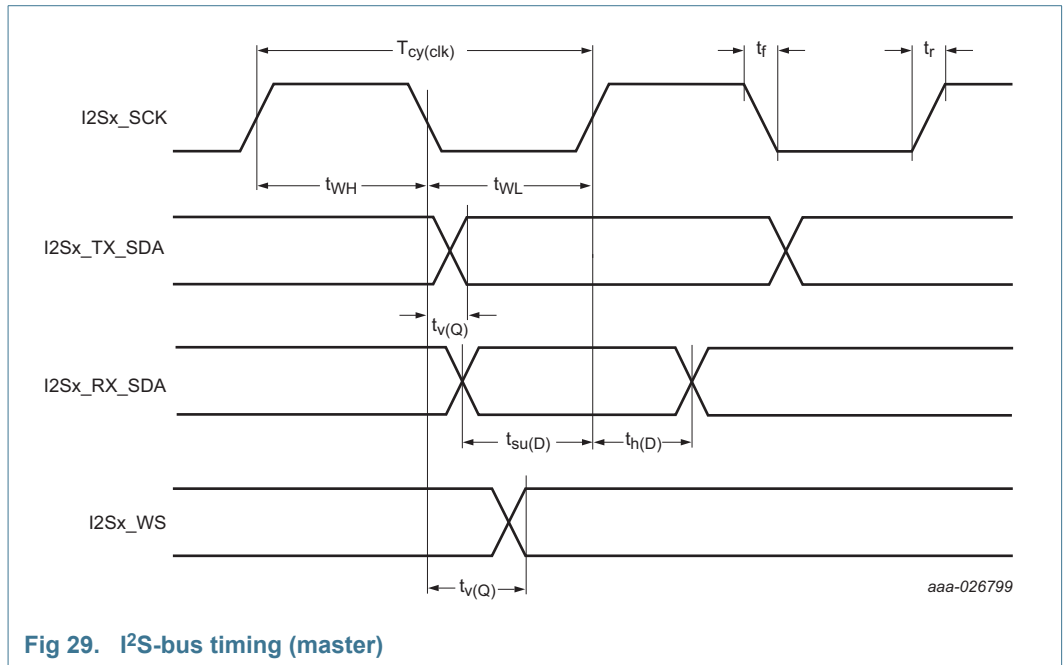

Fig 29. I²S-bus timing (master)

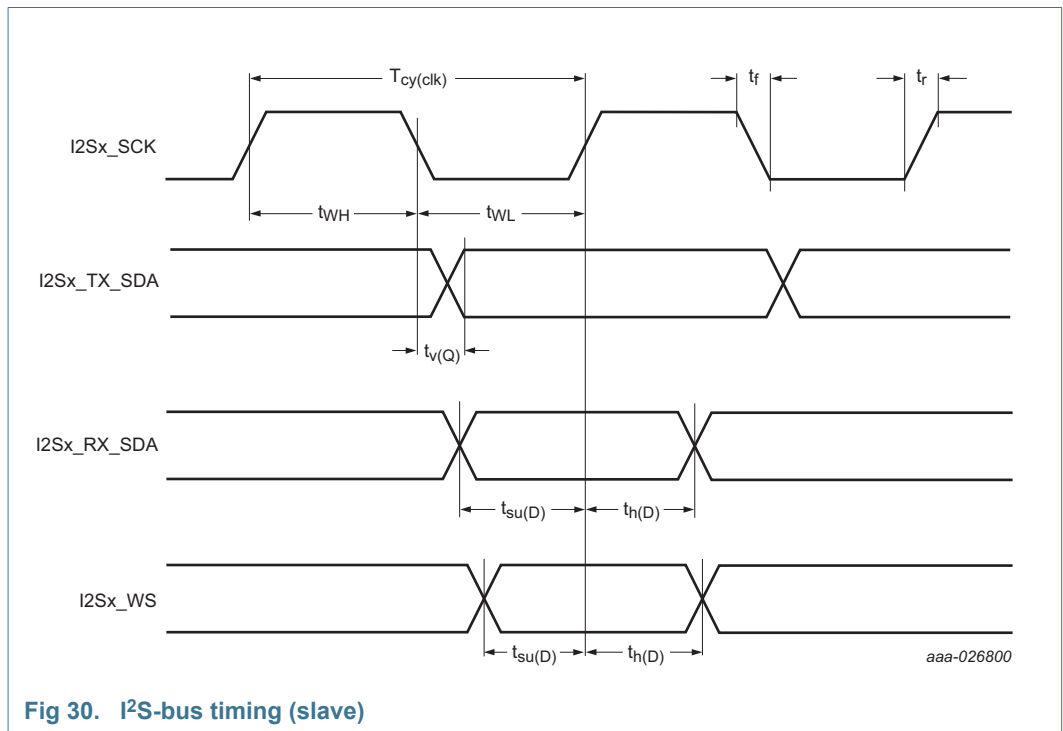

Fig 30. I²S-bus timing (slave)

11.15 SPI interfaces

The actual SPI bit rate depends on the delays introduced by the external trace, the external device, system clock (CCLK), and capacitive loading. Excluding delays introduced by external device and PCB, the maximum supported bit rate for SPI master mode is 48 Mbit/s, and the maximum supported bit rate for SPI slave mode is 14 Mbit/s.

Table 43. SPI dynamic characteristics^[1]

$T_{amb} = -40\text{ }^{\circ}\text{C}$ to $105\text{ }^{\circ}\text{C}$; $1.71\text{ V} \leq V_{DD} \leq 3.6\text{ V}$; $C_L = 30\text{ pF}$ balanced loading on all pins; Input slew = 1 ns, SLEW setting = standard mode for all pins;. Parameters sampled at the 50 % level of the rising or falling edge.

Symbol	Parameter	Conditions	Min	Typ	Max	Unit
SPI master $1.71\text{ V} \leq V_{DD} \leq 2.7\text{ V}$						
t_{DS}	data set-up time	$CCLK \leq 100\text{ MHz}$	2.2	-	-	ns
		$100\text{ MHz} < CCLK \leq 180\text{ MHz}$	1.9	-	-	ns
t_{DH}	data hold time	$CCLK \leq 100\text{ MHz}$	6.3	-	-	ns
		$100\text{ MHz} < CCLK \leq 180\text{ MHz}$	6.7	-	-	ns
$t_{V(Q)}$	data output valid time	$CCLK \leq 100\text{ MHz}$	2.6	-	5.0	ns
		$100\text{ MHz} < CCLK \leq 180\text{ MHz}$	0.3	-	4.7	ns
SPI slave $1.71\text{ V} \leq V_{DD} \leq 2.7\text{ V}$						
t_{DS}	data set-up time	$CCLK \leq 100\text{ MHz}$	1.1	-	-	ns
		$100\text{ MHz} < CCLK \leq 180\text{ MHz}$	0.9	-	-	ns
t_{DH}	data hold time	$CCLK \leq 100\text{ MHz}$	2.1	-	-	ns
		$100\text{ MHz} < CCLK \leq 180\text{ MHz}$	2.2	-	-	ns
$t_{V(Q)}$	data output valid time	$CCLK \leq 100\text{ MHz}$	18.8	-	37.0	ns
		$100\text{ MHz} < CCLK \leq 180\text{ MHz}$	18.0	-	36.0	ns
SPI master $2.7\text{ V} \leq V_{DD} \leq 3.6\text{ V}$						
t_{DS}	data set-up time	$CCLK \leq 100\text{ MHz}$	2.4	-	-	ns
		$100\text{ MHz} < CCLK \leq 180\text{ MHz}$	2.2	-	-	ns
t_{DH}	data hold time	$CCLK \leq 100\text{ MHz}$	4.2	-	-	ns
		$100\text{ MHz} < CCLK \leq 180\text{ MHz}$	4.5	-	-	ns
$t_{V(Q)}$	data output valid time	$CCLK \leq 100\text{ MHz}$	1.8	-	4.6	ns
		$100\text{ MHz} < CCLK \leq 180\text{ MHz}$	1.7	-	4.0	ns
SPI slave $2.7\text{ V} \leq V_{DD} \leq 3.6\text{ V}$						
t_{DS}	data set-up time	$CCLK \leq 100\text{ MHz}$	1.2	-	-	ns
		$100\text{ MHz} < CCLK \leq 180\text{ MHz}$	1.0	-	-	ns
t_{DH}	data hold time	$CCLK \leq 100\text{ MHz}$	0	-	-	ns
		$100\text{ MHz} < CCLK \leq 180\text{ MHz}$	0	-	-	ns
$t_{V(Q)}$	data output valid time	$CCLK \leq 100\text{ MHz}$	14	-	23.9	ns
		$100\text{ MHz} < CCLK \leq 180\text{ MHz}$	13.3	-	22.2	ns

[1] Based on characterization; not tested in production.

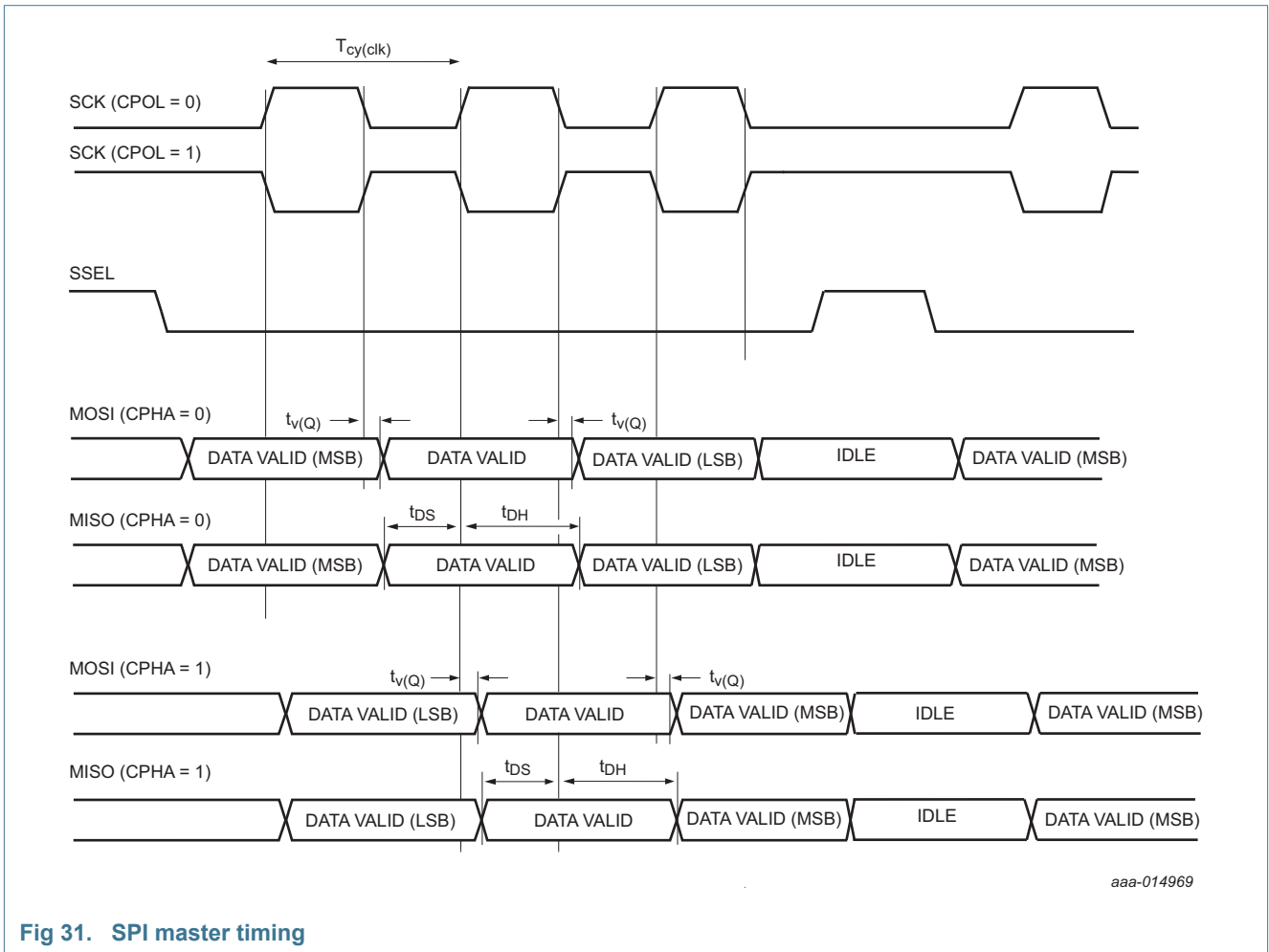

Fig 31. SPI master timing

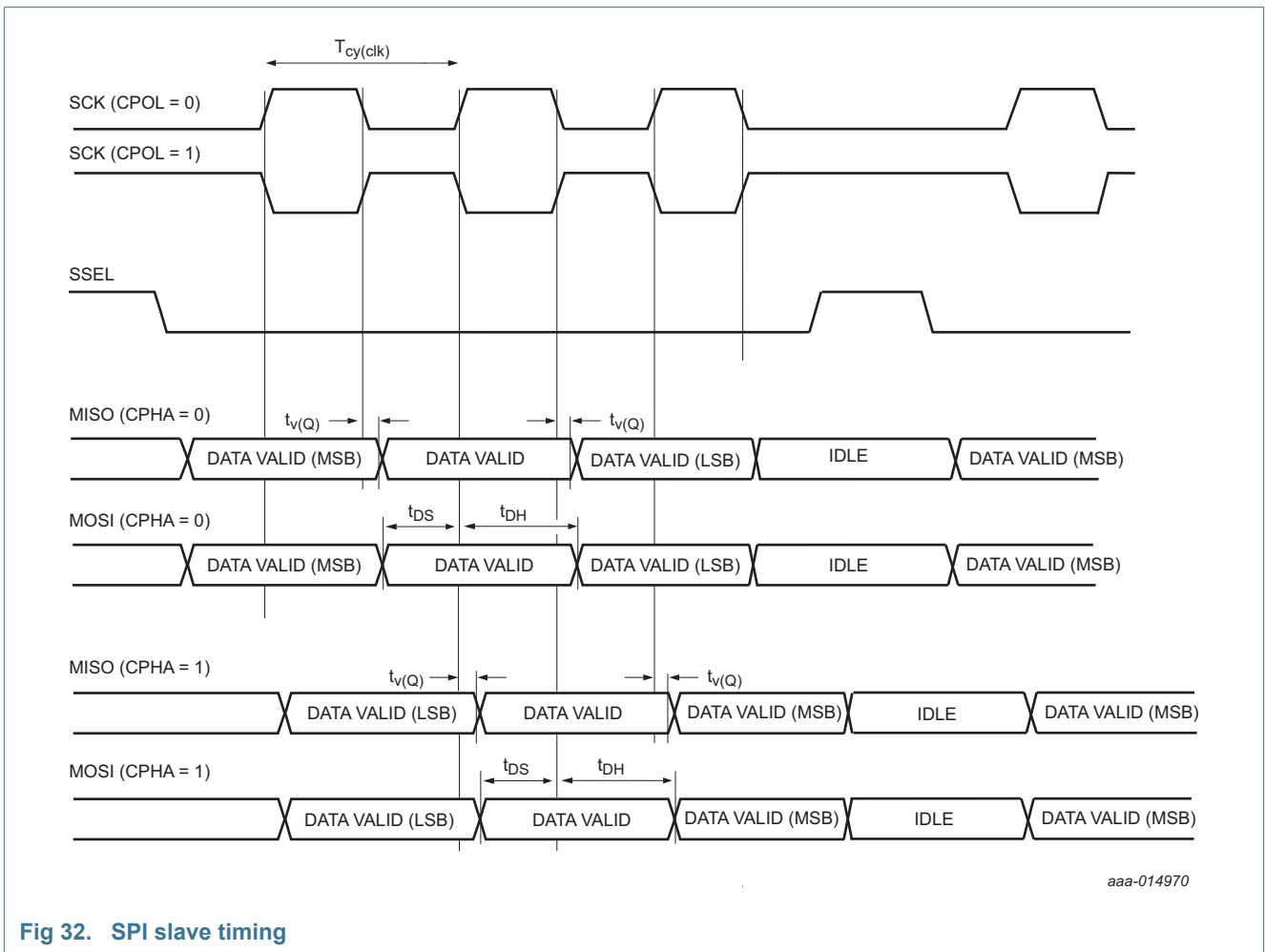

Fig 32. SPI slave timing

11.16 SPIFI

The actual SPIFI bit rate depends on the delays introduced by the external trace, the external device, system clock (CCLK), and capacitive loading. Excluding delays introduced by external device and PCB, the maximum supported bit rate for SPIFI mode is 100 Mbit/s.

Table 44. Dynamic characteristics: SPIFI^[1]

$T_{amb} = -40\text{ }^{\circ}\text{C to }105\text{ }^{\circ}\text{C}$; $V_{DD} = 1.71\text{ V to }3.6\text{ V}$; $C_L = 30\text{ pF}$ balanced loading on all pins; Input slew = 1 ns, SLEW set to standard mode for all pins; Parameters sampled at the 50 % level of the rising or falling edge. Maximum SPIFI clock = 100 MHz

Symbol	Parameter	Conditions	Min	Typ	Max	Unit
SPIFI 1.71 V ≤ VDD ≤ 2.7 V						
t _{DS}	data set-up time	CCLK ≤ 100 MHz	4	-	-	ns
		100 MHz < CCLK ≤ 180 MHz	4	-	-	ns
t _{DH}	data hold time	CCLK ≤ 100 MHz	6.4	-	-	ns
		100 MHz < CCLK ≤ 180 MHz	6.6	-	-	ns
t _{v(Q)}	data output valid time	CCLK ≤ 100 MHz	5.7	-	13.7	ns
		100 MHz < CCLK ≤ 180 MHz	5.7	-	13.7	ns
SPIFI 2.7 V ≤ VDD ≤ 3.6 V						
t _{DS}	data set-up time	CCLK ≤ 100 MHz	4	-	-	ns
		100 MHz < CCLK ≤ 180 MHz	4	-	-	ns
t _{DH}	data hold time	CCLK ≤ 100 MHz	3.5	-	-	ns
		100 MHz < CCLK ≤ 180 MHz	3.6	-	-	ns
t _{v(Q)}	data output valid time	CCLK ≤ 100 MHz	3.3	-	11.5	ns
		100 MHz < CCLK ≤ 180 MHz	3.3	-	11.5	ns

[1] Based on simulation; not tested in production.

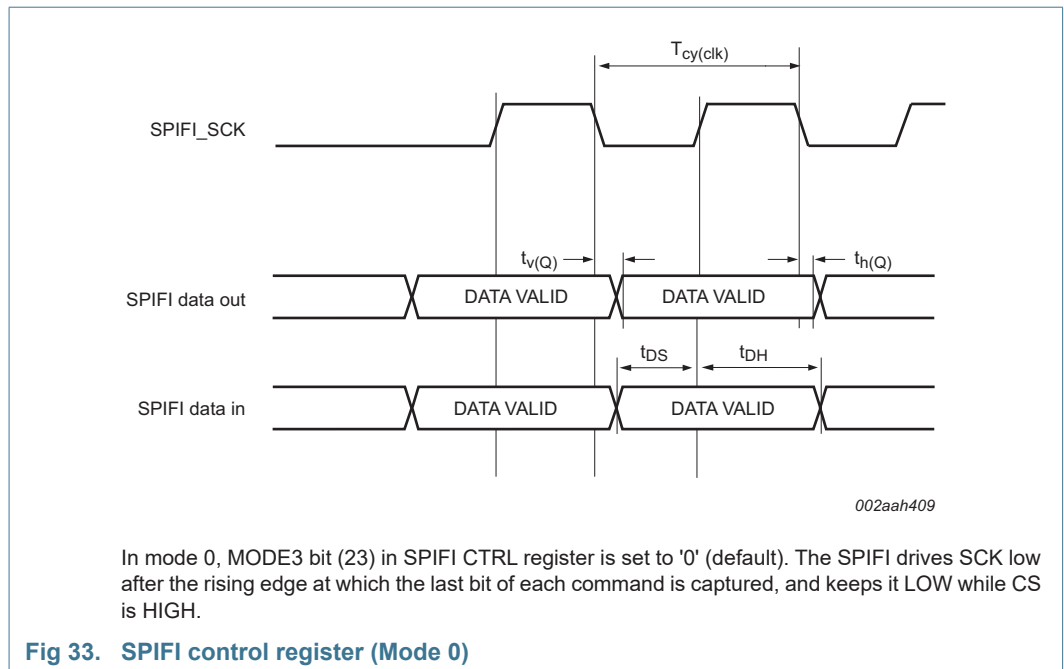

11.17 DMIC subsystem

Table 45. Dynamic characteristics^[1]

$T_{amb} = -40\text{ }^{\circ}\text{C}$ to $105\text{ }^{\circ}\text{C}$; $V_{DD} = 2.7\text{ V}$ to 3.6 V ; $C_L = 30\text{ pF}$ balanced loading on all pins; Input slew = 1 ns , SLEW set to standard mode for all pins; Bypass bit = 0; Parameters sampled at the 90 % and 10 % level of the rising or falling edge.

Symbol	Parameter	Conditions	Min	Typ	Max	Unit
t_{DS}	data set-up time	$CCLK \leq 100\text{ MHz}$	14.3	-	-	ns
		$100\text{ MHz} < CCLK \leq 180\text{ MHz}$	14.3	-	-	ns
t_{DH}	data hold time	$CCLK \leq 100\text{ MHz}$	0	-	-	ns
		$100\text{ MHz} < CCLK \leq 180\text{ MHz}$	0	-	-	ns

[1] Based on simulated values.

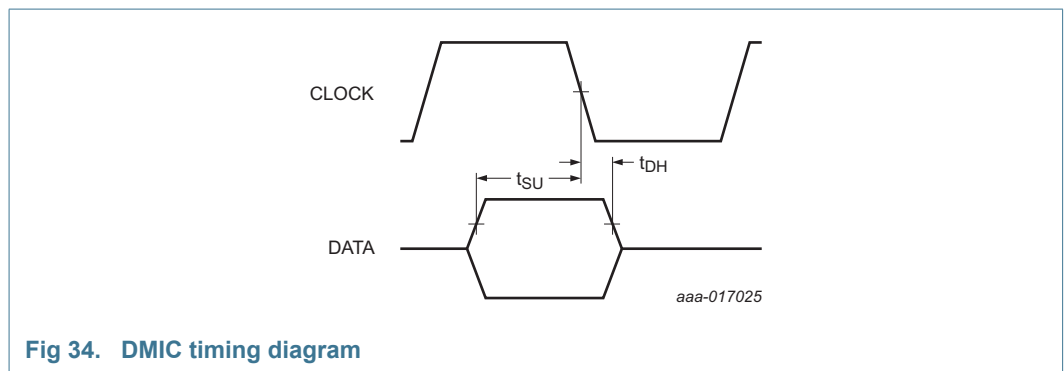

11.18 Smart card interface

Table 46. Dynamic characteristics^[1]

$T_{amb} = -40\text{ }^{\circ}\text{C}$ to $105\text{ }^{\circ}\text{C}$; $V_{DD} = 1.71\text{ V}$ to 3.6 V ; $C_L = 30\text{ pF}$ balanced loading on all pins; Input slew = 1 ns , SLEW setting = standard mode for all pins; Parameters sampled at the 90 % and 10 % level of the rising or falling edge.

Symbol	Parameter	Conditions	Min	Typ	Max	Unit
2.7 V ≤ VDD ≤ 3.6 V						
t _{DS}	data set-up time	CCLK ≤ 100 MHz	2.1	-	-	ns
		100 MHz < CCLK ≤ 180 MHz	2.1	-	-	ns
t _{DH}	data hold time	CCLK ≤ 100 MHz	0	-	-	ns
		100 MHz < CCLK ≤ 180 MHz	0	-	-	ns
t _{V(Q)}	data output valid time	CCLK ≤ 100 MHz	11.0	-	22.5	ns
		100 MHz < CCLK ≤ 180 MHz	11.0	-	22.5	ns

[1] Based on simulated values. $V_{DD} = 2.7\text{ V} - 3.6\text{ V}$.

11.19 USART interface

The actual USART bit rate depends on the delays introduced by the external trace, the external device, system clock (CCLK), and capacitive loading. Excluding delays introduced by external device and PCB, the maximum supported bit rate for USART master synchronous mode is 24 Mbit/s, and the maximum supported bit rate for USART slave synchronous mode is 12.5 Mbit/s.

Table 47. USART dynamic characteristics^[1]

$T_{amb} = -40\text{ }^{\circ}\text{C}$ to $105\text{ }^{\circ}\text{C}$; $V_{DD} = 1.71\text{ V}$ to 3.6 V ; $C_L = 30\text{ pF}$ balanced loading on all pins; Input slew = 1 ns , SLEW setting = standard mode for all pins; Parameters sampled at the 50 % level of the rising or falling edge.

Symbol	Parameter	Conditions	Min	Typ	Max	Unit
USART master (in synchronous mode) $1.71\text{ V} \leq V_{DD} \leq 2.7\text{ V}$						
$t_{su(D)}$	data input set-up time	$CCLK \leq 100\text{ MHz}$	21.2	-	-	ns
		$100\text{ MHz} < CCLK \leq 180\text{ MHz}$	19.7	-	-	ns
$t_{h(D)}$	data input hold time	$CCLK \leq 100\text{ MHz}$	0	-	-	ns
		$100\text{ MHz} < CCLK \leq 180\text{ MHz}$	0	-	-	ns
$t_{v(Q)}$	data output valid time	$CCLK \leq 100\text{ MHz}$	0	-	4.9	ns
		$100\text{ MHz} < CCLK \leq 180\text{ MHz}$	0	-	4.5	ns
USART slave (in synchronous mode) $1.71\text{ V} \leq V_{DD} \leq 2.7\text{ V}$						
$t_{su(D)}$	data input set-up time	$CCLK \leq 100\text{ MHz}$	1.7	-	-	ns
		$100\text{ MHz} < CCLK \leq 180\text{ MHz}$	1.5	-	-	ns
$t_{h(D)}$	data input hold time	$CCLK \leq 100\text{ MHz}$	1.2	-	-	ns
		$100\text{ MHz} < CCLK \leq 180\text{ MHz}$	1.4	-	-	ns
$t_{v(Q)}$	data output valid time	$CCLK \leq 100\text{ MHz}$	20.2	-	39.5	ns
		$100\text{ MHz} < CCLK \leq 180\text{ MHz}$	19.3	-	37.7	ns
USART master (in synchronous mode) $2.7\text{ V} \leq V_{DD} \leq 3.6\text{ V}$						
$t_{su(D)}$	data input set-up time	$CCLK \leq 100\text{ MHz}$	20.5	-	-	ns
		$100\text{ MHz} < CCLK \leq 180\text{ MHz}$	18.9	-	-	ns
$t_{h(D)}$	data input hold time	$CCLK \leq 100\text{ MHz}$	0	-	-	ns
		$100\text{ MHz} < CCLK \leq 180\text{ MHz}$	0	-	-	ns
$t_{v(Q)}$	data output valid time	$CCLK \leq 100\text{ MHz}$	1.5	-	3.6	ns
		$100\text{ MHz} < CCLK \leq 180\text{ MHz}$	1.3	-	3.2	ns
USART slave (in synchronous mode) $2.7\text{ V} \leq V_{DD} \leq 3.6\text{ V}$						
$t_{su(D)}$	data input set-up time	$CCLK \leq 100\text{ MHz}$	1.2	-	-	ns
		$100\text{ MHz} < CCLK \leq 180\text{ MHz}$	1	-	-	ns
$t_{h(D)}$	data input hold time	$CCLK \leq 100\text{ MHz}$	0	-	-	ns
		$100\text{ MHz} < CCLK \leq 180\text{ MHz}$	0	-	-	ns
$t_{v(Q)}$	data output valid time	$CCLK \leq 100\text{ MHz}$	15.2	-	26.1	ns
		$100\text{ MHz} < CCLK \leq 180\text{ MHz}$	14.3	-	24.2	ns

[1] Based on characterization; not tested in production.

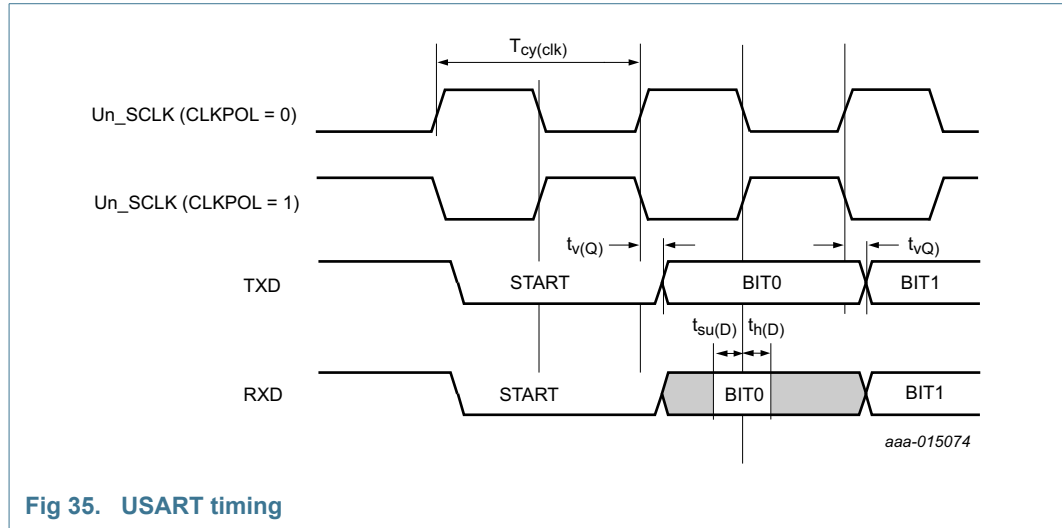

Fig 35. USART timing

11.20 SCTimer/PWM output timing

Table 48. SCTimer/PWM output dynamic characteristics

T_{amb} = -40 °C to 105 °C; 1.71 V ≤ V_{DD} ≤ 3.6 V C_L = 30 pF. Simulated skew (over process, voltage, and temperature) of any two SCT fixed-pin output signals; sampled at the 90 % and 10 % level of the rising or falling edge; values guaranteed by design.

Symbol	Parameter	Conditions	Min	Typ	Max	Unit
t _{sk(o)}	output skew time	-	3.4	-	4.5	ns

11.21 USB interface characteristics

Table 49. Dynamic characteristics: USB0 pins (full-speed)

C_L = 50 pF; R_{pu} = 1.5 kΩ on D+ to V_{DD}, unless otherwise specified; 3.0 V ≤ V_{DD} ≤ 3.6 V.

Symbol	Parameter	Conditions	Min	Typ	Max	Unit
t _r	rise time	10 % to 90 %	4.0		20	ns
t _f	fall time	10 % to 90 %	4.0		20	ns
t _{FRFM}	differential rise and fall time matching	t _r / t _f	90		111.11	%
V _{CRS}	output signal crossover voltage		1.3		2.0	V
t _{FEOPT}	source SE0 interval of EOP	see Figure 36	160		175	ns
t _{FDEOP}	source jitter for differential transition to SE0 transition	see Figure 36	-2		+5	ns
t _{JR1}	receiver jitter to next transition		-18.5		+18.5	ns
t _{JR2}	receiver jitter for paired transitions	10 % to 90 %	-9	-	+9	ns
t _{EOPR1}	EOP width at receiver	must reject as EOP; see Figure 36	[1] 40	-		ns
t _{EOPR2}	EOP width at receiver	must accept as EOP; see Figure 36	[1] 82	-		ns

[1] Characterized but not implemented as production test. Guaranteed by design.

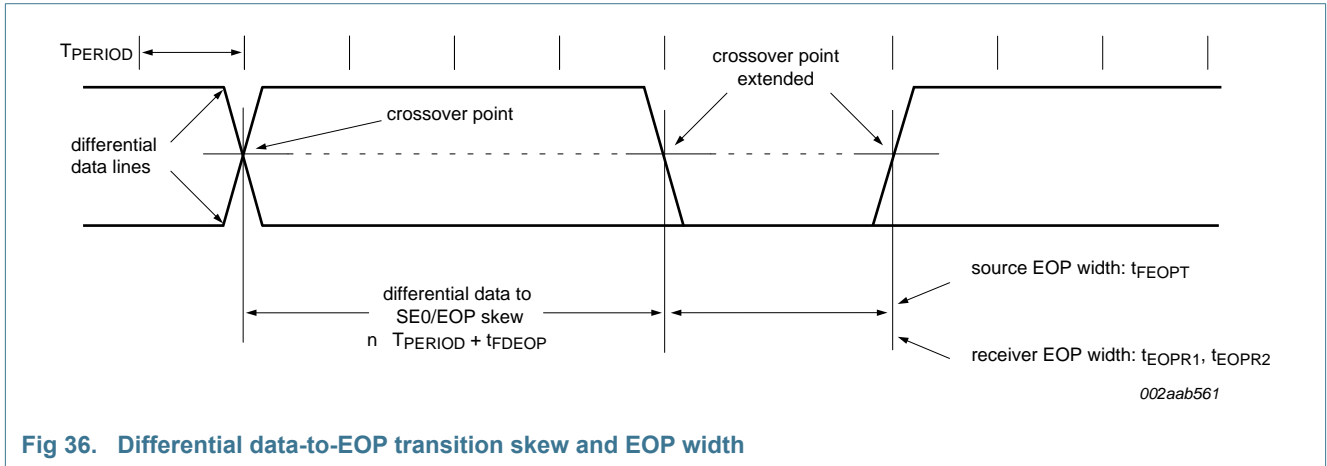

Fig 36. Differential data-to-EOP transition skew and EOP width

11.23 Ethernet AVB

Remark: The timing characteristics of the ENET_MDC and ENET_MDIO signals comply with the *IEEE standard 802.3*.

Table 50. Dynamic characteristics: Ethernet

$T_{amb} = -40\text{ }^{\circ}\text{C}$ to $105\text{ }^{\circ}\text{C}$, $V_{DD} = 2.7\text{ V}$ to 3.6 V . $C_L = 30\text{ pF}$ balanced loading on all pins; Input slew = 1 ns , SLEW setting = standard mode for all pins; Parameters sampled at the 90 % and 10 % level of the rising or falling edge. Based on simulation.

Symbol	Parameter	Conditions	Min	Typ	Max	Unit	
RMII mode							
f_{clk}	clock frequency	for ENET_RX_CLK	[1]	-	-	50.0 MHz	
δ_{clk}	clock duty cycle		[1]	45.0	-	55.0 %	
t_{su}	data input set-up time	ENET_RXDn, ENET_RX_ER, ENET_RX_DV	[1][2]				
		$CCLK \leq 100\text{ MHz}$		4.4	-	-	ns
		$100\text{ MHz} < CCLK \leq 180\text{ MHz}$		4.4	-	-	ns
t_h	data input hold time	for ENET_RXDn, ENET_RX_ER, ENET_RX_DV	[1][2]				
		$CCLK \leq 100\text{ MHz}$		-1.3	-	0	ns
		$100\text{ MHz} < CCLK \leq 180\text{ MHz}$		-1.3	-	0	ns
$t_{v(Q)}$	data output valid time	for ENET_TXDn, ENET_TX_EN	[1][2]				
		$CCLK \leq 100\text{ MHz}$		9.9	-	17.3	ns
		$100\text{ MHz} < CCLK \leq 180\text{ MHz}$		9.9	-	17.3	ns
MII mode							
f_{clk}	clock frequency	for ENET_TX_CLK	[1]	-	-	25.0 MHz	
δ_{clk}	clock duty cycle		[1]	45.0	-	55.0 %	
f_{clk}	clock frequency	for ENET_RX_CLK	[1]	-	-	25.0 MHz	
δ_{clk}	clock duty cycle		[1]	45.0	-	55.0 %	
t_{su}	data input set-up time	for ENET_RXDn, ENET_RX_ER, ENET_RX_DV	[1][2]				
		$CCLK \leq 100\text{ MHz}$		4.7	-	-	ns
		$100\text{ MHz} < CCLK \leq 180\text{ MHz}$		4.7	-	-	ns

Table 50. Dynamic characteristics: Ethernet

$T_{amb} = -40\text{ }^{\circ}\text{C}$ to $105\text{ }^{\circ}\text{C}$, $V_{DD} = 2.7\text{ V}$ to 3.6 V . $C_L = 30\text{ pF}$ balanced loading on all pins; Input slew = 1 ns , SLEW setting = standard mode for all pins; Parameters sampled at the 90 % and 10 % level of the rising or falling edge. Based on simulation.

Symbol	Parameter	Conditions	Min	Typ	Max	Unit	
t_h	data input hold time	for ENET_RXDn, ENET_RX_ER, ENET_RX_DV	[1][2]				
		CCLK \leq 100 MHz		-1.2	-	0	ns
		100 MHz < CCLK \leq 180 MHz		-1.2	-	0	ns
$t_{v(Q)}$	data output valid time	for ENET_TXDn, ENET_TX_EN, ENET_TX_ER	[1][2]				
		CCLK \leq 100 MHz		10.0	-	18.2	ns
		100 MHz < CCLK \leq 180 MHz		10.0	-	18.2	ns

- [1] Output drivers can drive a load $\geq 25\text{ pF}$ accommodating over 12 inch of PCB trace and the input capacitance of the receiving device.
- [2] Timing values are given from the point at which the clock signal waveform crosses 1.4 V to the valid input or output level.

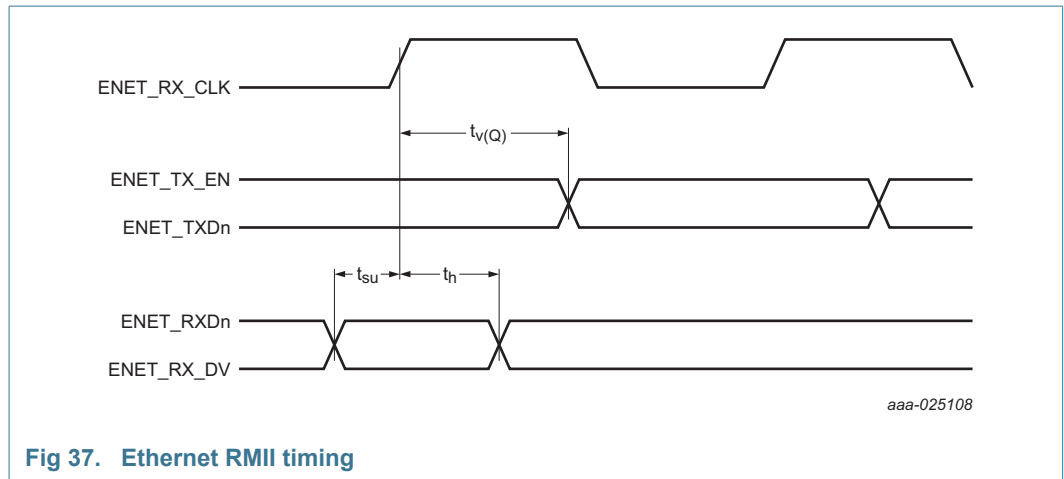

Fig 37. Ethernet RMI timing

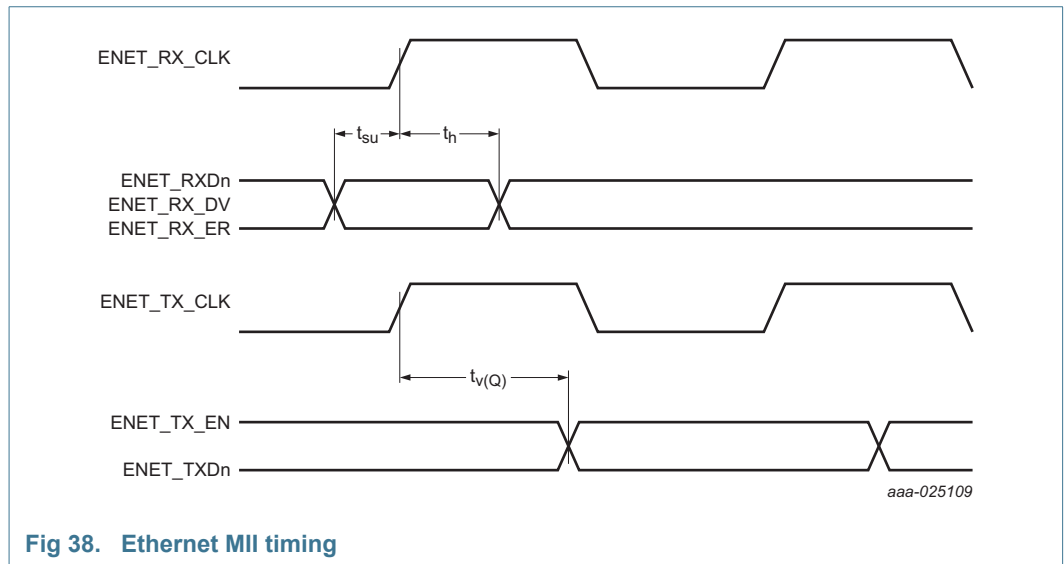

Fig 38. Ethernet MII timing

11.24 SD/MMC and SDIO

Table 51. Dynamic characteristics: SD/MMC and SDIO

$T_{amb} = -40\text{ }^{\circ}\text{C}$ to $+105\text{ }^{\circ}\text{C}$, $V_{DD} = 2.7\text{ V}$ to 3.6 V ; $C_L = 20\text{ pF}$. $SAMPLE_DELAY = 0$, $DRV_DELAY = 0$ in the $SDDELAY$ register, $SDIOCLKCTRL = 0x84$, sampled at 90 % and 10 % of the signal level, $SLEW = 1\text{ ns}$ for SD_CLK pin, $SLEW = 1\text{ ns}$ for SD_DATn and SD_CMD pins. Simulated values in high-speed mode.

Symbol	Parameter	Conditions	Min	Typ	Max	Unit
f_{clk}	clock frequency	on pin SD_CLK ; data transfer mode	-	-	50	MHz
$t_{su(D)}$	data input set-up time	on pins SD_DATn as inputs				
		$CCLK \leq 100\text{ MHz}$	14.4	-	-	ns
		$100\text{ MHz} < CCLK \leq 180\text{ MHz}$	14.4	-	-	ns
		on pins SD_CMD as inputs				
		$CCLK \leq 100\text{ MHz}$	14.4	-	-	ns
		$100\text{ MHz} < CCLK \leq 180\text{ MHz}$	14.4	-	-	ns
$t_{h(D)}$	data input hold time	on pins SD_DATn as inputs				
		$CCLK \leq 100\text{ MHz}$	1.5	-	-	ns
		$100\text{ MHz} < CCLK \leq 180\text{ MHz}$	1.5	-	-	ns
		on pins SD_CMD as inputs				
		$CCLK \leq 100\text{ MHz}$	1.5	-	-	ns
		$100\text{ MHz} < CCLK \leq 180\text{ MHz}$	1.5	-	-	ns
$t_{v(Q)}$	data output valid time	on pins SD_DATn as outputs				
		$CCLK \leq 100\text{ MHz}$	1.9	-	3.5	ns
		$100\text{ MHz} < CCLK \leq 180\text{ MHz}$	1.9	-	3.5	ns
		on pins SD_CMD as outputs				
		$CCLK \leq 100\text{ MHz}$	1.9	-	3.5	ns
		$100\text{ MHz} < CCLK \leq 180\text{ MHz}$	1.9	-	3.5	ns

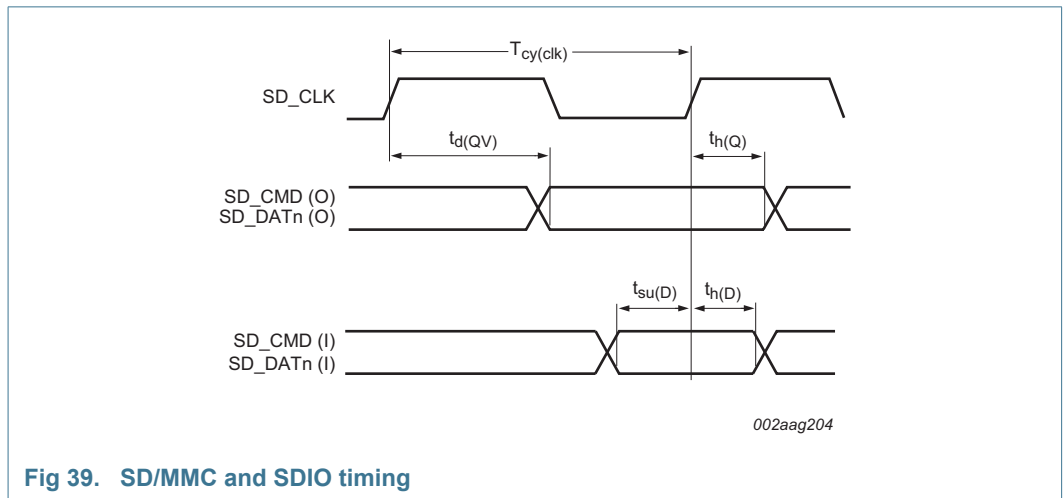

Fig 39. SD/MMC and SDIO timing

11.25 LCD

Table 52. Dynamic characteristics: LCD

$T_{amb} = -40\text{ }^{\circ}\text{C}$ to $105\text{ }^{\circ}\text{C}$; $V_{DD} = 2.7\text{ V}$ to 3.6 V ; $C_L = 30\text{ pF}$. Simulated values.

Symbol	Parameter	Conditions	Min	Typ	Max	Unit
f_{clk}	clock frequency	on pin LCD_DCLK	-	-	50	MHz
$t_{V(Q)}$	data output valid time on all LCD output pins	$CCLK \leq 100\text{ MHz}$	0.9	-	1.6	ns
		$100\text{ MHz} < CCLK \leq 180\text{ MHz}$	0.9	-	1.6	ns

12. Analog characteristics

12.1 BOD

Table 53. BOD static characteristics

$T_{amb} = 25\text{ }^{\circ}\text{C}$; based on characterization; not tested in production.

Symbol	Parameter	Conditions	Min	Typ	Max	Unit
V_{th}	threshold voltage	interrupt level 0				
		assertion	1.5	-	1.63	V
		de-assertion	1.55	-	1.69	V
		reset level 0				
		assertion	1.5	-	1.62	V
		de-assertion	1.55	-	1.69	V
V_{th}	threshold voltage	interrupt level 1				
		assertion	1.54	-	1.68	V
		de-assertion	1.6	-	1.75	V
		reset level 1				
		assertion	1.55	-	1.68	V
		de-assertion	1.61	-	1.74	V
V_{th}	threshold voltage	interrupt level 2				
		assertion	1.79	-	1.95	V
		de-assertion	1.85	-	2.02	V
		reset level 2				
		assertion	2.04	-	2.21	V
		de-assertion	2.19	-	2.38	V
V_{th}	threshold voltage	interrupt level 3				
		assertion	2.62	-	2.86	V
		de-assertion	2.77	-	3.03	V
		reset level 3				
		assertion	2.62	-	2.85	V
		de-assertion	2.78	-	3.02	V

12.2 12-bit ADC characteristics

Table 54. 12-bit ADC static characteristics

$T_{amb} = -40\text{ }^{\circ}\text{C}$ to $+105\text{ }^{\circ}\text{C}$; $1.71\text{ V} \leq V_{DD} \leq 3.6\text{ V}$; $V_{SSA} = V_{REFN} = GND$. ADC calibrated at $T_{amb} = 25\text{ }^{\circ}\text{C}$.

Symbol	Parameter	Conditions	Min	Typ ^[2]	Max	Unit
V_{IA}	analog input voltage		[3] 0	-	V_{DDA}	V
C_{ia}	analog input capacitance		[4] -	5.0	-	pF
$f_{clk(ADC)}$	ADC clock frequency			-	80	MHz
f_s	sampling frequency		-	-	5.0	Msamples/s
E_D	differential linearity error	$2.0\text{ V} < V_{DDA} \leq 3.6\text{ V}$ $2.0\text{ V} < V_{REFP} \leq 3.6\text{ V}$ $f_{clk(ADC)} = 80\text{ MHz}$	[1][5] -	$< \pm 3.0$	-	LSB
		$1.71\text{ V} \leq V_{DDA} \leq 2.0\text{ V}$ $1.71\text{ V} \leq V_{REFP} \leq 2.0\text{ V}$ $f_{clk(ADC)} = 80\text{ MHz}$	[1][5] -	$< \pm 4.5$	-	LSB
			[1][5] -		-	LSB
$E_{L(adj)}$	integral non-linearity	$2.0\text{ V} < V_{DDA} \leq 3.6\text{ V}$ $2.0\text{ V} < V_{REFP} \leq 3.6\text{ V}$ $f_{clk(ADC)} = 80\text{ MHz}$	[1][6] -	$< \pm 4.0$	-	LSB
		$1.71\text{ V} \leq V_{DDA} \leq 2.0\text{ V}$ $1.71\text{ V} \leq V_{REFP} \leq 2.0\text{ V}$ $f_{clk(ADC)} = 80\text{ MHz}$	[1][6] -	$< \pm 7.5$	-	LSB
			[1][6] -		-	LSB
E_O	offset error	calibration enabled	[1][7] -	$< \pm 2.2$	-	mV
$V_{err(FS)}$	full-scale error voltage	$2.0\text{ V} < V_{DDA} \leq 3.6\text{ V}$ $2.0\text{ V} < V_{REFP} \leq 3.6\text{ V}$ $f_{clk(ADC)} = 80\text{ MHz}$	[1][8] -	$< \pm 3.0$	-	LSB
		$1.71\text{ V} \leq V_{DDA} \leq 2.0\text{ V}$ $1.71\text{ V} \leq V_{REFP} \leq 2.0\text{ V}$ $f_{clk(ADC)} = 80\text{ MHz}$	-	$< \pm 2.5$	-	LSB
Z_i	input impedance	$f_s = 5.0\text{ Msamples/s}$	[9][10] 17.0	-	-	k Ω

- [1] Based on characterization; not tested in production.
- [2] Typical ratings are not guaranteed. The values listed are at room temperature (25 °C), nominal supply voltages.
- [3] The input resistance of ADC channels 6 to 11 is higher than ADC channels 0 to 5.
- [4] C_{ia} represents the external capacitance on the analog input channel for sampling speeds of 5.0 Msamples/s. No parasitic capacitances included.
- [5] The differential linearity error (E_D) is the difference between the actual step width and the ideal step width. See [Figure 40](#).
- [6] The integral non-linearity ($E_{L(adj)}$) is the peak difference between the center of the steps of the actual and the ideal transfer curve after appropriate adjustment of gain and offset errors. See [Figure 40](#).
- [7] The offset error (E_O) is the absolute difference between the straight line which fits the actual curve and the straight line which fits the ideal curve. See [Figure 40](#).

- [8] The full-scale error voltage or gain error (E_G) is the difference between the straight-line fitting the actual transfer curve after removing offset error, and the straight line which fits the ideal transfer curve. See [Figure 40](#).
- [9] $T_{amb} = 25\text{ }^\circ\text{C}$; maximum sampling frequency $f_s = 5.0\text{ Msamples/s}$ and analog input capacitance $C_{ia} = 5\text{ pF}$.
- [10] Input impedance Z_i is inversely proportional to the sampling frequency and the total input capacity including C_{ia} and C_{io} : $Z_i \propto 1 / (f_s \times C_i)$. See [Table 21](#) for C_{io} . See [Figure 41](#).

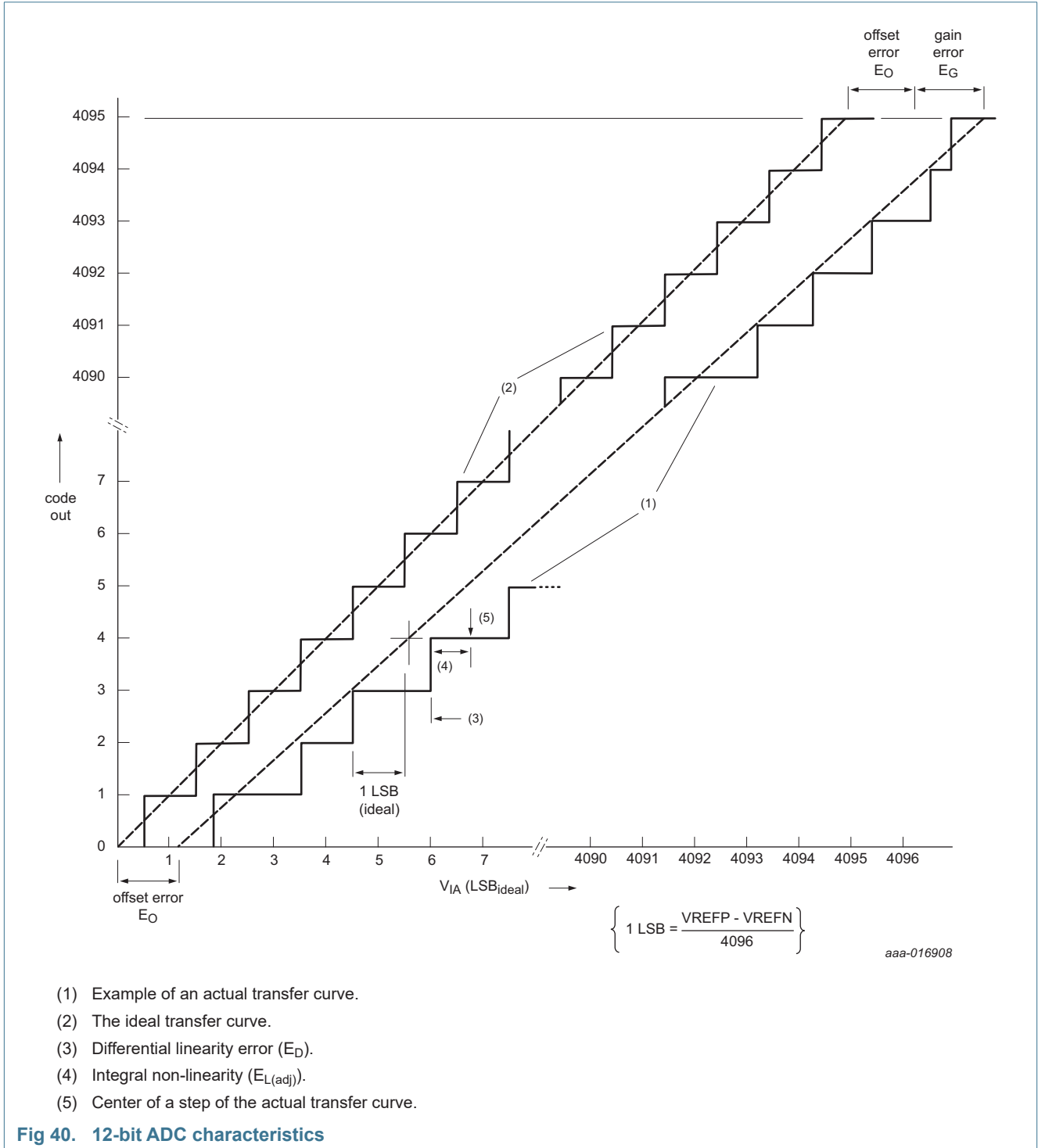

Table 55. ADC sampling times^[1]-40 °C ≤ T_{amb} ≤ 85 °C; 1.71 V ≤ V_{DDA} ≤ 3.6 V; 1.71 V ≤ V_{DD} ≤ 3.6 V

Symbol	Parameter	Conditions	Min	Typ	Max	Unit	
ADC inputs ADC_5 to ADC_0 (fast channels); ADC resolution = 12 bit							
t _s	sampling time	Z _o < 0.05 kΩ	[3]	20	-	-	ns
		0.05 kΩ ≤ Z _o < 0.1 kΩ		23	-	-	ns
		0.1 kΩ ≤ Z _o < 0.2 kΩ		26	-	-	ns
		0.2 kΩ ≤ Z _o < 0.5 kΩ		31	-	-	ns
		0.5 kΩ ≤ Z _o < 1 kΩ		47	-	-	ns
		1 kΩ ≤ Z _o < 5 kΩ		75	-	-	ns
ADC inputs ADC_5 to ADC_0 (fast channels); ADC resolution = 10 bit							
t _s	sampling time	Z _o < 0.05 kΩ	[3]	15	-	-	ns
		0.05 kΩ ≤ Z _o < 0.1 kΩ		18	-	-	ns
		0.1 kΩ ≤ Z _o < 0.2 kΩ		20	-	-	ns
		0.2 kΩ ≤ Z _o < 0.5 kΩ		24	-	-	ns
		0.5 kΩ ≤ Z _o < 1 kΩ		38	-	-	ns
		1 kΩ ≤ Z _o < 5 kΩ		62	-	-	ns
ADC inputs ADC_5 to ADC_0 (fast channels); ADC resolution = 8 bit							
t _s	sampling time	Z _o < 0.05 kΩ	[3]	12	-	-	ns
		0.05 kΩ ≤ Z _o < 0.1 kΩ		13	-	-	ns
		0.1 kΩ ≤ Z _o < 0.2 kΩ		15	-	-	ns
		0.2 kΩ ≤ Z _o < 0.5 kΩ		19	-	-	ns
		0.5 kΩ ≤ Z _o < 1 kΩ		30	-	-	ns
		1 kΩ ≤ Z _o < 5 kΩ		48	-	-	ns
ADC inputs ADC_5 to ADC_0 (fast channels); ADC resolution = 6 bit							
t _s	sampling time	Z _o < 0.05 kΩ	[3]	9	-	-	ns
		0.05 kΩ ≤ Z _o < 0.1 kΩ		10	-	-	ns
		0.1 kΩ ≤ Z _o < 0.2 kΩ		11	-	-	ns
		0.2 kΩ ≤ Z _o < 0.5 kΩ		13	-	-	ns
		0.5 kΩ ≤ Z _o < 1 kΩ		22	-	-	ns
		1 kΩ ≤ Z _o < 5 kΩ		36	-	-	ns
ADC inputs ADC_11 to ADC_6 (slow channels); ADC resolution = 12 bit							
t _s	sampling time	Z _o < 0.05 kΩ	[3]	43	-	-	ns
		0.05 kΩ ≤ Z _o < 0.1 kΩ		46	-	-	ns
		0.1 kΩ ≤ Z _o < 0.2 kΩ		50	-	-	ns
		0.2 kΩ ≤ Z _o < 0.5 kΩ		56	-	-	ns
		0.5 kΩ ≤ Z _o < 1 kΩ		74	-	-	ns
		1 kΩ ≤ Z _o < 5 kΩ		105	-	-	ns

Table 55. ADC sampling times^[1] ...continued
 $-40\text{ }^{\circ}\text{C} \leq T_{amb} \leq 85\text{ }^{\circ}\text{C}$; $1.71\text{ V} \leq V_{DDA} \leq 3.6\text{ V}$; $1.71\text{ V} \leq V_{DD} \leq 3.6\text{ V}$

Symbol	Parameter	Conditions	Min	Typ	Max	Unit	
ADC inputs ADC_11 to ADC_6 (slow channels); ADC resolution = 10 bit							
t_s	sampling time	$Z_o < 0.05\text{ k}\Omega$	[3]	35	-	-	ns
		$0.05\text{ k}\Omega \leq Z_o < 0.1\text{ k}\Omega$		38	-	-	ns
		$0.1\text{ k}\Omega \leq Z_o < 0.2\text{ k}\Omega$		40	-	-	ns
		$0.2\text{ k}\Omega \leq Z_o < 0.5\text{ k}\Omega$		46	-	-	ns
		$0.5\text{ k}\Omega \leq Z_o < 1\text{ k}\Omega$		61	-	-	ns
		$1\text{ k}\Omega \leq Z_o < 5\text{ k}\Omega$		86	-	-	ns
ADC inputs ADC_11 to ADC_6 (slow channels); ADC resolution = 8 bit							
t_s	sampling time	$Z_o < 0.05\text{ k}\Omega$	[3]	27	-	-	ns
		$0.05\text{ k}\Omega \leq Z_o < 0.1\text{ k}\Omega$		29	-	-	ns
		$0.1\text{ k}\Omega \leq Z_o < 0.2\text{ k}\Omega$		32	-	-	ns
		$0.2\text{ k}\Omega \leq Z_o < 0.5\text{ k}\Omega$		36	-	-	ns
		$0.5\text{ k}\Omega \leq Z_o < 1\text{ k}\Omega$		48	-	-	ns
		$1\text{ k}\Omega \leq Z_o < 5\text{ k}\Omega$		69	-	-	ns
ADC inputs ADC_11 to ADC_6 (slow channels); ADC resolution = 6 bit							
t_s	sampling time	$Z_o < 0.05\text{ k}\Omega$	[3]	20	-	-	ns
		$0.05\text{ k}\Omega \leq Z_o < 0.1\text{ k}\Omega$		22	-	-	ns
		$0.1\text{ k}\Omega \leq Z_o < 0.2\text{ k}\Omega$		23	-	-	ns
		$0.2\text{ k}\Omega \leq Z_o < 0.5\text{ k}\Omega$		26	-	-	ns
		$0.5\text{ k}\Omega \leq Z_o < 1\text{ k}\Omega$		36	-	-	ns
		$1\text{ k}\Omega \leq Z_o < 5\text{ k}\Omega$		51	-	-	ns

[1] Characterized through simulation. Not tested in production.

[2] The ADC default sampling time is 2.5 ADC clock cycles. To match a given analog source output impedance, the sampling time can be extended by adding up to seven ADC clock cycles for a maximum sampling time of 9.5 ADC clock cycles. See the TSAMP bits in the ADC CTRL register.

[3] Z_o = analog source output impedance.

[4] For $V_{DD} \leq 2.5\text{ V}$, add one additional clock cycle to the values in [Table 55](#).

12.2.1 ADC input impedance

[Figure 41](#) shows the ADC input impedance. In this figure:

- ADCx represents slow ADC input channels 6 to 11.
- ADCy represents fast ADC input channels 0 to 5.
- R_1 and R_{sw} are the switch-on resistance on the ADC input channel.
- If fast channels (ADC inputs 0 to 5) are selected, the ADC input signal goes through R_{sw} to the sampling capacitor (C_{ia}).
- If slow channels (ADC inputs 6 to 11) are selected, the ADC input signal goes through $R_1 + R_{sw}$ to the sampling capacitor (C_{ia}).
- Typical values, $R_1 = 487\ \Omega$, $R_{sw} = 278\ \Omega$
- See [Table 21](#) for C_{io} .
- See [Table 54](#) for C_{ia} .

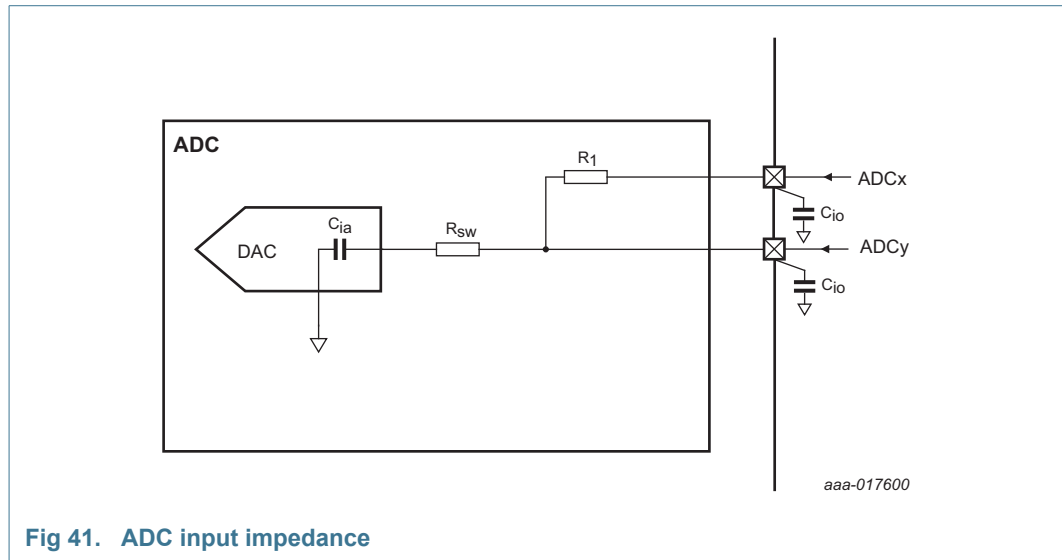

Fig 41. ADC input impedance

12.3 Temperature sensor

Table 56. Temperature sensor static and dynamic characteristics

$V_{DD} = V_{DDA} = 1.71\text{ V to }3.6\text{ V}$

Symbol	Parameter	Conditions		Min	Typ	Max	Unit
DT_{sen}	sensor temperature accuracy	$T_{\text{amb}} = -40\text{ }^{\circ}\text{C to }+105\text{ }^{\circ}\text{C}$	[1]	-		3.7	$^{\circ}\text{C}$
E_L	linearity error	$T_{\text{amb}} = -40\text{ }^{\circ}\text{C to }+105\text{ }^{\circ}\text{C}$		-	-	3.7	$^{\circ}\text{C}$
$t_{\text{s(pu)}}$	power-up settling time	to 99% of temperature sensor output value	[2]	-	10.0	15.0	μs

[1] Absolute temperature accuracy.

[2] Based on simulation.

Table 57. Temperature sensor Linear-Least-Square (LLS) fit parameters

$V_{DD} = V_{DDA} = 1.71\text{ V to }3.6\text{ V}$

Fit parameter	Range		Min	Typ	Max	Unit
LLS slope	$T_{amb} = -40\text{ °C to }+105\text{ °C}$	[1]	-	-2.04	-	mV/°C
LLS intercept at 0 °C	$T_{amb} = -40\text{ °C to }+105\text{ °C}$	[1]	-	584.0	-	mV
Value at 30 °C		[2]	515.9	-	531.5	mV

[1] Measured over typical samples.

[2] Measured for samples over process corners.

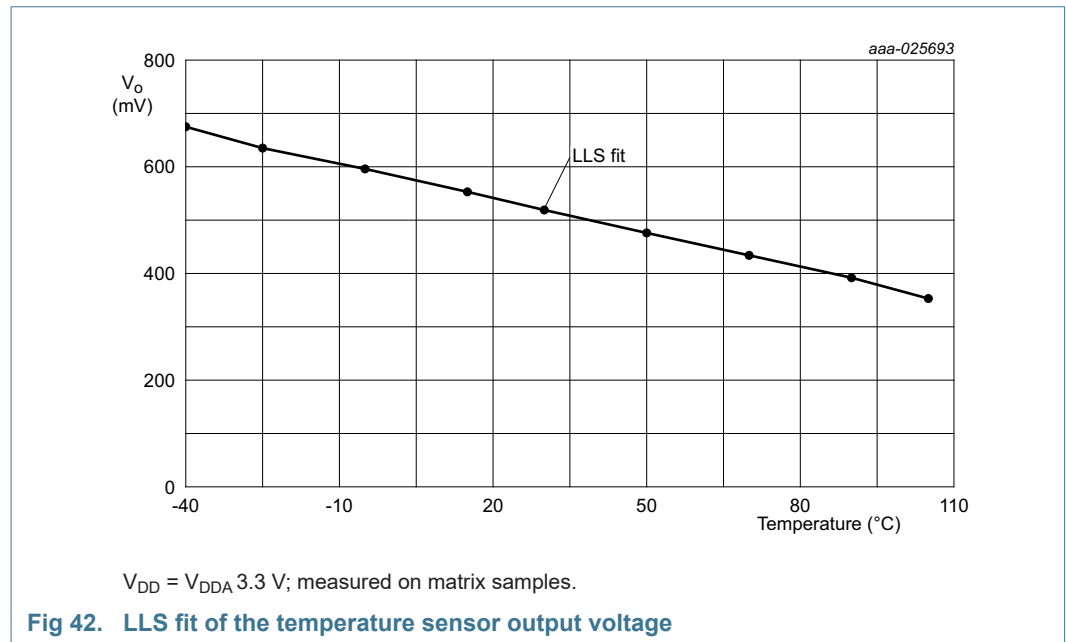

13. Application information

13.1 Start-up behavior

Figure 43 shows the start-up timing after reset. The FRO 12 MHz oscillator provides the default clock at Reset and provides a clean system clock shortly after the supply pins reach operating voltage.

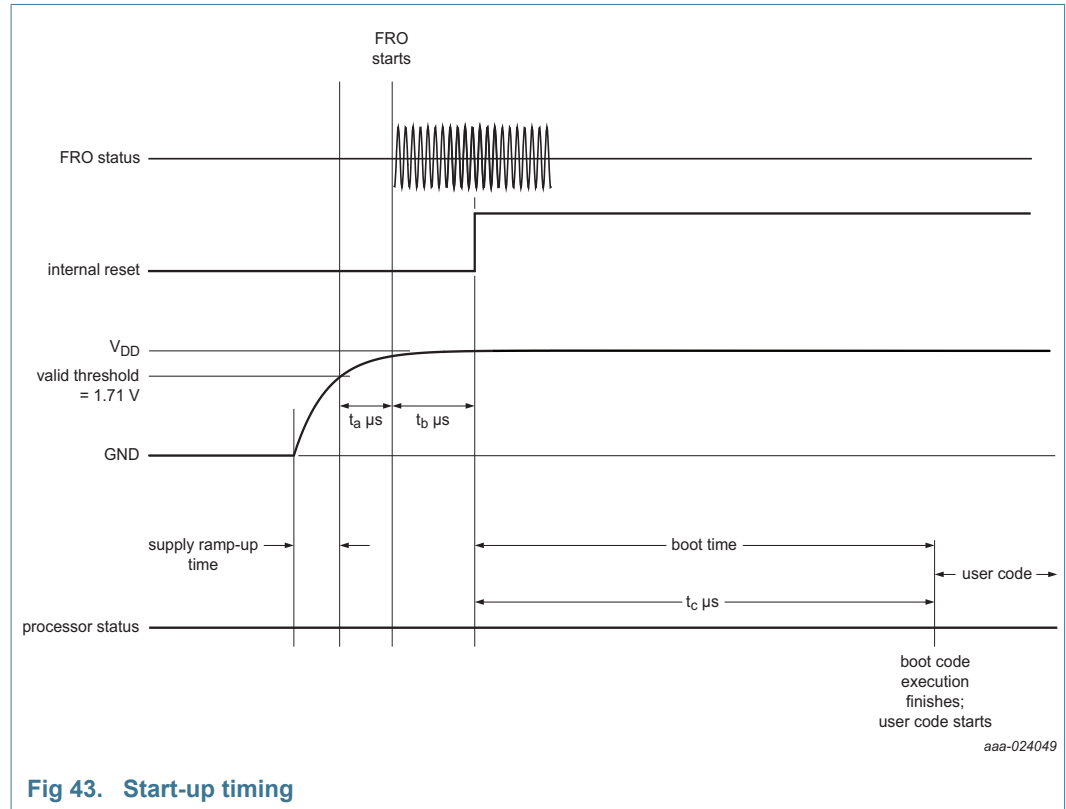

Fig 43. Start-up timing

Table 58. Typical start-up timing parameters

Parameter	Description	Value
t_a	FRO start time	$\leq 20 \mu\text{s}$
t_b	Internal reset de-asserted	151 μs
t_c	Legacy image	262 μs
	Single image without CRC	245 μs
	Dual image without CRC	289 μs

13.2 Standard I/O pin configuration

Figure 44 shows the possible pin modes for standard I/O pins:

- Digital output driver: enabled/disabled.
- Digital input: Pull-up enabled/disabled.
- Digital input: Pull-down enabled/disabled.
- Digital input: Repeater mode enabled/disabled.
- Z mode; High impedance (no cross-bar currents for floating inputs).

The default configuration for standard I/O pins is Z mode. The weak MOS devices provide a drive capability equivalent to pull-up and pull-down resistors.

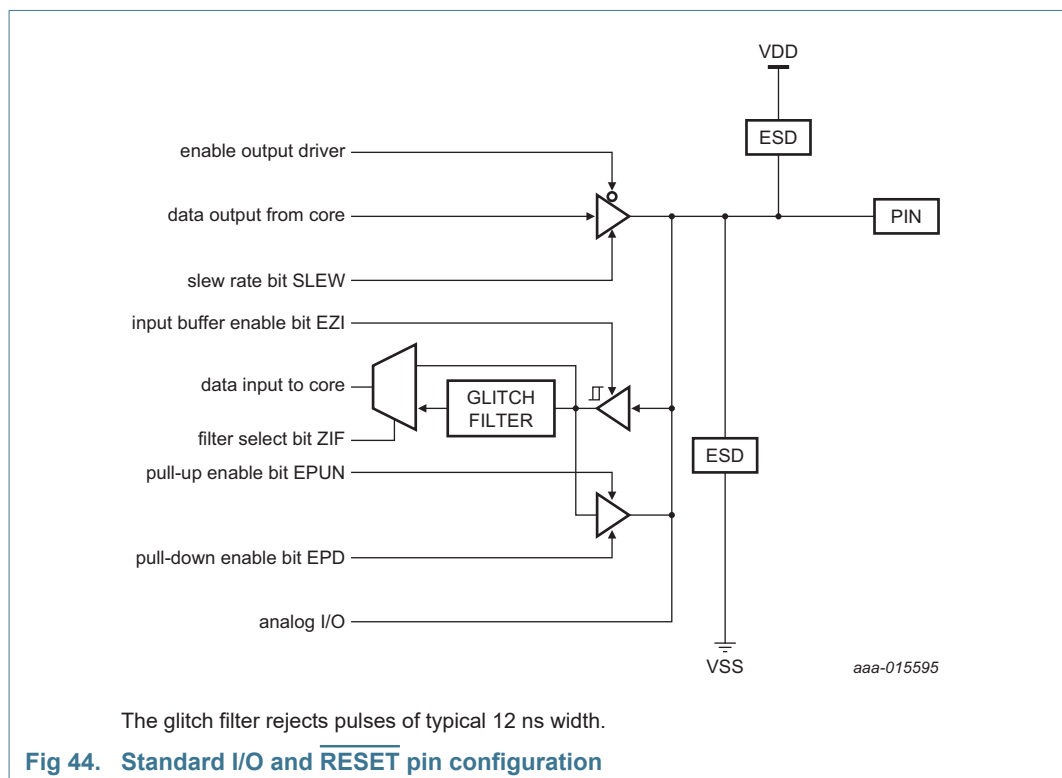

13.3 Connecting power, clocks, and debug functions

[Figure 45](#) shows the basic board connections used to power the LPC546xx. devices, connect the external crystal and the 32 kHz oscillator for the RTC, and provide debug capabilities via the serial wire port.

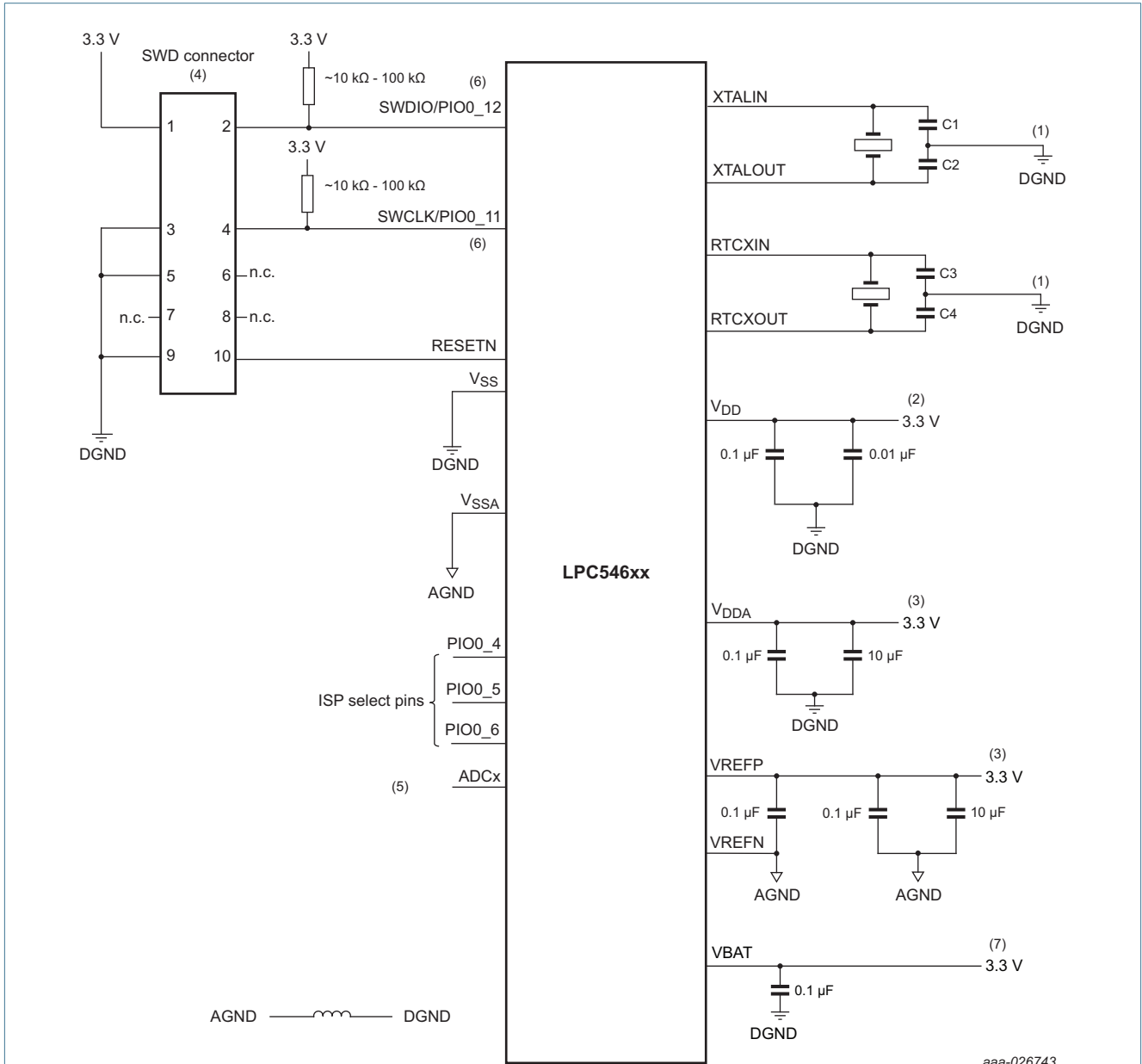

aaa-026743

- (1) See [Section 13.6 “XTAL oscillator”](#) for the values of C1, C2, C3, and C4.
- (2) Position the decoupling capacitors of 0.1 μF and 0.01 μF as close as possible to the V_{DD} pin. Add one set of decoupling capacitors to each V_{DD} pin.
- (3) Position the decoupling capacitors of 0.1 μF as close as possible to the VREFN and V_{DDA} pins. The 10 μF bypass capacitor filters the power line. Tie V_{DDA} and VREFP to V_{DD} if the ADC is not used. Tie VREFN to V_{SS} if ADC is not used.
- (4) Uses the ARM 10-pin interface for SWD.
- (5) When measuring signals of low frequency, use a low-pass filter to remove noise and to improve ADC performance. Also see [Ref. 3](#).
- (6) External pull-up resistors on SWDIO and SWCLK pins are optional because these pins have an internal pull-up enabled by default.
- (7) Position the decoupling capacitor of 0.1 μF as close as possible to the V_{BAT} pin. Tie V_{BAT} to V_{DD} if not used.

Fig 45. Power, clock, and debug connections

13.4 I/O power consumption

I/O pins are contributing to the overall dynamic and static power consumption of the part. If pins are configured as digital inputs, a static current can flow depending on the voltage level at the pin and the setting of the internal pull-up and pull-down resistors. This current can be calculated using the parameters R_{pu} and R_{pd} given in [Table 21](#) for a given input voltage V_I . For pins set to output, the current drive strength is given by parameters I_{OH} and I_{OL} in [Table 21](#), but for calculating the total static current, you also need to consider any external loads connected to the pin.

I/O pins also contribute to the dynamic power consumption when the pins are switching because the V_{DD} supply provides the current to charge and discharge all internal and external capacitive loads connected to the pin in addition to powering the I/O circuitry.

The contribution from the I/O switching current I_{sw} can be calculated as follows for any given switching frequency f_{sw} if the external capacitive load (C_{ext}) is known (see [Table 21](#) for the internal I/O capacitance):

$$I_{sw} = V_{DD} \times f_{sw} \times (C_{io} + C_{ext})$$

13.5 RTC oscillator

In the RTC oscillator circuit, only the crystal (XTAL) and the capacitances C_{X1} and C_{X2} need to be connected externally on RTCXIN and RTCXOUT. See [Figure 46](#).

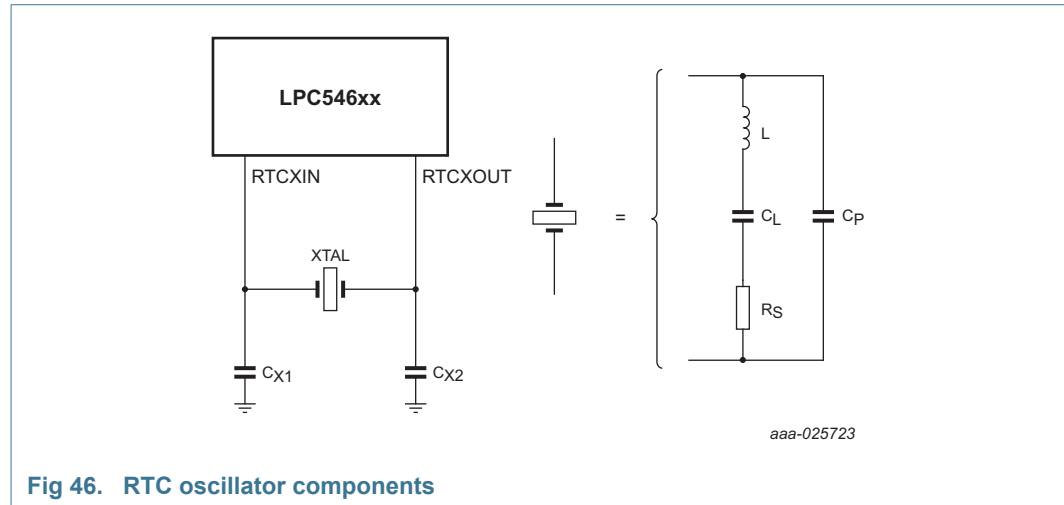

Fig 46. RTC oscillator components

For best results, it is very critical to select a matching crystal for the on-chip oscillator. Load capacitance (C_L), series resistance (R_S), and drive level (DL) are important parameters to consider while choosing the crystal. After selecting the proper crystal, the external load capacitor C_{X1} and C_{X2} values can also be generally determined by the following expression:

$$C_{X1} = C_{X2} = 2C_L - (C_{Pad} + C_{Parasitic})$$

Where:

C_L - Crystal load capacitance

C_{Pad} - Pad capacitance of the RTCXIN and RTCXOUT pins (~3 pF).

$C_{Parasitic}$ - Parasitic or stray capacitance of external circuit.

Although $C_{Parasitic}$ can be ignored in general, the actual board layout and placement of external components influences the optimal values of external load capacitors. Therefore, it is recommended to fine tune the values of external load capacitors on actual hardware board to get the accurate clock frequency. For fine tuning, output the RTC Clock to the CLOCKOUT pin and optimize the values of external load capacitors for minimum frequency deviation.

13.5.1 RTC Printed Circuit Board (PCB) design guidelines

- Connect the crystal and external load capacitors on the PCB as close as possible to the oscillator input and output pins of the chip.
- The length of traces in the oscillation circuit should be as short as possible and must not cross other signal lines.
- Ensure that the load capacitors CX1, CX2, and CX3, in case of third overtone crystal usage, have a common ground plane.
- Loops must be made as small as possible to minimize the noise coupled in through the PCB and to keep the parasitics as small as possible.
- Lay out the ground (GND) pattern under crystal unit.
- Do not lay out other signal lines under crystal unit for multi-layered PCB.

13.6 XTAL oscillator

In the XTAL oscillator circuit, only the crystal (XTAL) and the capacitances C_{X1} and C_{X2} need to be connected externally on XTALIN and XTALOUT. See [Figure 47](#).

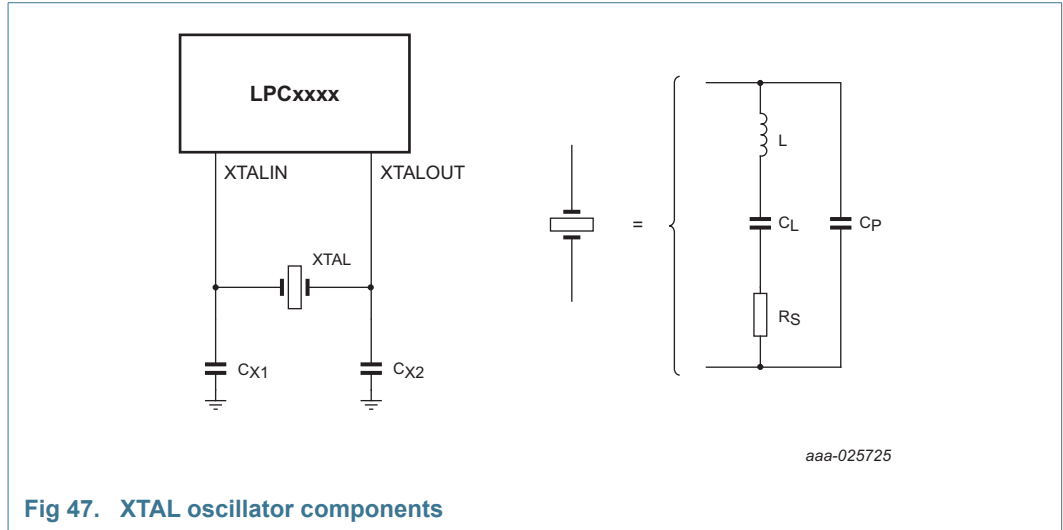

Fig 47. XTAL oscillator components

For best results, it is very critical to select a matching crystal for the on-chip oscillator. Load capacitance (C_L), series resistance (R_S), and drive level (DL) are important parameters to consider while choosing the crystal. After selecting the proper crystal, the external load capacitor C_{X1} and C_{X2} values can also be generally determined by the following expression:

$$C_{X1} = C_{X2} = 2C_L - (C_{Pad} + C_{Parasitic})$$

Where:

C_L - Crystal load capacitance

C_{Pad} - Pad capacitance of the XTALIN and XTALOUT pins (~3 pF).

$C_{Parasitic}$ - Parasitic or stray capacitance of external circuit.

Although $C_{Parasitic}$ can be ignored in general, the actual board layout and placement of external components influences the optimal values of external load capacitors. Therefore, it is recommended to fine tune the values of external load capacitors on actual hardware board to get the accurate clock frequency. For fine tuning, measure the clock on the XTALOUT pin and optimize the values of external load capacitors for minimum frequency deviation.

13.6.1 XTAL Printed Circuit Board (PCB) design guidelines

- Connect the crystal and external load capacitors on the PCB as close as possible to the oscillator input and output pins of the chip.
- The length of traces in the oscillation circuit should be as short as possible and must not cross other signal lines.
- Ensure that the load capacitors CX1, CX2, and CX3, in case of third overtone crystal usage, have a common ground plane.
- Loops must be made as small as possible to minimize the noise coupled in through the PCB and to keep the parasitics as small as possible.
- Lay out the ground (GND) pattern under crystal unit.
- Do not lay out other signal lines under crystal unit for multi-layered PCB.

13.7 Suggested USB0 Full-speed interface solutions

The USB device can be connected to the USB as self-powered device (see [Figure 48](#)) or bus-powered device (see [Figure 49](#)).

On the LPC546xx, the USB_VBUS pin is 5 V tolerant only when V_{DD} is applied and at operating voltage level. Therefore, if the USB_VBUS function is connected to the USB connector and the device is self-powered, the USB_VBUS pin must be protected for situations when $V_{DD} = 0$ V.

If V_{DD} is always at operating level while $VBUS = 5$ V, the USB_VBUS pin can be connected directly to the VBUS pin on the USB connector.

For systems where V_{DD} can be 0 V and VBUS is directly applied to the VBUS pin, precautions must be taken to reduce the voltage to below 3.6 V, which is the maximum allowable voltage on the USB_VBUS pin in this case.

One method is to use a voltage divider to connect the USB_VBUS pin to the VBUS on the USB connector. The voltage divider ratio should be such that the USB_VBUS pin is greater than $0.7 V_{DD}$ to indicate a logic HIGH while below the 3.6 V allowable maximum voltage.

For the following operating conditions

$$VBUS_{max} = 5.25 \text{ V}$$

$$V_{DD} = 3.6 \text{ V,}$$

the voltage divider should provide a reduction of $3.6 \text{ V}/5.25 \text{ V}$ or ~ 0.686 V.

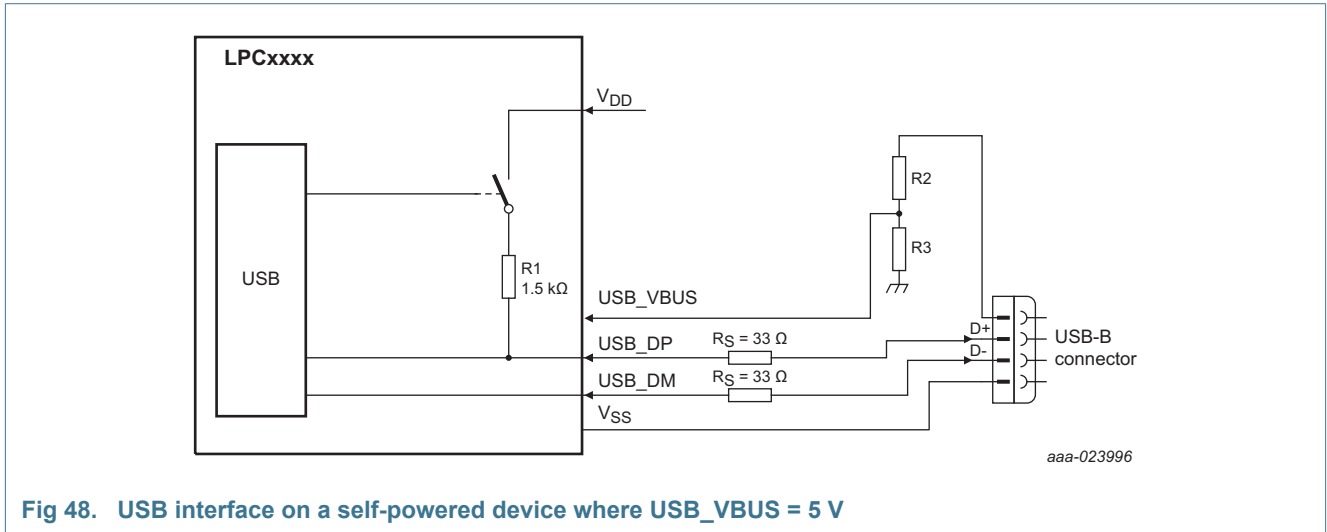
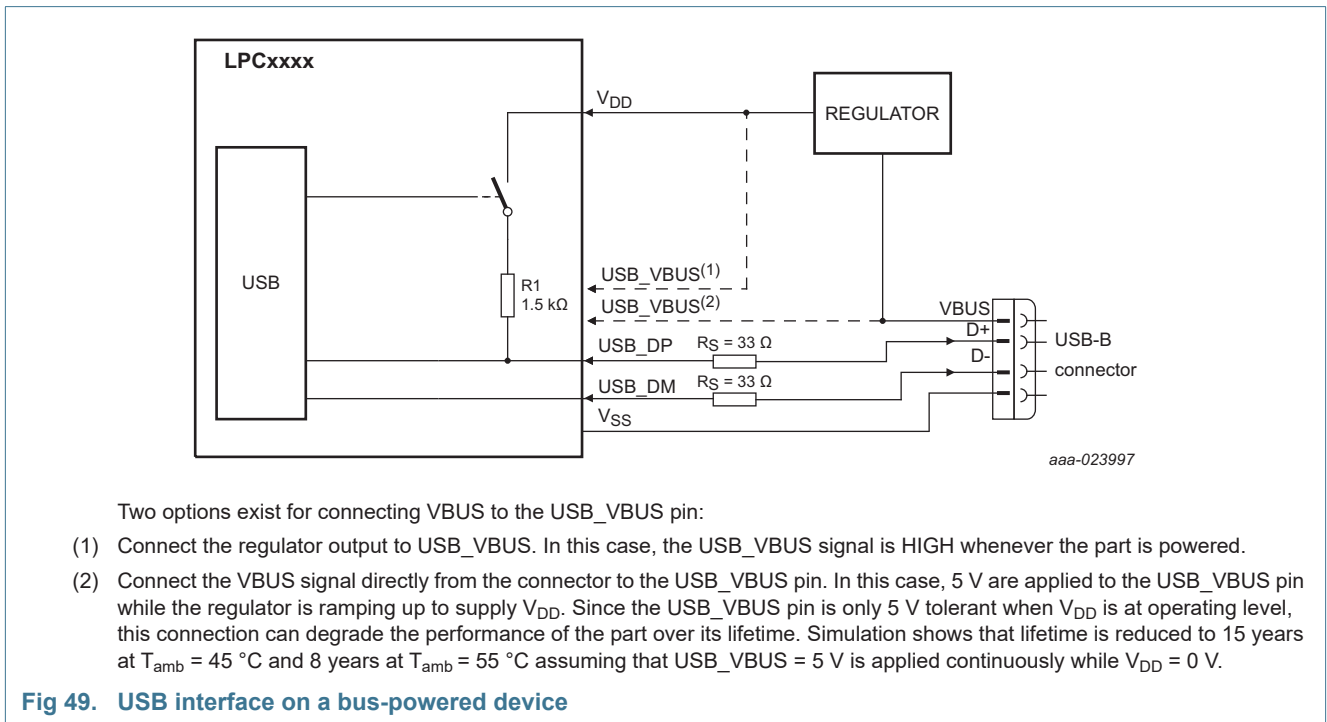

Fig 48. USB interface on a self-powered device where USB_VBUS = 5 V

The internal pull-up (1.5 kΩ) can be enabled by setting the DCON bit in the DEVCMDSTAT register to prevent the USB from timing out when there is a significant delay between power-up and handling USB traffic. External circuitry is not required.



Two options exist for connecting VBUS to the USB_VBUS pin:

- (1) Connect the regulator output to USB_VBUS. In this case, the USB_VBUS signal is HIGH whenever the part is powered.
- (2) Connect the VBUS signal directly from the connector to the USB_VBUS pin. In this case, 5 V are applied to the USB_VBUS pin while the regulator is ramping up to supply VDD. Since the USB_VBUS pin is only 5 V tolerant when VDD is at operating level, this connection can degrade the performance of the part over its lifetime. Simulation shows that lifetime is reduced to 15 years at T_{amb} = 45 °C and 8 years at T_{amb} = 55 °C assuming that USB_VBUS = 5 V is applied continuously while VDD = 0 V.

Fig 49. USB interface on a bus-powered device

13.8 USB1 High-speed VBUS threshold levels

The USB1 has the following characteristics for VBUS (see [Table 59](#)). The USB1_VBUS can tolerate an input voltage of 5.5 V.

Table 59. USB1 High-speed VBUS threshold levels

Function	Min	Typ	Max	Unit
Votg_sess_valid	0.8	-	4.0	V
VBUS_valid (high-power)	4.75	-	5.5	V
VBUS_valid (low-power)	4.192	-	5.5	V
Vadp_probe	0.6	–	0.8	V
Vadp_sense	0.20	–	0.55	V

14. Package outline

LQFP208; plastic low profile quad flat package; 208 leads; body 28 x 28 x 1.4 mm

SOT459-1

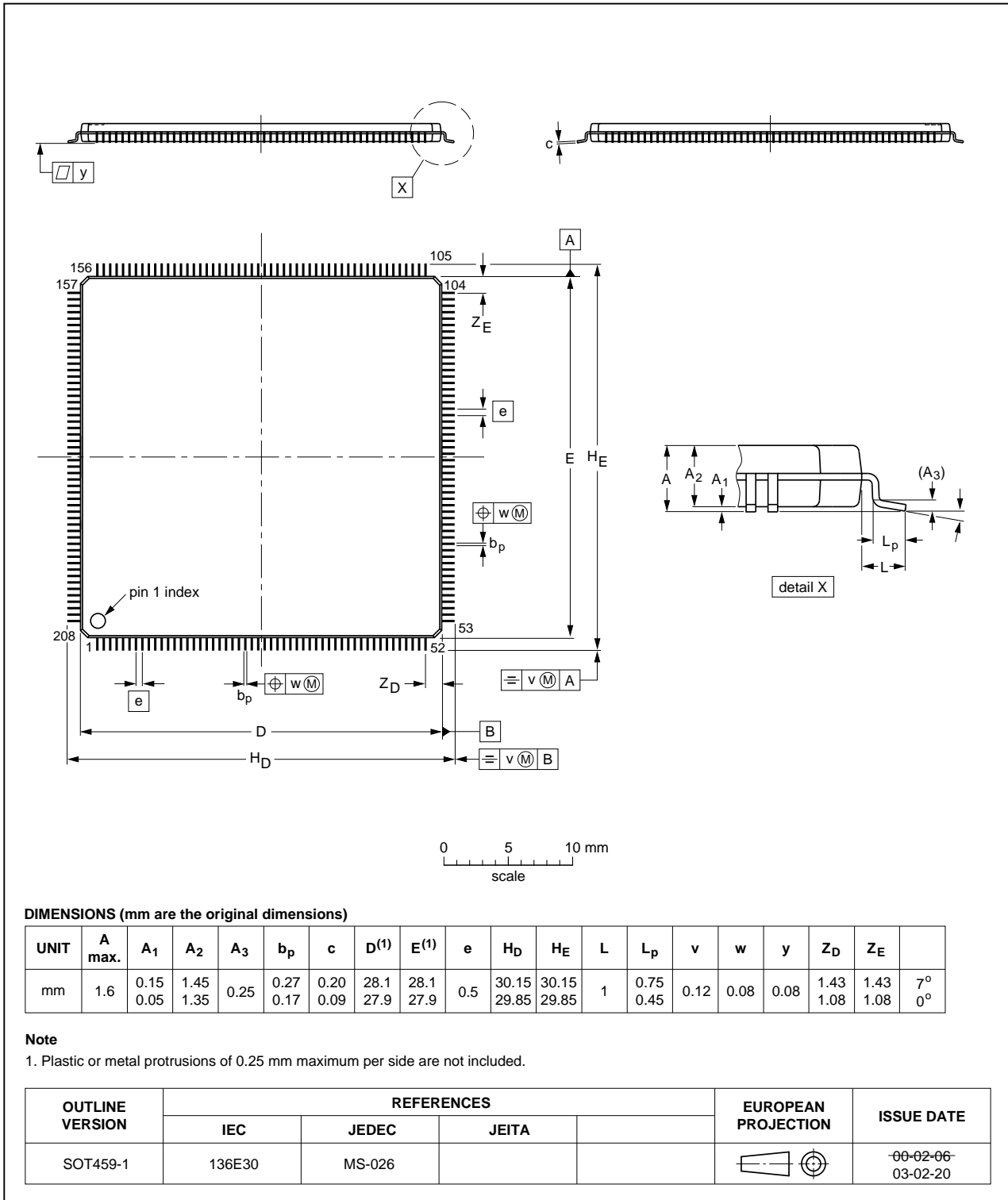

Fig 50. LQFP208 package

LQFP100: plastic low profile quad flat package; 100 leads; body 14 x 14 x 1.4 mm

SOT407-1

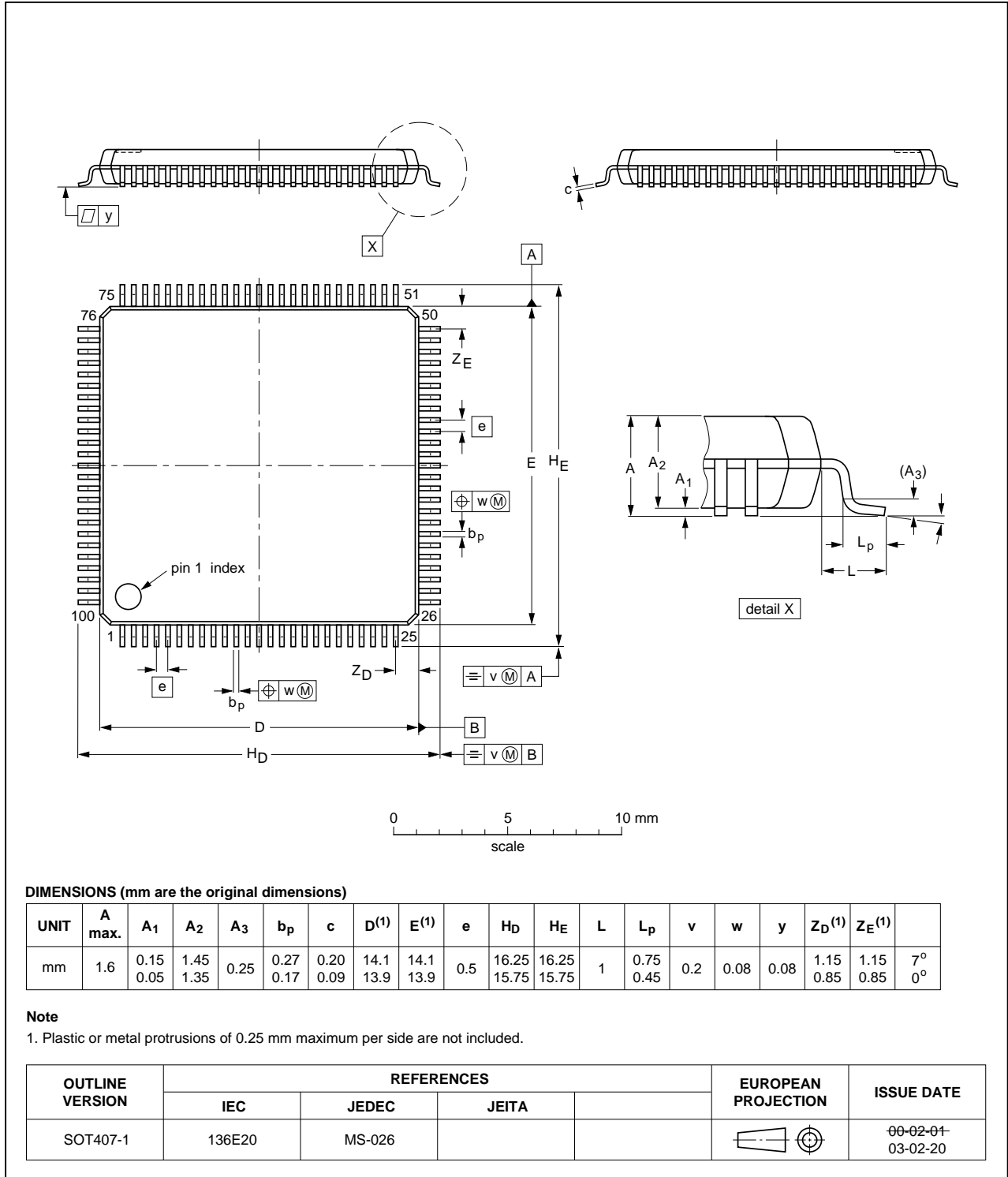

Fig 51. LQFP100 package

TFBGA180: thin fine-pitch ball grid array package; 180 balls

SOT570-3

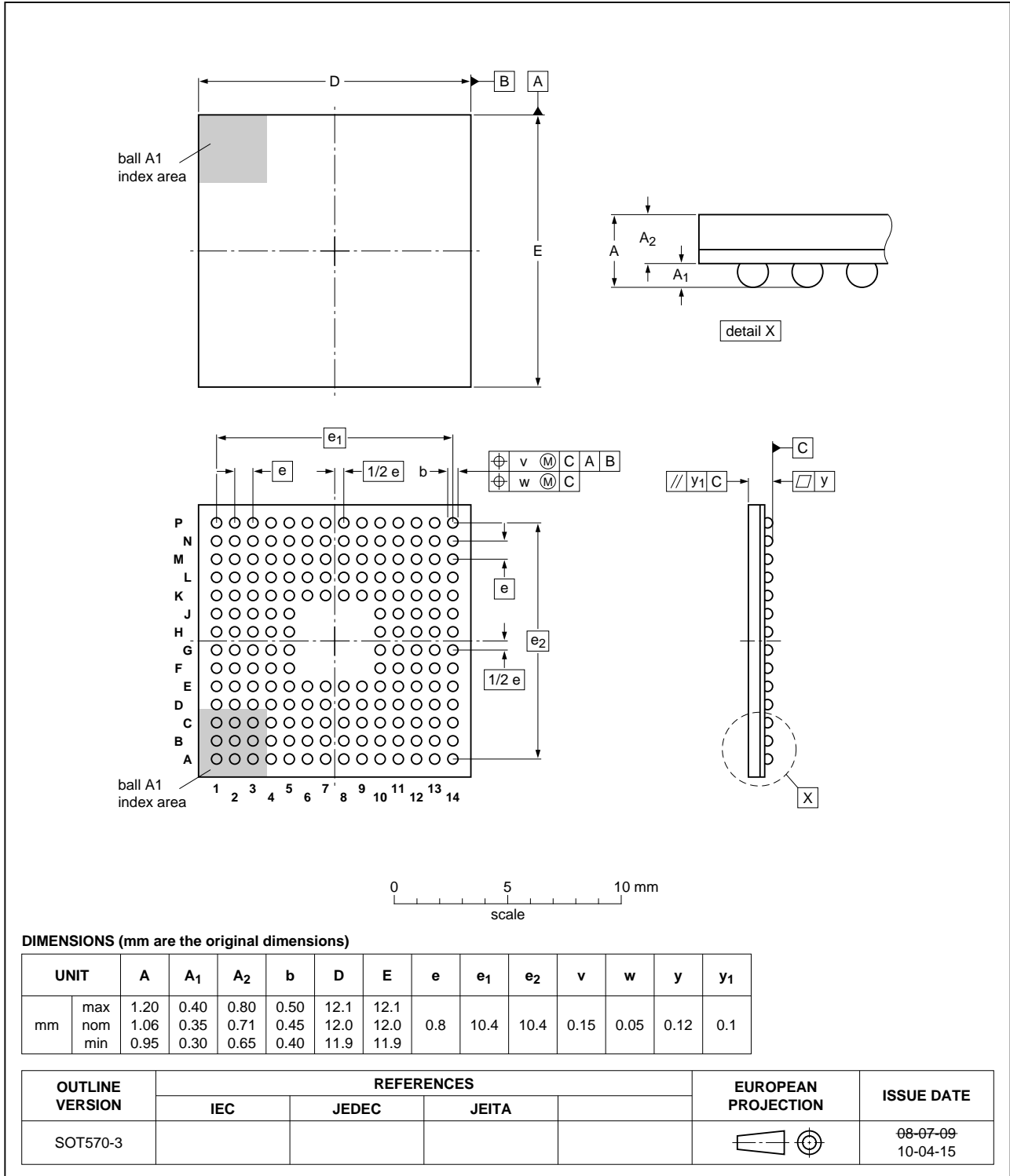

Fig 52. TFBGA180 package

TFBGA100: plastic thin fine-pitch ball grid array package; 100 balls; body 9 x 9 x 0.7 mm

SOT926-1

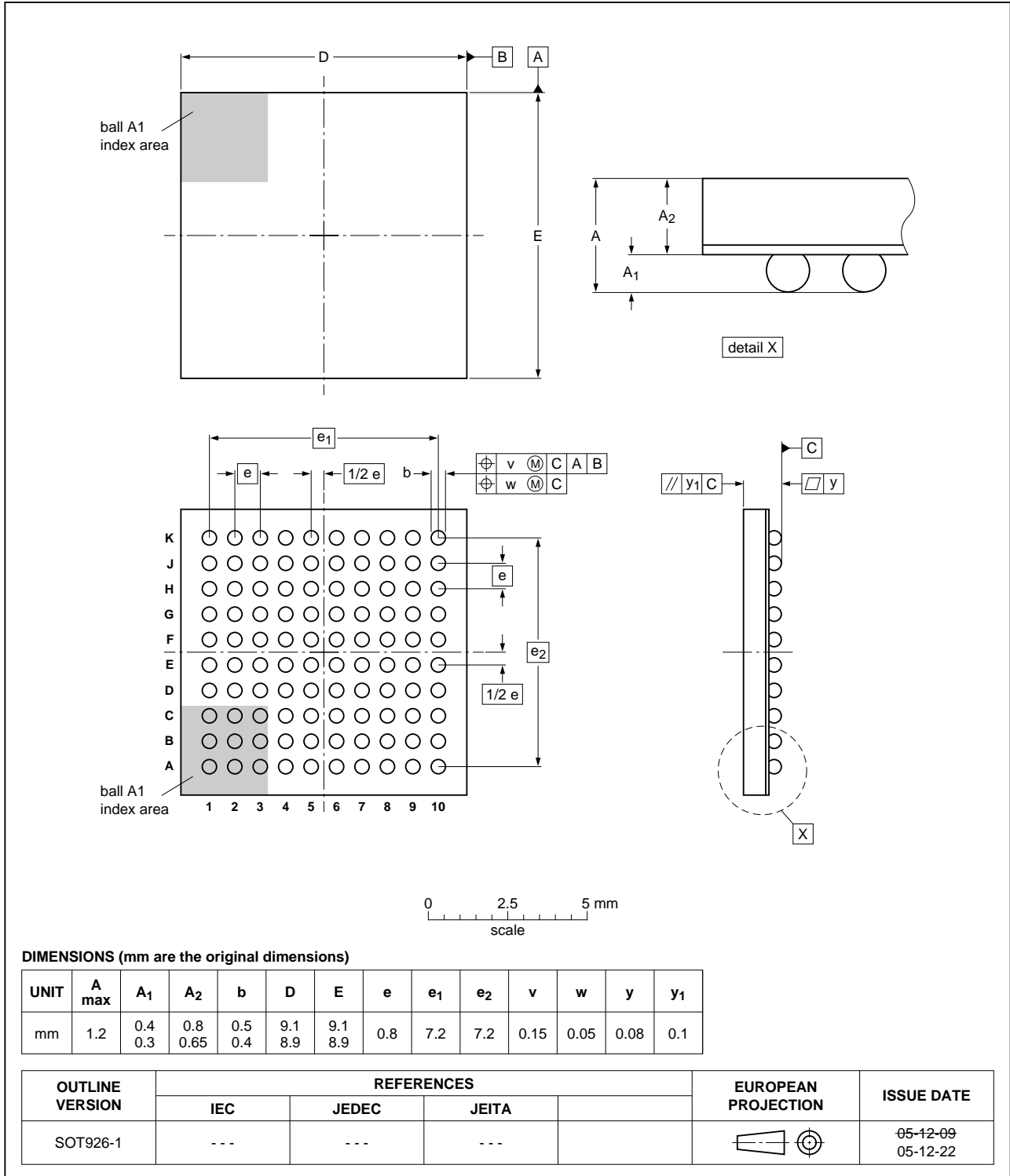

Fig 53. TFBGA100 package

15. Soldering

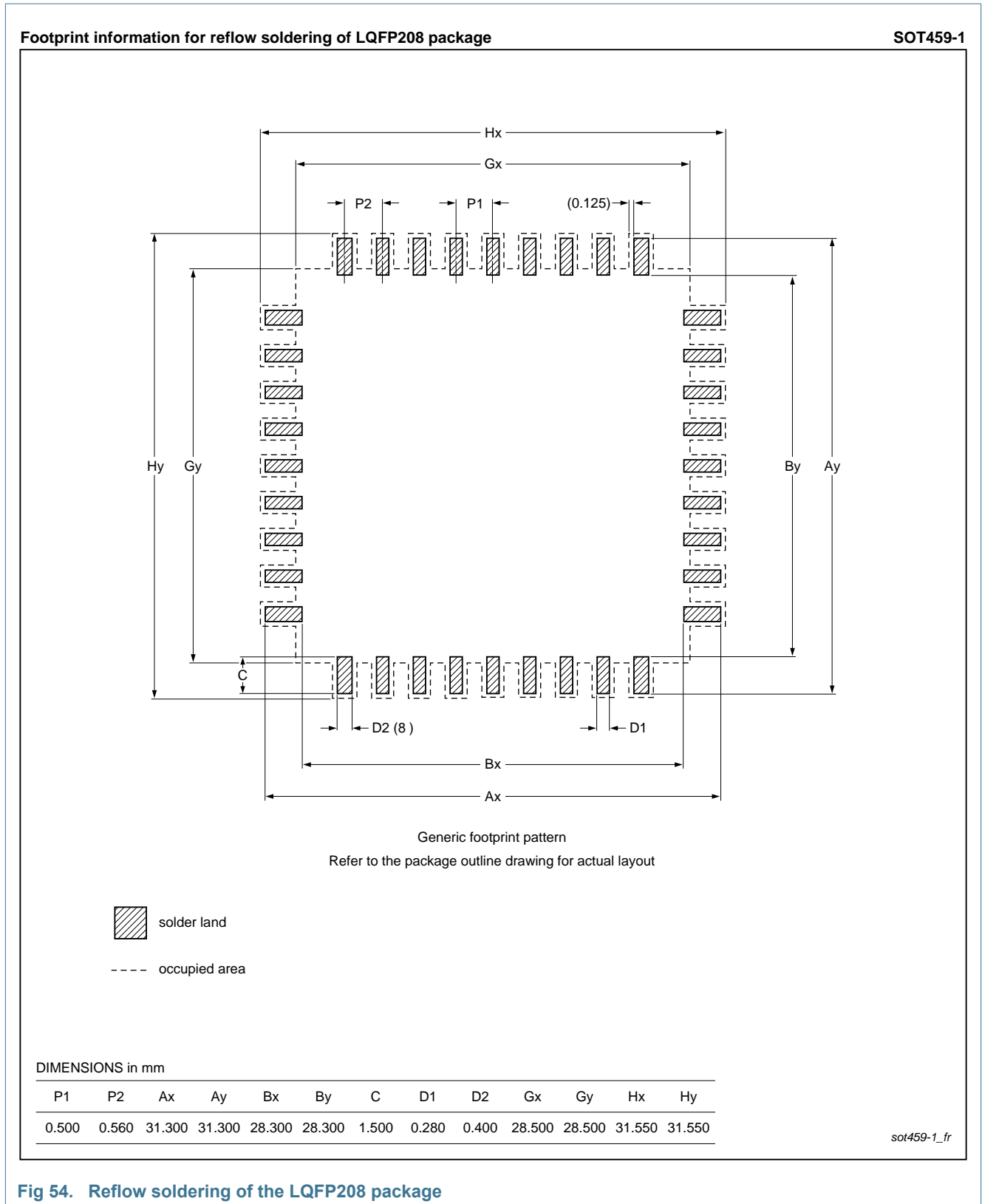

Fig 54. Reflow soldering of the LQFP208 package

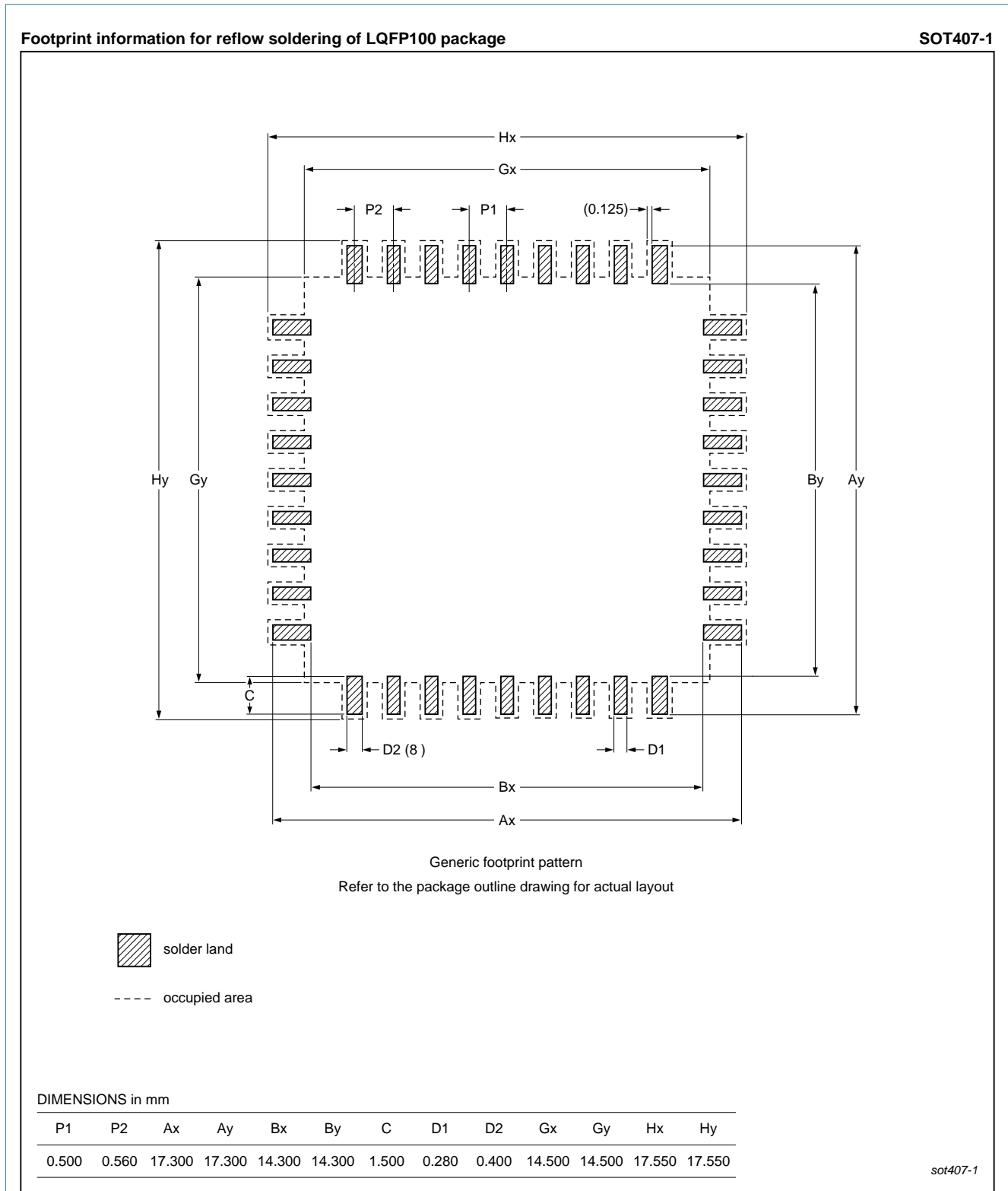
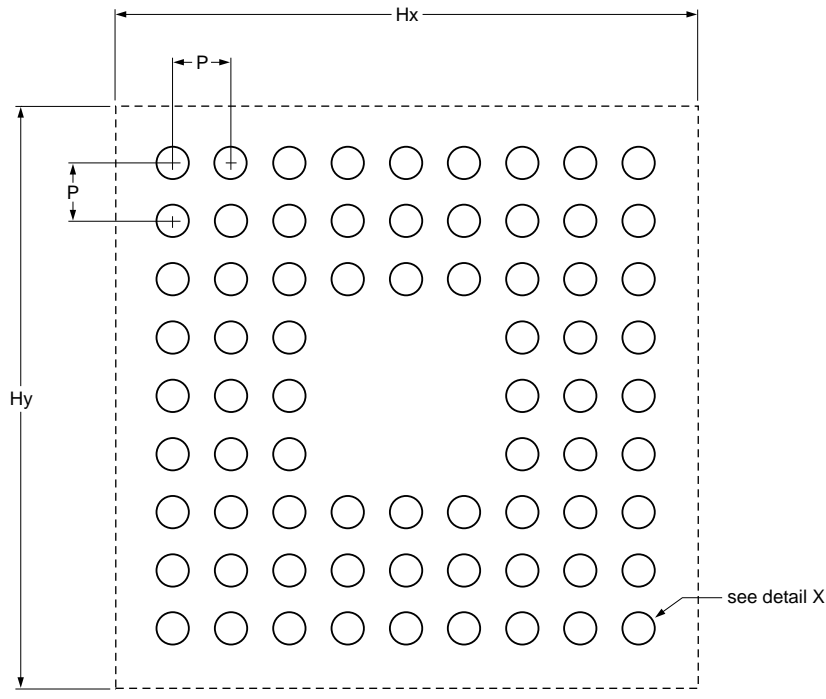

Fig 55. Reflow soldering of the LQFP100 package

Footprint information for reflow soldering of TFBGA180 package

SOT570-3



Generic footprint pattern
Refer to the package outline drawing for actual layout

- solder land
- solder paste deposit
- solder land plus solder paste
- occupied area
- _____ solder resist

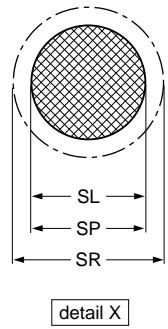

DIMENSIONS in mm

P	SL	SP	SR	Hx	Hy
0.80	0.400	0.400	0.550	12.575	12.575

sot570-3_fr



Fig 56. Reflow soldering of the TFBGA180 package

Footprint information for reflow soldering of TFBGA100 package

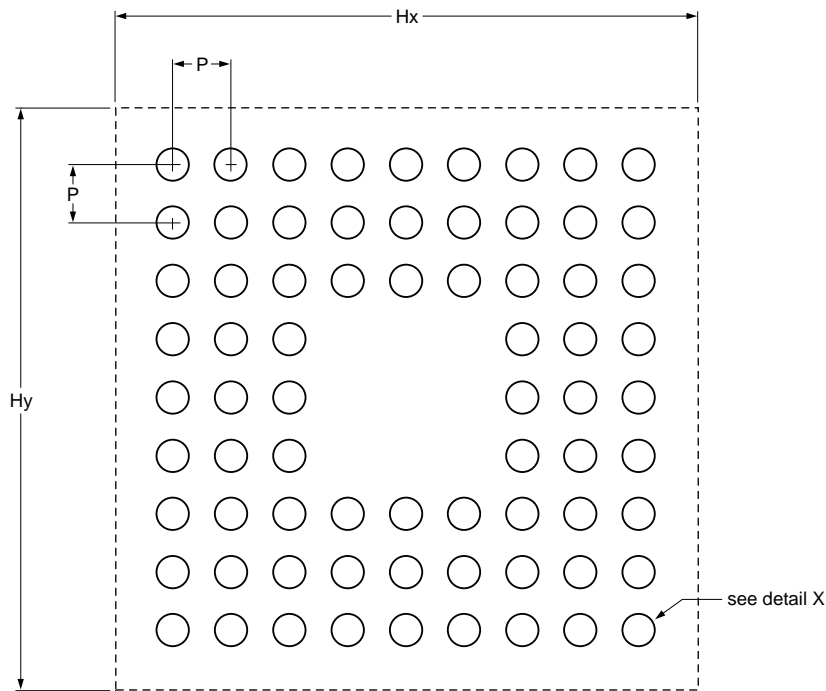
SOT926-1



Generic footprint pattern
Refer to the package outline drawing for actual layout

-  solder land
-  solder paste deposit
-  solder land plus solder paste
- occupied area
- solder resist

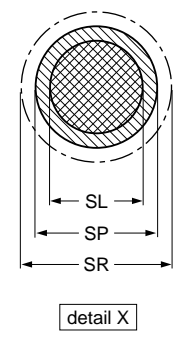

DIMENSIONS in mm

P	SL	SP	SR	Hx	Hy
0.80	0.330	0.400	0.480	9.400	9.400

sot926-1_fr

Fig 57. Reflow soldering of the TFBGA100 package

16. Abbreviations

Table 60. Abbreviations

Acronym	Description
AHB	Advanced High-performance Bus
APB	Advanced Peripheral Bus
API	Application Programming Interface
DMA	Direct Memory Access
FRO oscillator	Internal Free-Running Oscillator, tuned to the factory specified frequency
GPIO	General Purpose Input/Output
FRO	Free Running Oscillator
LSB	Least Significant Bit
MCU	MicroController Unit
PDM	Pulse Density Modulation
PLL	Phase-Locked Loop
SPI	Serial Peripheral Interface
TCP/IP	Transmission Control Protocol/Internet Protocol
TTL	Transistor-Transistor Logic
USART	Universal Asynchronous Receiver/Transmitter

17. References

- [1] LPC546xx. User manual UM10912.
- [2] LPC546xx. Errata sheet.
- [3] Technical note ADC design guidelines:
http://www.nxp.com/documents/technical_note/TN00009.pdf

18. Revision history

Table 61. Revision history

Document ID	Release date	Data sheet status	Change notice	Supersedes
LPC546xx v.2.7	20200221	Product data sheet		LPC546xx v.2.6
Modifications:				<ul style="list-style-type: none"> Added Section 13.8 “USB1 High-speed VBUS threshold levels”.
LPC546xx v.2.6	20181023	Product data sheet		LPC546xx v.2.5
Modifications:				<ul style="list-style-type: none"> Updated Table 4 “Pin description”: Added text to USB1_VBUS. Updated Table 12 “General operating conditions”: Added V_{DD} for USB high-speed operation only. Changed USB operation to: For USB full-speed operation only. Added USB1 analog supply. Updated Section 7.14.2 “Deep-sleep mode”: Added text: In deep-sleep mode, the system clock to the processor is disabled as in sleep mode. All analog blocks are powered down by default but can be selected to keep running through the power API if needed as wake-up sources. The main clock and all peripheral clocks are disabled by default.
LPC546xx v.2.5	20180620	Product data sheet		LPC546xx v.2.4
Modifications:				<ul style="list-style-type: none"> Updated Figure 14 “Typical CoreMark score (iterations/s/MHz) vs. Frequency (MHz) from flash and SRAMX” Updated Table 14 “CoreMark score[1]”. Updated Table 4 “Pin description”: Description of VREFN and VSSA. Updated Table 5 “Termination of unused pins”: Added USB1_ID pin.
LPC546xx v.2.4	20180524	Product data sheet	201805030I	LPC546xx v.2.3
Modifications:				<ul style="list-style-type: none"> Added text to serial interfaces to Section 2 “Features and benefits”: USB 2.0 full-speed host/device controller with on-chip PHY and dedicated DMA controller supporting crystal-less operation in device mode using software library. See Technical note TN00032 for more details. Added table note 2 of Section 6.2.2 “Pin states in different power modes”: If VBAT > VDD, the external reset pin must be floating to prevent high VBAT leakage. Added table note 3 to Table 18 “Static characteristics: Power consumption in deep power-down mode”: If VBAT > VDD, the external reset pin must be floating to prevent high VBAT leakage. Added remark to Figure 16 “Deep-sleep mode: Typical supply current I_{DD} versus temperature for different supply voltages VDD”: At hot temperature and below 2.0 V, the supply current could increase slightly because of reduction of available RBB (reverse body bias) voltage. Updated Table 16 “Static characteristics: Power consumption in deep-sleep and deep power-down modes”: I_{DD} supply current, Deep-sleep mode; Flash is powered down for SRAMX (32 KB) powered T_{amb} = 25 °C and T_{amb} = 105 °C; Max values: 69 μA and 1150 μA. Updated table note 3: Tested in production. VDD = 1.71 V. At hot temperature and below 2.0 V, the supply current could increase slightly because of reduction of available RBB (reverse body bias) voltage. Updated Table 17 “Static characteristics: Power consumption in deep-sleep and deep power-down modes”: I_{DD} supply current, Deep-sleep mode; Flash is powered down for SRAMX (32 KB) powered T_{amb} = 25 °C; Max value: 69 μA.
LPC546xx v.2.3	20180426	Product data sheet	-	LPC546xx v.2.2
Modifications:				<ul style="list-style-type: none"> Updated Table 4 “Pin description”: VREFN and VSSA.
LPC546xx v.2.2	20180417	Product data sheet	-	LPC546xx v.2.1
Modifications:				<ul style="list-style-type: none"> Updated Table 25 “Dynamic characteristic: Typical wake-up times from low power modes”: Changed t_{wake} at typical for deep-sleep mode to 150 μs. Was 19 μs.

Table 61. Revision history ...continued

Document ID	Release date	Data sheet status	Change notice	Supersedes
LPC546xx v.2.1	20180206	Product data sheet	-	LPC546xx v.2.0
Modifications:	<ul style="list-style-type: none"> Updated Figure 3 “LQFP100 package marking”. Fixed Figure 4 “LPC546xx Block diagram” figure number identifier. Fixed Figure 9 “LPC546xx Memory mapping” figure number identifier. 			
LPC546xx v.2.0	20180126	Product data sheet	-	LPC546xx v.1.9
Modifications:	<ul style="list-style-type: none"> Updated a feature in Section 7.17.8.2 “SPI serial I/O controller”: Maximum data rate of 48 Mbit/s in master mode and 14 Mbit/s in slave mode for SPI functions. Was 71 Mbit/s in master mode. Updated Section 11.15 “SPI interfaces”: the maximum supported bit rate for SPI master mode is 48 Mbit/s. Was 71 Mbit/s. Updated Table 4 “Pin description”: Changed restate state of PIO3_23 and PIO0_24 to Z. Added footnote True open-drain pin. I2C-bus pins compliant with the I2C-bus specification for I2C standard mode, I2C Fast-mode, and I2C Fast-mode Plus. The pin requires an external pull-up to provide output functionality. When power is switched off, this pin is floating and does not disturb the I2C lines. Open-drain configuration applies to all functions on this pin to PIO3_23 and PIO0_24. 			
LPC546xx v.1.9	20171109	Product data sheet	-	LPC546xx v.1.8
Modifications:	<ul style="list-style-type: none"> Updated Table 1 “Ordering information” and Table 2 “Ordering options”. Added the part numbers: LPC54605J256BD100, LPC54605J512BD100, LPC54605J256ET100, LPC54605J512ET100. 			
LPC546xx v.1.8	20170614	Product data sheet	-	LPC546xx v.1.7
Modifications:	<ul style="list-style-type: none"> Updated Section 13.7 “Suggested USB interface solutions”. Removed the remark. Added LPC5462x device to the data sheet. Updated Timer and digital peripherals of Section 2 “Features and benefits”. Updated Section 7.19.2 “SCTimer/PWM”, Section 7.19.2.1 “Features” and Section 7.18.3 “External memory controller”. Updated Figure 13 “Typical CoreMark score (iterations/s) vs. Frequency (MHz) from flash and SRAMX” and Figure 14 “CoreMark power consumption: typical mA/MHz vs. frequency (MHz) from flash and SRAMX”. Updated Table 42 “Dynamic characteristics: I2S-bus interface pins [1][4]”, Table 43 “SPI dynamic characteristics[1]”, Table 44 “Dynamic characteristics: SPIFI[1]”, Table 45 “Dynamic characteristics[1]”, Table 46 “Dynamic characteristics[1]”, Table 47 “USART dynamic characteristics[1]”, Table 50 “Dynamic characteristics: Ethernet”, Table 51 “Dynamic characteristics: SD/MMC and SDIO”, and Table 52 “Dynamic characteristics: LCD”: replaced the condition, CCLK > 100 MHz with 100 MHz < CCLK ≤ 180 MHz Updated Table 12 “General operating conditions”. Added the condition, For OTP programming only to f_{clk}. Added Remark to Section 7.24 “Code security (enhanced Code Read Protection - eCRP)”. Updated Table 19 “Typical peripheral power consumption[1][2]”: added SYSOSC value. Updated Table 14 “CoreMark score[1]”. Updated Table 15 “Static characteristics: Power consumption in active and sleep mode”: I_{DD} supply current in Active mode: CoreMark code executed from flash. Updated Figure 13 “Typical CoreMark score (iterations/s) vs. Frequency (MHz) from flash and SRAMX” and Figure 14 “CoreMark power consumption: typical mA/MHz vs. frequency (MHz) from flash and SRAMX”. 			

Table 61. Revision history ...continued

Document ID	Release date	Data sheet status	Change notice	Supersedes
LPC546xx v.1.7	20170428	Product data sheet	-	LPC546xx v.1.6
Modifications:	<ul style="list-style-type: none"> Updated Table 42 “Dynamic characteristics: I2S-bus interface pins [1][4]”. Updated Table 11 “Thermal resistance”. 			
LPC546xx v.1.6		Product data sheet	-	LPC546xx v.1.5
Modifications:	<ul style="list-style-type: none"> Added TFBGA100 and LQFP100 packages. 			
LPC546xx v.1.5	20170331	Product data sheet	-	LPC546xx v.1.4
Modifications:	<ul style="list-style-type: none"> Updated Table 51 “Dynamic characteristics: SD/MMC and SDIO”. The max clock frequency is 50 MHz. Updated Section 7.18.2 “SD/MMC card interface”: Supports up to a maximum of 50 MHz of interface frequency. Updated Table 41 “Dynamic characteristic: I2C-bus pins[1]” Updated Figure 28 “I2S-bus timing (master)” and Figure 29 “I2S-bus timing (slave)”. Updated Table 2 “Ordering options”. Parts LPC54618J512ET180 and LPC54618J512BD208 have Classic CAN. Added Section 11.4 “Wake-up process”. 			
LPC546xx v.1.4	20170307	Product data sheet	-	LPC5460x v.1.3
Modifications:	<ul style="list-style-type: none"> Changed data sheet title to LPC546xx. Updated Table 16 “Static characteristics: Power consumption in deep-sleep and deep power-down modes” and Table 17 “Static characteristics: Power consumption in deep-sleep and deep power-down modes”. 			
LPC5460x v.1.3	20170224	Product data sheet	-	LPC5460x v.1.2
Modifications:	<ul style="list-style-type: none"> Removed S parts. Data sheet title renamed to LPC5460x. Removed AES-256 engine and SHA references throughout the document. Security peripherals renamed to Security features. Updated Section 4 “Marking”. Updated Section 5 “Block diagram”. Updated Figure 6 “LPC546xx Memory mapping”. Updated Table 20 “Typical AHB/APB peripheral power consumption [3][4][5]”. 			
LPC5460x v.1.2	20170206	Product data sheet	-	LPC5460x v.1.1
Modifications:	<ul style="list-style-type: none"> Updated address range details and description of the address range: 0x8000 0000 to 0xDFFF FFFF: See Table 7 “Memory usage and details”: Static memory chip select: was 0x9000 0000 - 0x93 FFFF, now, 0x9000 0000 – 0x93FF FFFF. Updated Figure 8 “LPC5460x clock generation”. Updated Power control in Section 2 “Features and benefits”: Ultra-low power Micro-tick Timer, running from the Watchdog oscillator that can be used to wake up the device from low power modes. Updated Table 4 “Pin description”: PIO0_26, USB0_IDVALUE, Type is Input (I). Updated Section 7.18.1.1 “Features”. Updated Table 31 “Dynamic characteristics of the PLL0[1]”: Input frequency, F_{in}, Max value is 25 MHz. 			
LPC5460x v.1.1	20170124	Product data sheet	-	LPC5460x v.1

Table 61. Revision history ...continued

Document ID	Release date	Data sheet status	Change notice	Supersedes
Modifications:				
		<ul style="list-style-type: none"> • Regrouped Table 2 "Ordering options". • Added text to Section 7.15.3.1 "Features": Software support for AVB feature is available from NXP Professional Services. See nxp.com for more details. • Removed Table note 2: fclk = cclk/CLKDIV +1. See LPC5460x UM10912 and updated Table note 1 "See the LPC5460x user manual, UM10912 on how to program the wait states for the different read (RPHASEx) and erase/program phases (PHASEx)." of Section 11.2 "EEPROM". • Updated Table 50 "Dynamic characteristics: SD/MMC and SDIO": changed the maximum clock frequency to 52 MHz. • Updated address range details and description of the address range: 0x8000 0000 to 0xDFFF FFFF: See Table 7 "Memory usage and details". 		
LPC5460x v.1	20161215	Product data sheet	-	-

19. Legal information

19.1 Data sheet status

Document status ^{[1][2]}	Product status ^[3]	Definition
Objective [short] data sheet	Development	This document contains data from the objective specification for product development.
Preliminary [short] data sheet	Qualification	This document contains data from the preliminary specification.
Product [short] data sheet	Production	This document contains the product specification.

[1] Please consult the most recently issued document before initiating or completing a design.

[2] The term 'short data sheet' is explained in section "Definitions".

[3] The product status of device(s) described in this document may have changed since this document was published and may differ in case of multiple devices. The latest product status information is available on the Internet at URL <http://www.nxp.com>.

19.2 Definitions

Draft — The document is a draft version only. The content is still under internal review and subject to formal approval, which may result in modifications or additions. NXP Semiconductors does not give any representations or warranties as to the accuracy or completeness of information included herein and shall have no liability for the consequences of use of such information.

Short data sheet — A short data sheet is an extract from a full data sheet with the same product type number(s) and title. A short data sheet is intended for quick reference only and should not be relied upon to contain detailed and full information. For detailed and full information see the relevant full data sheet, which is available on request via the local NXP Semiconductors sales office. In case of any inconsistency or conflict with the short data sheet, the full data sheet shall prevail.

Product specification — The information and data provided in a Product data sheet shall define the specification of the product as agreed between NXP Semiconductors and its customer, unless NXP Semiconductors and customer have explicitly agreed otherwise in writing. In no event however, shall an agreement be valid in which the NXP Semiconductors product is deemed to offer functions and qualities beyond those described in the Product data sheet.

19.3 Disclaimers

Limited warranty and liability — Information in this document is believed to be accurate and reliable. However, NXP Semiconductors does not give any representations or warranties, expressed or implied, as to the accuracy or completeness of such information and shall have no liability for the consequences of use of such information. NXP Semiconductors takes no responsibility for the content in this document if provided by an information source outside of NXP Semiconductors.

In no event shall NXP Semiconductors be liable for any indirect, incidental, punitive, special or consequential damages (including - without limitation - lost profits, lost savings, business interruption, costs related to the removal or replacement of any products or rework charges) whether or not such damages are based on tort (including negligence), warranty, breach of contract or any other legal theory.

Notwithstanding any damages that customer might incur for any reason whatsoever, NXP Semiconductors' aggregate and cumulative liability towards customer for the products described herein shall be limited in accordance with the *Terms and conditions of commercial sale* of NXP Semiconductors.

Right to make changes — NXP Semiconductors reserves the right to make changes to information published in this document, including without limitation specifications and product descriptions, at any time and without notice. This document supersedes and replaces all information supplied prior to the publication hereof.

Suitability for use — NXP Semiconductors products are not designed, authorized or warranted to be suitable for use in life support, life-critical or safety-critical systems or equipment, nor in applications where failure or malfunction of an NXP Semiconductors product can reasonably be expected to result in personal injury, death or severe property or environmental damage. NXP Semiconductors and its suppliers accept no liability for inclusion and/or use of NXP Semiconductors products in such equipment or applications and therefore such inclusion and/or use is at the customer's own risk.

Applications — Applications that are described herein for any of these products are for illustrative purposes only. NXP Semiconductors makes no representation or warranty that such applications will be suitable for the specified use without further testing or modification.

Customers are responsible for the design and operation of their applications and products using NXP Semiconductors products, and NXP Semiconductors accepts no liability for any assistance with applications or customer product design. It is customer's sole responsibility to determine whether the NXP Semiconductors product is suitable and fit for the customer's applications and products planned, as well as for the planned application and use of customer's third party customer(s). Customers should provide appropriate design and operating safeguards to minimize the risks associated with their applications and products.

NXP Semiconductors does not accept any liability related to any default, damage, costs or problem which is based on any weakness or default in the customer's applications or products, or the application or use by customer's third party customer(s). Customer is responsible for doing all necessary testing for the customer's applications and products using NXP Semiconductors products in order to avoid a default of the applications and the products or of the application or use by customer's third party customer(s). NXP does not accept any liability in this respect.

Limiting values — Stress above one or more limiting values (as defined in the Absolute Maximum Ratings System of IEC 60134) will cause permanent damage to the device. Limiting values are stress ratings only and (proper) operation of the device at these or any other conditions above those given in the Recommended operating conditions section (if present) or the Characteristics sections of this document is not warranted. Constant or repeated exposure to limiting values will permanently and irreversibly affect the quality and reliability of the device.

Terms and conditions of commercial sale — NXP Semiconductors products are sold subject to the general terms and conditions of commercial sale, as published at <http://www.nxp.com/profile/terms>, unless otherwise agreed in a valid written individual agreement. In case an individual agreement is concluded only the terms and conditions of the respective agreement shall apply. NXP Semiconductors hereby expressly objects to applying the customer's general terms and conditions with regard to the purchase of NXP Semiconductors products by customer.

No offer to sell or license — Nothing in this document may be interpreted or construed as an offer to sell products that is open for acceptance or the grant, conveyance or implication of any license under any copyrights, patents or other industrial or intellectual property rights.

Export control — This document as well as the item(s) described herein may be subject to export control regulations. Export might require a prior authorization from competent authorities.

Non-automotive qualified products — Unless this data sheet expressly states that this specific NXP Semiconductors product is automotive qualified, the product is not suitable for automotive use. It is neither qualified nor tested in accordance with automotive testing or application requirements. NXP Semiconductors accepts no liability for inclusion and/or use of non-automotive qualified products in automotive equipment or applications.

In the event that customer uses the product for design-in and use in automotive applications to automotive specifications and standards, customer (a) shall use the product without NXP Semiconductors' warranty of the product for such automotive applications, use and specifications, and (b) whenever customer uses the product for automotive applications beyond

NXP Semiconductors' specifications such use shall be solely at customer's own risk, and (c) customer fully indemnifies NXP Semiconductors for any liability, damages or failed product claims resulting from customer design and use of the product for automotive applications beyond NXP Semiconductors' standard warranty and NXP Semiconductors' product specifications.

19.4 Trademarks

Notice: All referenced brands, product names, service names and trademarks are the property of their respective owners.

I²C-bus — logo is a trademark of NXP B.V.

20. Contact information

For more information, please visit: <http://www.nxp.com>

For sales office addresses, please send an email to: salesaddresses@nxp.com

21. Contents

1	General description	1	7.16.1	Features	68
2	Features and benefits	1	7.17	Serial peripherals	68
3	Ordering information	5	7.17.1	Full-speed USB Host/Device interface (USB0)	68
3.1	Ordering options	6	7.17.1.1	USB0 device controller	68
4	Marking	7	7.17.1.2	USB0 host controller	69
5	Block diagram	9	7.17.2	High-speed USB Host/Device interface (USB1)	69
6	Pinning information	11	7.17.2.1	USB1 device controller	69
6.1	Pinning	11	7.17.2.2	USB1 host controller	69
6.2	Pin description	13	7.17.3	Ethernet AVB	70
6.2.1	Termination of unused pins	53	7.17.3.1	Features	70
6.2.2	Pin states in different power modes	54	7.17.4	SPI Flash Interface (SPIFI)	70
7	Functional description	55	7.17.4.1	Features	70
7.1	Architectural overview	55	7.17.5	CAN Flexible Data (CAN FD) interface	71
7.2	ARM Cortex-M4 processor	55	7.17.5.1	Features	71
7.3	ARM Cortex-M4 integrated Floating Point Unit (FPU)	55	7.17.6	DMIC subsystem	71
7.4	Memory Protection Unit (MPU)	55	7.17.6.1	Features	71
7.5	Nested Vectored Interrupt Controller (NVIC) for Cortex-M4	56	7.17.7	Smart card interface	71
7.5.1	Features	56	7.17.7.1	Features	71
7.5.2	Interrupt sources	56	7.17.8	Flexcomm Interface serial communication	71
7.6	System Tick timer (SysTick)	56	7.17.8.1	Features	71
7.7	On-chip static RAM	56	7.17.8.2	SPI serial I/O controller	72
7.8	On-chip flash	56	7.17.8.3	I ² C-bus interface	72
7.9	On-chip ROM	56	7.17.8.4	USART	73
7.10	EEPROM	57	7.17.8.5	I ² S-bus interface	73
7.11	Memory mapping	57	7.18	Digital peripheral	74
7.12	System control	60	7.18.1	LCD controller	74
7.12.1	Clock sources	60	7.18.1.1	Features	75
7.12.1.1	Free Running Oscillator (FRO)	60	7.18.2	SD/MMC card interface	75
7.12.1.2	Watchdog oscillator (WDOSC)	60	7.18.2.1	Features	75
7.12.1.3	Crystal oscillator	61	7.18.3	External memory controller	75
7.12.2	System PLL (PLL0)	61	7.18.3.1	Features	76
7.12.3	USB PLL (PLL1)	61	7.18.4	DMA controller	77
7.12.4	Audio PLL (PLL2)	61	7.18.4.1	Features	77
7.12.5	Clock Generation	62	7.19	Counter/timers	77
7.12.6	Brownout detection	63	7.19.1	General-purpose 32-bit timers/external event counter	77
7.12.7	Safety	63	7.19.1.1	Features	77
7.13	Code security (enhanced Code Read Protection - eCRP)	64	7.19.2	SCTimer/PWM	78
7.14	Power control	64	7.19.2.1	Features	78
7.14.1	Sleep mode	64	7.19.3	Windowed WatchDog Timer (WWDT)	79
7.14.2	Deep-sleep mode	64	7.19.3.1	Features	79
7.14.3	Deep power-down mode	65	7.19.4	Real Time Clock (RTC) timer	79
7.15	General Purpose I/O (GPIO)	67	7.19.5	Multi-Rate Timer (MRT)	79
7.15.1	Features	67	7.19.5.1	Features	79
7.16	Pin interrupt/pattern engine	67	7.19.6	Repetitive Interrupt Timer (RIT)	80
			7.19.6.1	Features	80

continued >>

7.20	12-bit Analog-to-Digital Converter (ADC)	80	12.2.1	ADC input impedance	140
7.20.1	Features	80	12.3	Temperature sensor	141
7.21	CRC engine	81	13	Application information	143
7.21.1	Features	81	13.1	Start-up behavior	143
7.22	Temperature sensor	81	13.2	Standard I/O pin configuration	144
7.23	Security features	81	13.3	Connecting power, clocks, and debug functions	145
7.23.1	Features	81	13.4	I/O power consumption	147
7.23.2	SHA-1 and SHA-2	82	13.5	RTC oscillator	148
7.23.2.1	Features	82	13.5.1	RTC Printed Circuit Board (PCB) design guidelines	149
7.24	Code security (enhanced Code Read Protection - eCRP)	82	13.6	XTAL oscillator	150
7.25	Emulation and debugging	82	13.6.1	XTAL Printed Circuit Board (PCB) design guidelines	151
8	Limiting values	83	13.7	Suggested USB0 Full-speed interface solutions	151
9	Thermal characteristics	86	13.8	USB1 High-speed VBUS threshold levels	152
10	Static characteristics	87	14	Package outline	154
10.1	General operating conditions	87	15	Soldering	158
10.2	Power-up ramp conditions	88	16	Abbreviations	162
10.3	CoreMark data	88	17	References	162
10.4	Power consumption	90	18	Revision history	163
10.5	Pin characteristics	96	19	Legal information	167
10.5.1	Electrical pin characteristics	99	19.1	Data sheet status	167
11	Dynamic characteristics	102	19.2	Definitions	167
11.1	Flash memory	102	19.3	Disclaimers	167
11.2	EEPROM	102	19.4	Trademarks	168
11.3	I/O pins	103	20	Contact information	168
11.4	Wake-up process	104	21	Contents	169
11.5	External memory interface	105			
11.6	System PLL (PLL0)	114			
11.7	USB PLL (PLL1)	115			
11.8	Audio PLL (PLL2)	115			
11.9	FRO	116			
11.10	Crystal oscillator	116			
11.11	RTC oscillator	117			
11.12	Watchdog oscillator	118			
11.13	I ² C-bus	119			
11.14	I ² S-bus interface	121			
11.15	SPI interfaces	124			
11.16	SPIFI	127			
11.17	DMIC subsystem	128			
11.18	Smart card interface	129			
11.19	USART interface	130			
11.20	SCTimer/PWM output timing	131			
11.21	USB interface characteristics	131			
11.23	Ethernet AVB	132			
11.24	SD/MMC and SDIO	134			
11.25	LCD	135			
12	Analog characteristics	136			
12.1	BOD	136			
12.2	12-bit ADC characteristics	137			

Please be aware that important notices concerning this document and the product(s) described herein, have been included in section 'Legal information'.

Компания «Океан Электроники» предлагает заключение долгосрочных отношений при поставках импортных электронных компонентов на взаимовыгодных условиях!

Наши преимущества:

- Поставка оригинальных импортных электронных компонентов напрямую с производств Америки, Европы и Азии, а так же с крупнейших складов мира;
- Широкая линейка поставок активных и пассивных импортных электронных компонентов (более 30 млн. наименований);
- Поставка сложных, дефицитных, либо снятых с производства позиций;
- Оперативные сроки поставки под заказ (от 5 рабочих дней);
- Экспресс доставка в любую точку России;
- Помощь Конструкторского Отдела и консультации квалифицированных инженеров;
- Техническая поддержка проекта, помощь в подборе аналогов, поставка прототипов;
- Поставка электронных компонентов под контролем ВП;
- Система менеджмента качества сертифицирована по Международному стандарту ISO 9001;
- При необходимости вся продукция военного и аэрокосмического назначения проходит испытания и сертификацию в лаборатории (по согласованию с заказчиком);
- Поставка специализированных компонентов военного и аэрокосмического уровня качества (Xilinx, Altera, Analog Devices, Intersil, Interpoint, Microsemi, Actel, Aeroflex, Peregrine, VPT, Syfer, Eurofarad, Texas Instruments, MS Kennedy, Miteq, Cobham, E2V, MA-COM, Hittite, Mini-Circuits, General Dynamics и др.);

Компания «Океан Электроники» является официальным дистрибьютором и эксклюзивным представителем в России одного из крупнейших производителей разъемов военного и аэрокосмического назначения «JONHON», а так же официальным дистрибьютором и эксклюзивным представителем в России производителя высокотехнологичных и надежных решений для передачи СВЧ сигналов «FORSTAR».



JONHON

«JONHON» (основан в 1970 г.)

Разъемы специального, военного и аэрокосмического назначения:

(Применяются в военной, авиационной, аэрокосмической, морской, железнодорожной, горно- и нефтедобывающей отраслях промышленности)

«FORSTAR» (основан в 1998 г.)

ВЧ соединители, коаксиальные кабели, кабельные сборки и микроволновые компоненты:

(Применяются в телекоммуникациях гражданского и специального назначения, в средствах связи, РЛС, а так же военной, авиационной и аэрокосмической отраслях промышленности).



Телефон: 8 (812) 309-75-97 (многоканальный)

Факс: 8 (812) 320-03-32

Электронная почта: ocean@oceanchips.ru

Web: <http://oceanchips.ru/>

Адрес: 198099, г. Санкт-Петербург, ул. Калинина, д. 2, корп. 4, лит. А