

IBS IP CDIO/R 24-8 IBS IP CDIO/R 24-8/SF



Data Sheet

INTERBUS

Digital I/O Module
for Use on Robots

Revision C1

05/2000

Product Description

The modules are designed as compact I/O units for use on robots. In the automotive industry in particular, they can be mounted directly on the welding transformer using Kempf terminal boxes.

Features

- IP 65 protection
- Actuators and sensors are connected using 5-pos. female connectors
- Electrical isolation of I/O and bus logic
- Power supply for the bus logic and actuators provided via the hybrid cable



Operation of **both** female connectors of **one** female connector pair (pairs: female connector 1 and 2, 3 and 4, 5 and 6 or 7 and 8):

Ensure that there is a signal either at both female connectors only at pin 2 or at both female connectors only at pin 4. The simultaneous use of pin 2 and pin 4 is not permitted, as it may lead to incorrect signals.



Use of pin 2 **and** pin 4 of **one** female connector:

Ensure that the second female connector of the pair (pairs: female connector 1 and 2, 3 and 4, 5 and 6 or 7 and 8) remains unused. When using pin 2 and pin 4 of a female connector, the operation of the second female connector is not permitted, as it may lead to incorrect signals.

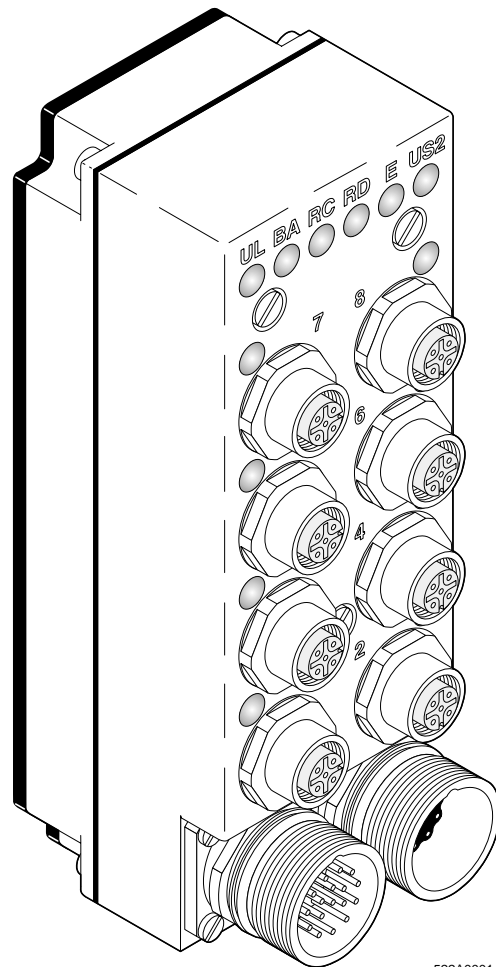

522A0001

Figure 1: IBS IP CDIO/R 24-8...

The IBS IP CDIO/R 24-8/SF module is a version of IBS IP CDIO/R 24-8 module. Differences are indicated in the data sheet.

IBS IP CDIO/R 24-8 and IBS IP CDIO/R 24-8/SF modules are designed for use in a special installation remote bus in which the power supply for the module electronics and the actuators is carried as well as two wire pairs for additional signals. In the special application on a welding robot, these are signals CCR and SCM.

The power supply for the bus logic (24 V DC) and for the actuators (24 V DC) is supplied to the robot controller in the hybrid cable and carried to the modules.

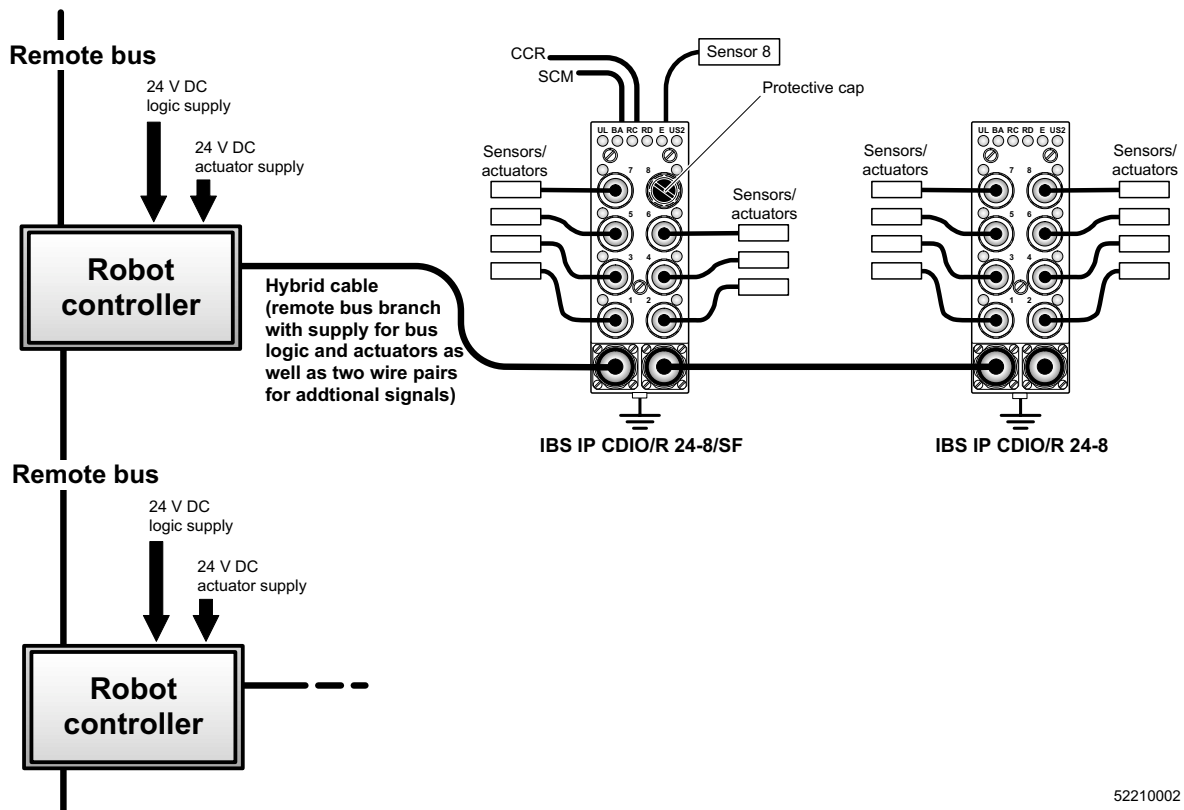

52210002

Figure 2: Electrical installation example for the IBS IP CDIO/R 24-8/SF module



Both modules can only be operated using a controller board with Generation 4.x firmware.



Cover unused female connectors with a protective cap to ensure IP 65 protection.

Connector Pin Assignment

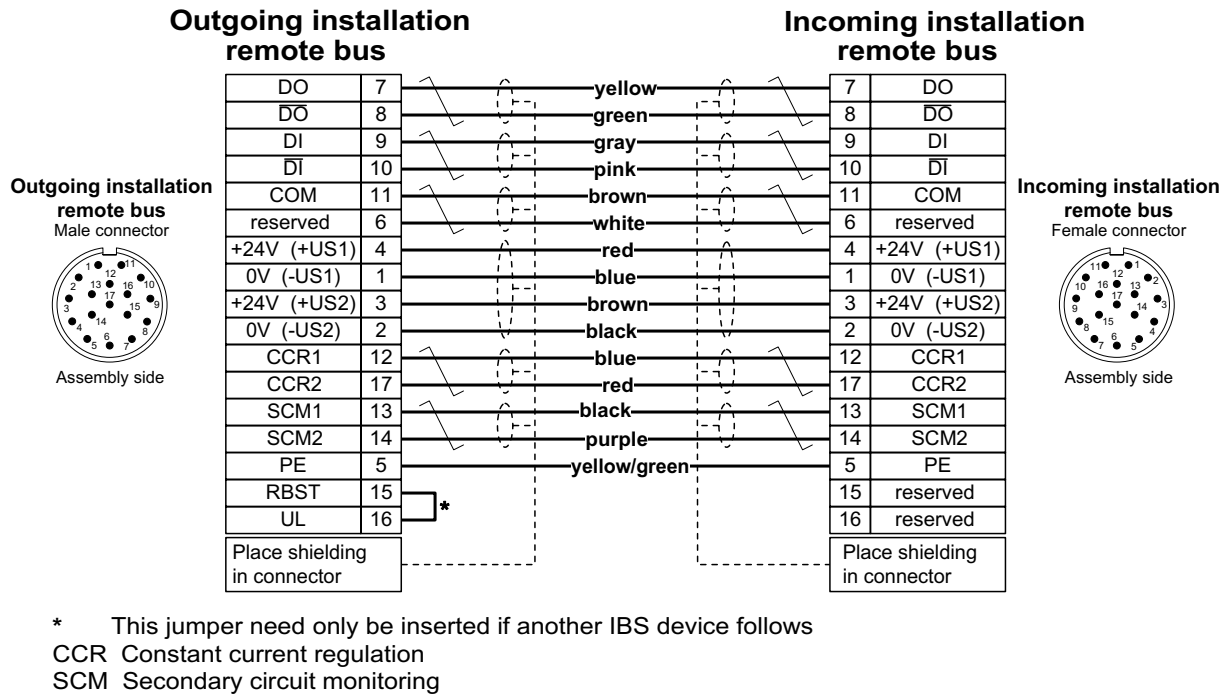

52210004

Figure 3: Connector pin assignment for the hybrid cable



- Do not mix up the terminals, as this may damage the electronics.
- Place the individual braided shields together and ensure the shield is fitted according to the manufacturers instructions.

Mounting the Installation Remote Bus

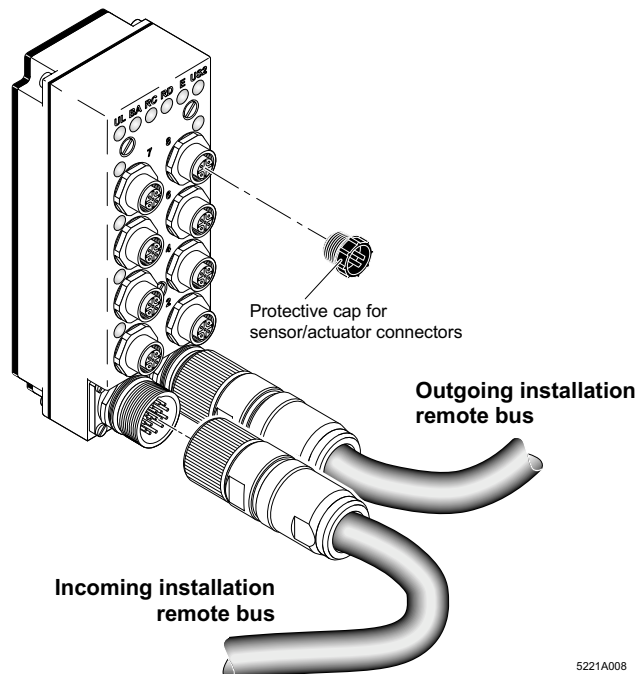

5221A008

Figure 4: Mounting the connecting cables

Connection of Inputs and Outputs

The I/O from each two channel connector is wired together in an X shape (see Figure 5). This means that there are two inputs/outputs available at one female connector. The input/output signal of the affected channels is available at pin 4, the signal of the corresponding channel is at pin 2.

If pin 2 is used (sensor or actuator with two signals), only one female connector may be connected per pair of channels. The corresponding female connector must remain unused and should be covered.

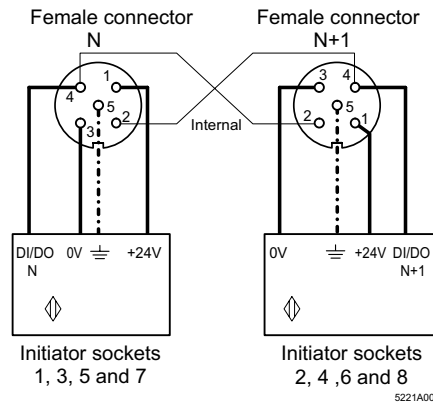

Figure 5: Channel pair

Table 1: Location and pin assignment of sensor/actuator sockets

		Connection number and position											
		1	2	3	4	5	6	7	8				
Sensor or actuator	with 1 signal	Supply	Pin 1	+24 V DC	+24 V DC	+24 V DC	+24 V DC	+24 V DC	+24 V DC	+24 V DC	+24 V DC	+24 V DC	
		Input/ Output	Pin 3	0 V	0 V	0 V	0 V	0 V	0 V	0 V	0 V	0 V	0 V
			Pin 5	⏏	⏏	⏏	⏏	⏏	⏏	⏏	⏏	⏏	⏏
	with 2 signals	Input/ Output	Pin 4	IN/OUT Bit 0	IN/OUT Bit 1	IN/OUT Bit 2	IN/OUT Bit 3	IN/OUT Bit 4	IN/OUT Bit 5	IN/OUT Bit 6	IN/OUT* Bit 7	IN/OUT Bit 6	
Pin 2			IN/OUT Bit 1	IN/OUT Bit 0	IN/OUT Bit 3	IN/OUT Bit 2	IN/OUT Bit 5	IN/OUT Bit 4	IN/OUT* Bit 7	IN/OUT Bit 6	IN/OUT Bit 6		
Position of the covered connector (when Pin 2 is used)													

5221A006

* In the IBS IP CDIO/R 24-8 module, channel 8 can be used in the same way as the other channels.

In the IBS IP CDIO/R 24-8/SF module, channel 8 is used only as an input and is permanently connected to the terminal block on the back of the module. It cannot be used as an additional input nor as an output. This also means that there is no output signal at pin 2 of channel 7.



Depending on the connector pin assignment, only the output **or** the input can be used for each channel.

Additional Signals

On the IBS IP CDIO/R 24-8/SF module, additional signals can be carried from the back of the module via spring-clamp terminals.

For the special application on a welding robot, this involves the following signals:

- Temperature of the welding transformer Permanently connected to input 8
- Signal for constant current regulation (CCR) Looped directly into the hybrid cable
- Signal for secondary circuit monitoring (SCM) Looped directly into the hybrid cable

Signal CCR is used to control the welding current. It is passed on to the welding controller by the welding transformer.

The input for the thermostatic switch is permanently connected to input 8.

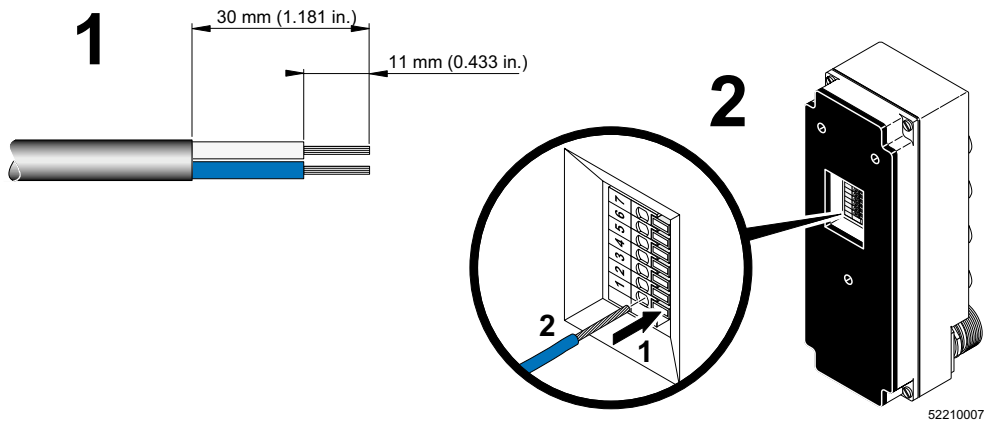

Figure 6: Terminal block on the back of the module

Table 2: Terminal assignment for the terminal block

Terminal	Signal
1	Initiator supply U_{INI}
2	IN 8
3	GND
4	Constant current regulation 1 (CCR1)
5	Constant current regulation 2 (CCR2)
6	Secondary circuit monitoring 1 (SCM1)
7	Secondary circuit monitoring 2 (SCM2)

In the IBS IP CDIO/R 24-8 module, this terminal block is not provided and signals CCR and SCM are looped through from the incoming to the outgoing remote bus.

Programming Data

Table 3: The most important data for programmers

ID code	3 _{dec} (03 _{hex})
Length code	81 _{hex}
Input address area	1 byte
Output address area	1 byte
PCP address area	0 bytes
Register length on the bus	1 byte

Housing Dimensions

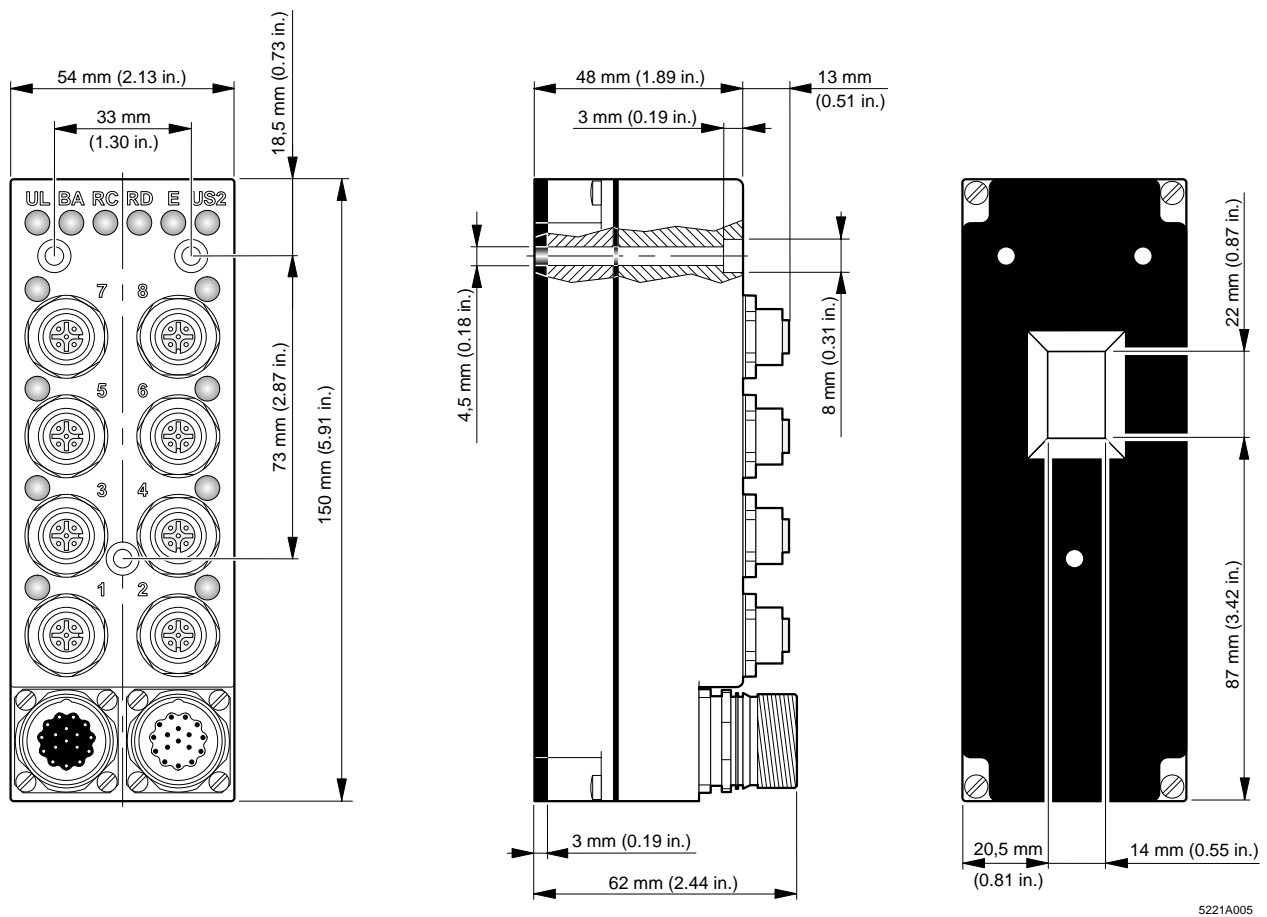

Figure 7: Housing dimensions for the IBS IP CDIO/R 24-8/SF module

The IBS IP CDIO/R 24-8 module has the same housing dimensions, but does not have an opening and seal on the back.

Technical Data

General Data

Type	IBS IP CDIO/R 24-8, IBS IP CDIO/R 24-8/SF
Ambient temperature	
- Operation	0°C to 55°C (32°F to 131°F)
- Storage/transport	-25°C to 70°C (-13°F to 158°F)
Humidity	
- Operation	75%, no condensation
- Storage/transport	95%, no condensation
Degree of protection	IP 65, when installed, unused slots should be covered with a protective cap
Electrical isolation between	- I/O - Bus logic with a test voltage of 500 V AC, 1 min
Housing	
- Dimensions (length x width x height)	150 mm x 54 mm x 48 mm (5.906 in. x 2.126 in. x 1.890 in.)

Supply Voltages

Bus voltage U_{S1}	
Nominal voltage	24 V DC
Permissible range	18.5 V DC to 30.5 V DC (ripple included)
Ripple	3.6 V _{pp}
Current consumption	Approximately 120 mA plus initiator current

The voltage U_{S1} is looped through and can be tapped off at the connector for the outgoing remote bus. The maximum continuous current is 4.5 A.

Initiator voltage U_{INI}	
Nominal voltage	U_{S1} minus 1 V
Current consumption	40 mA total current for all inputs (5 mA per input)
Protection by fuses	Electronic overload/ short circuit protection

Actuator voltage U_{S2}	
Nominal voltage	24 V DC
Permissible range	18.5 V DC to 30.5 V DC (ripple included)
Ripple	3.6 V _{pp}
Current consumption	3.5 A, maximum (IBS IP CDIO/R 24-8/SF) 4.0 A, maximum (IBS IP CDIO/R 24-8)

The voltage U_{S2} is looped through and can be tapped off at the connector for the outgoing remote bus. The maximum continuous current is 7.0 A.

INTERBUS Interface

Interface type	Two-wire installation remote bus; Differential signal lines, twisted in pairs
Connection technology	IP 65 circular connector
Connector pin assignment	See Figure 3

Digital Inputs

Number of inputs	7+1 (IBS IP CDIO/R 24-8/SF) 8 (IBS IP CDIO/R 24-8)
Electrical isolation	Yes, for bus logic Test voltage 500 V AC, 50 Hz, 1 min.
Input voltage	According to DIN 19240
- Permissible range 0 signal	-30 V to +5 V
- Permissible range 1 signal	+13 V to +30 V
Input current	5 mA at 24 V, typical
Permissible residual current 0 signal	1.5 mA
Delay time 0 -> 1	3 ms, typical
Delay time 1 -> 0	3 ms, typical

Digital Input for Thermostatic Switch (for IBS IP CDIO/R 24-8/SF Only)

The digital input for the thermostatic switch of the welding transformer is on the back of the module and can be accessed through the ground plate. It is permanently connected to input 8.

Connection method	Spring-clamp terminal 0.13 - 0.5 mm ² (26 - 20 AWG)
-------------------	---

Digital Outputs

Number of outputs	8 (IBS IP CDIO/R 24-8) 7 (IBS IP CDIO/R 24-8/SF)
Min. output voltage at nominal current	U _{S2} minus 1 V
Nominal current per channel	0.5 A electronically short circuit-proof
Concurrent channel derating	0.5
Derating	All outputs can be on at maximum current without exceeding housing maximum power dissipation.
Protective functions	Electronic short circuit protection Free running circuit
Short circuit current protection	< 2 A
Limitation of the voltage induced on circuit interruption	Approximately -20 V
Protection against ground connection interruption	Yes
Max. leakage current at 0 signal	≤0.8 mA (according to DIN VDE 19240)
Electrical isolation	Yes, for bus logic Test voltage 500 V AC, 50 Hz, 1 min.

Module Error Messages

- Short circuit/overload of the initiator supply
- Short circuit/overload of the output

Status and Diagnostic Indicators

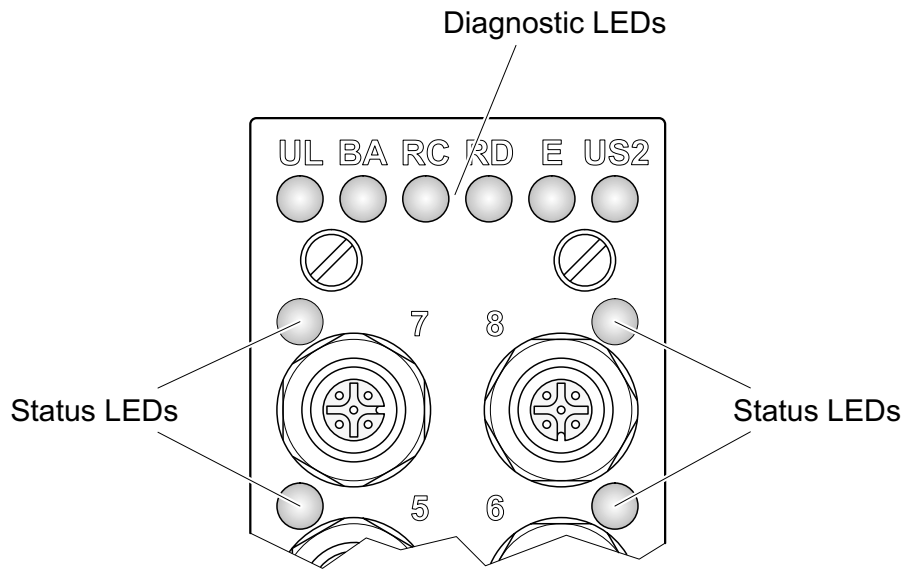

52210009

Figure 8: Arrangement of LEDs

Table 4: Diagnostic and status LEDs per remote bus line

UL	Green LED ON: OFF:	Module electronics supply voltage Supply voltage present Supply voltage not present - Internal power supply unit for the logic voltage is defective
BA	Green LED ON: OFF:	Bus active Data transmission on INTERBUS active No data transmission
RC	Green LED ON: OFF:	Remote bus cable check Incoming remote bus cable connected Incoming remote bus cable not connected or defective
RD	Red LED ON:	Remote bus status (Remote Bus Disabled) Outgoing remote bus shut down
E	Red LED ON:	Group error message short circuit/overload An error occurred - Short circuit/overload on initiator voltage - Short circuit/overload on outputs
US2	Green LED ON: OFF:	I/O supply voltage Supply voltage present Supply voltage not present
Status	Yellow (red) LED Yellow: Red:	Status per input/output Status per input/output Short circuit/overload of the output

EMC

Emitted interference according to EN 55011	Class A, industrial area
Noise immunity according to	
- ENV 50140, radiated-noise immunity	10 V/m
- ENV 50141, conducted noise immunity	10 V
- EN 61000-4-2 (ESD), Criterion 2	6 kV contact discharge
- EN 61000-4-4 (Burst), Criterion 2	4 kV (power supply) 2 kV (signal lines)
- EN 61000-4-5 (Surge), Criterion 3	0.5 kV symm./asymm. (power supply) 1 kV symm., 2 kV asymm. (signal lines)

Mechanical Capability

Vibration according to IEC 68-2-6 operation	5 g, Criterion 1
Shock according to IEC 68-2-27	15 g

Ordering Data

Table 5: Ordering data

Description	Type	Order No.
Digital I/O module	IBS IP CDIO/R 24-8/SF	27 19 56 4
Digital I/O module	IBS IP CDIO/R 24-8	27 19 46 7
Protective caps (5 pcs.) for unused sensor/actuator sockets	IBS IP PROT IO	27 59 91 9
Protective caps for unused outgoing installation remote bus sockets	MSK 2	16 65 90 7
Crimping pliers	Crimpfox RC 2.5	12 05 44 8
Remote bus connector:		
Male connector, straight	TGGM/CDIO/17-ST	16 67 89 5
Female connector, straight	TGGM/CDIO/17-BU	16 67 90 5
Male connector, angled	TWGM/CDIO/17-ST	16 67 95 0
Female connector, angled	TWGM/CDIO/17-BU	16 67 96 3

Table 6: Assignment of inputs for IBS IP CDIO/R 24-8/SF and IBS IP CDIO/R 24-8 modules to the addresses of various control or computer systems

IBM PC IBS PC ISA SC/I-T	Word access	E.g.: W 16															
	Bit	16.15	16.14	16.13	16.12	16.11	16.10	16.9	16.8	16.7	16.6	16.5	16.4	16.3	16.2	16.1	16.0
Siemens S5 IBS S5 DSC/I-T	Word access	E.g.: IW 16															
	Bit	16.15	16.14	16.13	16.12	16.11	16.10	16.9	16.8	16.7	16.6	16.5	16.4	16.3	16.2	16.1	16.0
	Byte access	E.g.: IB 16								E.g.: IB 17							
	Bit	16.7	16.6	16.5	16.4	16.3	16.2	16.1	16.0	17.7	17.6	17.5	17.4	17.3	17.2	17.1	17.0
Module	Sensor	8	7	6	5	4	3	2	1	This address area is not used.							
INTERBUS reference	Word	E.g.: W16															
	Bit	16.15	16.14	16.13	16.12	16.13	16.10	16.9	16.8	16.7	16.6	16.5	16.4	16.3	16.2	16.1	16.0

Table 7: Assignment of outputs for IBS IP CDIO/R 24-8/SF(*) and IBS IP CDIO/R 24-8(**) modules to the addresses of various control or computer systems

IBM PC IBS PC ISA SC/I-T	Word access	E.g.: W 16															
	Bit	16.15	16.14	16.13	16.12	16.11	16.10	16.9	16.8	16.7	16.6	16.5	16.4	16.3	16.2	16.1	16.0
Siemens S5 IBS S5 DSC/I-T	Word access	E.g.: QW 16															
	Bit	16.15	16.14	16.13	16.12	16.11	16.10	16.9	16.8	16.7	16.6	16.5	16.4	16.3	16.2	16.1	16.0
	Byte access	E.g.: QB 16								E.g.: QB 17							
	Bit	16.7	16.6	16.5	16.4	16.3	16.2	16.1	16.0	17.7	17.6	17.5	17.4	17.3	17.2	17.1	17.0
Module	Actuator	-*/8**	7	6	5	4	3	2	1	This address area is not used.							
INTERBUS reference	Word	E.g.: W16															
	Bit	16.15	16.14	16.13	16.12	16.13	16.10	16.9	16.8	16.7	16.6	16.5	16.4	16.3	16.2	16.1	16.0



When several modules are used in combination with one of the above controller boards, the addresses of two or more modules can be combined in one word per data direction. This avoids gaps in the address area of the control or computer system. Addressing by the user (user-defined combination) and default addressing by the control system (automatic combination) have to be differentiated:

User-Defined Combination of Module Address Areas:

You can set the address area or parts of the address area of a module to any address of the control or computer system. Byte limits must not be exceeded.

Modules can be distributed anywhere in the INTERBUS ring.

Automatic Combination of the Address Areas of Modules in One Word (Automatic Filling of Words) With the Generation 4 Firmware:

When combining automatically, the firmware groups together the address areas of consecutive modules with the same data direction according to the following principles:

- Two consecutive modules on the INTERBUS ring with up to four bits are grouped together in one byte.
The first module occupies the lower bits of the byte, the second module occupies the higher bits. In a word the higher byte is occupied first.
- Each byte module occupies a new byte address.
The higher byte is occupied first (see Tables 6 and 7).
- Each word module occupies a new word address.

Компания «Океан Электроники» предлагает заключение долгосрочных отношений при поставках импортных электронных компонентов на взаимовыгодных условиях!

Наши преимущества:

- Поставка оригинальных импортных электронных компонентов напрямую с производств Америки, Европы и Азии, а так же с крупнейших складов мира;
- Широкая линейка поставок активных и пассивных импортных электронных компонентов (более 30 млн. наименований);
- Поставка сложных, дефицитных, либо снятых с производства позиций;
- Оперативные сроки поставки под заказ (от 5 рабочих дней);
- Экспресс доставка в любую точку России;
- Помощь Конструкторского Отдела и консультации квалифицированных инженеров;
- Техническая поддержка проекта, помощь в подборе аналогов, поставка прототипов;
- Поставка электронных компонентов под контролем ВП;
- Система менеджмента качества сертифицирована по Международному стандарту ISO 9001;
- При необходимости вся продукция военного и аэрокосмического назначения проходит испытания и сертификацию в лаборатории (по согласованию с заказчиком);
- Поставка специализированных компонентов военного и аэрокосмического уровня качества (Xilinx, Altera, Analog Devices, Intersil, Interpoint, Microsemi, Actel, Aeroflex, Peregrine, VPT, Syfer, Eurofarad, Texas Instruments, MS Kennedy, Miteq, Cobham, E2V, MA-COM, Hittite, Mini-Circuits, General Dynamics и др.);

Компания «Океан Электроники» является официальным дистрибьютором и эксклюзивным представителем в России одного из крупнейших производителей разъемов военного и аэрокосмического назначения «JONHON», а так же официальным дистрибьютором и эксклюзивным представителем в России производителя высокотехнологичных и надежных решений для передачи СВЧ сигналов «FORSTAR».



JONHON

«JONHON» (основан в 1970 г.)

Разъемы специального, военного и аэрокосмического назначения:

(Применяются в военной, авиационной, аэрокосмической, морской, железнодорожной, горно- и нефтедобывающей отраслях промышленности)

«FORSTAR» (основан в 1998 г.)

ВЧ соединители, коаксиальные кабели,
кабельные сборки и микроволновые компоненты:

(Применяются в телекоммуникациях гражданского и специального назначения, в средствах связи, РЛС, а так же военной, авиационной и аэрокосмической отраслях промышленности).



Телефон: 8 (812) 309-75-97 (многоканальный)

Факс: 8 (812) 320-03-32

Электронная почта: ocean@oceanchips.ru

Web: <http://oceanchips.ru/>

Адрес: 198099, г. Санкт-Петербург, ул. Калинина, д. 2, корп. 4, лит. А