

8-Channel Analog Volume Control

Features

- ◆ Complete Analog Volume Control
 - 8 Independently Controllable Channels
 - 3 Configurable Master Volume and Muting Controls
- ◆ Wide Adjustable Volume Range
 - -96 dB to +22 dB in ¼ dB Steps
- ◆ Low Distortion & Noise
 - -112 dB THD+N
 - 127 dB Dynamic Range
- ◆ Noise-Free Level Transitions
 - Zero-Crossing Detection with Programmable Time-Out
- ◆ Low Channel-to-Channel Crosstalk
 - 120 dB Inter-Channel Isolation
- ◆ Comprehensive Serial Control Port
 - Supports I²C® and SPI™ Communication
 - Independent Control of up to 128 Devices on a Shared 2-Wire I²C or 3-Wire SPI Control Bus
 - Supports Individual and Grouped Control of all CS3318 Devices on the I²C or SPI Control Bus
- ◆ Flexible Power Supply Voltages
 - ±8 V to ±9 V Analog Supply
 - +3.3 V Digital Supply

Description

The CS3318 is an 8-channel digitally controlled analog volume control designed specifically for high-end audio systems. It features a comprehensive I²C/SPI serial control port for easy device and volume configuration.

The CS3318 includes arrays of well-matched resistors and complementary low-noise active output stages. A total adjustable range of 118 dB, in ¼ dB steps, is spread evenly over 96 dB of attenuation and 22 dB of gain.

The CS3318 implements configurable zero-crossing detection to provide glitch-free volume-level changes.

The I²C/SPI control interface provides for easy system integration of up to 128 CS3318 devices over a single 2-wire I²C or 3-wire SPI bus, allowing many channels of volume control with minimal system controller I/O requirements. Devices may be controlled on an individual and grouped basis, simplifying simultaneous configuration of a group of channels across multiple devices, while allowing discrete control over all channels on an individual basis.

The device operates from ±8 V to ±9 V analog supplies and has an input/output voltage range of ±6.65 V to ±7.65 V. The digital control interface operates at +3.3 V.

The CS3318 is available in a 48-pin LQFP package in Commercial grade (-10° to 70° C). The CS3318 Customer Demonstration board is also available for device evaluation. Refer to [“Ordering Information” on page 44](#) for complete details.

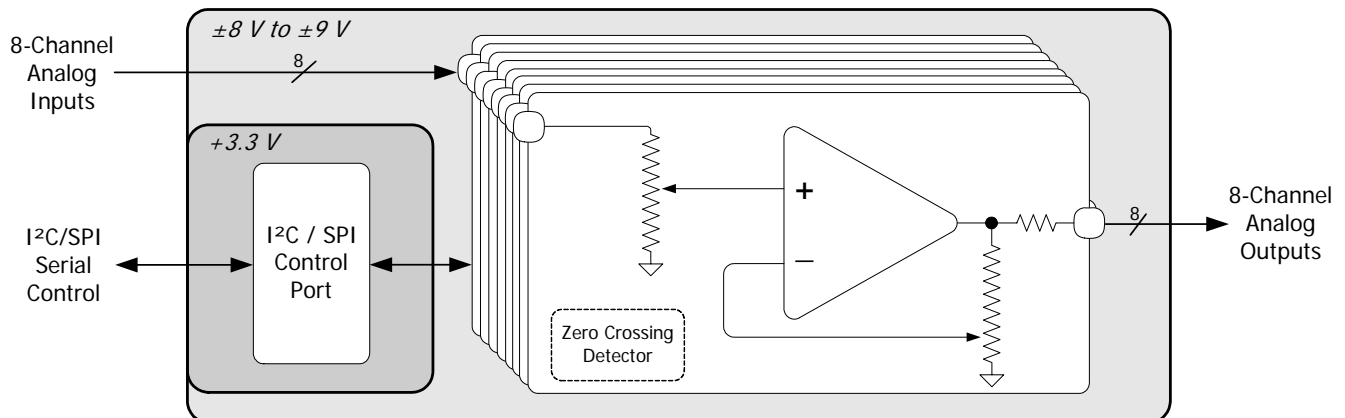

TABLE OF CONTENTS

1. PIN DESCRIPTIONS	5
2. CHARACTERISTICS AND SPECIFICATIONS	7
SPECIFIED OPERATING CONDITIONS	7
ABSOLUTE MAXIMUM RATINGS.....	7
ANALOG CHARACTERISTICS	8
DIGITAL INTERFACE CHARACTERISTICS.....	9
MUTE SWITCHING CHARACTERISTICS	9
CONTROL PORT SWITCHING CHARACTERISTICS - I ² C FORMAT	10
CONTROL PORT SWITCHING CHARACTERISTICS - SPI™ FORMAT	11
3. TYPICAL CONNECTION DIAGRAM	12
4. DETAILED BLOCK DIAGRAM	13
5. APPLICATIONS	14
5.1 General Description	14
5.2 System Design	14
5.2.1 Analog Inputs	14
5.2.2 Analog Outputs	15
5.2.3 Recommended Layout, Grounding, and Power Supply Decoupling	15
5.3 Power-Up and Power-Down	15
5.3.1 Recommended Power-Up Sequence	16
5.3.2 Recommended Power-Down Sequence	16
5.4 Volume & Muting Control Architecture	17
5.4.1 Control Mapping Matrix	17
5.4.2 Volume & Muting Control Implementation	18
5.5 Volume Controls	19
5.5.1 Individual Channel Volume Controls	19
5.5.2 Master Volume Controls	19
5.5.3 Volume Limits	20
5.6 Muting Controls	21
5.6.1 Individual Channel Mute Controls	21
5.6.2 Master Mute Controls	21
5.6.3 Hardware Mute Control	21
5.7 Zero-Crossing Detection	22
5.7.1 Zero-Crossing Modes	22
5.7.2 Zero-Crossing Time-Out	22
5.8 System Serial Control Configuration	23
5.8.1 Serial Control within a Single-CS3318 System	23
5.8.2 Serial Control within a Multiple-CS3318 System	24
5.8.2.1 SPI Mode Serial Control Configuration	24
5.8.2.2 I ² C Mode Control Configuration	26
5.9 I ² C/SPI Serial Control Formats	27
5.9.1 I ² C Mode	27
5.9.2 SPI Mode	28
6. CS3318 REGISTER QUICK REFERENCE	29
7. CS3318 REGISTER DESCRIPTIONS	31
7.1 Ch 1-8 Volume - Addresses 01h - 08h	31
7.1.1 Volume Control (Bits 7:0)	31
7.2 ¼ dB Control - Address 09h	32
7.2.1 ¼ dB Control (Bit 0 - 7)	32
7.3 Mute Control - Address 0Ah	33
7.3.1 Mute Channel X (Bit 0 - 7)	33
7.4 Device Configuration 1 - Address 0Bh (Bit 5)	33
7.4.1 Enable MUTE Input (Bit 5)	33

7.4.2 MUTE Input Polarity (Bit 4)	33
7.4.3 Channel B = Channel A (Bit 0 - 3)	34
7.5 Device Configuration 2 - Address 0Ch	34
7.5.1 Zero-Crossing Time-Out Period (Bits 4:2)	34
7.5.2 Zero-Crossing Mode (Bits 1:0)	35
7.6 Channel Power - Address 0Dh	35
7.6.1 Power Down Channel X (Bit 0 - 7)	35
7.7 Master Power - Address 0Eh	35
7.7.1 Power Down All (Bit 0)	35
7.8 Freeze Control - Address 0Fh	36
7.8.1 Freeze (Bit 7)	36
7.9 Master 1 Mask - Address 10h	36
7.10 Master 1 Volume - Address 11h	36
7.10.1 Master 1 Volume Control (Bits 7:0)	36
7.11 Master 1 Control - Address 12h	37
7.11.1 Master 1 Mute (Bit 1)	37
7.11.2 Master 1 ¼ dB Control (Bit 0)	37
7.12 Master 2 Mask - Address 13h	37
7.13 Master 2 Volume - Address 14h	37
7.13.1 Master 2 Volume Control (Bits 7:0)	37
7.14 Master 2 Control - Address 15h	38
7.14.1 Master 2 Mute (Bit 1)	38
7.14.2 Master 2 ¼ dB Control (Bit 0)	38
7.15 Master 3 Mask - Address 16h	38
7.16 Master 3 Volume - Address 17h	38
7.16.1 Master 3 Volume Control (Bits 7:0)	38
7.17 Master 3 Control - Address 18h	39
7.17.1 Master 3 Mute (Bit 1)	39
7.17.2 Master 3 ¼ dB Control (Bit 0)	39
7.18 Group 2 Chip Address 19h	40
7.18.1 Group 2 Chip Address (Bits 7:1)	40
7.18.2 Enable Group 2 Address (Bit 0)	40
7.19 Group 1 Chip Address 1Ah	40
7.19.1 Group 1 Chip Address (Bits 7:1)	40
7.19.2 Enable Group 1 Address (Bit 0)	40
7.20 Individual Chip Address 1Bh	41
7.20.1 Individual Chip Address (Bits 7:1)	41
7.20.2 Enable Next Device (Bit 0)	41
7.21 Chip ID - Address 1Ch	41
7.21.1 Chip ID (Bits 7:4)	41
7.21.2 Chip Revision (Bits 3:0)	41
8. PARAMETER DEFINITIONS	42
9. PACKAGE DIMENSIONS	43
10. THERMAL CHARACTERISTICS AND SPECIFICATIONS	43
11. ORDERING INFORMATION	44
12. REVISION HISTORY	44

LIST OF FIGURES

Figure 1. Control Port Timing - I ² C Format.....	10
Figure 2. Control Port Timing - SPI Format.....	11
Figure 3. Typical Connection Diagram.....	12
Figure 4. Detailed Block Diagram	13
Figure 5. CS3318 Control Mapping Matrix.....	17
Figure 6. Volume & Muting Control Implementation	18
Figure 7. Standard I ² C Connections.....	23
Figure 8. Standard SPI Connections.....	23
Figure 9. SPI Serial Control Connections	24
Figure 10. Individual Device Address Configuration Process	25
Figure 11. I ² C Serial Control Connections	26
Figure 12. Control Port Timing, I ² C Write.....	27
Figure 13. Control Port Timing, I ² C Read.....	28
Figure 14. SPI Write Cycle.....	28

LIST OF TABLES

Table 1. Example Volume Settings	20
Table 2. Zero-Crossing Modes.....	22
Table 3. Zero-Crossing Time-Out Periods	22
Table 4. I ² C Mode Default Chip Address	27
Table 5. Example Volume Settings	31
Table 6. Example Volume Settings	32
Table 7. Channel B = Channel A Settings	34
Table 8. Zero-Crossing Time-Out Settings	34
Table 9. Zero-Crossing Mode Settings	35
Table 10. Chip Revision Register Codes	41

1. PIN DESCRIPTIONS

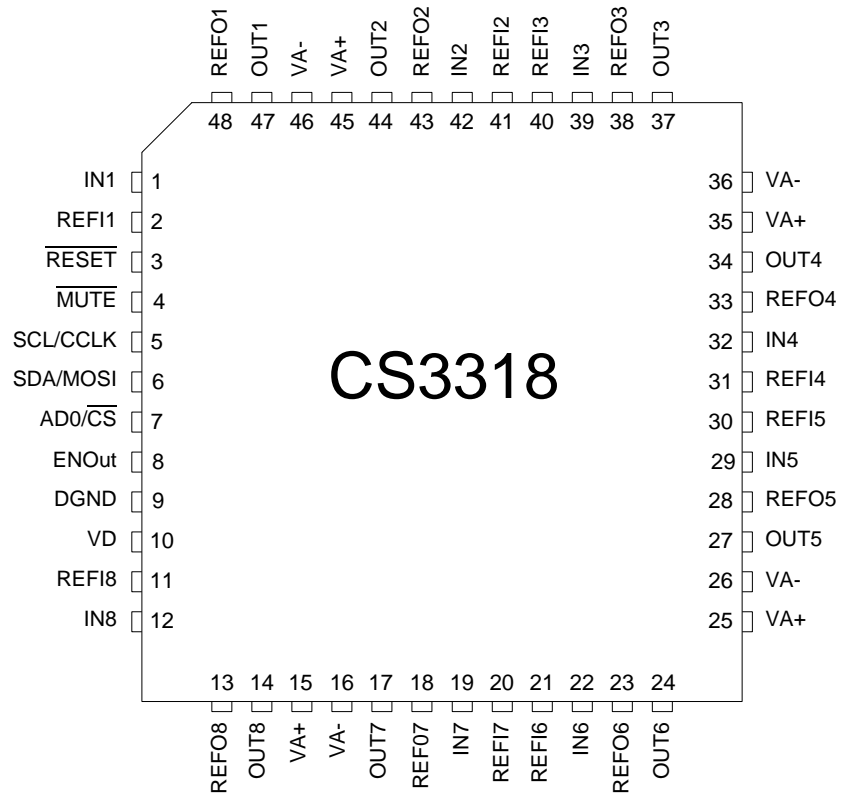

Pin Name	#	Pin Description
IN1	1	
IN2	42	
IN3	39	
IN4	32	Analog Inputs (Input) - The full-scale level is specified in the Analog Characteristics specification table.
IN5	29	
IN6	22	
IN7	19	
IN8	12	

Pin Name	#	Pin Description
OUT1	47	
OUT2	44	
OUT3	37	
OUT4	34	Analog Outputs (Output) - The full-scale output level is specified in the Analog Characteristics specification table.
OUT5	27	
OUT6	24	
OUT7	17	
OUT8	14	
REFI1	2	Reference In (Input) - Analog reference pin.
REFI2	41	
REFI3	40	
REFI4	31	
REFI5	30	
REFI6	21	
REFI7	20	
REFI8	11	
REFO1	48	Reference Out (Output) - Analog reference pin.
REFO2	43	
REFO3	38	
REFO4	33	
REFO5	28	
REFO6	23	
REFO7	18	
REFO8	13	
VA+	15, 25, 35, 45	Positive Analog Power (Input) - Positive power for the internal analog section.
VA-	16, 26, 36, 46	Negative Analog Power (Input) - Negative power for the internal analog section.
RESET	3	Reset (Input) - The device enters a low-power mode when this pin is driven low.
MUTE	4	Mute (Input) - This pin defaults to an active low mute input, and may be configured as an active high mute input.
SCL/CCLK	5	Serial Control Port Clock (Input) - Serial clock for the serial control port.
SDA/MOSI	6	Serial Control Data (Input/Output) - SDA is a data I/O line for the control port interface in I ² C Mode. MOSI is the input data line for the control port interface in SPI Mode.
AD0/ $\overline{\text{CS}}$	7	Default Address Bit 0 (I²C) / Control Port Chip Select (SPI) (Input) - AD0 sets the LSB of the default chip address in I ² C Mode. CS is the chip-select signal for SPI format.
ENOut	8	Enable Output (Output) - Enable output signal for multi-device serial control chain configuration.
DGND	9	Digital Ground (Input) - Ground reference for the internal digital section.
VD	10	Digital Power (Input) - Positive power for the internal digital section.

2. CHARACTERISTICS AND SPECIFICATIONS

All Min/Max characteristics and specifications are guaranteed over the Specified Operating Conditions. Typical performance characteristics and specifications are derived from measurements taken at nominal supply voltages and $T_A = 25^\circ\text{C}$.

SPECIFIED OPERATING CONDITIONS

(DGND = 0 V; All voltages with respect to ground.)

Parameters	Symbol	Min	Nom	Max	Units	
DC Power Supplies:	Positive Analog	VA+	7.6	9.0	9.45	V
	Negative Analog	VA-	-9.45	-9.0	-7.6	V
	Digital	VD	3.1	3.3	3.5	V
Ambient Operating Temperature (Power Applied)	T_A	-10	-	+70	$^\circ\text{C}$	

ABSOLUTE MAXIMUM RATINGS

(DGND = 0 V; All voltages with respect to ground. [\(Note 1\)](#))

Parameter	Symbol	Min	Max	Units	
DC Power Supplies:	Positive Analog	VA+	-0.3	10.5	V
	Negative Analog	VA-	-10.5	0.3	V
	Digital	VD	-0.3	3.63	V
Input Current	(Note 2)	I_{in}	-	± 10	mA
Analog Input Voltage	V_{INA}	(VA-) - 0.3	(VA+) + 0.3	V	
Digital Input Voltage	V_{IND}	VD - 0.3	VD + 0.3	V	
Ambient Operating Temperature (Power Applied)	T_A	-55	+125	$^\circ\text{C}$	
Storage Temperature	T_{stg}	-65	+150	$^\circ\text{C}$	

Notes:

1. Operation beyond these limits may result in permanent damage to the device. Normal operation is not guaranteed at these extremes.
2. Any pin except supplies. Transient currents of up to ± 100 mA on the analog input pins will not cause SCR latch-up.

ANALOG CHARACTERISTICS

(Test conditions (unless otherwise specified): $R_S = 0$; $R_L = 20\text{ k}\Omega$; $C_L = 20\text{ pF}$; 10 Hz to 20 kHz Measurement Bandwidth)

Parameter	Symbol	Min	Typ	Max	Unit	
DC Characteristics						
Step Size		-	0.25	-	dB	
Gain Error (Vol = +22 dB)		-	±0.5	-	dB	
Gain Matching Between Channels (Vol = +22 dB)		-	±0.1	-	dB	
Input Resistance	R_{IN}	8	10	-	k Ω	
Input Capacitance	C_{IN}	-	10	-	pF	
AC Characteristics						
Total Harmonic Distortion + Noise (Note 3)	THD+N	-	0.00025	0.00063	%	
Dynamic Range		121	127	-	dB	
Input/Output Voltage Range (THD+N < 1 %)	V_{FS}	(VA-) + 1.35	-	(VA+) - 1.35	V	
Output Noise (Note 4)		-	1.8	3.6	μV_{rms}	
Interchannel Isolation (1 kHz)		-	-120	-	dB	
Output Buffer						
Offset Voltage (Note 4)	V_{OS}	-	0.75	5	mV	
Output Resistance	R_{OUT}	-	100	-	Ω	
AC Load Resistance	R_{LOAD}	2	-	-	k Ω	
Load Capacitance		-	-	100	pF	
Short Circuit Current		-	20	-	mA	
Unity Gain Bandwidth, Small Signal		-	5	-	MHz	
Power Supplies						
Supply Current (No Load, $V_{in} = 0\text{ V}$)	Normal Operation	I_{VA+}	-	36	50	mA
		I_{VA-}	-	36	50	mA
		I_{VD}	-	0.6	1.07	mA
	Power-Down, All Supplies (Note 5)	I_{PD}	-	60	-	μA
Power Consumption	Normal Operation		-	650	904	mW
	Power Down (Note 5)		-	540	-	μW
Power Supply Rejection Ratio (250 Hz)	PSRR	-	80	-	dB	

- $V_{in} = [(V_{FS\ Max} - V_{FS\ Min}) - 1.6\text{ V}] V_{p-p}$, 1 kHz, Volume = 0 dB.
Note that for (VA+) = -(VA-) = 9 V, $V_{in} = 13.7\text{ V}_{p-p} = 4.8\text{ V}_{RMS}$.
- Measured with input grounded and volume = 0 dB. Will increase as a function of volume settings >0 dB.
- Power-down is defined as $\overline{RESET} = \text{low}$, all clock and data lines held static, and no analog input signals applied.

DIGITAL INTERFACE CHARACTERISTICS

Parameters	Symbol	Min	Typ	Max	Units
High-Level Input Voltage	V_{IH}	$0.7 \times VD$	-	-	V
Low-Level Input Voltage	V_{IL}	-	-	$0.2 \times VD$	V
High-Level Output Voltage at $I_o=2$ mA	V_{OH}	$VD - 1.0$	-	-	V
Low-Level Output Voltage at $I_o=2$ mA	V_{OL}	-	-	0.4	V
Input Leakage Current	I_{in}	-	-	± 10	μA
Input Capacitance		-	8	-	pF

MUTE SWITCHING CHARACTERISTICS

(Inputs: Logic 0 = DGND, Logic 1 = VD)

Parameters	Symbol	Min	Typ	Max	Units
\overline{MUTE} Active Pulse Width (Note 6)	-	2	-	-	ms

- The \overline{MUTE} active state (low/high) is set by the MutePolarity bit in the Device Configuration 1 register (see [page 33](#)).

CONTROL PORT SWITCHING CHARACTERISTICS - I²C FORMAT

(Inputs: Logic 0 = DGND, Logic 1 = VD, C_L = 20 pF)

Parameter	Symbol	Min	Max	Unit
SCL Clock Frequency	f _{scl}	-	100	kHz
RESET Rising Edge to Start	t _{irs}	100	-	ns
Bus Free Time Between Transmissions	t _{buf}	4.7	-	μs
Start Condition Hold Time (prior to first clock pulse)	t _{hdst}	4.0	-	μs
Clock Low time	t _{low}	4.7	-	μs
Clock High Time	t _{high}	4.0	-	μs
Setup Time for Repeated Start Condition	t _{sust}	4.7	-	μs
SDA Hold Time from SCL Falling (Note 7)	t _{hdd}	0	-	μs
SDA Setup time to SCL Rising	t _{sud}	250	-	ns
Rise Time of SCL and SDA	t _{rc} , t _{rd}	-	1	μs
Fall Time SCL and SDA	t _{fc} , t _{fd}	-	300	ns
Setup Time for Stop Condition	t _{susp}	4.7	-	μs
Acknowledge Delay from SCL Falling	t _{ack}	300	1000	ns

7. Data must be held for sufficient time to bridge the transition time, t_{fc}, of SCL.

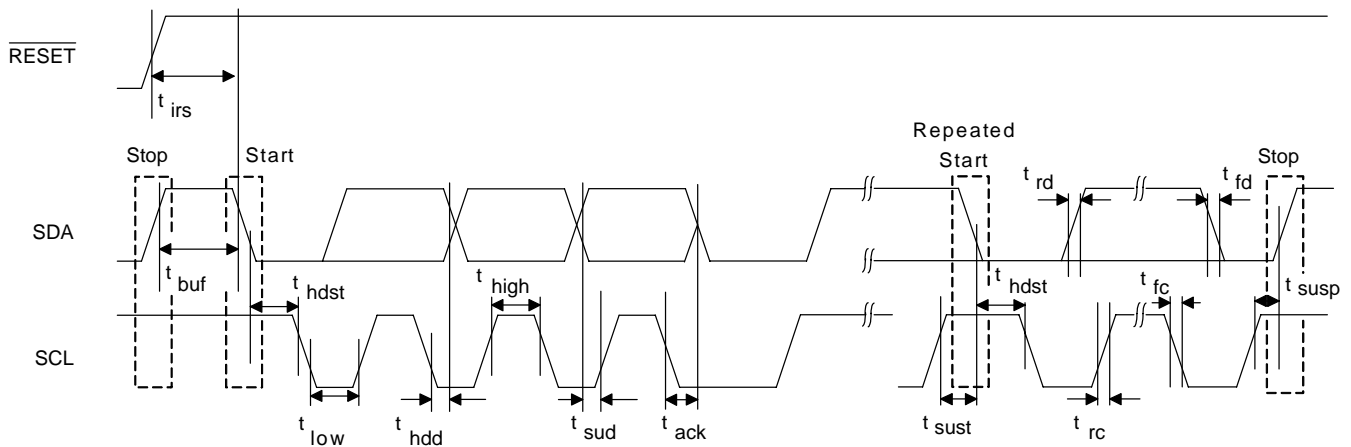

Figure 1. Control Port Timing - I²C Format

CONTROL PORT SWITCHING CHARACTERISTICS - SPI™ FORMAT

(Inputs: Logic 0 = DGND, Logic 1 = VD, $C_L = 20$ pF)

Parameter	Symbol	Min	Max	Unit
CCLK Clock Frequency	f_{sck}	0	6.0	MHz
RESET Rising Edge to \overline{CS} Falling	t_{srs}	100	-	ns
\overline{CS} High Time Between Transmissions	t_{csh}	1.0	-	μ s
\overline{CS} Falling to CCLK Edge	t_{css}	20	-	ns
CCLK Low Time	t_{scl}	66	-	ns
CCLK High Time	t_{sch}	66	-	ns
CDIN to CCLK Rising Setup Time	t_{dsu}	40	-	ns
CCLK Rising to DATA Hold Time	t_{dh}	15	-	ns
Rise Time of CCLK and CDIN	t_{r2}	-	100	ns
Fall Time of CCLK and CDIN	t_{f2}	-	100	ns

8. Data must be held for sufficient time to bridge the transition time of CCLK.
9. For $f_{sck} < 1$ MHz.

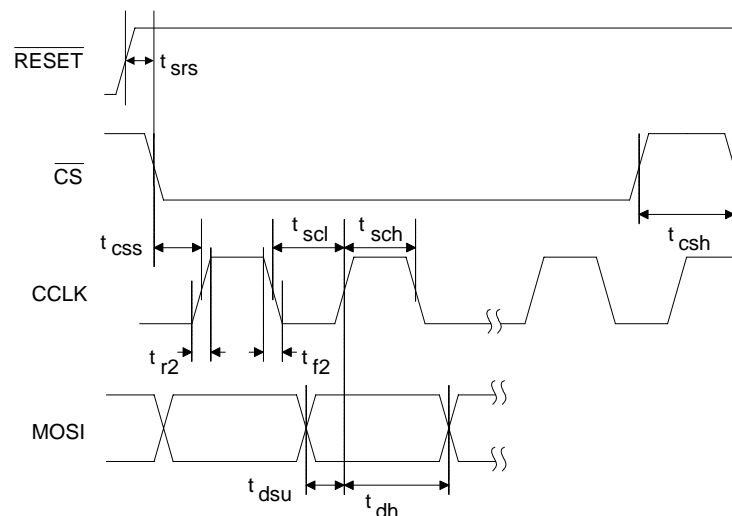

Figure 2. Control Port Timing - SPI Format

3. TYPICAL CONNECTION DIAGRAM

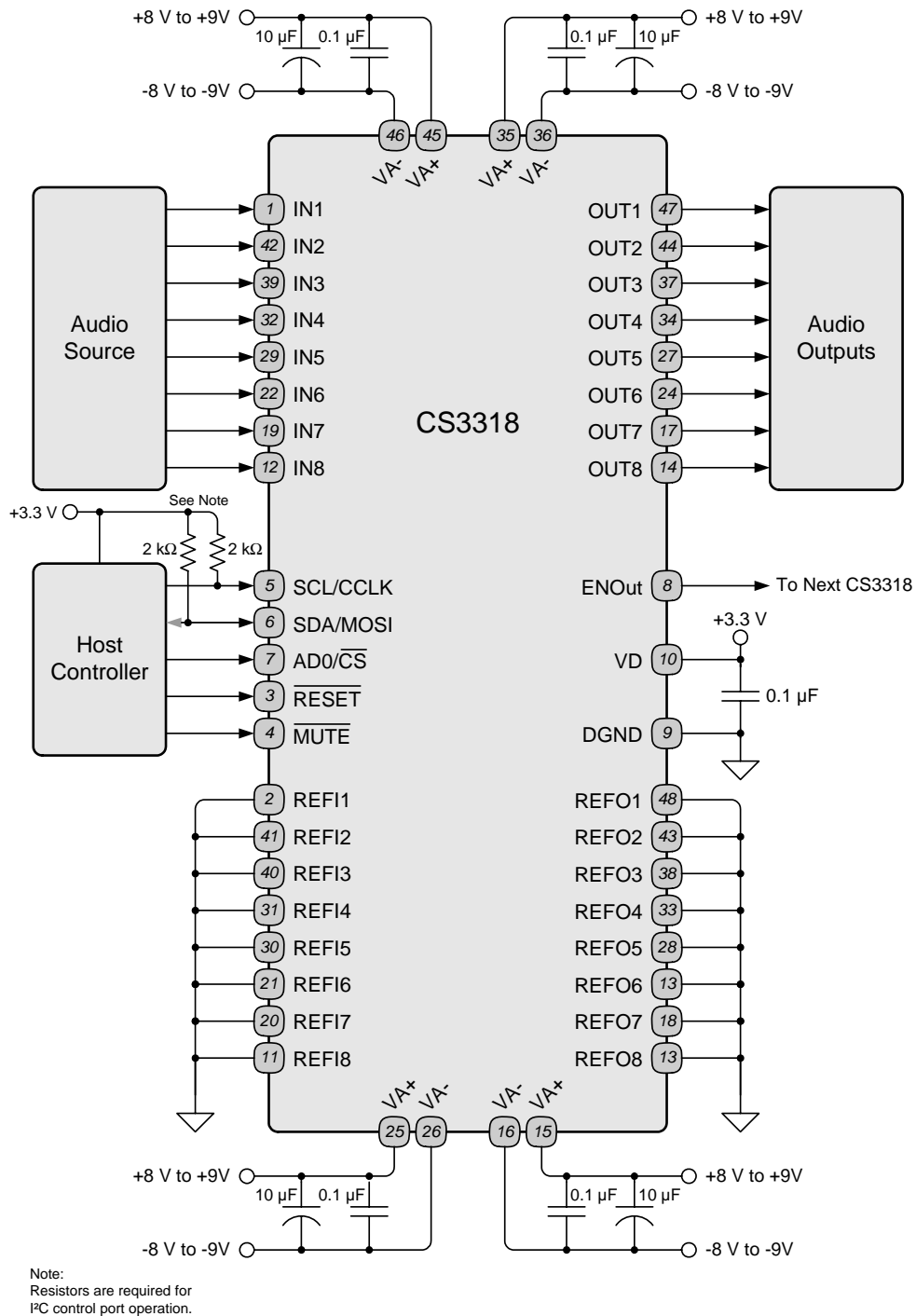
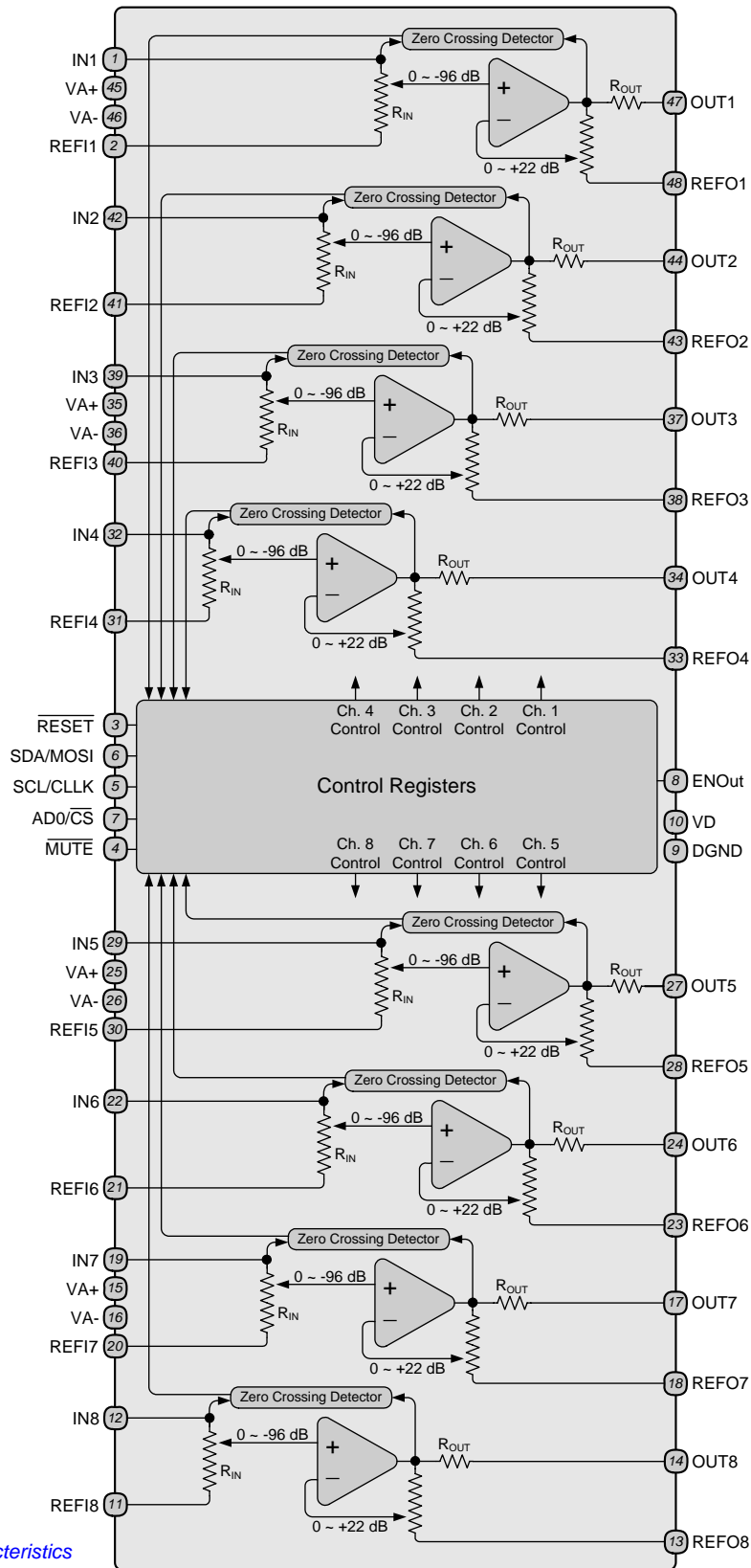

Figure 3. Typical Connection Diagram

4. DETAILED BLOCK DIAGRAM



Refer to the [Analog Characteristics table on page 8](#) for the specified values of R_{IN} and R_{OUT} .

Figure 4. Detailed Block Diagram

5. APPLICATIONS

5.1 General Description

The CS3318 is an 8-channel digitally controlled analog volume control designed for audio systems. It incorporates a total adjustable range of 118 dB in ¼ dB steps, spread evenly over 96 dB of attenuation and 22 dB of gain.

The internal analog architecture includes one op-amp per channel, each with an input resistor network for attenuation and a feedback resistor network for gain. Analog switch arrays are used to select taps in the input and feedback resistor networks, thereby setting the gain or attenuation of each channel. These switch arrays are controlled via the digital control port, bridging the gap between the analog and digital domains. [Figure 4 on page 13](#) provides a detailed diagram of the CS3318's internal architecture.

The CS3318 incorporates highly configurable zero-crossing detection for glitch-free volume level changes. Volume changes may be configured to occur immediately or on a signal zero-crossing. In the event that the signal does not cross zero, the CS3318 provides 8 selectable time-out periods in the range of 5 ms to 50 ms after which the volume level will be changed immediately. When the CS3318 receives more than one volume change command before a zero-crossing or a time-out, the CS3318 is able to implement the previous volume change command immediately or discard it and act only on the most recent command. The [“Zero-Crossing Detection” section on page 22](#) provides a detailed description of the CS3318's zero-crossing detection functionality and controls.

The CS3318 includes a comprehensive I²C/SPI serial control port interface for volume changes and device configuration. This interface provides for easy system integration of up to 128 CS3318 devices over a single 2-wire I²C or 3-wire SPI bus, allowing many channels of volume control with minimal system controller I/O requirements. Devices may be addressed on an individual and grouped basis, simplifying simultaneous configuration of a group of channels across multiple devices, while allowing discrete control over all channels on an individual basis. The [“System Serial Control Configuration” section on page 23](#) provides a detailed description of the serial control port features and functionality.

5.2 System Design

Very few external components are required to support the CS3318. Typical power supply decoupling components are the only external requirements, as shown in [Figure 3 on page 12](#).

5.2.1 Analog Inputs

No external circuitry is required to interface between the audio source and the CS3318's inputs. However, as with any adjustable gain stage, the effects of a DC offset at the input must be considered. Capacitively coupling the analog inputs may be required to prevent “clicks and pops” which occur with gain changes if an appreciable offset is present.

The addition of an input coupling capacitor will form a high-pass filter with the CS3318's input impedance. Given nominal values of input impedance and coupling capacitor, a 10 µF coupling capacitor will result in less than 0.03 dB of attenuation at 20 Hz. If additional low-frequency attenuation can be tolerated, a smaller coupling capacitor may be used.

The CS3318 requires a low source impedance to achieve maximum performance, and a source-impedance of 600 Ω or less is recommended.

The maximum input level is limited by the input signal swing capability of the internal op-amp. Signals approaching the analog supply voltages may be applied to the analog input pins if the internal attenuator limits the output signal to within 1.35 V of the analog supply rails.

5.2.2 Analog Outputs

The analog outputs are capable of driving 2 kΩ loads to within 1.35 V of the analog supply rails and are short-circuit protected to 20 mA.

The minimum output load resistance is 2 kΩ; a load smaller than 2 kΩ may cause increased distortion. As the load resistance decreases, the potential for increased internal heating and the possibility of damage to the device is introduced. Additionally, the load capacitance should be less than 100 pF. Increased load capacitance may cause increased distortion, and the potential for instability in the output amplifiers.

If a low-impedance or high-capacitance load must be driven, an external amplifier should be used to isolate the outputs of the CS3318.

5.2.3 Recommended Layout, Grounding, and Power Supply Decoupling

As with any high-performance device that contains both analog and digital circuitry, careful attention must be provided to power supply and grounding arrangements to optimize performance. Figure 3 on page 12 shows the recommended power arrangements, with VA+, VA-, and VD connected to clean supplies.

Power supply decoupling capacitors should be placed as near to the CS3318 as possible, with the low value ceramic capacitor being the nearest. Care should be taken to ensure that there is minimal resistance in the analog ground leads to the device to prevent any changes in the defined gain/attenuation settings. The use of a unified ground plane is recommended for optimal performance and minimal radiated noise. The CS3318 evaluation board demonstrates the optimum layout and power supply arrangements.

Should the printed circuit board have separate analog and digital regions with independent ground planes, the CS3318 should reside in the analog region of the board.

Extensive use of ground plane fill on the circuit board will yield large reductions in radiated noise effects.

5.3 Power-Up and Power-Down

The CS3318 will remain in a completely powered-down state with the control port inaccessible until the $\overline{\text{RESET}}$ pin is brought high. Once RESET is high, the control port will be accessible, but the internal amplifiers will remain powered-down until the PDN_ALL bit is cleared.

To bring a channel out of power-down, both the PDN_ALL and the channel's PDNx bit must be cleared. By default, all channels' PDNx bits are cleared, and the PDN_ALL bit is set. To minimize audible artifacts during power-up process, the CS3318 automatically holds each channel's volume at mute until its amplifier has completed its power-up sequence. Once the power-up process is complete, each channel's volume will automatically be set to the correct level according to the CS3318's control port settings.

To place a channel in power-down, either the channel's PDNx bit or the PDN_ALL bit must be set. To minimize audible artifacts during the power-down process, the CS3318 automatically places each channel in mute before the amplifier begins its power-down sequence.

The power-up and power-down muting/volume changes are implemented as dictated by the zero-crossing detection settings (see "Zero-Crossing Detection" on page 22). If an immediate power-up or power-down is required, the zero-crossing mode should be set to immediate before changing the power-down state of the device or channel.

Referenced Control	Register Location
PDN_ALL	"Power Down All (Bit 0)" on page 35
PDNx.....	"Channel Power - Address 0Dh" on page 35

5.3.1 Recommended Power-Up Sequence

1. Hold $\overline{\text{RESET}}$ low until the power supplies are stable. In this state, the control port is reset to its default settings.
2. Bring $\overline{\text{RESET}}$ high. The device will remain in a low power state with the PDN_ALL bit set by default. The control port will be accessible.
3. The desired register settings can be loaded while the PDN_ALL bit remains set.
4. Clear the PDN_ALL bit to initiate the power-up sequence.

5.3.2 Recommended Power-Down Sequence

1. Set the PDN_ALL bit to mute all channels and power-down all internal amplifiers.
2. If desired, hold $\overline{\text{RESET}}$ low to bring the CS3318's power consumption to an absolute minimum.

5.4 Volume & Muting Control Architecture

The CS3318's volume and muting control architecture provides the ability to control each channel on an individual and master basis.

Individual control allows the volume and mute state of a single channel to be changed independently from all other channels within the device. The CS3318 provides 8 individual volume and muting controls, each permanently assigned to one channel within the device.

Master control allows the volume and mute state of multiple channels to be changed simultaneously with a single register write. The CS3318 provides three master controls, and each may be configured to affect any group of channels within a device.

Refer to the [“Volume Controls” section beginning on page 19](#) and the [“Muting Controls” section beginning on page 21](#) for an in-depth description of the operation of the available controls.

5.4.1 Control Mapping Matrix

[Figure 5](#) shows a conceptual drawing of the CS3318's internal control-to-channel mapping matrix. Notice that the individual channel controls are fixed to their respective channel, and the master controls may be configured to affect any or all channels within the device.

Each master control has a corresponding Master X Mask register which allows the user to select which channels are affected by the control. By default, each master control is configured to affect all channels within the device. Referring to [Figure 5](#) below, each configurable connection shown may be made and broken by setting or clearing its corresponding bit in the control's Master X Mask register.

The contents of the Master X Mask registers determine which channels are affected by both a master control's volume and mute settings. Refer to the [“Volume & Muting Control Implementation” section on page 18](#) for a complete diagram of the CS3318's volume and muting control architecture.

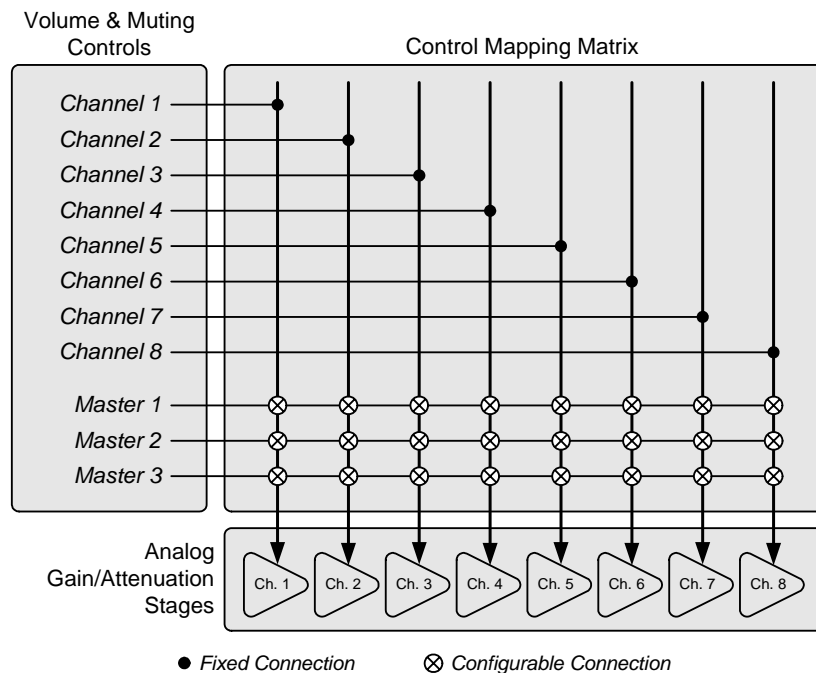

Figure 5. CS3318 Control Mapping Matrix

Combining the multiple group addressing capabilities of the CS3318 (as detailed in [section 5.8.2 on page 24](#)) with the internal master logical control mapping abilities described above allows the configuration and direct addressing of multiple logical groups of channels across multiple CS3318 devices within a system.

Referenced Control	Register Location
Master X Mask	"Master 1 Mask - Address 10h" on page 36 "Master 2 Mask - Address 13h" on page 37 "Master 3 Mask - Address 16h" on page 38

5.4.2 Volume & Muting Control Implementation

[Figure 6](#) below diagrams in detail the volume and muting control architecture of the CS3318 for an arbitrary channel 'N'.

This diagram incorporates all volume and muting control concepts presented in sections 5.4 - 5.6; it is included as a reference and will serve to corroborate the information presented in these sections.

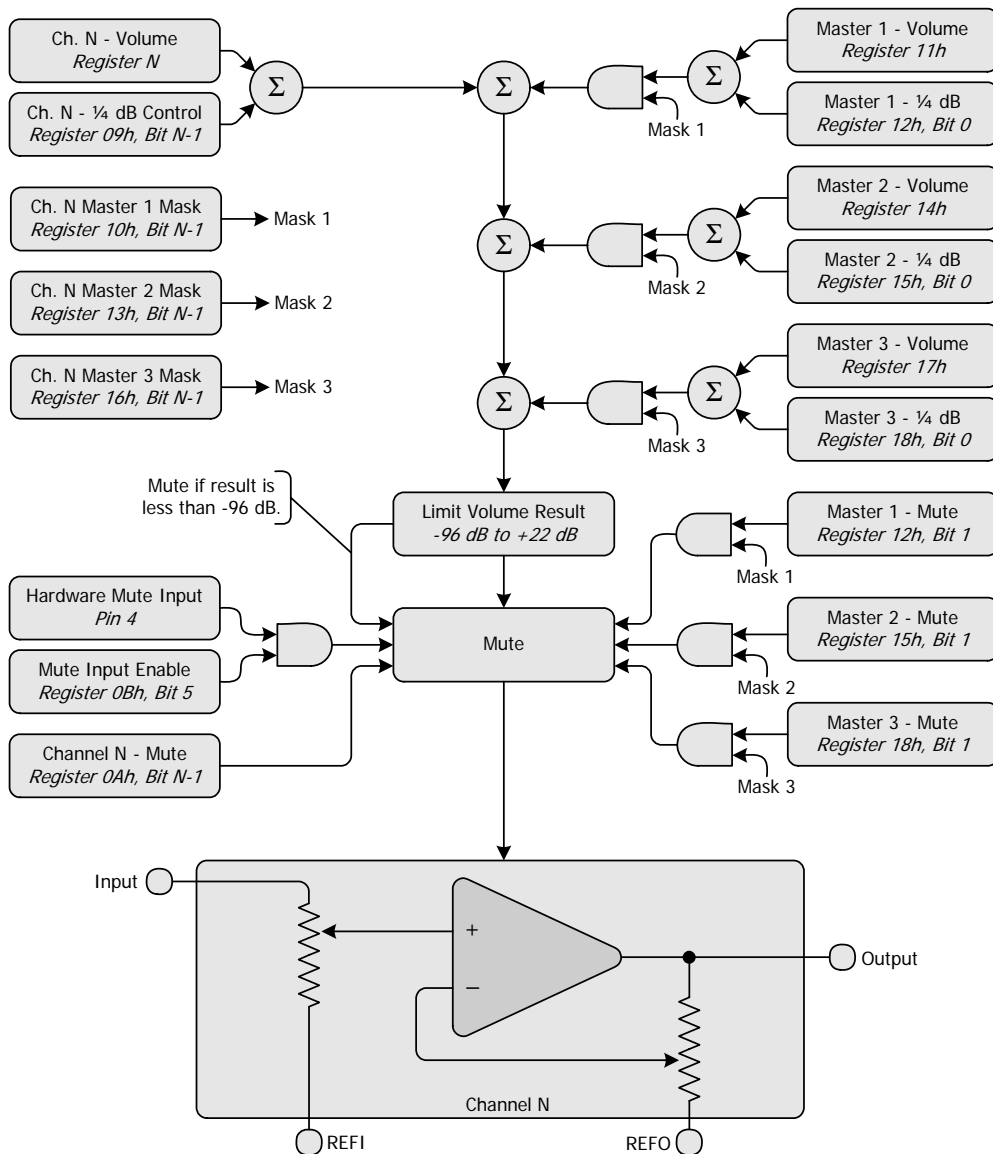

Figure 6. Volume & Muting Control Implementation

5.5 Volume Controls

The CS3318 provides comprehensive volume control functionality, allowing each channel's volume to be changed on an individual or master basis. Refer to the [“Volume & Muting Control Architecture” section on page 17](#) for complete details about the configuration of the CS3318's individual and master controls.

The CS3318 incorporates zero-crossing detection capabilities, and all volume changes are implemented as dictated by the zero-crossing detection settings (see [“Zero-Crossing Detection” on page 22](#)).

5.5.1 Individual Channel Volume Controls

The CS3318 provides 8 individual channel volume controls. These controls can be used to independently gain and/or attenuate each of the input/output channels over a range of +22 dB to -96 dB in ¼ dB steps.

Each channel has a corresponding Ch. X Volume register used to gain or attenuate the channel from +22 dB to -96 dB in ½ dB steps. The ¼ dB Control register contains one bit per channel used to add an additional ¼ dB gain to the channel's volume as set by its Ch. X Volume register.

Referenced Control	Register Location
Ch. X Volume	“Ch 1-8 Volume - Addresses 01h - 08h” on page 31
¼ dB Control	“¼ dB Control - Address 09h” on page 32

5.5.2 Master Volume Controls

The CS3318 master volume controls allow the user to simultaneously gain or attenuate a user defined set of channels from +22 dB to -96 dB in ¼ dB increments. A total of 3 master volume controls, Master 1, Master 2, and Master 3, are provided for comprehensive and flexible control.

Each master volume control has a corresponding Master X Volume register which is used to gain or attenuate the control's respective unmasked channels from +22 dB to -96 dB in ½ dB steps. The LSB of the corresponding Master X Control register contains one bit used to add an additional ¼ dB gain to the master volume control's value as set by its Master X Volume register.

As discussed in the [“Volume & Muting Control Architecture” section on page 17](#), each master volume control has a corresponding Master X Mask register which allows the user to select which channels are affected by the control. By default, each master control is configured to affect all channels within the device.

The *effective volume* setting of an individual channel is determined by the following equation:

$$EffVol_{ChN} = Individual_{ChN} + (Master\ 1\ \&\ Mask\ 1_{ChN}) + (Master\ 2\ \&\ Mask\ 2_{ChN}) + (Master\ 3\ \&\ Mask\ 3_{ChN})$$

Equation 1. Effective Volume Setting

In this equation, $EffVol_{ChN}$ represents the actual gain or attenuation level, in dB, of the individual channel “N” as determined by the its constituent volume settings within the CS3318. The effective volume is limited to the range of +22 dB to -96 dB; see [“Volume Limits” on page 20](#).

$Individual_{ChN}$ is the individual channel volume setting in dB as set by the channel's individual volume control register and ¼ dB bit (see [“Individual Channel Volume Controls” on page 19](#)).

$Master\ X$ is the Master X volume setting in dB as set by the master volume control registers and their respective ¼ dB bits.

$Mask\ X_{ChN}$ is the channel N mask bit associated with the Master X volume control setting.

This volume control architecture in combination with the multiple group addressing capabilities of the CS3318 (as detailed in [section 5.8.2 on page 24](#)) allows easy volume control of multiple channels across multiple devices in a system while eliminating the system controller overhead typically associated digitally driven analog volume control devices.

Table 1 shows example volume settings using individual and master volume controls.

	Individual _{ChX}	Master 1	Mask 1 _{ChX}	Master 2	Mask 2 _{ChX}	Master 3	Mask 3 _{ChX}	Level _{ChX}
Channel 1	+3.75 dB	+1.0 dB	0	+5.25 dB	0	-8.5 dB	0	+3.75 dB
Channel 2	+2.5 dB		0		0		-6.0 dB	
Channel 3	+1.25 dB		0		1		+6.5 dB	
Channel 4	0 dB		0		1		-3.25 dB	
Channel 5	-1.25 dB		1		0		-0.25 dB	
Channel 6	-2.5 dB		1		0		-10.0 dB	
Channel 7	-3.75 dB		1		1		+2.5 dB	
Channel 8	-4.0 dB		1		1		-6.25 dB	

Table 1. Example Volume Settings

Refer to [Figure 6 on page 18](#) for a graphical representation of the volume controls' functionality.

Referenced Control	Register Location
Master X Volume.....	"Master 1 Volume - Address 11h" on page 36 "Master 2 Volume - Address 14h" on page 37 "Master 3 Volume - Address 17h" on page 38
Master X Control.....	"Master 1 Control - Address 12h" on page 37 "Master 2 Control - Address 15h" on page 38 "Master 3 Control - Address 18h" on page 39
Master X Mask.....	"Master 1 Mask - Address 10h" on page 36 "Master 2 Mask - Address 13h" on page 37 "Master 3 Mask - Address 16h" on page 38

5.5.3 Volume Limits

The analog section of the CS3318 is designed to accommodate gain and attenuation over the range of +22 dB to -96 dB. Values outside this range may, however, be written to the CS3318's internal registers. As shown in [Figure 6 on page 18](#), the value of the Individual and Master volume control registers are summed before being limited to the range allowed by the CS3318's analog section. This architecture has the benefit of allowing both individual and master volume control input beyond the analog range of the CS3318.

If the effective volume (See [Equation 1 on page 19](#)) of an individual channel is greater than +22 dB, the channel's volume will be set to +22 dB.

If the effective volume of an individual channel is less than -96 dB, the channel will mute, but the MuteChX bit will not be set. When the channel's effective volume returns to -96 dB or above, the mute condition will be released. It should be noted that if the channel's MuteChX bit or any of the channel's unmasked Master X Mute bits are set, the channel will remain muted until the necessary mute conditions are released.

Referenced Control	Register Location
MuteChX.....	"Mute Control - Address 0Ah" on page 33
Master X Mute.....	"Master 1 Mute (Bit 1)" on page 37 "Master 2 Mute (Bit 1)" on page 38 "Master 3 Mute (Bit 1)" on page 39

5.6 Muting Controls

The CS3318 provides flexible muting capabilities to complement its comprehensive volume control abilities. Each channel's mute state may be controlled on an individual channel basis, by any of 3 master mute controls, and by the hardware $\overline{\text{MUTE}}$ input pin.

The mute state of any channel within the CS3318 is determined by the logical OR of four conditions, and the channel will mute if any one or more of the conditions are met. These conditions are:

1. The channel's individual mute condition is set.
2. One or more of the channel's unmasked master mute conditions are set.
3. The hardware mute input is enabled and active.
4. The channel's effective volume (See [Equation 1 on page 19](#)) is less than -96 dB.

The CS3318 incorporates zero-crossing detection capabilities, and all muting changes are implemented as dictated by the zero-crossing detection settings (see ["Zero-Crossing Detection" on page 22](#)).

5.6.1 Individual Channel Mute Controls

The CS3318 provides 8 individual channel mute controls. These controls can be used to individually mute each of the input/output channels independent of all other volume and mute settings.

Individual channel mute control is accomplished by setting or clearing the channel's corresponding MuteChX bit in the Mute Control register.

Referenced Control	Register Location
MuteChX	"Mute Control - Address 0Ah" on page 33

5.6.2 Master Mute Controls

The CS3318 master mute controls allow the user to simultaneously control the mute state of all channels, or a user-defined subset of all channels within a device. A total of 3 master mute controls, M1_Mute, M2_Mute, and M3_Mute, are provided for comprehensive and flexible control.

Master mute control is accomplished by setting or clearing the MX_Mute bit in the corresponding Master Control register. Each master mute control affects only those channels unmasked in its corresponding Master X Mask register.

Referenced Control	Register Location
MX_Mute	"Master 1 Mute (Bit 1)" on page 37 "Master 2 Mute (Bit 1)" on page 38 "Master 3 Mute (Bit 1)" on page 39
Master X Mask	"Master 1 Mask - Address 10h" on page 36 "Master 2 Mask - Address 13h" on page 37 "Master 3 Mask - Address 16h" on page 38

5.6.3 Hardware Mute Control

The CS3318 implements a hardware $\overline{\text{MUTE}}$ input pin to allow the user to control the mute state of all channels with an external level-active signal. By default, the $\overline{\text{MUTE}}$ input is configured for active low operation, and all channels will be held in a mute state whenever this input is low.

For enhanced flexibility, setting the MutePolarity bit will configure the $\overline{\text{MUTE}}$ input pin for active high operation. Additionally, the EnMuteIn bit may be cleared to disable the CS3318's response to the $\overline{\text{MUTE}}$ input signal.

Referenced Control	Register Location
MutePolarity	"MUTE Input Polarity (Bit 4)" on page 33
EnMuteIn	"Enable MUTE Input (Bit 5)" on page 33

5.7 Zero-Crossing Detection

The CS3318 incorporates comprehensive zero-crossing detection features to provide for noise-free level transitions. Three zero-crossing detection modes and 8 selectable time-out periods are available for enhanced flexibility. Zero-crossing detection and time-out is implemented independently for each channel.

5.7.1 Zero-Crossing Modes

The zero-crossing mode for all channels within the CS3318 are configured via the ZCMode[1:0] bits in the Device Config 2 register. By default, zero-crossing mode 1 is selected. The zero-crossing modes are detailed in [Table 2](#).

Mode	Zero-Crossing Function
0	Volume changes take effect immediately.
1	Volume changes take effect on a signal zero-crossing. If a zero-crossing is not detected before the time-out period has elapsed, the volume change will be implemented immediately when the time-out period elapses. If the volume setting is changed again before the original volume change has been implemented, the original change will be discarded, the time-out period will be reset, and the new volume setting will take effect when a zero-crossing is detected or the time-out period elapses.
2	Volume changes take effect on a signal zero-crossing. If a zero-crossing is not detected before the time-out period has elapsed, the volume change will be implemented immediately when the time-out period elapses. If the volume setting is changed again before the original volume change has been implemented, the original volume change will be implemented immediately upon reception of the new volume change command, the time-out period will be reset, and the new volume setting will take effect when a zero-crossing is detected or the time-out period elapses.

Table 2. Zero-Crossing Modes

Referenced Control	Register Location
ZCMode[1:0]	“Zero-Crossing Mode (Bits 1:0)” on page 35

5.7.2 Zero-Crossing Time-Out

When in zero-crossing mode 1 or 2, the zero-crossing time-out period dictates how long the CS3318 will wait for a signal zero-crossing before implementing the requested volume change without a zero-crossing, thereby allowing the possibility of audible artifacts. The CS3318 provides 8 selectable time-out periods ranging from 5 ms to 50 ms; these are shown in [Table 3](#).

Time-Out Setting	Time-Out Period
0	5 ms
1	10 ms
2	15 ms
3	18 ms
4	20 ms
5	30 ms
6	40 ms
7	50 ms

Table 3. Zero-Crossing Time-Out Periods

The zero-crossing time-out period for all channels within the CS3318 is configured via the TimeOut[2:0] bits in the Device Config 2 register. The time-out period is set to 18 ms (setting 3) by default.

Referenced Control	Register Location
TimeOut[2:0]	“Zero-Crossing Time-Out Period (Bits 4:2)” on page 34

5.8 System Serial Control Configuration

The CS3318 includes a comprehensive serial control port which supports both SPI and I²C modes of communication (See the “[I²C/SPI Serial Control Formats](#)” section on page 27). The control port uses the shared serial control bus to define each device’s slave address. This allows independent control of up to 128 devices on the shared serial control bus without requiring hardware device address configuration pins or any more than one \overline{CS} signal (for SPI mode).

Each device will respond to three different chip addresses; Individual, Group 1, and Group 2. The device’s Individual chip address provides read and write access to the CS3318’s internal registers. The device’s Group 1 and Group 2 addresses provide write-only access to the CS3318’s internal registers. If a read operation is requested using either the Group 1 or Group 2 address, the devices will not respond to the request. Upon the release of \overline{RESET} , each of these device addresses initializes to the default address. In this state, the device will respond to both register reads and writes when addressed with this default address.

Each of the device’s addresses may be changed via a standard serial register write to an internal register of the CS3318. Using this method, each device may be assigned a unique Individual address, and groups of devices may be assigned shared Group 1 and Group 2 addresses for simultaneous control. Use of the master volume and mute controls in combination with the available group addresses provides for easy master and sub-master control within a multiple CS3318 system.

Referenced Control	Register Location
Individual Address	“Individual Chip Address 1Bh” on page 41
Group 1 Address	“Group 1 Chip Address 1Ah” on page 40
Group 2 Address	“Group 2 Chip Address 19h” on page 40

5.8.1 Serial Control within a Single-CS3318 System

In a single CS3318 system, no special attention must be given to the serial control port operation of the CS3318. The standard serial control signals (SDA and SCL for I²C Mode, or MOSI, CCLK, and \overline{CS} for SPI Mode) should be connected to the system controller, and the ENOut signal is not used (see [Figures 7 and 8](#)). Upon the release of \overline{RESET} , the CS3318 must be addressed with its default chip address.

Although it is not necessary, the default Individual, Group 1, and Group 2 chip addresses may be changed by writing their respective control port registers. Once the contents of these registers has been modified, the device must be addressed with the registers’ new contents. When the device is reset, its device addresses will return to their default value.

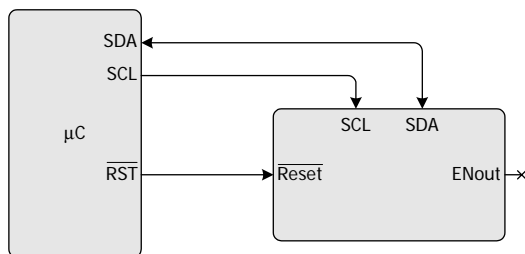

Figure 7. Standard I²C Connections

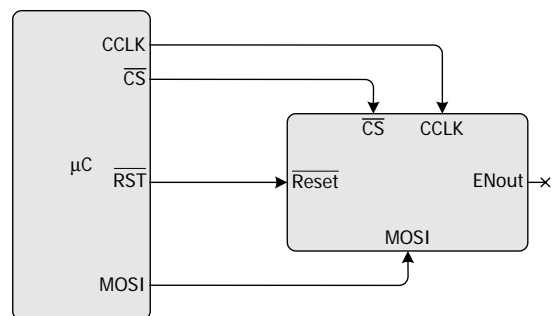

Figure 8. Standard SPI Connections

5.8.2 Serial Control within a Multiple-CS3318 System

The CS3318 allows both independent and simultaneous control of up to 128 devices on a shared I²C or SPI serial control bus. The address of each device is configured by the host controller via the shared serial control bus. All serial communication, including the configuration of each device's address, adheres to a standard I²C or SPI bus protocol.

A device's Individual device address, which provides read and write access to the device's internal registers, should be set to a unique value, different from all other addresses recognized by devices on the serial communication bus. This address facilitates independent control of each CS3318 on the serial control bus.

A device's Group 1 and Group 2 addresses, which provide write-only access to the device's internal registers, may be set to the same value across multiple CS3318's on the shared serial communication bus. Assigning common Group addresses to multiple devices in a system allows system sub-master and system master volume control. For instance, a system containing 8 CS3318's may configure the Group 1 address of the first set of 4 CS3318's to 10h, the Group 1 address of the second set of 4 CS3318's to 20h, and the Group 2 address of all 8 CS3318's to A0h. In this manner, a serial control data write to address 10h would act as a system sub-master control to the first set of 4 devices, a write to 20h would act as a system sub-master control to the second set of 4 devices, and a write to A0h would act as a system master control to all devices.

By default, the CS3318 will not respond to serial communication when addressed with its Group 1 or Group 2 address. The CS3318 will only respond to one or both of these addresses if the corresponding address has been enabled via the control port. To enable a Group address, its corresponding Enable bit, located in the LSB of its respective Group address register, must be set.

The CS3318 implements an ENOut signal to facilitate the device address configuration process. This signal is used to hold all but one un-configured device in a reset state. After the Individual device address of each device has been set, the ENOut signal is used to enable the "next" device in the chain, allowing its Individual device address to be set. See "[SPI Mode Serial Control Configuration](#)" section on page 24 and "[I²C Mode Control Configuration](#)" on page 26 for more information about system configuration in each communication mode.

5.8.2.1 SPI Mode Serial Control Configuration

Up to 128 CS3318's sharing the same \overline{CS} signal may be connected to a common SPI serial control bus. This shared serial bus is used to assign a unique device address to each device on the bus such that they may be independently addressed. To implement this method of device address configuration, the devices must be connected as shown in [Figure 9](#).

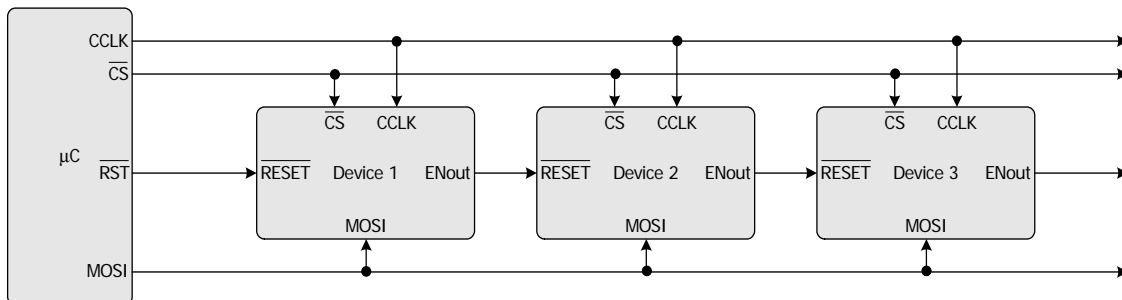

Figure 9. SPI Serial Control Connections

Note that the serial control signals CCLK, CS, and MOSI are connected in parallel to each CS3318. The active low reset output of the system controller is connected to the \overline{RESET} input of the first CS3318 in the chain. The ENOut of the first device is connected to the \overline{RESET} input of the second CS3318 whose ENOut signal is connected to the third CS3318. This pattern of connecting the ENOut of device N to the \overline{RESET}

input of device N+1 may be repeated for up to 128 devices per single \overline{CS} signal. If more than 128 devices are required in a system, separate \overline{CS} signals may be used to create additional chains of up to 128 devices per \overline{CS} signal.

As each device is placed into reset (\overline{RESET} is low), its ENOut signal is driven low. The ENOut signal will continue to be driven low until the device is taken out of reset (\overline{RESET} is high) and the Enable bit (see “[Enable Next Device \(Bit 0\)](#)” on page 41) is set, at which time the ENOut signal will be driven high.

To configure a unique Individual device address for each device on the shared serial bus, the first device must be reset (a low to high transition on its \overline{RESET} pin), the Individual device address register must be written (using the CS3318’s default device address) with a unique device address, and the Enable bit must be set to take the next device in the serial control chain out of reset. This process may be repeated until all devices in the serial control chain have been assigned a new Individual device address. [Figure 10](#) diagrams this configuration process.

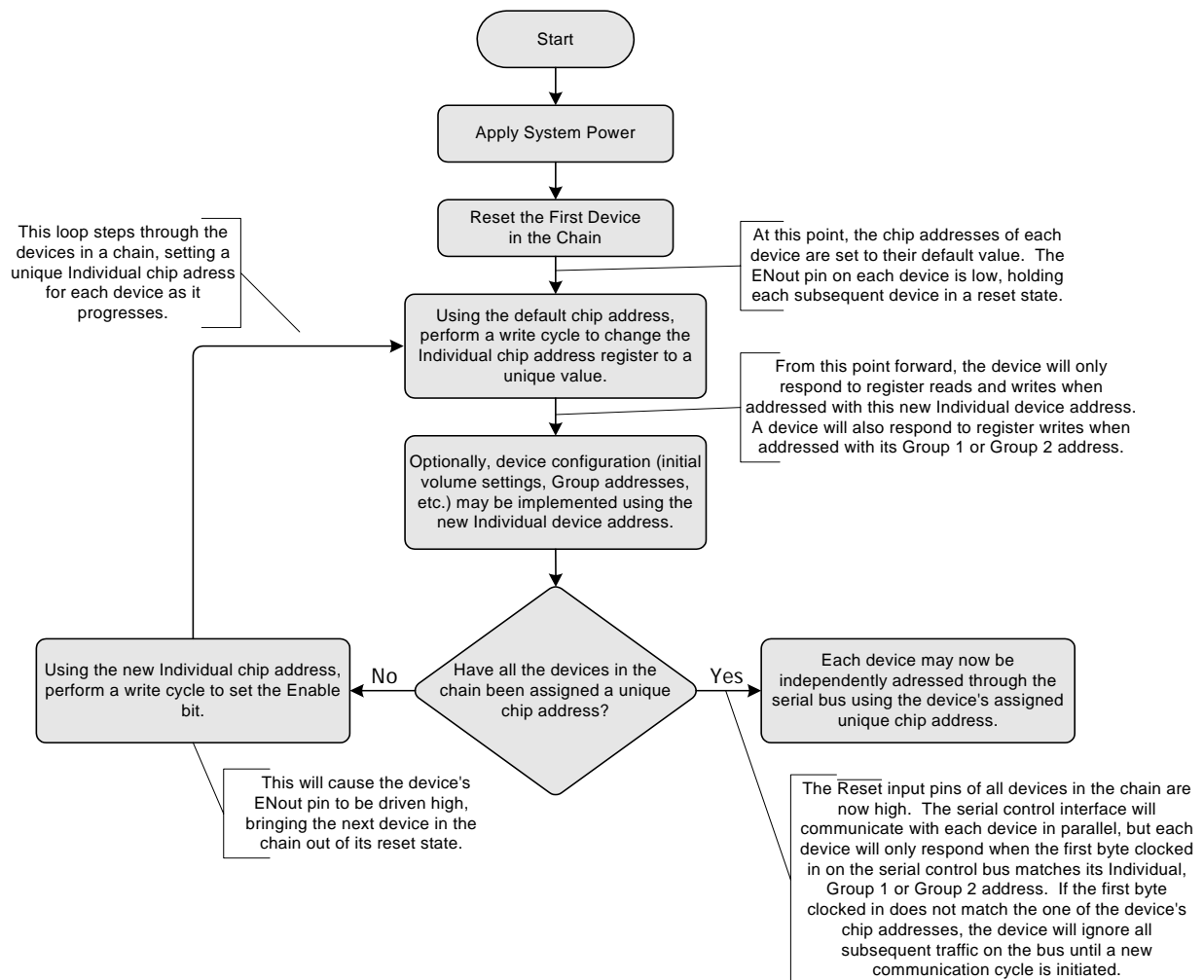

Figure 10. Individual Device Address Configuration Process

Notice that [Figure 10](#) shows the setting of the Individual address and the setting of the Enable bit as two discrete steps. While this demonstrates one approach to device configuration, it should be noted that two steps are not necessary to complete the action of setting the Individual address and enabling the next device. This may be done simultaneously with one register write (containing the new Individual address and the Enable bit set) to the Individual address register.

Once this configuration process is complete, every device may be independently controlled with a standard SPI communication cycle using the device's newly assigned Individual device addresses.

5.8.2.2 I²C Mode Control Configuration

Up to 128 CS3318's may be connected to a common I²C serial control bus. This shared serial bus is used to assign a unique device address to each device on the bus such that they may be independently addressed. To implement this method of device address configuration, the devices must be connected as shown in Figure 11.

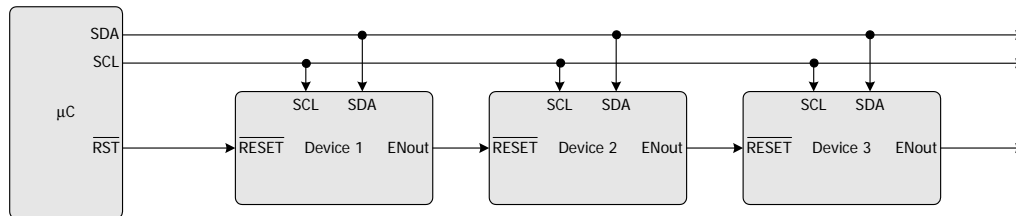

Figure 11. I²C Serial Control Connections

Note that the serial control signals SCL and SDA are connected in parallel to each CS3318. The active low reset output of the system controller is connected to the RESET input of the first CS3318 in the chain. The ENOut of the first device is connected to the RESET input of the second CS3318 whose ENOut signal is connected to the third CS3318. This pattern of connecting the ENOut of device N to the RESET input of device N+1 may be repeated for up to 128 devices per common I²C bus. If more than 128 devices are required in a system, separate SDA or SCL signals may be used to create additional chains of up to 128 devices.

As each device is placed into reset ($\overline{\text{RESET}}$ is low), its ENOut signal is driven low. The ENOut signal will continue to be driven low until the device is taken out of reset ($\overline{\text{RESET}}$ is high) and the Enable bit (see “[Enable Next Device \(Bit 0\)](#)” on page 41) is set, at which time the ENOut signal will be driven high.

To configure a unique Individual device address for each device on the shared serial bus, the first device must be reset (a low to high transition on its $\overline{\text{RESET}}$ pin), the Individual device address register must be written (using the CS3318's default device address) with a unique device address, and the Enable bit must be set to take the next device in the serial control chain out of reset. This process may be repeated until all devices in the serial control chain have been assigned a new Individual device address. Figure 10 diagrams this configuration process.

Notice that Figure 10 shows the setting of the Individual address and the setting of the Enable bit as two discrete steps. While this demonstrates one approach to device configuration, it should be noted that two steps are not necessary to complete the action of setting the Individual address and enabling the next device. This may be done simultaneously with one register write (containing the new Individual address and the Enable bit set) to the Individual address register.

Once the configuration process is complete, every device may be independently controlled with a standard I²C communication cycle using the device's newly assigned Individual device addresses.

5.9 I²C/SPI Serial Control Formats

The control port is used to access the internal registers of the CS3318. The control port has 2 modes: SPI and I²C, with the CS3318 acting as a slave device. SPI Mode is selected if there is a high-to-low transition on the \overline{CS} pin after the \overline{RESET} pin has been brought high. I²C Mode is selected by connecting the \overline{CS} pin to VD or DGND.

5.9.1 I²C Mode

In I²C Mode, SDA is a bidirectional data line. Data is clocked into and out of the CS3318 by the clock, SCL. The AD0 pin sets the least significant bit of the default chip address and must be connected to VD or DGND. The AD0 pin is read upon the release of the \overline{RESET} signal (a low-to-high transition), and its value ('0' when connected to DGND, '1' when connected to VD) is reflected in the LSB of the chip address in the Individual, Group 1, and Group 2 Chip Address registers. Table 4 shows the default chip addresses in I²C Mode.

AD0 Connection	Default Chip Address
DGND	1000000b
VD	1000001b

Table 4. I²C Mode Default Chip Address

The signal timings for a read and write cycle are shown in Figure 12 and Figure 13. A Start condition is defined as a falling transition of SDA while the clock is high. A Stop condition is a rising transition while the clock is high. All other transitions of SDA occur while the clock is low.

The first byte sent to the CS3318 after a Start condition consists of a 7-bit chip address field and a R/W bit (high for a read, low for a write). To communicate with a CS3318, the chip address field should match either the Individual, Group 1, or Group 2 device address as set by their respective control port registers. The eighth bit of the address is the R/W bit. If the read/write bit is set high (indicating a read operation) and the preceding 7 bits do not match its Individual address, the CS3318 will ignore all traffic on the I²C bus until a Stop and Start condition occurs.

If the operation is a write, the next byte is the Memory Address Pointer (MAP) which selects the register to be read or written. If the operation is a read, the contents of the register pointed to by the MAP will be output.

There is a MAP auto-increment capability, enabled by the INCR bit (the MSB of the MAP byte). If INCR is '0', the MAP will stay constant for successive read or writes. If INCR is '1', the MAP will automatically increment after each byte is written, allowing block writes of successive registers. Each byte is separated by an acknowledge (ACK) bit. The ACK bit is output from the CS3318 after each input byte is read and is input to the CS3318 from the microcontroller after each transmitted byte.

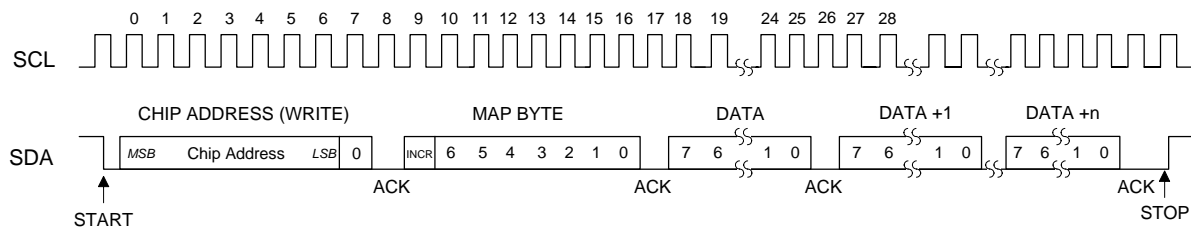

Figure 12. Control Port Timing, I²C Write

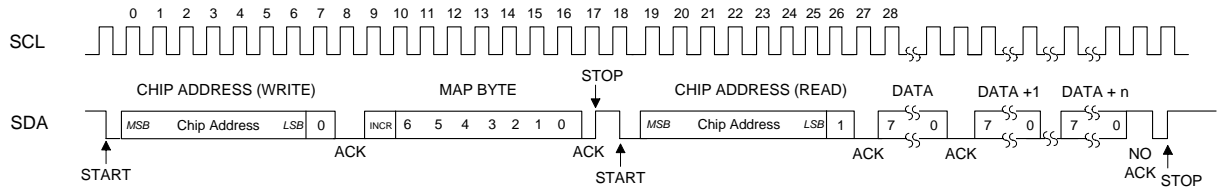

Figure 13. Control Port Timing, I²C Read

Since the read operation cannot set the MAP, an aborted write operation is used as a preamble. As shown in Figure 13, the write operation is aborted after the acknowledge for the MAP byte by sending a stop condition.

Referenced Control	Register Location
Individual Address.....	"Individual Chip Address 1Bh" on page 41
Group 1 Address.....	"Group 1 Chip Address 1Ah" on page 40
Group 2 Address.....	"Group 2 Chip Address 19h" on page 40

5.9.2 SPI Mode

In SPI Mode, \overline{CS} is the CS3318 chip-select signal, CCLK, is the control port bit clock (input into the CS3318 from the microcontroller), and MOSI is the input data line from the microcontroller. Data is clocked in on the rising edge of CCLK. The default chip address in SPI Mode is 1000000b.

Figure 14 shows the operation of the control port in SPI Mode. To write to a register, bring \overline{CS} low. The first seven bits on MOSI form the chip address and must be either the Individual, Group 1, or Group 2 chip address as set by their respective control port registers. The eighth bit is a read/write indicator (R/W), which must be low to write. If the read/write indicator is set high (indicating a read operation), the CS3318 will ignore all traffic on the SPI bus until \overline{CS} is brought high and then low again. The next eight bits form the Memory Address Pointer (MAP), which is set to the address of the register that is to be written. The next eight bits are the data which will be placed into the register designated by the MAP.

There is a MAP auto increment capability, enabled by the INCR bit (the MSB of the MAP byte). If INCR is '0', the MAP will stay constant for successive read or writes. If INCR is '1', the MAP will automatically increment after each byte is written, allowing block writes of successive registers.

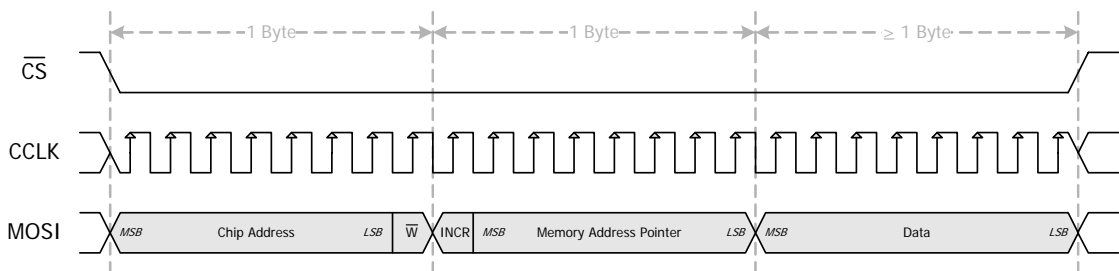

Figure 14. SPI Write Cycle

Referenced Control	Register Location
Individual Address.....	"Individual Chip Address 1Bh" on page 41
Group 1 Address.....	"Group 1 Chip Address 1Ah" on page 40
Group 2 Address.....	"Group 2 Chip Address 19h" on page 40

6. CS3318 REGISTER QUICK REFERENCE

This table shows the register names and their associated default values.

Addr	Function	7	6	5	4	3	2	1	0
01h	Ch. 1 Volume	Vol7	Vol6	Vol5	Vol4	Vol3	Vol2	Vol1	Vol0
	page 31	1	1	0	1	0	0	1	0
02h	Ch. 2 Volume	Vol7	Vol6	Vol5	Vol4	Vol3	Vol2	Vol1	Vol0
	page 31	1	1	0	1	0	0	1	0
03h	Ch. 3 Volume	Vol7	Vol6	Vol5	Vol4	Vol3	Vol2	Vol1	Vol0
	page 31	1	1	0	1	0	0	1	0
04h	Ch. 4 Volume	Vol7	Vol6	Vol5	Vol4	Vol3	Vol2	Vol1	Vol0
	page 31	1	1	0	1	0	0	1	0
05h	Ch. 5 Volume	Vol7	Vol6	Vol5	Vol4	Vol3	Vol2	Vol1	Vol0
	page 31	1	1	0	1	0	0	1	0
06h	Ch. 6 Volume	Vol7	Vol6	Vol5	Vol4	Vol3	Vol2	Vol1	Vol0
	page 31	1	1	0	1	0	0	1	0
07h	Ch. 7 Volume	Vol7	Vol6	Vol5	Vol4	Vol3	Vol2	Vol1	Vol0
	page 31	1	1	0	1	0	0	1	0
08h	Ch. 8 Volume	Vol7	Vol6	Vol5	Vol4	Vol3	Vol2	Vol1	Vol0
	page 31	1	1	0	1	0	0	1	0
09h	¼ dB Control	Quarter8	Quarter7	Quarter6	Quarter5	Quarter4	Quarter3	Quarter2	Quarter1
	page 32	0	0	0	0	0	0	0	0
0Ah	Mute Control	MuteCh8	MuteCh7	MuteCh6	MuteCh5	MuteCh4	MuteCh3	MuteCh2	MuteCh1
	page 33	0	0	0	0	0	0	0	0
0Bh	Device Config 1	Reserved	Reserved	EnMutIn	MutePolarity	Ch8=7	Ch6=5	Ch4=3	Ch2=1
	page 33	0	0	1	0	0	0	0	0
0Ch	Device Config 2	Reserved	Reserved	Reserved	TimeOut2	TimeOut1	TimeOut0	ZCMode1	ZCMode0
	page 34	0	0	0	0	1	1	0	1
0Dh	Channel Power	PDN8	PDN7	PDN6	PDN5	PDN4	PDN3	PDN2	PDN1
	page 35	0	0	0	0	0	0	0	0
0Eh	Master Power	Reserved	Reserved	Reserved	Reserved	Reserved	Reserved	Reserved	PDN_ALL
	page 35	0	0	0	0	0	0	0	1
0Fh	Freeze Control	Reserved	Reserved	Reserved	Reserved	Reserved	Reserved	Reserved	Freeze
	page 36	0	0	0	0	0	0	0	0

Addr	Function	7	6	5	4	3	2	1	0
10h	Master 1 Mask page 36	M1_Ch8M	M1_Ch7M	M1_Ch6M	M1_Ch5M	M1_Ch4M	M1_Ch3M	M1_Ch2M	M1_Ch1M
		1	1	1	1	1	1	1	1
11h	Master 1 Volume page 36	M1_Vol7	M1_Vol6	M1_Vol5	M1_Vol4	M1_Vol3	M1_Vol2	M1_Vol1	M1_Vol0
		1	1	0	1	0	0	1	0
12h	Master 1 Control page 37	Reserved	Reserved	Reserved	Reserved	Reserved	Reserved	M1_Mute	M1_Qtr
		0	0	0	0	0	0	0	0
13h	Master 2 Mask page 37	M2_Ch8M	M2_Ch7M	M2_Ch6M	M2_Ch5M	M2_Ch4M	M2_Ch3M	M2_Ch2M	M2_Ch1M
		1	1	1	1	1	1	1	1
14h	Master 2 Volume page 37	M2_Vol7	M2_Vol6	M2_Vol5	M2_Vol4	M2_Vol3	M2_Vol2	M2_Vol1	M2_Vol0
		1	1	0	1	0	0	1	0
15h	Master 2 Control page 38	Reserved	Reserved	Reserved	Reserved	Reserved	Reserved	M2_Mute	M2_Qtr
		0	0	0	0	0	0	0	0
16h	Master 3 Mask page 38	M3_Ch8M	M3_Ch7M	M3_Ch6M	M3_Ch5M	M3_Ch4M	M3_Ch3M	M3_Ch2M	M3_Ch1M
		1	1	1	1	1	1	1	1
17h	Master 3 Volume page 38	M3_Vol7	M3_Vol6	M3_Vol5	M3_Vol4	M3_Vol3	M3_Vol2	M3_Vol1	M3_Vol0
		1	1	0	1	0	0	1	0
18h	Master 3 Control page 39	Reserved	Reserved	Reserved	Reserved	Reserved	Reserved	M3_Mute	M3_Qtr
		0	0	0	0	0	0	0	0
19h	Group 2 Chip Addr page 40	G2_Addr6	G2_Addr5	G2_Addr4	G2_Addr3	G2_Addr2	G2_Addr1	G2_Addr0	EnG2Addr
		1	0	0	0	0	0	X	0
1Ah	Group 1 Chip Addr page 40	G1_Addr6	G1_Addr5	G1_Addr4	G1_Addr3	G1_Addr2	G1_Addr1	G1_Addr0	EnG1Addr
		1	0	0	0	0	0	X	0
1Bh	Individual Chip Addr page 41	Ind_Addr6	Ind_Addr5	Ind_Addr4	Ind_Addr3	Ind_Addr2	Ind_Addr1	Ind_Addr0	Enable
		1	0	0	0	0	0	X	0
1Ch	Chip ID page 41	ID3	ID2	ID1	ID0	Rev3	Rev2	Rev1	Rev0
		0	1	1	0	X	X	X	X

7. CS3318 REGISTER DESCRIPTIONS

Notes:

1. When addressing the CS3318 with the Individual Chip Address, all registers are read/write in I²C Mode and write-only in SPI Mode, unless otherwise noted.
2. When addressing the CS3318 with the Group Chip Addresses, all registers are write-only in both I²C and SPI Mode.

7.1 Ch 1-8 Volume - Addresses 01h - 08h

7	6	5	4	3	2	1	0
Vol7	Vol6	Vol5	Vol4	Vol3	Vol2	Vol1	Vol0

7.1.1 Volume Control (Bits 7:0)

Default = 11010010

Function:

The individual volume control registers allow the user to gain or attenuate the respective channels in 0.5 dB increments. The volume changes are implemented as dictated by the ZCMode[1:0] and TimeOut[2:0] bits in the Device Config 2 register (see [“Device Configuration 2 - Address 0Ch” on page 34](#)).

The value of the Volume Control register is mapped to the desired 0.5 dB step volume setting by the following equation:

$$\text{Register Value} = (2 \times \text{Desired Volume Setting in dB}) + 210$$

In the equation above, “Desired Volume Setting in dB” is determined by rounding the desired ¼ dB resolution volume setting down to ½ dB resolution.

It should be noted that input values outside the CS3318’s analog range of +22 dB to -96 dB are valid, however, the volume of each channel will be limited to the CS3318’s analog range (see [“Volume Limits” on page 20](#)).

Register Setting	Gain or Attenuation (dB)*
11111110	+22
11111101	+21.5
11111100	+21
-	-
11010100	+1
11010011	+0.5
11010010	0
11010001	-0.5
11010000	-1
-	-
00010100	-95
00010011	-95.5
00010010	-96

* QuarterX = ‘0’. See “¼ dB Control (Bit 0 - 7)” on page 32.

Table 5. Example Volume Settings

7.2 ¼ dB Control - Address 09h

7	6	5	4	3	2	1	0
Quarter8	Quarter7	Quarter6	Quarter5	Quarter4	Quarter3	Quarter2	Quarter1

7.2.1 ¼ dB Control (Bit 0 - 7)

Default = 0

Function:

When set, ¼ dB of gain will be added to each bit's respective channel. The volume changes are implemented as dictated by the ZCMode[1:0] and TimeOut[2:0] bits in the Device Config 2 register (see "Device Configuration 2 - Address 0Ch" on page 34).

It should be noted that input values outside the CS3318's analog range of +22 dB to -96 dB are valid; however, the volume of each channel will be limited to the CS3318's analog range (see "Volume Limits" on page 20).

Table 6 shows example volume settings using the ¼ dB control.

Volume Control Register Setting (Reg 01h - 08h)	Corresponding QuarterX Bit Setting	Individual Volume _{ChX} (dB)
11111110	0	+22
11111101	1	+21.75
11111101	0	+21.5
11111100	1	+21.25
11111100	0	+21
-	-	-
11010100	0	+1
11010011	1	+0.75
11010011	0	+0.5
11010010	1	+0.25
11010010	0	0
11010001	1	-0.25
11010001	0	-0.5
11010000	1	-0.75
11010000	0	-1
-	-	-
00010100	0	-95
00010011	1	-95.25
00010011	0	-95.5
00010010	1	-95.75
00010010	0	-96

Table 6. Example Volume Settings

7.3 Mute Control - Address 0Ah

7	6	5	4	3	2	1	0
MuteCh8	MuteCh7	MuteCh6	MuteCh5	MuteCh4	MuteCh3	MuteCh2	MuteCh1

7.3.1 Mute Channel X (Bit 0 - 7)

Default = 0

Function:

Each bit controls the individual mute state of its respective channel. When set, the mute condition is active. When cleared, the mute condition is released.

See “[Muting Controls](#)” on page 21 for more information about the muting behavior of the CS3318.

7.4 Device Configuration 1 - Address 0Bh (Bit 5)

7	6	5	4	3	2	1	0
Reserved	Reserved	EnMuteIn	MutePolarity	Ch8=7	Ch6=5	Ch4=3	Ch2=1

7.4.1 Enable $\overline{\text{MUTE}}$ Input (Bit 5)

Default = 1

Function:

When set, the $\overline{\text{MUTE}}$ input pin is enabled and will generate a mute condition when active. When cleared, the $\overline{\text{MUTE}}$ input pin is ignored and will not generate a mute condition.

7.4.2 $\overline{\text{MUTE}}$ Input Polarity (Bit 4)

Default = 0

Function:

This bit controls the active level of the $\overline{\text{MUTE}}$ input pin.

When set, the mute condition is active when the $\overline{\text{MUTE}}$ pin is high. When cleared, the mute condition is active when the $\overline{\text{MUTE}}$ pin is low.

7.4.3 Channel B = Channel A (Bit 0 - 3)

Default = 0

Function:

When this bit is set, Channel A and Channel B volume levels and muting conditions are controlled by the Channel A volume and muting register settings, and the Channel B register settings are ignored.

When this bit is cleared, Channel A and Channel B volume and mute settings are independently controlled by the A and B volume and muting bits.

Bit Name	Bit Setting	Control Configuration
Ch8=7	0	Channel 7 and 8 mute and volume settings controlled independently
	1	Channel 7 and 8 mute and volume settings controlled by Channel 7 register settings. Channel 8 register settings are ignored.
Ch6=5	0	Channel 5 and 6 mute and volume settings controlled independently
	1	Channel 5 and 6 mute and volume settings controlled by Channel 5 register settings. Channel 6 register settings are ignored.
Ch4=3	0	Channel 3 and 4 mute and volume settings controlled independently
	1	Channel 3 and 4 mute and volume settings controlled by Channel 3 register settings. Channel 4 register settings are ignored
Ch2=1	0	Channel 1 and 2 mute and volume settings controlled independently
	1	Channel 1 and 2 mute and volume settings controlled by Channel 1 register settings. Channel 2 register settings are ignored

Table 7. Channel B = Channel A Settings

7.5 Device Configuration 2 - Address 0Ch

7	6	5	4	3	2	1	0
Reserved	Reserved	Reserved	TimeOut2	TimeOut1	TimeOut0	ZCMode1	ZCMode0

7.5.1 Zero-Crossing Time-Out Period (Bits 4:2)

Default = 011

Function:

These bits set the zero-crossing time-out period as shown in [Table 9](#). Refer to the “Zero-Crossing Time-Out” section on page 22 for more information.

TimeOut[2:0]	Zero-Crossing Time-Out Period
000	5 ms
001	10 ms
010	15 ms
011	18 ms
100	20 ms
101	30 ms
110	40 ms
111	50 ms

Table 8. Zero-Crossing Time-Out Settings

7.5.2 Zero-Crossing Mode (Bits 1:0)

Default = 01

Function:

These bits control the Zero-Crossing detection mode as shown in Table 9. Refer to the “Zero-Crossing Modes” section on page 22 for more information.

ZCMode[1:0]	Zero-Crossing Mode
00	Volume changes take effect immediately.
01	Volume changes take effect on a signal zero-crossing. If a zero-crossing is not detected before the period specified by the TimeOut[2:0] bits has elapsed, the volume change will be implemented immediately when the time-out period elapses. If the volume setting is changed again before the original volume change has been implemented, the original change will be discarded, the time-out period will be reset, and the new volume setting will take effect when a zero-crossing is detected or the time-out period elapses.
10	Volume changes take effect on a signal zero-crossing. If a zero-crossing is not detected before the period specified by the TimeOut[2:0] bits has elapsed, the volume change will be implemented immediately when the time-out period elapses. If the volume setting is changed again before the original volume change has been implemented, the original volume change will be implemented immediately upon reception of the new volume change command, the time-out period will be reset, and the new volume setting will take effect when a zero-crossing is detected or the time-out period elapses.
11	Reserved

Table 9. Zero-Crossing Mode Settings

7.6 Channel Power - Address 0Dh

7	6	5	4	3	2	1	0
PDN8	PDN7	PDN6	PDN5	PDN4	PDN3	PDN2	PDN1

7.6.1 Power Down Channel X (Bit 0 - 7)

Default = 0

Function:

Each respective channel will enter a low-power state whenever this bit is set. A channel’s power-down bit must be cleared for normal operation to occur.

7.7 Master Power - Address 0Eh

7	6	5	4	3	2	1	0
Reserved	Reserved	Reserved	Reserved	Reserved	Reserved	Reserved	PDN_ALL

7.7.1 Power Down All (Bit 0)

Default = 1

Function:

The device will enter a low-power state whenever this bit is set. The power-down bit is set by default and must be cleared before normal operation can occur. The control registers remain accessible, and their contents are retained while the device is in power-down.

7.8 Freeze Control - Address 0Fh

7	6	5	4	3	2	1	0
Reserved	Reserved	Reserved	Reserved	Reserved	Reserved	Reserved	Freeze

7.8.1 Freeze (Bit 7)

Default = 0

Function:

When the Freeze bit is set, the Freeze function allows modifications to the control port registers without changes taking effect until Freeze bit is cleared. To make multiple changes in the Control Port registers take effect simultaneously, set the Freeze bit, make all register changes, then clear the Freeze bit.

7.9 Master 1 Mask - Address 10h

7	6	5	4	3	2	1	0
M1_Ch8M	M1_Ch7M	M1_Ch6M	M1_Ch5M	M1_Ch4M	M1_Ch3M	M1_Ch2M	M1_Ch1M

Each bit in this register serves as a Master 1 mask for its corresponding channel.

If a mask bit is set to '1', the corresponding channel is unmasked, meaning that it will be affected by the Master 1 volume and muting controls.

If a mask bit is set to '0', the corresponding channel is masked, meaning that it will not be affected by the Master 1 volume and muting controls.

This register defaults to FFh (all channels unmasked).

7.10 Master 1 Volume - Address 11h

7	6	5	4	3	2	1	0
M1_Vol7	M1_Vol6	M1_Vol5	M1_Vol4	M1_Vol3	M1_Vol2	M1_Vol1	M1_Vol0

7.10.1 Master 1 Volume Control (Bits 7:0)

Default = 11010010

Function:

The Master 1 volume control register allows the user to simultaneously gain or attenuate all unmasked channels in 0.5 dB increments. The volume changes are implemented as dictated by the ZC-Mode[1:0] and TimeOut[2:0] bits in the Device Config 2 register (see ["Device Configuration 2 - Address 0Ch" on page 34](#)).

The value of the Master 1 volume control register is mapped to the desired 0.5 dB step Master 1 volume setting by the following equation:

$$\text{Register Value} = (2 \times \text{Desired Volume Setting in dB}) + 210$$

In the equation above, "*Desired Volume Setting in dB*" is determined by rounding the desired ¼ dB resolution volume setting down to ½ dB resolution.

It should be noted that input values outside the CS3318's analog range of +22 dB to -96 dB are valid, however, the volume of each channel will be limited to the CS3318's analog range (see ["Volume Limits" on page 20](#)).

See [Table 5 on page 31](#) for example register settings.

7.11 Master 1 Control - Address 12h

7	6	5	4	3	2	1	0
Reserved	Reserved	Reserved	Reserved	Reserved	Reserved	M1_Mute	M1_Qtr

7.11.1 Master 1 Mute (Bit 1)

Default = 0

Function:

This bit controls the Master 1 mute state. When set, the Master 1 mute condition is active. When cleared, the Master 1 mute condition is released.

See [“Muting Controls” on page 21](#) for more information about the muting behavior of the CS3318.

7.11.2 Master 1 ¼ dB Control (Bit 0)

Default = 0

Function:

When set, ¼ dB of gain will be added to the Master 1 volume level.

See [Table 6 on page 32](#) for an example of volume settings using the ¼ dB control.

7.12 Master 2 Mask - Address 13h

7	6	5	4	3	2	1	0
M2_Ch8M	M2_Ch7M	M2_Ch6M	M2_Ch5M	M2_Ch4M	M2_Ch3M	M2_Ch2M	M2_Ch1M

Each bit in this register serves as a Master 2 mask for its corresponding channel.

If a mask bit is set to ‘1’, the corresponding channel is unmasked, meaning that it will be affected by the Master 2 volume and muting controls.

If a mask bit is set to ‘0’, the corresponding channel is masked, meaning that it will not be affected by the Master 2 volume and muting controls.

This register defaults to FFh (all channels unmasked).

7.13 Master 2 Volume - Address 14h

7	6	5	4	3	2	1	0
M2_Vol7	M2_Vol6	M2_Vol5	M2_Vol4	M2_Vol3	M2_Vol2	M2_Vol1	M2_Vol0

7.13.1 Master 2 Volume Control (Bits 7:0)

Default = 11010010

Function:

The Master 2 volume control register allows the user to simultaneously gain or attenuate all unmasked channels from +22 dB to -96 dB in 0.5 dB increments. The volume changes are implemented as dictated by the ZCMode[1:0] and TimeOut[2:0] bits in the Device Config 2 register (see [“Device Configuration 2 - Address 0Ch” on page 34](#)).

The value of the Master 2 volume control register is mapped to the desired 0.5 dB step Master 2 volume setting by the following equation:

$$\text{Register Value} = (2 \times \text{Desired Volume Setting in dB}) + 210$$

In the equation above, “*Desired Volume Setting in dB*” is determined by rounding the desired ¼ dB resolution volume setting down to ½ dB resolution.

It should be noted that input values outside the CS3318’s analog range of +22 dB to -96 dB are valid; however, the volume of each channel will be limited to the CS3318’s analog range (see “[Volume Limits](#)” on page 20).

See [Table 5 on page 31](#) for example register settings.

7.14 Master 2 Control - Address 15h

7	6	5	4	3	2	1	0
Reserved	Reserved	Reserved	Reserved	Reserved	Reserved	M2_Mute	M2_Qtr

7.14.1 Master 2 Mute (Bit 1)

Default = 0

Function:

This bit controls the Master 2 mute state. When set, the Master 1 mute condition is active. When cleared, the Master 2 mute condition is released.

See “[Muting Controls](#)” on page 21 for more information about the muting behavior of the CS3318.

7.14.2 Master 2 ¼ dB Control (Bit 0)

Default = 0

Function:

When set, ¼ dB of gain will be added to the Master 2 volume level.

See [Table 6 on page 32](#) for an example of volume settings using the ¼ dB control.

7.15 Master 3 Mask - Address 16h

7	6	5	4	3	2	1	0
M3_Ch8M	M3_Ch7M	M3_Ch6M	M3_Ch5M	M3_Ch4M	M3_Ch3M	M3_Ch2M	M3_Ch1M

Each bit in this register serves as a Master 3 mask for its corresponding channel.

If a mask bit is set to ‘1’, the corresponding channel is unmasked, meaning that it will be affected by the Master 3 volume and muting controls.

If a mask bit is set to ‘0’, the corresponding channel is masked, meaning that it will not be affected by the Master 3 volume and muting controls.

This register defaults to FFh (all channels unmasked).

7.16 Master 3 Volume - Address 17h

7	6	5	4	3	2	1	0
M3_Vol7	M3_Vol6	M3_Vol5	M3_Vol4	M3_Vol3	M3_Vol2	M3_Vol1	M3_Vol0

7.16.1 Master 3 Volume Control (Bits 7:0)

Default = 11010010

Function:

The Master 3 volume control register allows the user to simultaneously gain or attenuate all unmasked channels from +22 dB to -96 dB in 0.5 dB increments. The volume changes are implemented

as dictated by the ZCMode[1:0] and TimeOut[2:0] bits in the Device Config 2 register (see [“Device Configuration 2 - Address 0Ch” on page 34](#)).

The value of the Master 3 volume control register is mapped to the desired 0.5 dB step Master 3 volume setting by the following equation:

$$\text{Register Value} = (2 \times \text{Desired Volume Setting in dB}) + 210$$

In the equation above, “*Desired Volume Setting in dB*” is determined by rounding the desired ¼ dB resolution volume setting down to ½ dB resolution.

It should be noted that input values outside the CS3318’s analog range of +22 dB to -96 dB are valid, however, the volume of each channel will be limited to the CS3318’s analog range (see [“Volume Limits” on page 20](#)).

See [Table 5 on page 31](#) for example register settings.

7.17 Master 3 Control - Address 18h

7	6	5	4	3	2	1	0
Reserved	Reserved	Reserved	Reserved	Reserved	Reserved	M3_Mute	M3_Qtr

7.17.1 Master 3 Mute (Bit 1)

Default = 0

Function:

This bit controls the Master 3 mute state. When set, the Master 3 mute condition is active. When cleared, the Master 3 mute condition is released.

See [“Muting Controls” on page 21](#) for more information about the muting behavior of the CS3318.

7.17.2 Master 3 ¼ dB Control (Bit 0)

Default = 0

Function:

When set, ¼ dB of gain will be added to the Master 3 volume level.

See [Table 6 on page 32](#) for an example of volume settings using the ¼ dB control.

7.18 Group 2 Chip Address 19h

7	6	5	4	3	2	1	0
G2_Addr6	G2_Addr5	G2_Addr4	G2_Addr3	G2_Addr2	G2_Addr1	G2_Addr0	EnG2Addr

7.18.1 Group 2 Chip Address (Bits 7:1)

SPI Mode Default = 1000000b

I²C Mode Default = See [Table 4 on page 27](#).

Function:

These bits set the Group 2 chip address, and may be modified at any time. See “[System Serial Control Configuration](#)” on page 23 and “[I²C/SPI Serial Control Formats](#)” on page 27 for more information.

7.18.2 Enable Group 2 Address (Bit 0)

Default = 0

Function:

This bit controls the device’s recognition of the Group 2 address. When set, the device will respond to serial communication when addressed with the Group 2 address. When cleared, the device will ignore all serial communication when addressed with the Group 2 address.

7.19 Group 1 Chip Address 1Ah

7	6	5	4	3	2	1	0
G1_Addr6	G1_Addr5	G1_Addr4	G1_Addr3	G1_Addr2	G1_Addr1	G1_Addr0	EnG1Addr

7.19.1 Group 1 Chip Address (Bits 7:1)

SPI Mode Default = 1000000b

I²C Mode Default = See [Table 4 on page 27](#).

Function:

These bits set the Group 1 chip address, and may be modified at any time. See “[System Serial Control Configuration](#)” on page 23 and “[I²C/SPI Serial Control Formats](#)” on page 27 for more information.

7.19.2 Enable Group 1 Address (Bit 0)

Default = 0

Function:

This bit controls the device’s recognition of the Group 1 address. When set, the device will respond to serial communication when addressed with the Group 1 address. When cleared, the device will ignore all serial communication when addressed with the Group 1 address.

7.20 Individual Chip Address 1Bh

7	6	5	4	3	2	1	0
Ind_Addr6	Ind_Addr5	Ind_Addr4	Ind_Addr3	Ind_Addr2	Ind_Addr1	Ind_Addr0	Enable

7.20.1 Individual Chip Address (Bits 7:1)

SPI Mode Default = 1000000b

I²C Mode Default = See [Table 4](#) on page 27

Function:

These bits set the individual chip address, and may be modified at any time. See “[System Serial Control Configuration](#)” on page 23 and “[I²C/SPI Serial Control Formats](#)” on page 27 for more information.

7.20.2 Enable Next Device (Bit 0)

Default = 0

Function:

When set, the CS3318’s enable output pin (ENOut) will be driven high. When cleared, the CS3318’s enable output pin (ENOut) will be driven low.

7.21 Chip ID - Address 1Ch

7	6	5	4	3	2	1	0
ID3	ID2	ID1	ID0	Rev3	Rev2	Rev1	Rev0

This is a Read-Only register.

7.21.1 Chip ID (Bits 7:4)

Default = 0110b

Function:

Chip ID code for the CS3318. Permanently set to 0110.

7.21.2 Chip Revision (Bits 3:0)

Default = xxxxb

Function:

Chip revision code for the CS3318. Encoded as shown in [Table 10](#).

Chip Revision	Register Code
A0, B0	0000b

Table 10. Chip Revision Register Codes

8. PARAMETER DEFINITIONS

Dynamic Range

Full-scale (RMS) signal to broadband noise ratio. The broadband noise is measured over the specified bandwidth with the input grounded. Expressed in decibels.

Total Harmonic Distortion + Noise

The ratio of the rms value of the signal to the rms sum of all other spectral components over the specified bandwidth (typically 10 Hz to 20 kHz), including distortion components. Expressed in decibels.

Frequency Response

A measure of the amplitude response variation from 10 Hz to 20 kHz relative to the amplitude response at 1 kHz. Units in decibels.

Interchannel Isolation

A measure of crosstalk between channels. Measured for each channel at the device's output with a full-scale signal applied to one channel adjacent to the channel under test, and no signal applied to all other channels. Units in decibels.

Gain Error

The deviation from the nominal full-scale analog output for a full-scale digital input.

Gain Drift

The change in gain value with temperature. Units in ppm/°C.

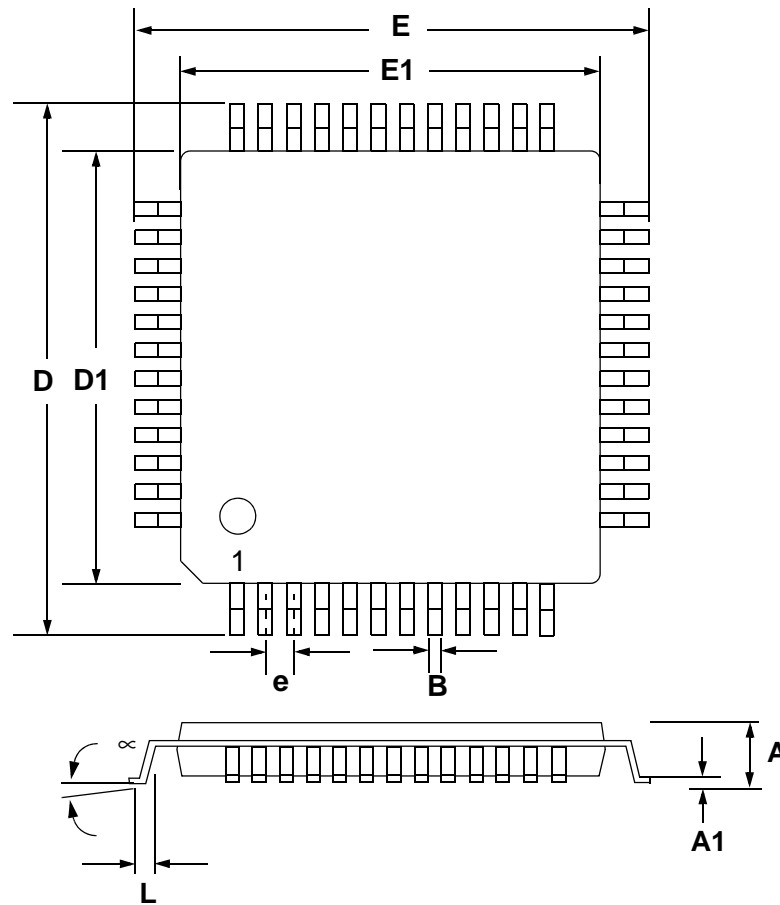
9. PACKAGE DIMENSIONS
48L LQFP PACKAGE DRAWING

DIM	INCHES			MILLIMETERS		
	MIN	NOM	MAX	MIN	NOM	MAX
A	---	0.055	0.063	---	1.40	1.60
A1	0.002	0.004	0.006	0.05	0.10	0.15
B	0.007	0.009	0.011	0.17	0.22	0.27
D	0.343	0.354	0.366	8.70	9.0 BSC	9.30
D1	0.272	0.28	0.280	6.90	7.0 BSC	7.10
E	0.343	0.354	0.366	8.70	9.0 BSC	9.30
E1	0.272	0.28	0.280	6.90	7.0 BSC	7.10
e*	0.016	0.020	0.024	0.40	0.50 BSC	0.60
L	0.018	0.24	0.030	0.45	0.60	0.75
∞	0.000°	4°	7.000°	0.00°	4°	7.00°

* Nominal pin pitch is 0.50 mm

*Controlling dimension is mm.

*JEDEC Designation: MS022

10.THERMAL CHARACTERISTICS AND SPECIFICATIONS

Parameters	Symbol	Min	Typ	Max	Units
Package Thermal Resistance (Note 1)	48-LQFP				
	θ_{JA}	-	48	-	°C/Watt
	θ_{JC}	-	15	-	°C/Watt
Allowable Junction Temperature		-	-	125	°C

1. θ_{JA} is specified according to JEDEC specifications for multi-layer PCBs.

11. ORDERING INFORMATION

Product	Description	Package	Pb-Free	Grade	Temp Range	Container	Order #
CS3318	8-Channel Analog Volume Control	48-pin LQFP	YES	Commercial	-10° to +70° C	Tray	CS3318-CQZ
						Tape & Reel	CS3318-CQZR
CDB3318	CS3318 Evaluation Board		No	-	-	-	CDB3318

12. REVISION HISTORY

Release	Changes
A1	Initial Release of Advance Datasheet
PP1	Initial Release of Preliminary Datasheet <ul style="list-style-type: none"> – Updated THD+N shown on cover page. – Updated the R_L measurement condition for the Analog Characteristics table on page 8. – Updated THD+N specification in the Analog Characteristics table on page 8 – Updated Supply Current specifications in the Analog Characteristics table on page 8. – Updated Power Consumption specification in the Analog Characteristics table on page 8. – Updated Input/Output Voltage Range specification in the Analog Characteristics table on page 8. – Updated Output Noise specification in the Analog Characteristics table on page 8. – Updated Chip Revision bit description shown on page 41.
F1	Final Release

Contacting Cirrus Logic Support

For all product questions and inquiries, contact a Cirrus Logic Sales Representative.
To find the one nearest you, go to www.cirrus.com.

IMPORTANT NOTICE

Cirrus Logic, Inc. and its subsidiaries ("Cirrus") believe that the information contained in this document is accurate and reliable. However, the information is subject to change without notice and is provided "AS IS" without warranty of any kind (express or implied). Customers are advised to obtain the latest version of relevant information to verify, before placing orders, that information being relied on is current and complete. All products are sold subject to the terms and conditions of sale supplied at the time of order acknowledgment, including those pertaining to warranty, indemnification, and limitation of liability. No responsibility is assumed by Cirrus for the use of this information, including use of this information as the basis for manufacture or sale of any items, or for infringement of patents or other rights of third parties. This document is the property of Cirrus and by furnishing this information, Cirrus grants no license, express or implied under any patents, mask work rights, copyrights, trademarks, trade secrets or other intellectual property rights. Cirrus owns the copyrights associated with the information contained herein and gives consent for copies to be made of the information only for use within your organization with respect to Cirrus integrated circuits or other products of Cirrus. This consent does not extend to other copying such as copying for general distribution, advertising or promotional purposes, or for creating any work for resale.

CERTAIN APPLICATIONS USING SEMICONDUCTOR PRODUCTS MAY INVOLVE POTENTIAL RISKS OF DEATH, PERSONAL INJURY, OR SEVERE PROPERTY OR ENVIRONMENTAL DAMAGE ("CRITICAL APPLICATIONS"). CIRRUS PRODUCTS ARE NOT DESIGNED, AUTHORIZED OR WARRANTED FOR USE IN AIRCRAFT SYSTEMS, MILITARY APPLICATIONS, PRODUCTS SURGICALLY IMPLANTED INTO THE BODY, AUTOMOTIVE SAFETY OR SECURITY DEVICES, LIFE SUPPORT PRODUCTS OR OTHER CRITICAL APPLICATIONS. INCLUSION OF CIRRUS PRODUCTS IN SUCH APPLICATIONS IS UNDERSTOOD TO BE FULLY AT THE CUSTOMER'S RISK AND CIRRUS DISCLAIMS AND MAKES NO WARRANTY, EXPRESS, STATUTORY OR IMPLIED, INCLUDING THE IMPLIED WARRANTIES OF MERCHANTABILITY AND FITNESS FOR PARTICULAR PURPOSE, WITH REGARD TO ANY CIRRUS PRODUCT THAT IS USED IN SUCH A MANNER. IF THE CUSTOMER OR CUSTOMER'S CUSTOMER USES OR PERMITS THE USE OF CIRRUS PRODUCTS IN CRITICAL APPLICATIONS, CUSTOMER AGREES, BY SUCH USE, TO FULLY INDEMNIFY CIRRUS, ITS OFFICERS, DIRECTORS, EMPLOYEES, DISTRIBUTORS AND OTHER AGENTS FROM ANY AND ALL LIABILITY, INCLUDING ATTORNEYS' FEES AND COSTS, THAT MAY RESULT FROM OR ARISE IN CONNECTION WITH THESE USES.

Cirrus Logic, Cirrus, and the Cirrus Logic logo designs are trademarks of Cirrus Logic, Inc. All other brand and product names in this document may be trademarks or service marks of their respective owners.

IPIC is a registered trademark of Philips Semiconductor.

SPI is a trademark of Motorola, Inc.

Mouser Electronics

Authorized Distributor

Click to View Pricing, Inventory, Delivery & Lifecycle Information:

[Cirrus Logic:](#)

[CDB3318](#) [CS3318-CQZ](#)

Компания «Океан Электроники» предлагает заключение долгосрочных отношений при поставках импортных электронных компонентов на взаимовыгодных условиях!

Наши преимущества:

- Поставка оригинальных импортных электронных компонентов напрямую с производств Америки, Европы и Азии, а так же с крупнейших складов мира;
- Широкая линейка поставок активных и пассивных импортных электронных компонентов (более 30 млн. наименований);
- Поставка сложных, дефицитных, либо снятых с производства позиций;
- Оперативные сроки поставки под заказ (от 5 рабочих дней);
- Экспресс доставка в любую точку России;
- Помощь Конструкторского Отдела и консультации квалифицированных инженеров;
- Техническая поддержка проекта, помощь в подборе аналогов, поставка прототипов;
- Поставка электронных компонентов под контролем ВП;
- Система менеджмента качества сертифицирована по Международному стандарту ISO 9001;
- При необходимости вся продукция военного и аэрокосмического назначения проходит испытания и сертификацию в лаборатории (по согласованию с заказчиком);
- Поставка специализированных компонентов военного и аэрокосмического уровня качества (Xilinx, Altera, Analog Devices, Intersil, Interpoint, Microsemi, Actel, Aeroflex, Peregrine, VPT, Syfer, Eurofarad, Texas Instruments, MS Kennedy, Miteq, Cobham, E2V, MA-COM, Hittite, Mini-Circuits, General Dynamics и др.);

Компания «Океан Электроники» является официальным дистрибьютором и эксклюзивным представителем в России одного из крупнейших производителей разъемов военного и аэрокосмического назначения «JONHON», а так же официальным дистрибьютором и эксклюзивным представителем в России производителя высокотехнологичных и надежных решений для передачи СВЧ сигналов «FORSTAR».



JONHON

«JONHON» (основан в 1970 г.)

Разъемы специального, военного и аэрокосмического назначения:

(Применяются в военной, авиационной, аэрокосмической, морской, железнодорожной, горно- и нефтедобывающей отраслях промышленности)

«FORSTAR» (основан в 1998 г.)

ВЧ соединители, коаксиальные кабели, кабельные сборки и микроволновые компоненты:

(Применяются в телекоммуникациях гражданского и специального назначения, в средствах связи, РЛС, а так же военной, авиационной и аэрокосмической отраслях промышленности).



Телефон: 8 (812) 309-75-97 (многоканальный)

Факс: 8 (812) 320-03-32

Электронная почта: ocean@oceanchips.ru

Web: <http://oceanchips.ru/>

Адрес: 198099, г. Санкт-Петербург, ул. Калинина, д. 2, корп. 4, лит. А