

QSL RF Connector System

DESCRIPTION

Coaxial Cable Insulation Displacement Interface

- Low profile
- Highly reliable ruggedized interface
- Surface mount technology
- Excellent price-to-performance ratio

APPLICATIONS

- Replacements for SMA, BNC, and other RF Connectors
- Mobile Antenna / GPS / Radio Systems
- PDA / PCS / Handheld applications
- Wireless Communications systems
- Satellite Communications, Broadcast, Multimedia
- Automotive Telematics
- WiFi, WiMax Antenna Mobility & Communications
- Broadcast / Set Top Box and Integration Media
- PCIe and WNIC Cards

KEY FEATURES

- Surface and Panel Mount Compatible
- RoHS Compliant [Lead-free SMT process (260° C) compatible]
- Designed for RG 174 & RG 316 Cable
- 3 port QSL footprint
12.5 mm D x 17.5 mm W x 10mmH
- 10 mm x 10.6 mm max. footprint (w/o panel extension)
- IP67 compatible designs available upon request
- Platform expandable for multiple ports, configuration, and color options

FOR MORE INFORMATION

Internet

<http://tycoelectronics.com/products/rfcoax>

Technical Support Center

Phone: 1-800-522-6752

E-mail: product.info@amp.com

Product Specification/ Design Objectives:

108-2324 PCB Receptacles

108-2302 Panel Mount Receptacles

108-2307 Antennas

Global Product Manager — Claude de Lorraine

Phone: 717-986-5793

E-mail: cdeborraine@tycoelectronics.com

Europe Product Manager — Patrick Duquerroy

Phone: (49) 61824538

E-mail: pduquerroy@tycoelectronics.com

US Product Manager — Dave Gravina

Phone: 717-329-5657

E-mail: gravinad@tycoelectronics.com

Asia Product Manager — Alex Yeh

Phone: 2-87682788 EXT297

E-mail: alex.yeh@tycoelectronics.com

PCB RECEPTACLES

Single Port Receptacle

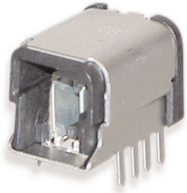

Part Number
1274794-1

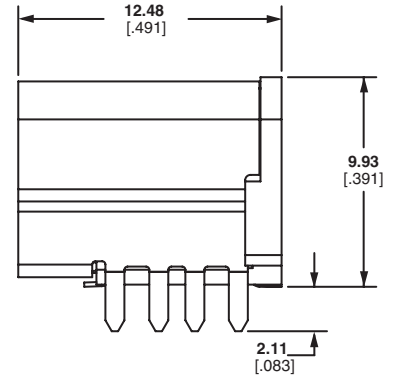
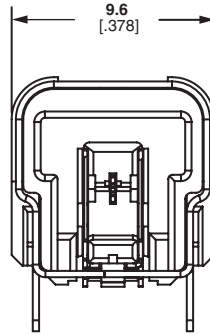

Three Port Receptacle

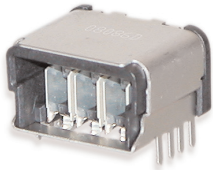

Part Number
2016032-1

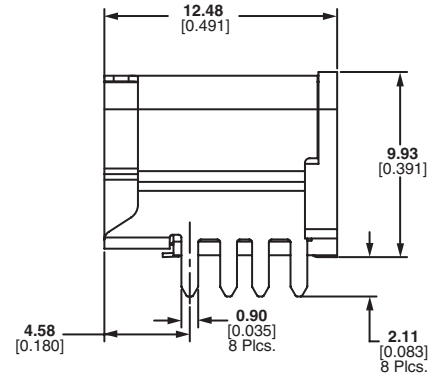
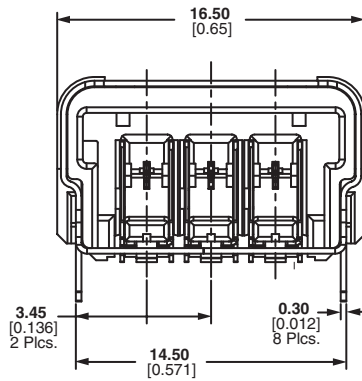

Three Port Flange Receptacle

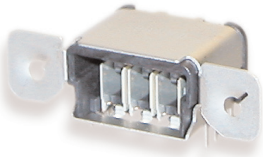

Part Number
1274824-2

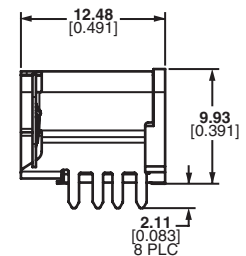
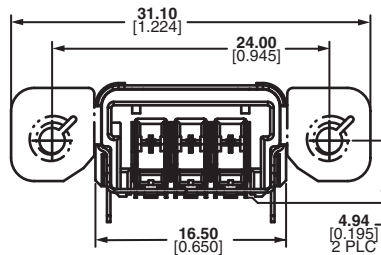
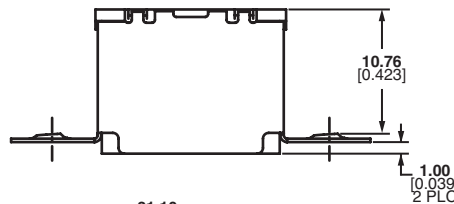

Dimensions are millimeters over inches unless otherwise specified.

ELECTRICAL

SINGLE PORT BOARD MOUNT

THREE PORT BOARD MOUNT

Characteristic Impedance:	50 Ohms*	50 Ohms*
Frequency Range:	DC — 6 GHz	DC — 6 GHz
VSWR:**		
DC — 3 GHz	1.3 max	1.3 max
3 — 6 GHz	1.45 max	1.45 max
Insertion Loss:		
DC — 3 GHz	0.30 dB max	0.30 dB max
3 — 6 GHz	0.40 dB max	0.40 dB max
Rated voltage:	60 VAC (rms)	60 VAC (rms)
Rated Current Per Port:	5 A max	5 A max
Diel. Withstanding Voltage:		
(50Hz for 1 min at sea level)	800 VAC	800 VAC
Insulation Resistance:	100 Megohms min	100 Megohms min
Contact Resistance:		
Center:	20 milliohms max	20 milliohms max
Outer:	20 milliohms max	20 milliohms max

*75 Ohm available upon request

** Mated Pair

MECHANICAL/ ENVIRONMENTAL

SINGLE PORT

THREE PORT

Engagement Force:	< 30 N	< 40 N
Disengagement Force:	< 20 N	< 30 N
Cable Retention:	> 89 N	> 110 N
Operating Temperature:	- 40 to + 85°C	- 40 to + 85°C
Durability:	500 cycles	500 cycles

MATERIAL AND FINISH

Part Description	Material	Finish
Housing (Cable Plug)	PBT	Black, UL 94V-0
Housing (Receptacle)	LCP	Black, UL 94V-0
Hold Downs / Shell	Copper Alloy	Sn over Ni
Shield & Strain Relief (Cable Plug)	Copper Alloy	*
Shield (Recpt)	Copper Alloy	*
Center Contact (Cable and recpt)	Copper Alloy	*
Insulator (Cable Plug)	PBT	Black UL 94HB

* Conforms to the requirements of EIA/ECA-364-1000.01A (controlled environment applications), and Tyco Electronics production specification 108-2324.

CABLE ASSEMBLIES, RECEPTACLE, PANEL MOUNT, 3 PORT PUSH IN

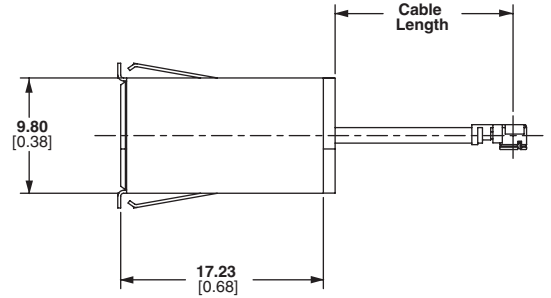
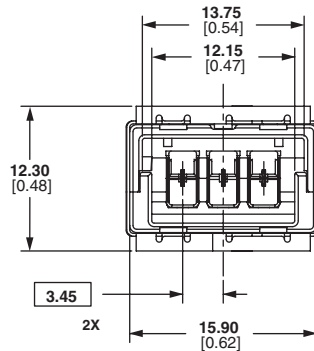
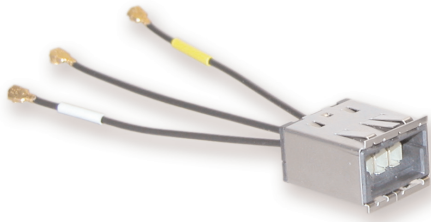

QSL Vista

For Standard PCI Brackets (1.00mm THR)

Part Number	Cable Length
1274999-1	63.5mm [2.5"]
1274999-2	130.0mm [5.12"]
1274999-3	508.0mm [20.0"]

Note: Pigtails use 1.32mm dia, double braid coax cable and are terminated with Style A UMCC cable connectors.

QSL CONNECTOR MATED PAIR VSWR TEST BOARDS

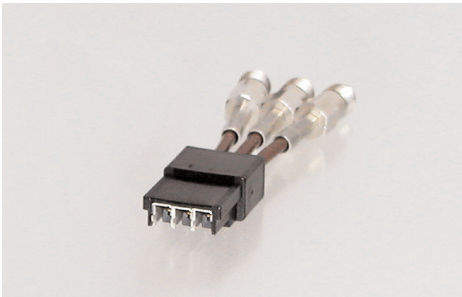

Test dongle, QSL to SMA
Part Number 2032605-1

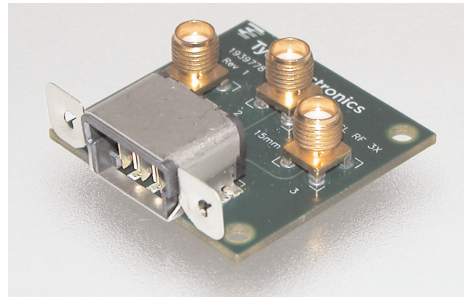

Test board with Receptacle,
QSL to SMA
Part Number 1513743-1

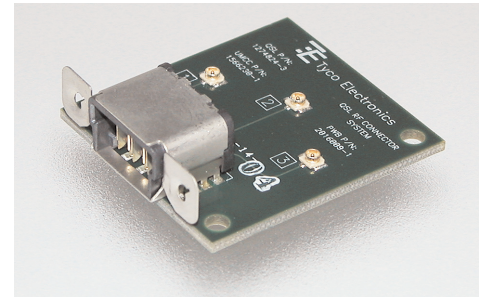

Test board with Receptacle,
QSL to UMCC
Part Number 2016008-1

Technical Documents:

Instruction Sheet:

408-10212 QSL Connector Mated Pair
VSWR Test Procedure

JUMPER AND PIGTAIL CABLE PLUG ASSEMBLIES

All jumpers and pigtails use RG-174 cable.

QSL Single Port Jumper Cable Plug Assembly



Part Number
2015911-1

QSL Single Port Pigtail Cable Plug Assembly



Part Number
2015706-1

QSL Three Port Without Flange Jumper Cable Plug Assembly

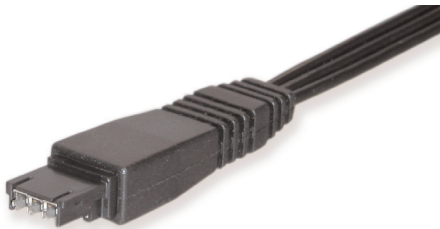

Part Number
2015518-1

QSL Three Port With Flange Pigtail Cable Plug Assembly

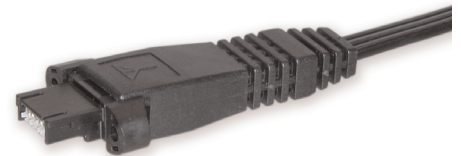

Part Number
2053075-1

FOR MORE INFORMATION ON QSL CABLE ASSEMBLY APPLICATION CONTACT

Product Manager — David Stonfer
Phone: 717-986-5950
E-mail: david.stonfer@tycoelectronics.com

3 PORT CABLE PLUG WITH ANTENNA MODULE ASSEMBLY

Straight Cable Plug 3 port with Antenna Module Assembly

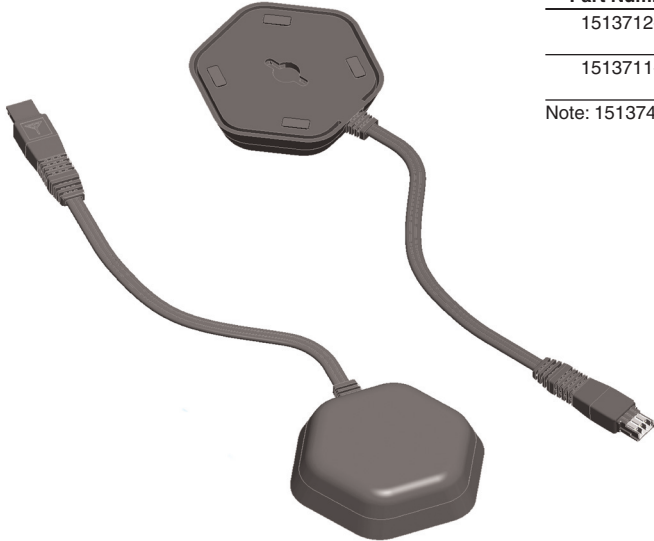

Part Number	Cable	Length	Antenna Type
1513712-1	RG-174	0.8 meters	802.11 a/b/g/n and WiMax antenna assembly w/flange
1513711-1	RG-174	0.8 meters	802.11 a/b/g/n and WiMax antenna assembly w/o flange

Note: 1513743-1 Test Board Adapter Available for VSWR Testing

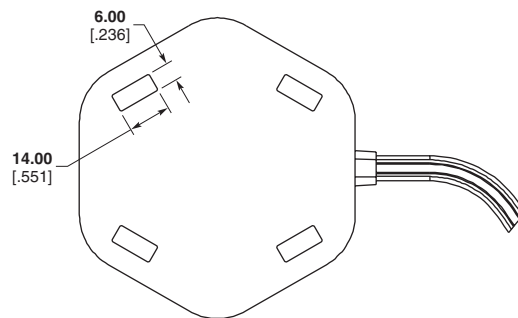
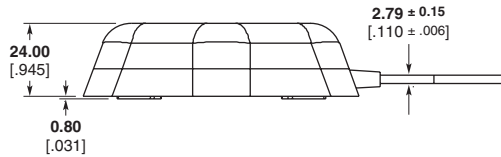
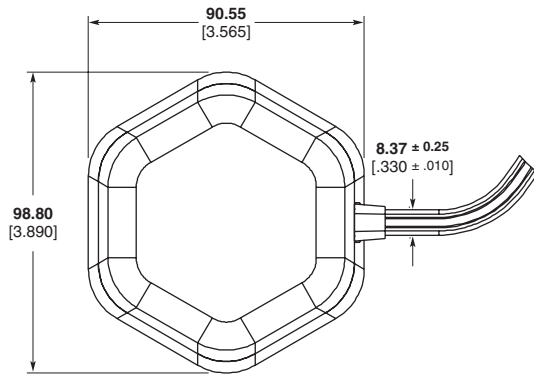

FOR MORE INFORMATION

Global Product Manager —

Frank Basile

Mobile: 408-234-7737

E-mail: fjb@tycoelectronics.com

Global Engineering Manager —

Bruce Bishop

Phone: 831-662-1154

E-mail: bbishop@tycoelectronics.com

Dimensions are millimeters over inches unless otherwise specified.

3 PORT CABLE PLUG WITH ANTENNA MODULE ASSEMBLY

MIMO Triple Dipole 802.11a/b/g/n Antenna Module Assembly with 3 Port QSL Connector



3X RGI74 flat terminated with Tyco Electronics 3-port QSLConnector

Specifications

Frequency Range (GHz)	2.4 – 2.4835; 4.9 – 5.875 GHz
Azimuth Gain at connector (Ave.)	-2 dBi @ 2.4 GHz -4 dBi @ 5 GHz
Return Loss	< -10 dB
VSWR	< 2.0:1
Operating Temperature	-40°C to 70°C
Polarization	Vertical
Power Handling	10 Watts max.
Feed Point Impedance	50 Ohms
Size	95mm x 85mm dia.
Weight	180g.

Part Number	Cable
1513837-1	3X RG-174 or equivalent

Note: 1513743-1 Test Board Adapter Available for VSWR Testing

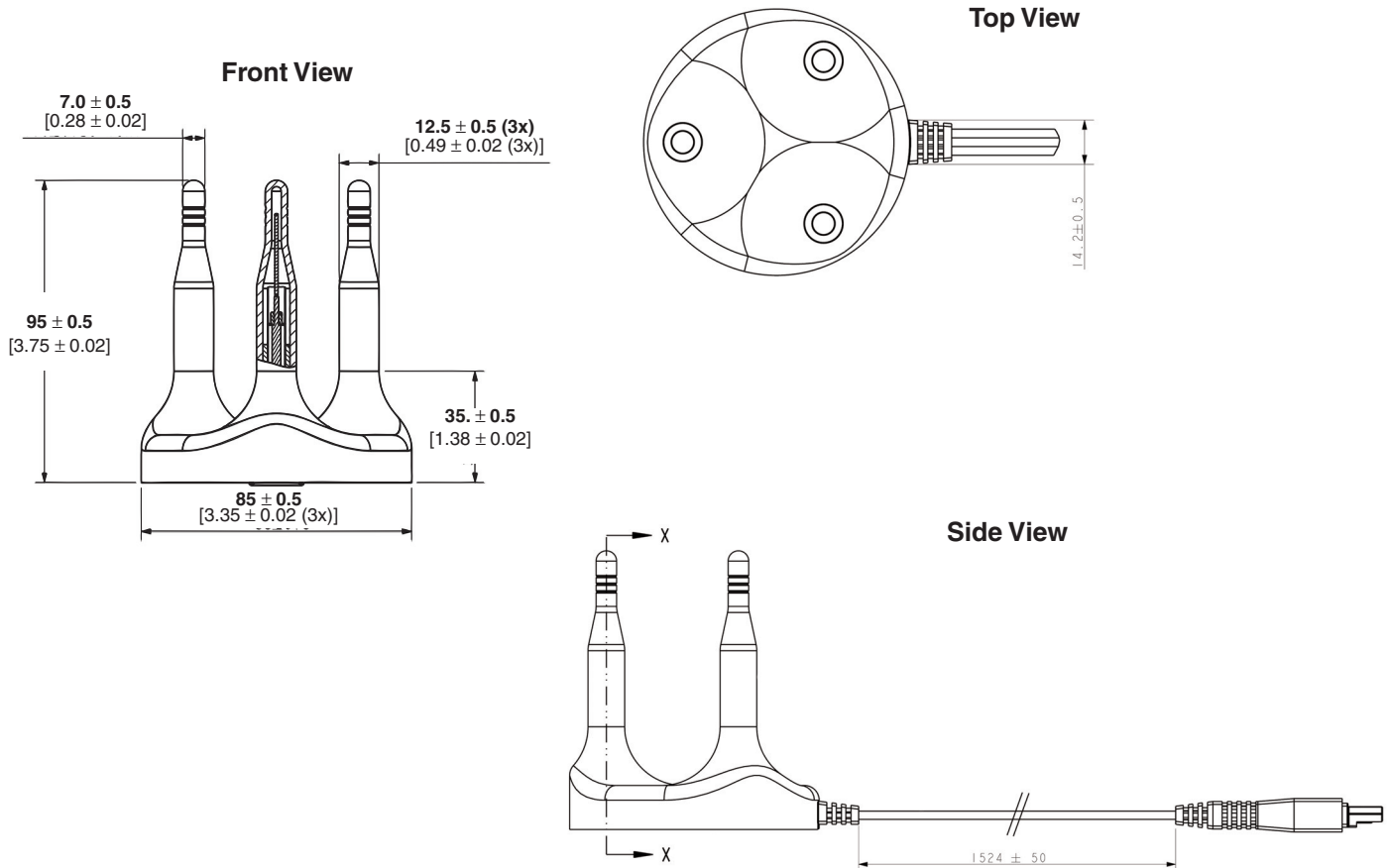

GLOBAL CONTACTS

Americas

Argentina — Buenos Aires
Phone: +54-11-4733-2200
Fax: +54-11-4733-2211

Brazil — São Paulo
Phone: +55-11-3611-1311
Fax: +55-11-3611-0397

Canada — Toronto
Phone: +905-475-6222
Fax: +905-474-5520
**Product Information Center:
(Technical Support)**
Phone: +905-470-4425
Fax: +905-474-5525

Colombia — Bogotá
Phone: +57-1-231-9398
Fax: +57-1-660-0206

Mexico — Mexico City
Phone: +52-55-1106-0800
Fax: +52-5-361-8545

United States — Harrisburg, PA
Phone: +717-564-0100
Fax: +717-986-7575
**Product Information Center:
(Technical Support)**
Phone: +800-522-6752
Fax: +717-986-7575

**For Latin/South American
Countries not shown**
Phone: +54-11-4733-2015
Fax: +54-11-4733-2083

Asia/Pacific

Australia — Sydney
Phone: +61-2-9554-2600
Fax: +61-2-9502-2556
**Product Information Center:
(Technical Support)**
Phone: +61-2-9840-8200
Fax: +61-2-9634-6188

India — Bangalore
Phone: +91-80-285-40800
Fax: +91-80-285-40820

Indonesia — Jakarta
Phone: +65-6482-0311
Fax: +65-6482-1012

Japan — Tokyo
Phone: +81-44-844-8111
Fax: +81-44-812-3207
Raychem & Identification Products
Phone: +81-44-844-8183
Fax: +81-44-844-8184
**Product Information Center:
(Technical Support)**
Phone: +81-44-844-8013
Fax: +81-44-812-3200

Korea — Seoul
Phone: +82-2-3415-4500
Fax: +82-2-3486-3810

Malaysia — Kuala Lumpur
Phone: +60-3-78053055
Fax: +60-3-78053066

New Zealand — Auckland
Phone: +64-9-634-4580
Fax: +64-9-634-4586

Philippines — Makati City
Phone: +632-848-0171
Fax: +632-867-8661

People's Republic of China
Hong Kong
Phone: +852-2735-1628
Fax: +852-2735-0243

Shanghai
Phone: +86-21-64857333/64850602
Fax: +86-21-64856222/54260190

Singapore — Singapore
Phone: +65-6482-0311
Fax: +65-6482-1012

Raychem Products
Phone: +65-4866-151
Fax: +65-6545-514
Identification Products
Phone: +65 (0) 6482-0311
Fax: +65 (0) 6481-5514

Taiwan — Taipei
Phone: +886-2-8768-2788
Fax: +886-2-8768-2268

Thailand — Bangkok
Phone: +66-2-955-0500
Fax: +66-2-955-0505

Vietnam and Indochina —
Ho Chi Minh City
Phone: +84-8 930-5546
Fax: +84-8 930-3443

Europe/Middle East/Africa

Austria — Vienna
Phone: +43-1 90 5 60-0
Fax: +43-1 90 5 60-1333

Belgium — Kessel-Lo
Phone: +32-16-35-23-00
Fax: +32-16-35-23-52

Bulgaria — Sofia
Phone: +359-2-971-2152
Fax: +359-2-971-2153

Czech Republic — Kurim
Phone: +420-5-41-162-111
Fax: +420-5-41-162-223

Denmark — Glostrup
Phone: +45-43-480-452
Fax: +45-43-441-414

Egypt — Cairo
Phone: +20-2-29 04 281
Fax: +20-2-41 92 334

Estonia — Tartu
Phone: +372-5138-274
Fax: +372-7400-779

Finland — Helsinki
Phone: +358-95-12-34-20
Fax: +358-95-12-34-250

France — Cergy-Pontoise
Phone: +33-1-3420-8888
Fax: +33-1-3420-8600
**Product Information
Center:
(Technical Support)**
Phone: +33-1-3420-8943
Fax: +33-1-3420-8623

Germany — Bensheim
Phone: +49-6251-133-0
Fax: +49-6251-133-1600
**Product Information
Center:
(Technical Support)**
Phone: +49-6251-133-1999
Fax: +49-6251-133-1988

Germany — Langen
Phone: +49-6103-709-0
Fax: +49-6103-709-1223

Germany — Speyer
Phone: +49-6232-30-0
Fax: +49-6232-30-2243

Germany - HTS Division —
Neunkirchen
Phone: +49-2247-305-0
Fax: +49-2247-305-122

Greece — Athens
Phone: +30-210-9370-396/397
Fax: +30-210-9370-655

Hungary — Budapest
Phone: +36-1-289-1000
Fax: +36-1-289-1010

Ireland — Dublin
Phone: +353-1-820-3000
Fax: +353-1-820-9790

Israel — Yokneam
Phone: +972-4-959-0508
Fax: +972-4-959-0506

Italy — Collegno (Torino)
Phone: +39-011-4012-111
Fax: +39-011-4031116

Lithuania — Vilnius
Phone: +370-5-2131-402
Fax: +370-5-2131-403

Netherlands —
Hertogenbosch
Phone: +31-73-624-62-46
Fax: +31-73-621-23-65
**Product Information
Center:
(Technical Support)**
Phone: +31-73-6246-999
Fax: +31-73-6246-998

Norway — Nesbru
Phone: +47-66-77-8886
Fax: +47-66-77-8855

Poland — Warsaw
Phone: +48-22-45-76-700
Fax: +48-22-45-76-720

Romania — Bucharest
Phone: +40-21-311-3479/3596
Fax: +40-21-312-0574

Russia — Moscow
Phone: +7-495-926-5506/07/08/09
Fax: +7-495-926-5505

Russia — St. Petersburg
Phone: +7-812-718-8192
Fax: +7-812-718-8193

Slovenia — Ljubljana
Phone: +386-1561-3270
Fax: +386-1561-3240

South Africa — Port Elizabeth
Phone: +2741-503-4500
Fax: +2741-581-0440

Spain — Barcelona
Phone: +34-93-291-0330
Fax: +34-93-201-7879

**Product Information
Center:
(Technical Support):**
Phone: +34-93-291-0330
Fax: +34-93-200-3779

Sweden — Upplands Väsby
Phone: +46-8-50-72-50-00
Fax: +46-8-50-72-50-01

Switzerland — Steinach
Phone: +41-71-447-0447
Fax: +41-71-447-0444

Turkey — Istanbul
Phone: +90-212-281-8181/8181/2/3
Fax: +90-212-281-8184

Ukraine — Kiev
Phone: +380-044-206-2265
Fax: +380-044-206-2264

United Kingdom — Swindon
Phone: +44-8706-080-208
Fax: +44-1793-572-516
**Product Information
Center:
(Technical Support)**
FreePhone GB: 0800-267-666
Phone: +44-8706-080-208
Fax: +44-208-420-8081

© Copyright 2007 by Tyco Electronics Corporation. All International Rights Reserved.

TE LOGO and TYCO ELECTRONICS are trademarks.

WIMAX is a trademark of WIMAX FORUM

WI-FI is a trademark of WI-FI ALLIANCE.

Other products, logos, and company names mentioned herein may be trademarks of their respective owners.

9-1773447-4 04/08

Компания «Океан Электроники» предлагает заключение долгосрочных отношений при поставках импортных электронных компонентов на взаимовыгодных условиях!

Наши преимущества:

- Поставка оригинальных импортных электронных компонентов напрямую с производств Америки, Европы и Азии, а так же с крупнейших складов мира;
- Широкая линейка поставок активных и пассивных импортных электронных компонентов (более 30 млн. наименований);
- Поставка сложных, дефицитных, либо снятых с производства позиций;
- Оперативные сроки поставки под заказ (от 5 рабочих дней);
- Экспресс доставка в любую точку России;
- Помощь Конструкторского Отдела и консультации квалифицированных инженеров;
- Техническая поддержка проекта, помощь в подборе аналогов, поставка прототипов;
- Поставка электронных компонентов под контролем ВП;
- Система менеджмента качества сертифицирована по Международному стандарту ISO 9001;
- При необходимости вся продукция военного и аэрокосмического назначения проходит испытания и сертификацию в лаборатории (по согласованию с заказчиком);
- Поставка специализированных компонентов военного и аэрокосмического уровня качества (Xilinx, Altera, Analog Devices, Intersil, Interpoint, Microsemi, Actel, Aeroflex, Peregrine, VPT, Syfer, Eurofarad, Texas Instruments, MS Kennedy, Miteq, Cobham, E2V, MA-COM, Hittite, Mini-Circuits, General Dynamics и др.);

Компания «Океан Электроники» является официальным дистрибьютором и эксклюзивным представителем в России одного из крупнейших производителей разъемов военного и аэрокосмического назначения «JONHON», а так же официальным дистрибьютором и эксклюзивным представителем в России производителя высокотехнологичных и надежных решений для передачи СВЧ сигналов «FORSTAR».



JONHON

«JONHON» (основан в 1970 г.)

Разъемы специального, военного и аэрокосмического назначения:

(Применяются в военной, авиационной, аэрокосмической, морской, железнодорожной, горно- и нефтедобывающей отраслях промышленности)

«FORSTAR» (основан в 1998 г.)

ВЧ соединители, коаксиальные кабели, кабельные сборки и микроволновые компоненты:

(Применяются в телекоммуникациях гражданского и специального назначения, в средствах связи, РЛС, а так же военной, авиационной и аэрокосмической отраслях промышленности).



Телефон: 8 (812) 309-75-97 (многоканальный)

Факс: 8 (812) 320-03-32

Электронная почта: ocean@oceanchips.ru

Web: <http://oceanchips.ru/>

Адрес: 198099, г. Санкт-Петербург, ул. Калинина, д. 2, корп. 4, лит. А