

3 V SILICON RFIC FREQUENCY UPCONVERTER

FEATURES

- **RECOMMENDED OPERATING FREQUENCY:**
 $f_{RFout} = 0.4 \text{ GHz to } 2.0 \text{ GHz}$
 $f_{Fin} = 100 \text{ MHz to } 400 \text{ MHz}$
- **SUPPLY VOLTAGE:**
 $V_{CC} = 2.7 \text{ to } 5.5 \text{ V}$
- **HIGH DENSITY SURFACE MOUNTING:**
 6 pin super mini mold package
- **LOW CARRIER LEAKAGE:**
 Due to double balanced mixer
- **BUILT-IN POWER SAVE FUNCTION**

DESCRIPTION

The UPC8106TB is a silicon RFIC designed as a frequency upconverter for cellular/cordless telephone transmitter stages and features improved intermodulation. This device is housed in a 6 pin super mini mold or SOT-363 package making it ideal for reducing system size. The UPC8106TB is manufactured using the 20 GHz ft NESAT™ III silicon bipolar process.

Stringent quality assurance and test procedures ensure the highest reliability and performance.

ELECTRICAL CHARACTERISTICS

($T_A = 25^\circ\text{C}$, $V_{CC} = V_{RFout} = 3 \text{ V}$, $f_{Fin} = 240 \text{ MHz}$, $PL_{Oin} = -5 \text{ dBm}$, $V_{PS} \geq 2.7 \text{ V}$ unless otherwise specified)

PART NUMBER PACKAGE OUTLINE			UPC8106TB S06		
SYMBOLS	PARAMETERS AND CONDITIONS	UNITS	MIN	TYP	MAX
I_{CC}	Circuit Current at $V_{PS} \geq 2.7 \text{ V}$ $V_{PS} = 0 \text{ V}$	mA μA	4.5	9	13.5 10
CG	Conversion Gain at $f_{RFout} = 0.9 \text{ GHz}$, $PI_{Fin} = -30 \text{ dBm}$ $f_{RFout} = 1.9 \text{ GHz}$, $PI_{Fin} = -30 \text{ dBm}$	dB dB	6 4	9 7	12 10
PSAT	Saturated Output Power at $f_{RFout} = 0.9 \text{ GHz}$, $PI_{Fin} = 0 \text{ dBm}$ $f_{RFout} = 1.9 \text{ GHz}$, $PI_{Fin} = 0 \text{ dBm}$	dBm dBm	-4 -6.5	-2 -4	
OIP ₃	Output Third-Order Intercept Point at $f_{Fin1} = 240.0 \text{ MHz}$ $f_{Fin2} = 240.4 \text{ MHz}$ $PI_{Fin} = -20 \text{ dBm}$	dBm dBm		+5.5 +2.0	
IM ₃	Third-Order Intermodulation Level at $f_{Fin1} = 240 \text{ MHz}$ $f_{Fin2} = 240.4 \text{ MHz}$ $PI_{Fin} = -20 \text{ dBm}$	dBc dBc		-31 -30	
NF	SSB Noise Figure, $f_{RFout} = 0.9 \text{ GHz}$	dB		8.5	
TPS(RISE)	Power Save Rise Time at V_{PS} : GND→VCC	μs		2.0	
TPS(FALL)	Power Save Fall Time at V_{PS} : VCC→GND	μs		2.0	

INTERNAL BLOCK DIAGRAM

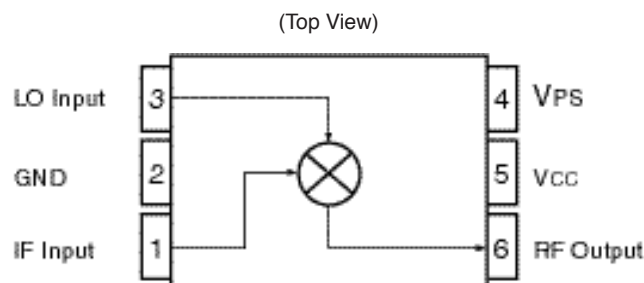

APPLICATION

- CELLULAR/CORDLESS TELEPHONE

ABSOLUTE MAXIMUM RATINGS¹ (T_A = 25°C)

SYMBOLS	PARAMETERS	UNITS	RATINGS
V _{CC}	Supply Voltage Pins 5 & 6	V	6.0
V _{PS}	Power Save Voltage	V	6.0
P _T	Total Power Dissipation ²	mW	200
T _{OP}	Operating Temperature	°C	-40 to +85
T _{STG}	Storage Temperature	°C	-55 to +150
P _{IN}	Input Power	dBm	+10

Notes:

1. Operation in excess of any one of these parameters may result in permanent damage.
2. Mounted on a 50 x 50 x 1.6 mm epoxy glass PWB (T_A = +85°C).

RECOMMENDED OPERATING CONDITIONS

SYMBOLS	PARAMETERS	UNITS	MIN	TYP	MAX
V _{CC}	Supply Voltage ¹	V	2.7	3.0	5.5
T _{OP}	Operating Temperature	°C	-40	+25	+85
P _{LO}	LO Input Level ²	dBm	-10	-5	0
f _{RFout}	RF Output Frequency ³	GHz	0.4		2.5
f _{IFin}	IF Input Frequency	MHz	100		400

Notes:

1. The same voltage should be supplied to pin 5 and 6.
2. Z_S = 50 Ω (without matching).
3. With external matching circuit.

TYPICAL PERFORMANCE CURVES (T_A = +25°C, V_{CC} = V_{RFout})

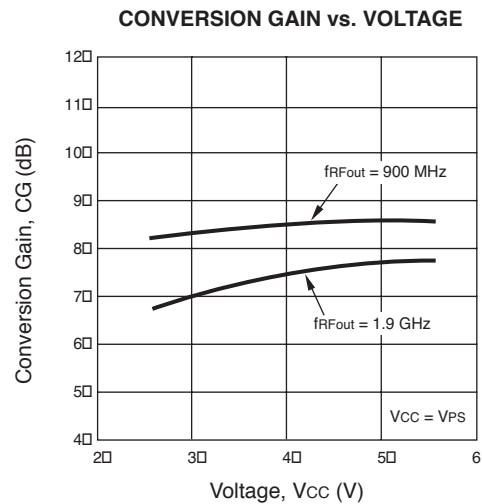
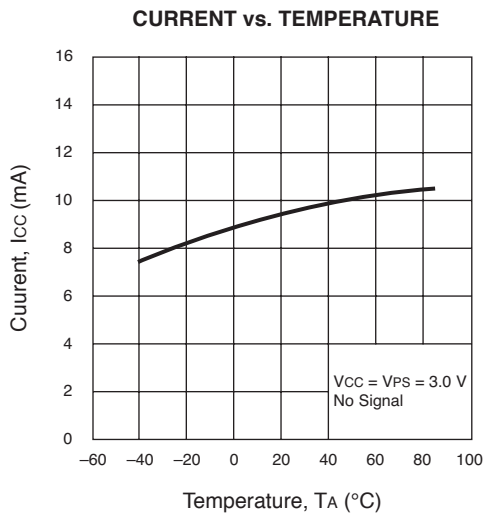
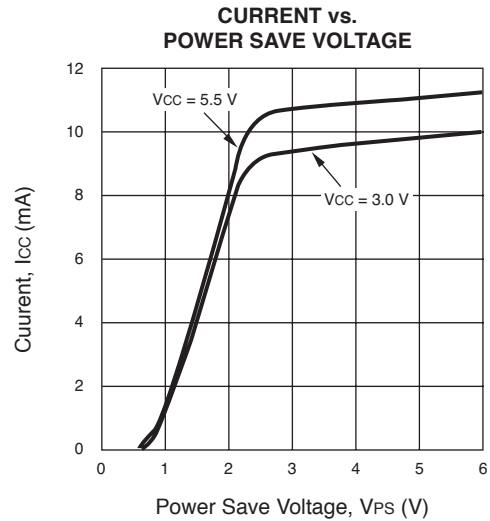
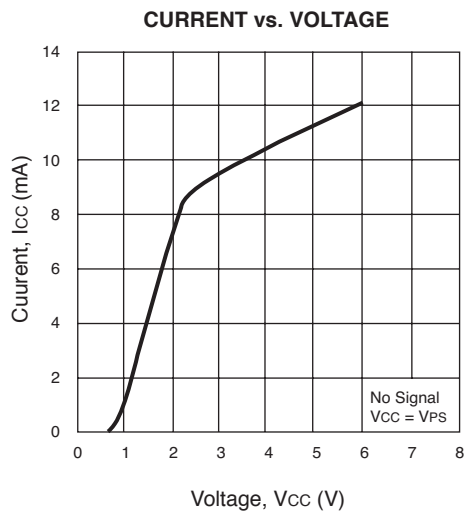

TYPICAL PERFORMANCE CURVES ($T_A = +25^\circ\text{C}$, $V_{CC} = V_{RFout}$)

CONVERSION GAIN vs. LOCAL INPUT LEVEL

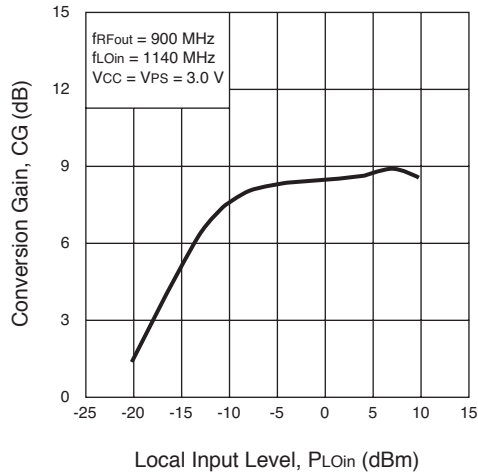

CONVERSION GAIN vs. LOCAL INPUT LEVEL

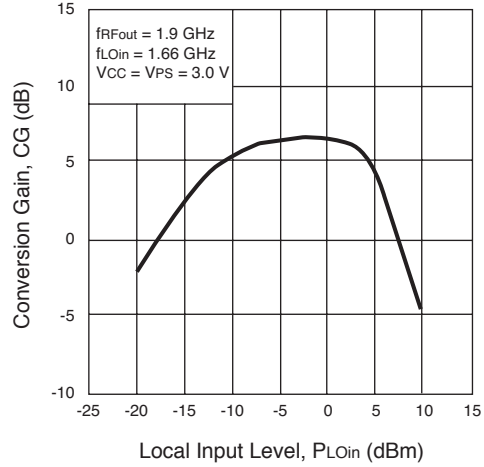

RF OUTPUT LEVEL AND IM3 vs. IF INPUT LEVEL

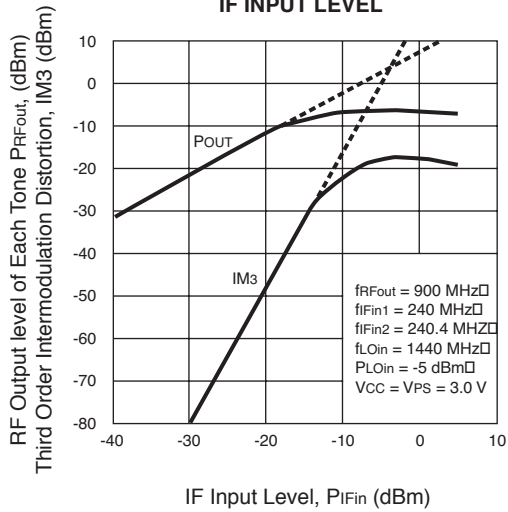

RF OUTPUT LEVEL AND IM3 vs. IF INPUT LEVEL

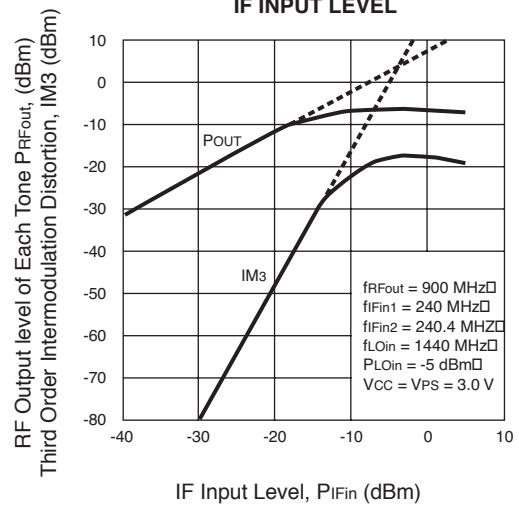

LOCAL LEAKAGE AT IF PIN vs. LOCAL INPUT FREQUENCY

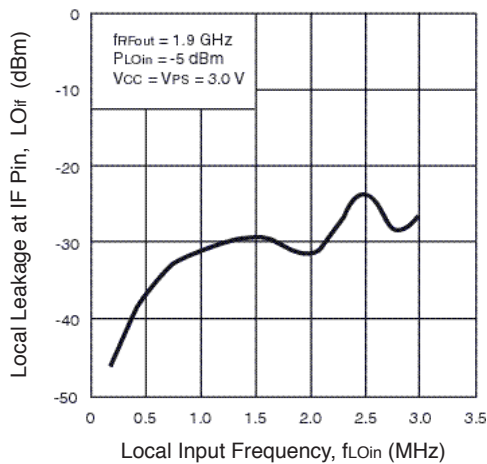

LOCAL LEAKAGE AT RF PIN vs. LOCAL INPUT FREQUENCY

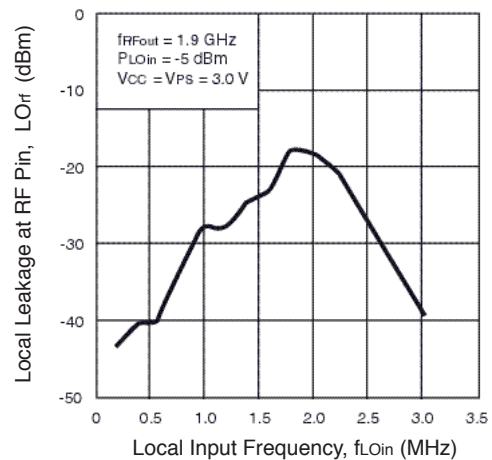

TYPICAL PERFORMANCE CURVES ($T_A = +25^\circ\text{C}$, $V_{CC} = V_{RFout}$)

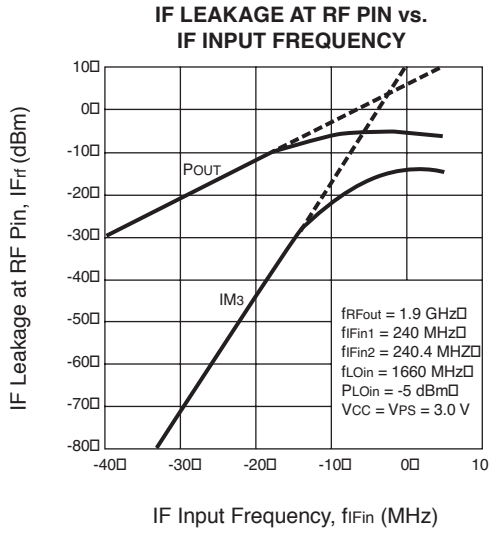

S-PARAMETERS FOR EACH PORT ($V_{CC} = V_{PS} = V_{RFout} = 3.0 \text{ V}$)

LO port

S_{11} Z
 REF 1.0 Units
 2 200.0 mUnits/
 ▽ 21.201 Ω -53.748 Ω
hp

MARKER 1
 1.15 GHz
 MARKER 2
 1.65 GHz

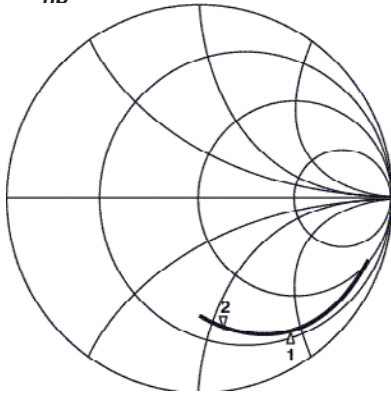

START 0.4 GHz

STOP 1.9 GHz

RF port

S_{22} Z
 REF 1.0 Units
 2 200.0 mUnits/
 ▽ 26.961 Ω -87.312 Ω
hp

MARKER 1
 900 MHz
 MARKER 2
 1.9 GHz

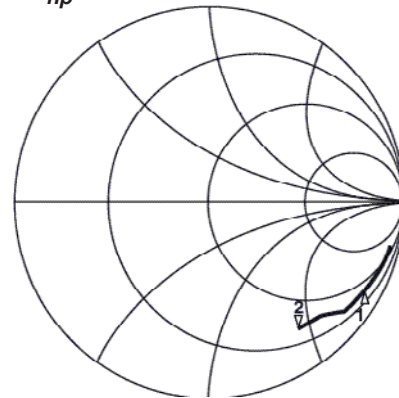

START 0.4 GHz

STOP 1.9 GHz

S-PARAMETERS FOR EACH PORT ($V_{CC} = V_{PS} = V_{RFout} = 3.0\text{ V}$)

IF port

S11 Z
 REF 1.0 Units
 1 200.0 mUnits/
 ∇ 194.16 Ω -579.53 Ω
hp

MARKER 1
 240 MHz

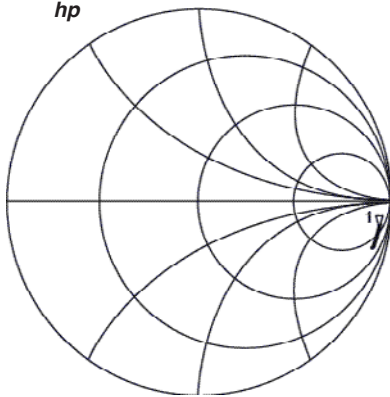

START 0.1 GHz STOP 0.4 GHz

S-PARAMETERS FOR MATCHED RF OUTPUT

($V_{CC} = V_{PS} = V_{RFout} = 3.0\text{ V}$) - with TEST CIRCUITS 1 and 2 - (S22 data is monitored at RF connector on board.)

900 MHz (LC-matched) in test circuit

S11 log MAG
 REF 0.0 dB
 1 10.0 dB/
 ∇ -19.567 dB
hp

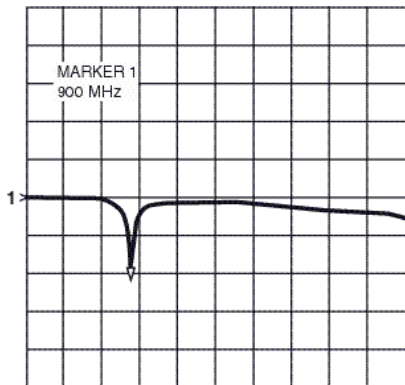

START 100 MHz STOP 3000 MHz

1.9 GHz (LC-matched) in test circuit

S22 log MAG
 REF 0.0 dB
 1 10.0 dB/
 ∇ -15.213 dB
hp

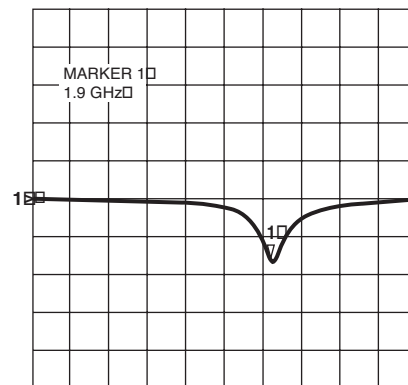

START 100 MHz STOP 3000 MHz

S22

REF 1.0 Units
 1 200.0 mUnits/
 ∇ 36.59 Ω 2.9355 Ω
hp

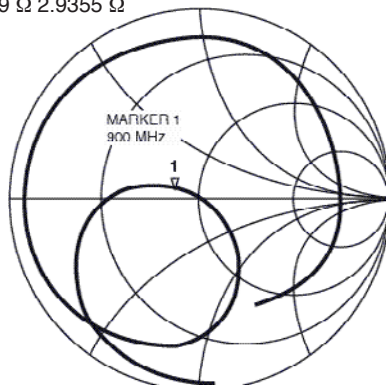

START 100 MHz STOP 3000 MHz

S22

REF 1.0 Units
 1 200.0 mUnits/
 ∇ 58.191 Ω -4.1191 Ω
hp

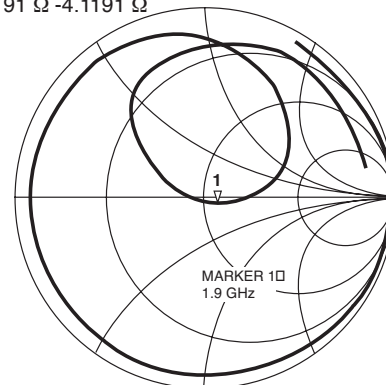

START 100 MHz STOP 3000 MHz

PIN FUNCTIONS

Pin No.	Symbol	Supply Voltage (V)	Pin ¹ Voltage (V)	Description	Equivalent Circuit						
1	IF Input	–	1.3	This pin is the IF input to the double balanced mixer. The input is a high impedance.							
2	GND	0	–	GND pin. Ground pattern on the board should be as wide as possible. Trace length should be kept as short as possible to minimize ground impedance.							
3	LOIN	–	2.4	LO input pin. Recommended input level is -10 to 0 dBm.							
5	Vcc	2.7 to 5.5	–	Supply voltage pin.							
6	RF Output	2.7 to 3.6	–	This pin is the RF output. This pin is designed as an open collector. Due to the high impedance output, this pin requires an external LC matching circuit.							
4	Vps	Vcc/GND	–	Power save control pin. Bias controls operation as follows: <table border="1" style="margin: 10px auto;"> <thead> <tr> <th>Pin Bias</th> <th>Control</th> </tr> </thead> <tbody> <tr> <td>Vcc</td> <td>ON</td> </tr> <tr> <td>GND</td> <td>Power Save</td> </tr> </tbody> </table>	Pin Bias	Control	Vcc	ON	GND	Power Save	
Pin Bias	Control										
Vcc	ON										
GND	Power Save										

Note:

1. Each pin voltage is measured with Vcc = Vps = VRFout = 3.0 V

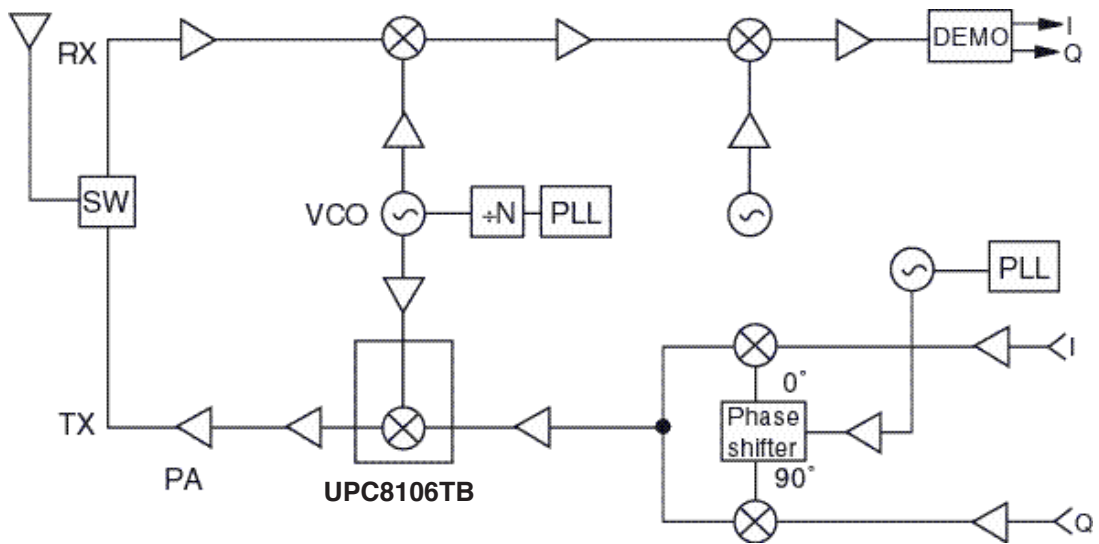
SYSTEM APPLICATION EXAMPLE**EXAMPLE OF DECT 900 MHz Cordless Phone**

TEST CIRCUIT 1 ($R_{FOUT} = 900 \text{ MHz}$)

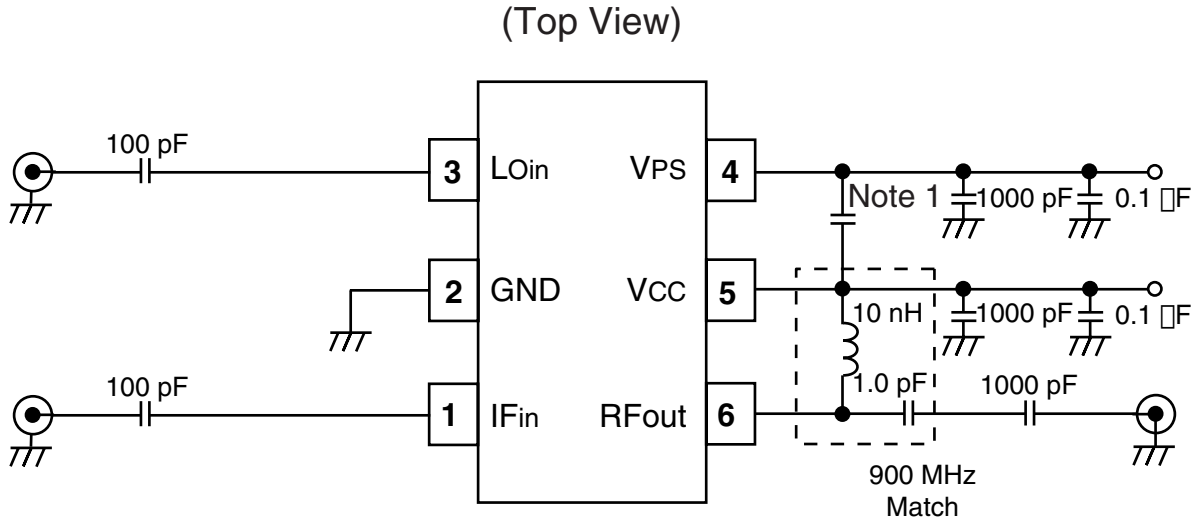

Note:

1. In case of unstable operation, connect 100 pF capacitor between pins 4 and 5.

TEST CIRCUIT 2 ($R_{FOUT} = 1.9 \text{ GHz}$)

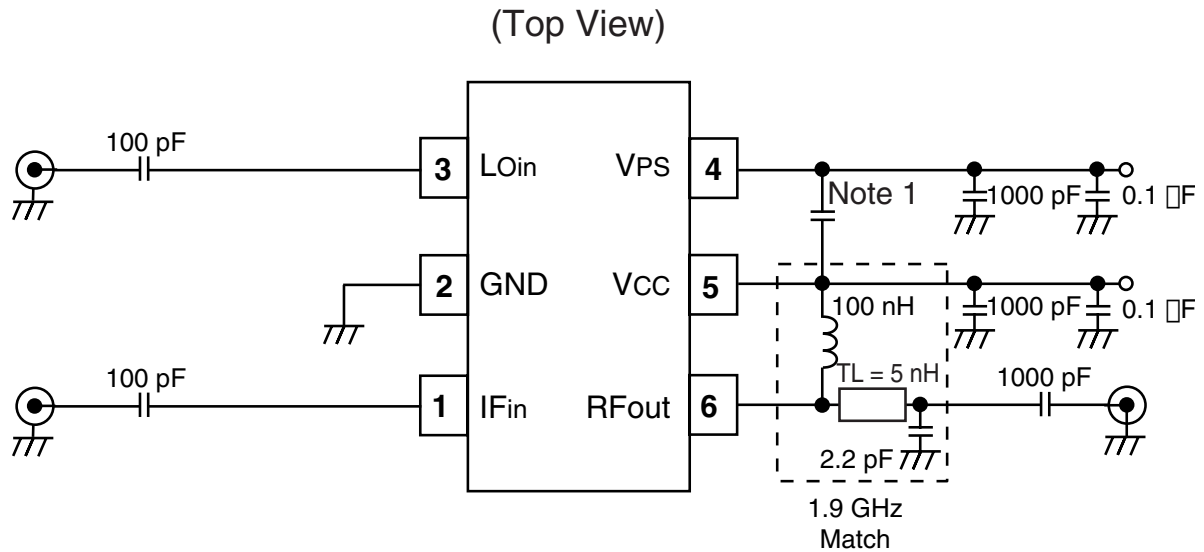

Note:

1. In case of unstable operation, connect 100 pF capacitor between pins 4 and 5.

OUTLINE DIMENSIONS (Units in mm)

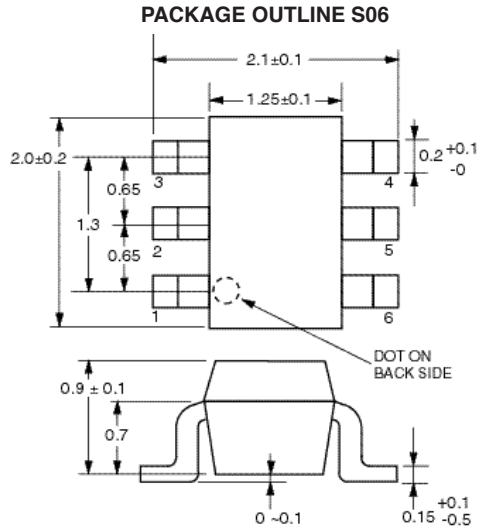

Note:
All dimensions are typical unless otherwise specified.

LEAD CONNECTIONS

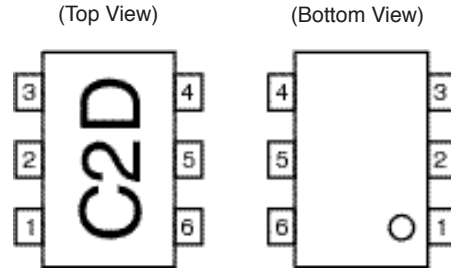

1. IF INPUT
2. GND
3. LO INPUT
4. POWER SAVE
5. V_{CC}
6. RF OUTPUT

ORDERING INFORMATION

PART NUMBER	QTY
UPC8106TB-E3-A	3K/Reel

Note:
Embossed Tape, 8 mm wide,
Pins 1, 2, and 3 face tape perforation side.

Компания «Океан Электроники» предлагает заключение долгосрочных отношений при поставках импортных электронных компонентов на взаимовыгодных условиях!

Наши преимущества:

- Поставка оригинальных импортных электронных компонентов напрямую с производств Америки, Европы и Азии, а так же с крупнейших складов мира;
- Широкая линейка поставок активных и пассивных импортных электронных компонентов (более 30 млн. наименований);
- Поставка сложных, дефицитных, либо снятых с производства позиций;
- Оперативные сроки поставки под заказ (от 5 рабочих дней);
- Экспресс доставка в любую точку России;
- Помощь Конструкторского Отдела и консультации квалифицированных инженеров;
- Техническая поддержка проекта, помощь в подборе аналогов, поставка прототипов;
- Поставка электронных компонентов под контролем ВП;
- Система менеджмента качества сертифицирована по Международному стандарту ISO 9001;
- При необходимости вся продукция военного и аэрокосмического назначения проходит испытания и сертификацию в лаборатории (по согласованию с заказчиком);
- Поставка специализированных компонентов военного и аэрокосмического уровня качества (Xilinx, Altera, Analog Devices, Intersil, Interpoint, Microsemi, Actel, Aeroflex, Peregrine, VPT, Syfer, Eurofarad, Texas Instruments, MS Kennedy, Miteq, Cobham, E2V, MA-COM, Hittite, Mini-Circuits, General Dynamics и др.);

Компания «Океан Электроники» является официальным дистрибьютором и эксклюзивным представителем в России одного из крупнейших производителей разъемов военного и аэрокосмического назначения «JONHON», а так же официальным дистрибьютором и эксклюзивным представителем в России производителя высокотехнологичных и надежных решений для передачи СВЧ сигналов «FORSTAR».



JONHON

«JONHON» (основан в 1970 г.)

Разъемы специального, военного и аэрокосмического назначения:

(Применяются в военной, авиационной, аэрокосмической, морской, железнодорожной, горно- и нефтедобывающей отраслях промышленности)

«FORSTAR» (основан в 1998 г.)

ВЧ соединители, коаксиальные кабели, кабельные сборки и микроволновые компоненты:

(Применяются в телекоммуникациях гражданского и специального назначения, в средствах связи, РЛС, а так же военной, авиационной и аэрокосмической отраслях промышленности).



Телефон: 8 (812) 309-75-97 (многоканальный)

Факс: 8 (812) 320-03-32

Электронная почта: ocean@oceanchips.ru

Web: <http://oceanchips.ru/>

Адрес: 198099, г. Санкт-Петербург, ул. Калинина, д. 2, корп. 4, лит. А