

Features and Benefits

- Absolute Rotary Position Sensor IC
- Simple & Robust Magnetic Design
- Triaxis® Hall Technology
- Programmable Angular Range up to 360 Degrees
- Programmable Linear Transfer Characteristic (up to 16 points)
- Selectable SENT (SAE-J2716) Protocol, Analog (Ratiometric), PWM
- 12 bit Angular Resolution - 10 bit Angular Thermal Accuracy
- 48 bit ID Number
- Single Die – SO8 Package RoHS Compliant
- Dual Die (Full Redundant) – TSSOP16 Package RoHS Compliant



Applications

- Absolute Rotary Position Sensor
- EMS Actuator (EGR, Manifold...)
- Throttle Position Sensor
- Non-Contacting Potentiometer

Ordering Code

Product Code	Temperature Code	Package Code	Option Code	Packing Form Code
MLX90324	L	DC	DBO-000	TU
MLX90324	L	DC	DBO-000	RE
MLX90324	L	GO	DBO-000	TU
MLX90324	L	GO	DBO-000	RE

Legend:

Temperature Code: L for Temperature Range -40°C to 150°C
 Package Code: DC for SOIC-8, GO for TSSOP-16
 Option Code: xxx-000: Standard version
 Packing Form: RE for Reel
 TU for Tube

Ordering example: MLX90324LDC-DBO-000-RE

1. Functional Diagram

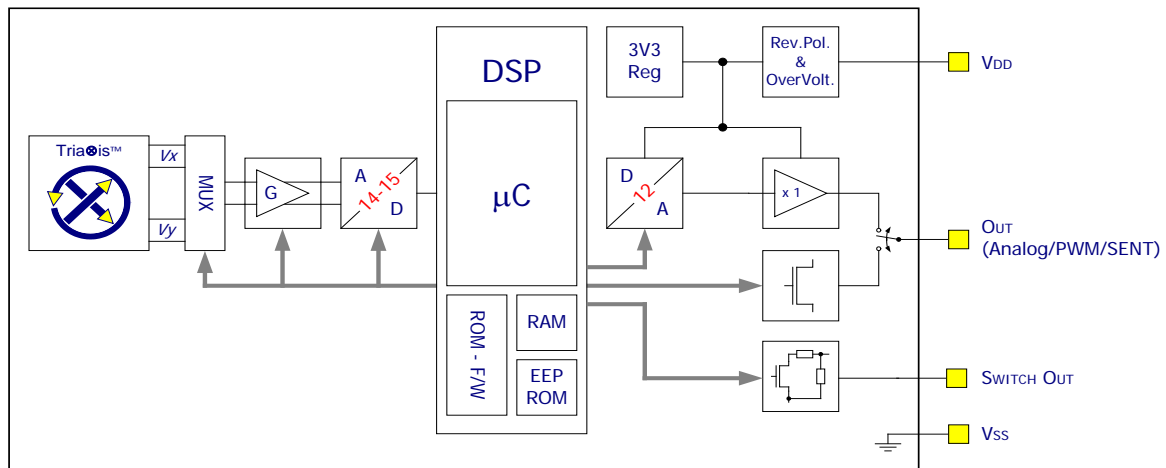

Figure 1 - Block Diagram (Analog, PWM & SENT)

2. Description

The MLX90324 is a monolithic sensor IC featuring the Triaxis® Hall technology. Conventional planar Hall technology is only sensitive to the flux density applied orthogonally to the IC surface. The Triaxis® Hall sensor is also sensitive to the flux density applied parallel to the IC surface. This is obtained through an Integrated Magneto-Concentrator (IMC®) which is deposited on the CMOS die (as an additional back-end step).

The MLX90324 is only sensitive to the flux density coplanar with the IC surface. This allows the MLX90324 with the correct magnetic circuit to decode the absolute rotary (angular) position from 0 to 360 Degrees. It enables the design of novel generation of non-contacting rotary position sensors that are frequently required for both automotive and industrial applications.

In combination with the appropriate signal processing, the magnetic flux density of a small magnet (diametral magnetization) rotating above the IC can be measured in a non-contacting way (Figure 2). The angular information is computed from both vectorial components of the flux density (i.e. B_x and B_y). MLX90324 produces an output signal proportional to the decoded angle. The output is selectable between Analog, PWM and SENT (SAE-J2716) Protocol.



Figure 2 - Typical application of MLX90324

The MLX90324 is similar to the MLX90316 in many ways but it is targeted for “Under-the-Hood” applications and the associated harsh hi-temperature environment. Amongst others, the hi-temperature performances and the SENT feature confirm this devotion.

TABLE of CONTENTS

FEATURES AND BENEFITS	1
APPLICATIONS.....	1
1. FUNCTIONAL DIAGRAM.....	2
2. DESCRIPTION.....	2
3. GLOSSARY OF TERMS – ABBREVIATIONS – ACRONYMS	5
4. PINOUT	5
5. ABSOLUTE MAXIMUM RATINGS	6
6. DETAILED DESCRIPTION.....	6
7. MLX90324 ELECTRICAL SPECIFICATION.....	9
8. MLX90324 ISOLATION SPECIFICATION	11
9. MLX90324 TIMING SPECIFICATION.....	11
10. MLX90324 ACCURACY SPECIFICATION	12
11. MLX90324 MAGNETIC SPECIFICATION	13
12. MLX90324 CPU & MEMORY SPECIFICATION	13
13. MLX90324 END-USER PROGRAMMABLE ITEMS.....	14
14. DESCRIPTION OF END-USER PROGRAMMABLE ITEMS.....	15
14.1. OUTPUT MODE.....	15
14.1.1. Analog Output Mode	15
14.1.2. PWM Output Mode.....	15
14.1.3. SENT Output Mode	16
14.1.4. Switch Out	16
14.2. OUTPUT TRANSFER CHARACTERISTIC.....	17
14.2.1. CLOCKWISE Parameter.....	17
14.2.2. Discontinuity Point (or Zero Degree Point).....	18
14.2.3. 3-Point LNR Parameters	18
14.2.4. 16-Point LNR Parameters	19
14.2.5. CLAMPING Parameters	19
14.2.6. DEADZONE Parameter.....	19
14.3. IDENTIFICATION	20
14.4. SENSOR FRONT-END	20
14.4.1. HIGHSPEED Parameter.....	20
14.4.2. AGC and Virtual Gain Parameters	20
14.4.3. GAINMIN and GAINMAX Parameters	21
14.5. FILTER	21
14.5.1. Hysteresis Filter	21
14.5.2. FIR Filters	21
14.5.3. IIR Filters	23
14.6. PROGRAMMABLE DIAGNOSTIC SETTINGS	24
14.6.1. RESONFAULT Parameter	24
14.6.2. EEHAMHOLE Parameter	24
14.7. LOCK.....	24
14.7.1. MLXLOCK Parameter	24
14.7.2. LOCK Parameter	24
15. MLX90324 SELF DIAGNOSTIC.....	25

16.	SENT (SAE-J2716) PROTOCOL	27
16.1.	INTRODUCTION	27
16.2.	SENT PROTOCOL DEFINITION	27
16.3.	SENT PROTOCOL IMPLEMENTATION	30
16.4.	USE OF THE MLX90324 SENT FEATURE.....	30
17.	RECOMMENDED APPLICATION DIAGRAMS.....	31
17.1.	ANALOG OUTPUT WIRING WITH THE MLX90324 IN SOIC PACKAGE.....	31
17.2.	ANALOG OUTPUT WIRING WITH THE MLX90324 IN TSSOP PACKAGE.....	32
17.3.	PWM LOW SIDE OUTPUT WIRING	32
17.4.	SENT OUTPUT WIRING WITH THE MLX90324 IN SOIC-8 PACKAGE.....	33
17.5.	SENT OUTPUT WIRING WITH THE MLX90324 IN TSSOP-16 PACKAGE.....	33
18.	STANDARD INFORMATION REGARDING MANUFACTURABILITY OF MELEXIS PRODUCTS	
	WITH DIFFERENT SOLDERING PROCESSES	34
19.	ESD PRECAUTIONS.....	34
20.	PACKAGE INFORMATION.....	35
20.1.	SOIC8 - PACKAGE DIMENSIONS	35
20.2.	SOIC8 - PINOUT AND MARKING	35
20.3.	SOIC8 - IMC POSITIONNING.....	35
20.4.	TSSOP16 - PACKAGE DIMENSIONS.....	37
20.5.	TSSOP16 - PINOUT AND MARKING	38
20.6.	TSSOP16 - IMC POSITIONNING.....	39
21.	DISCLAIMER.....	41

3. Glossary of Terms – Abbreviations – Acronyms

- Gauss (G), Tesla (T): Units for the magnetic flux density – 1 mT = 10 G
- TC: **T**emperature **C**oefficient (in ppm/Deg.C.)
- NC: **N**ot **C**onnected
- PWM: **P**ulse **W**idth **M**odulation
- SENT: **S**ingle **E**dge **N**ibble **T**ransmission (Protocol – SAE-J2716)
- Nibble: 4 bits
- Byte: 8 bits (= 2 nibbles)
- Word: 16 bits (= 2 bytes = 4 nibbles)
- %DC: **D**uty **C**ycle of the output signal i.e. $T_{ON} / (T_{ON} + T_{OFF})$
- ADC: **A**nalog-to-**D**igital **C**onverter
- DAC: **D**igital-to-**A**nalog **C**onverter
- LSB: **L**east **S**ignificant **B**it
- MSB: **M**ost **S**ignificant **B**it
- DNL: **D**ifferential **N**on-**L**inearity
- INL: **I**ntegral **N**on-**L**inearity
- ASP: **A**nalog **S**ignal **P**rocessing
- DSP: **D**igital **S**ignal **P**rocessing
- ATAN: trigonometric function: arctangent (or inverse tangent)
- IMC: **I**ntegrated **M**agneto-**C**oncentrator (IMC®)

4. Pinout

Pin #	SOIC-8	TSSOP-16
	Analog / PWM / SENT	Analog / PWM / SENT
1	VDD	VDIG ₁
2	Test 0	VSS ₁ (Ground ₁)
3	Switch Out	VDD ₁
4	Not Used	Test 0 ₁
5	Out	Switch Out ₂
6	Test 1	Not Used ₂
7	VDIG	Out ₂
8	VSS (Ground)	Test 1 ₂
9		VDIG ₂
10		VSS ₂ (Ground ₂)
11		VDD ₂
12		Test 0 ₂
13		Switch Out ₁
14		Not Used ₁
15		Out ₁
16		Test 1 ₁

For optimal EMC behavior, it is recommended to connect the unused pins (Not Used and Test) to the Ground (see section 16.1).

5. Absolute Maximum Ratings

Parameter	Value
Supply Voltage, VDD (overvoltage)	+ 20 V
Reverse Voltage Protection	– 10 V
Positive Output Voltage	+ 10 V + 14 V (200 s max – T _A = + 25°C)
Positive Output Voltage (Switch Out)	+ 10 V + 14 V (200 s max – T _A = + 25°C)
Output Current (I _{OUT})	± 30 mA
Reverse Output Voltage	– 0.3 V
Reverse Output Current	– 50 mA
Operating Ambient Temperature Range, T _A	– 40°C ... + 150°C
Storage Temperature Range, T _S	– 40°C ... + 150°C
Magnetic Flux Density	± 700 mT

Exceeding the absolute maximum ratings may cause permanent damage. Exposure to absolute-maximum-rated conditions for extended periods may affect device reliability.

6. Detailed Description

As described on the block diagram (Figure 1 and Figure 2), the magnetic flux density parallel to the IC surface is sensed through the Triaxis® sensor front-end. This front-end consists into two orthogonal pairs (for each of the two directions parallel with the IC surface i.e. X and Y) of conventional planar Hall plates (blue area on Figure 3) and an Integrated Magneto-Concentrator (IMC® yellow disk on Figure 3).



Figure 3 - Triaxis® sensor front-end (4 Hall plates + IMC® disk)

While a magnet (e.g. diametrically magnetized) rotates above the IC as described on Figure 2, the sensing stage provides two differential signals in quadrature (sine and cosine – Figure 4 and Figure 5)



Figure 4 – Magnetic Flux Density – $B_x \propto \cos(\alpha)$ & $B_y \propto \sin(\alpha)$

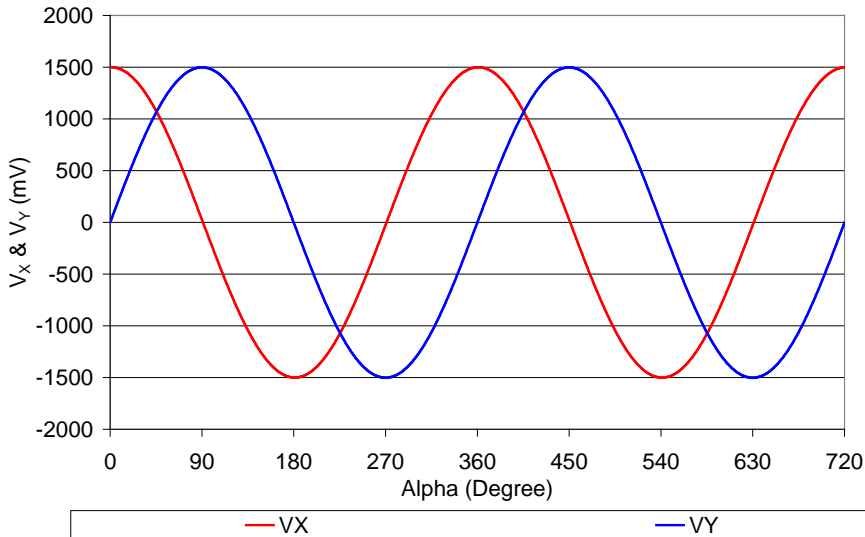

Figure 5 – Triaxis® sensor front-end – Output signals – $V_x \propto B_x \propto \cos(\alpha)$ & $V_y \propto B_y \propto \sin(\alpha)$

Those Hall signals are processed through a fully differential analog chain featuring the classic offset cancellation technique (Hall plate quadrature spinning and chopper-stabilized amplifier).

The conditioned analog signals are converted through an ADC (configurable – 14 or 15 bits) and provided to a DSP block for further processing. The DSP stage is based on a 16 bit RISC micro-controller whose primary function is the extraction of the angular position from the two raw signals (after so-called front-end compensation steps) through the following operation:

$$\alpha = ATAN\left(\frac{V_Y}{V_X}\right)$$

The DSP functionality is governed by the micro-code (firmware – F/W) of the micro-controller which is stored into the ROM (mask programmable). In addition to the “ATAN” function, the F/W controls the whole analog chain, the output transfer characteristic, the output protocol, the programming/calibration and also the self-diagnostic modes.

In the MLX90324, the “ATAN” function is computed via a look-up table (i.e. it is not obtained through a CoRDIC algorithm - **Coordinate Rotation Digital Computer** [i.e. iterative rectangular-to-polar transform]) Due to the fact that the “ATAN” operation is performed on the ratio “ V_Y/V_X ”, the angular information is intrinsically self-compensated vs. flux density variations (due to airgap change, thermal or ageing effects) affecting both signals. This feature allows therefore an improved thermal accuracy vs. rotary position sensor based on conventional linear Hall sensors.

In addition to the improved thermal accuracy, the realized rotary position sensor is capable of measuring a complete revolution (360 Degrees) and the linearity performances are excellent taking into account typical manufacturing tolerances (e.g. relative placement between the Hall IC and the magnet).

Once the angular information is computed (over 360 degrees), it is further conditioned (mapped) vs. the target transfer characteristic and it is provided at the output(s) as:

- an analog output level through a 12 bit DAC followed by a buffer
- a digital PWM signal with 12 bit depth (programmable frequency 100 Hz ... 1 kHz)
- a digital SENT Protocol Telegram

For instance, the analog output can be programmed for offset, gain and clamping to meet any rotary position sensor output transfer characteristic:

$$\begin{array}{ll} V_{out}(\alpha) = \text{ClampLo} & \text{for } \alpha \leq \alpha_{min} \\ V_{out}(\alpha) = V_{offset} + \text{Gain} \times \alpha & \text{for } \alpha_{min} \leq \alpha \leq \alpha_{max} \\ V_{out}(\alpha) = \text{ClampHi} & \text{for } \alpha \geq \alpha_{max} \end{array}$$

where V_{offset} , Gain, ClampLo and ClampHi are the main adjustable parameters for the end-user.

The linear part of the transfer curve can be adjusted through either a 2 point or a 3 point calibration depending on the linearity requirement.

A digital output is also available and used as a programmable angular switch.

The calibration parameters are stored in EEPROM featuring a Hamming Error Correction Coding (ECC).

The programming steps do not require any dedicated pins. The operation is done using the supply and output nodes of the IC. The programming of the MLX90324 is handled at both engineering lab and production line levels by the Melexis Programming Unit PTC-04 with the dedicated MLX90316/90324 daughterboard and software tools (DLL – User Interface).

7. MLX90324 Electrical Specification

DC Operating Parameters at VDD = 5V (unless otherwise specified) and for TA as specified by the Temperature suffix (L).

Parameter	Symbol	Test Conditions	Min	Typ	Max	Units
Nominal Supply Voltage	VDD		4.5	5	5.5	V
Supply Current ⁽¹⁾	Idd	Slow mode ⁽²⁾		7	10	mA
		Medium mode ⁽²⁾		10.5	13	mA
		Fast mode ⁽²⁾		12.5	15	mA
POR Level	VDD POR	Supply Under Voltage	2	2.7	3	V
Output Current	Iout	Analog Output mode	-8		8	mA
		PWM, SENT Output mode	-20		20	mA
Output Short Circuit Current	Ishort	Vout = 0 V		12	15	mA
		Vout = 5 V		12	15	mA
		Vout = 14 V (TA = 25°C)		24	45	mA
Output Load	RL	Pull-down to Ground	1	10	∞ ⁽⁴⁾	kΩ
		Pull-up to 5V ⁽³⁾	1	10	∞ ⁽⁴⁾	kΩ
Analog Saturation Output Level	Vsat_lo	Pull-up load RL ≥ 10 kΩ			3	%VDD
	Vsat_hi	Pull-down load RL ≥ 10 kΩ	96			%VDD
Digital Saturation Output Level	VsatD_lo	Pull-up Low Side RL ≥ 10 kΩ Push-Pull (IOUT = -20mV)			1.5	%VDD
	VsatD_hi	Push-Pull (IOUT = 20mV)	97			%VDD
Active Diagnostic Output Level	Diag_lo	Pull-down load RL ≥ 10 kΩ Pull-up load RL ≥ 10 kΩ			1 1.5	%VDD
	Diag_hi	Pull-down load RL ≥ 10 kΩ Pull-up load RL ≥ 10 kΩ	97 98			%VDD
Passive Diagnostic Output Level (Broken Track Diagnostic) ⁽⁵⁾	BVSSPD	Broken VSS & Pull-down load RL ≤ 10 kΩ			4	%VDD
	BVSSPU	Broken VSS & Pull-up load RL ≥ 1kΩ	99	100		%VDD
	BVDDPD	Broken VDD & Pull-down load RL ≥ 1kΩ		0	1	%VDD
	BVDDPU	Broken VDD & Pull-up load RL ≤ 10kΩ to 5V	96			%VDD
<i>MLX 90324 Electrical Specification continues...</i>						
<i>...MLX 90324 Electrical Specification</i>						

¹ For the dual version, the supply current is multiplied by 2

² See section 14.4.1 for details concerning Slow and Fast mode

³ Applicable for output in Analog, PWM and SENT (Open-Drain) modes

⁴ RL < ∞ for output in PWM mode

⁵ For detailed information, see also section 15

Clamped Output Level	Clamp_lo	Programmable	0		100	%VDD ⁽⁶⁾
	Clamp_hi	Programmable	0		100	%VDD ⁽⁶⁾
Switch Out ⁽⁷⁾	Sw_lo	Pull-up Load 1.5k to 5V	0.55		1.1	V
	Sw_hi	Pull-up Load 1.5k to 5V	3.65		4.35	V

As an illustration of the previous table, the MLX90324 fits the typical classification of the output span described on the Figure 6.



Figure 6 - Output Span Classification

⁶ Clamping levels need to be considered vs the saturation of the output stage (see Vsat_lo and Vsat_hi)

⁷ See section 14.1.4 for the application diagram

8. MLX90324 Isolation Specification

DC Operating Parameters at $V_{DD} = 5V$ (unless otherwise specified) and for T_A as specified by the Temperature suffix (L). Only valid for the package code GO i.e. dual die version.

Parameter	Symbol	Test Conditions	Min	Typ	Max	Units
Isolation Resistance		Between 2 dies	4			MΩ

9. MLX90324 Timing Specification

DC Operating Parameters at $V_{DD} = 5V$ (unless otherwise specified) and for T_A as specified by the Temperature suffix (L).

Parameter	Symbol	Test Conditions	Min	Typ	Max	Units
Main Clock Frequency	Ck	Slow mode ⁽⁸⁾		5.5		MHz
		Medium mode ⁽⁸⁾		10		MHz
		Fast mode ⁽⁸⁾		16		MHz
Sampling Rate		Slow mode ⁽⁸⁾		600		μs
		Medium mode ⁽⁸⁾		400		μs
		Fast mode ⁽⁸⁾		330		μs
Step Response Time	Ts	Slow mode ⁽⁸⁾ , Filter=5 ⁽⁹⁾			4	ms
		Medium mode ⁽⁸⁾ , Filter=0 ⁽⁹⁾			1200	μs
		Fast mode ⁽⁸⁾ , Filter=0 ⁽⁹⁾	660		1000	μs
Watchdog	Wd	See Section 15			5	ms
Start-up Cycle	Tsu	Slow, Medium and Fast mode ⁽⁸⁾			15	ms
Analog Output Slew Rate		$C_{OUT} = 40 - 100$ nF				
		Falling Edge		9		V/ms
		Rising Edge		18		V/ms
PWM Frequency	F _{PWM}	PWM Output Enabled	100		1000	Hz
Digital Output Rise Time		Mode 5 – 10nF, R _L = 5.6 kΩ		120		μs
		Mode 6 – 10nF, R _L = 5.6 kΩ		2.6		μs
		Mode 7 – 10nF, R _L = 5.6 kΩ		2.6		μs
Digital Output Fall Time		Mode 5 – 10nF, R _L = 5.6 kΩ		800		ns
		Mode 6 – 10nF, R _L = 5.6 kΩ		120		μs
		Mode 7 – 10nF, R _L = 5.6 kΩ		820		ns

⁸ See section 14.4.1 for details concerning Slow, Medium and Fast mode

⁹ See section 14.5 for details concerning Filter parameter

10. MLX90324 Accuracy Specification

DC Operating Parameters at VDD = 5V (unless otherwise specified) and for T_A as specified by the Temperature suffix (L).

Parameter	Symbol	Test Conditions	Min	Typ	Max	Units
ADC Resolution on the raw signals sine and cosine	R _{ADC}	Slow Mode ⁽¹⁰⁾ Medium Mode ⁽¹⁰⁾ Fast Mode ⁽¹⁰⁾		15 14 14		bits bits bits
Thermal Offset Drift #1 ⁽¹¹⁾		Thermal Offset Drift at the DSP input (excl. DAC and output stage)	-60		+60	LSB ₁₅
Thermal Offset Drift #2 (to be considered only for the analog output mode)		Thermal Offset Drift of the DAC and Output Stage	-0.4		+0.4	%VDD
Thermal Drift of Sensitivity Mismatch ⁽¹²⁾			-0.5		+0.5	%
Intrinsic Linearity Error ⁽¹³⁾	Le	T _A = 25°C	-1		1	Deg
Analog Output Resolution	R _{DAC}	12 bits DAC (Theoretical – Noise free) INL DNL	-4 0.05	0.025 1	+4 2	%VDD/LSB LSB LSB
Output stage Noise		Clamped Output		0.05		%VDD
Noise pk-pk ⁽¹⁴⁾		VG = 9, Slow mode, Filter=5 VG = 9, Fast mode, Filter=0		0.03 0.1	0.06 0.2	Deg Deg
Ratiometry Error			-0.1	0	0.1	%VDD
PWM Output Resolution	R _{PWM}	12 bits (Theoretical – Jitter free)		0.025		%DC/LSB
PWM Jitter ⁽¹⁵⁾	J _{PWM}	VG = 6, F _{PWM} = 250 Hz – 800Hz			0.2	%DC

¹⁰ 15 bits corresponds to 14 bits + sign and 14 bits corresponds to 13 bits + sign. After angular calculation, this corresponds to 0.005Deg/LSB₁₅ in Low Speed Mode and 0.01Deg/LSB₁₄ in High Speed.

¹¹ For instance, Thermal Offset Drift #1 equal ± 60LSB₁₅ yields to max. ± 0.3 Deg. angular error for the computed angular information (output of the DSP). See Front End Application Note for more details. This is only valid if automatic gain is set (See Section 14.4.2)

¹² For instance, Thermal Drift of Sensitivity Mismatch equal ± 0.4% yields to max. ± 0.1 Deg. angular error for the computed angular information (output of the DSP). See Front End Application Note for more details.

¹³ The Intrinsic Linearity Error refers to the IC itself (offset, sensitivity mismatch, orthogonality) taking into account an ideal rotating field. Once associated to a practical magnetic construction and the associated mechanical and magnetic tolerances, the output linearity error increases. However, it can be improved with the multi point end-user calibration that is available on the MLX90324.

¹⁴ The application diagram used is described in the recommended wiring. For detailed information, refer to section Filter in application mode (Section 14.5).

¹⁵ Jitter is defined by ± 3 σ for 1000 successive acquisitions and the slope of the transfer curve is 100%DC/360 Deg.

11. MLX90324 Magnetic Specification

DC Operating Parameters at $V_{DD} = 5V$ (unless otherwise specified) and for T_A as specified by the Temperature suffix (L).

Parameter	Symbol	Test Conditions	Min	Typ	Max	Units
Magnetic Flux Density	B		20	50	70 ⁽¹⁶⁾	mT
Magnet Temperature Coefficient	TCm		-2400		0	ppm/°C

12. MLX90324 CPU & Memory Specification

The DSP is based on a 16 bit RISC μ Controller. This CPU provides 2.5 Mips while running at 10 MHz.

Parameter	Symbol	Test Conditions	Min	Typ	Max	Units
ROM				10		kB
RAM				256		B
EEPROM				128		B

¹⁶ Above 70 mT, the IMC starts saturating yielding to an increase of the linearity error.

13. MLX90324 End-User Programmable Items

Parameter	Comments	Default Values	
		-	# bit
Output Mode	Define the output stage mode	2	3
PWMPOL1	PWM Polarity	0	1
PWM_Freq	PWM Frequency	1000h	16
CLOCKWISE		0	1
DP	Discontinuity Point	0h	15
16POINTS	Selection of correction method 3 or 16 pts	0	1
LNR_S0	Initial Slope	0h	16
LNR_A_X	AX Coordinate	8000h	16
LNR_A_Y	AY Coordinate	0h	16
LNR_A_S	AS Coordinate	0h	16
LNR_B_X	BX Coordinate	FFFFh	16
LNR_B_Y	BY Coordinate	0h	16
LNR_B_S	BS Coordinate	0h	16
LNR_C_X	CX Coordinate	FFFFh	16
LNR_C_Y	CY Coordinate	FFFFh	16
LNR_C_S	CS Coordinate	0h	16
LNR_Y0	16pts – Y-coordinate point 0	N/A	16
LNR_Y1	16pts – Y-coordinate point 1	N/A	16
...
LNR_Y16	16pts – Y-coordinate point 16	N/A	16
CLAMP_HIGH	Clamping High	8%	16
CLAMP_LOW	Clamping Low	8%	16
KD	Switch Out	FFFFh	16
KDHYST	Hysteresis on the Switch Out	0	8
DEADZONE		0	8
FHYST		4	8
MELEXISID1		MLX	16
MELEXISID2		MLX	16
MELEXISID3		MLX	16
CUSTOMERID1		1	8
CUSTOMERID2		17h	16
CUSTOMERID3		MLX	16
HIGHSPEED		0	1
MEDIUMSPEED		0	1
ROLLCNT	Rolling Counter (SENT)	0	1
FSWAP		0	1
FILTER		5	8
AGC	Automatic Gain Selection	0	1
GAINMIN		11	4
GAINMAX		41 ⁽¹⁷⁾	4
EEHAMHOLE		3131h	16
RESONFAULT		0	2
SENT		0	1
MLXLOCK		19h	1
LOCK		0	1

¹⁷ CodeGAINMAX programmed to value F0h (240d), clamped to maximum gain value 41d by FW

14. Description of End-User Programmable Items

14.1. Output Mode

The MLX90324 output type is defined by the Output Mode parameter.

Parameter	Value	Description
Analog Output Mode	2	Analog Rail-to-Rail
PWM Output Mode	5	Low Side (NMOS)
	6	High Side (PMOS)
	7	Push-Pull
SENT Output Mode	N/A	Push-Pull

14.1.1. Analog Output Mode

The Analog Output Mode is a rail-to-rail and ratiometric output with a push-pull output stage configuration allows the use of a pull-up or pull-down resistor.

14.1.2. PWM Output Mode

If one of the PWM Output modes is selected, the output signal is a digital signal with Pulse Width Modulation (PWM).

In mode 5, the output stage is an open drain NMOS transistor (low side), to be used with a pull-up resistor to VDD.

In mode 6, the output stage is an open drain PMOS transistor (high side), to be used with a pull-down resistor.

In mode 7, the output stage is a push-pull stage.

The PWM polarity is selected by the PWMPOL1 parameter:

- PWMPOL1 = 0 for a low level at 100%
- PWMPOL1 = 1 for a high level at 100%

The PWM frequency is selected by the PWM_Freq parameter.

PWM Frequency Code				
Oscillator Mode	Pulse-Width Modulation Frequency (Hz)			
	100	200	500	1000
Low Speed	27500	13750	6875	3435
Medium Speed	50000	25000	10000	5000
High Speed	-	40000	16000	8000

For instance, in Low Speed Mode, set PWM_Freq = 6875 (decimal) to set the PWM frequency at 500Hz.

14.1.3. SENT Output Mode

The MLX90324 features a digital SENT (SAE-J2716) Protocol Mode. The rolling counter can be enabled/disabled by the ROLLCNT bit:

- ROLLCNT = 0 to enable the rolling counter
- ROLLCNT = 1 to disable the rolling counter

See the dedicated SENT Protocol section for a full description (Section 16).

14.1.4. Switch Out

Parameter	Value	Unit
KD	0...359.9999	deg
KDHYST	0 ... 1.4	deg

The switch is activated (Sw_lo) when the digital angle is greater than the value stored in the KD parameter. This angle refers to the internal angular reference linked to the parameter DP and not to the absolute physical 0° angle.

The KDHYST defines the hysteresis amplitude around the Switch point. The switch is actually activated if the digital angle is greater than KD+KDHYST. It is deactivated if the digital angle is less than KD-KDHYST.

The mandatory application diagram to use this feature is depicted in the Figure 7. See section 7 for the electrical characteristic.

If the Switch feature is not used in the application, the output pin needs to be connected to the ground.

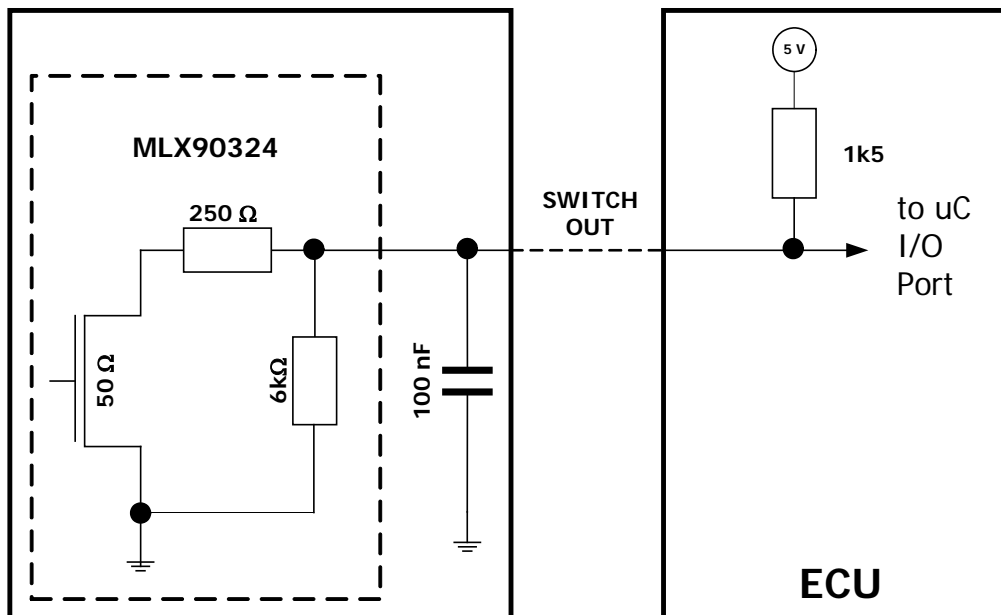

Figure 7 – Application Diagram for the Switch Out

14.2. Output Transfer Characteristic

There are 2 different possibilities to define the transfer function (LNR):

- With 3 points (defined on X and Y coordinates) and 4 slopes
- With 16 points equidistant where only Y coordinates are defined.

Parameter	LNR type	Value	Unit
CLOCKWISE	Both	0 → CCW 1 → CW	
DP	Both	0 ... 359.9999	deg
LNR_A_X LNR_B_X LNR_C_X	Only 3 pts	0 ... 359.9999	deg
LNR_A_Y LNR_B_Y LNR_C_Y	Only 3 pts	0 ... 100	%
LNR_S0	Only 3 pts	0 ... 17	%/deg
LNR_A_S LNR_B_S LNR_C_S	Only 3 pts	-17 ... 0 ... 17	%/deg
LNR_Y0 LNR_Y1 ... LNR_Y16	Only 16 pts	0 ... 100	%
CLAMP_LOW	Both	0 ... 100	%
CLAMP_HIGH	Both	0 ... 100	%

14.2.1. CLOCKWISE Parameter

The CLOCKWISE parameter defines the magnet rotation direction.

- CCW is defined by the 1-4-5-8 pin order direction for the SOIC8 package and 1-8-9-16 pin order direction for the TSSOP16 package.
- CW is defined by the reverse direction: 8-5-4-1 pin order direction for the SOIC8 and 16-9-8-1 pin order direction for the TSSOP16 package.

Refer to the drawing in the IMC positioning sections (Section 20.3 and 20.6).

14.2.2. Discontinuity Point (or Zero Degree Point)

The Discontinuity Point defines the 0° point on the circle. The discontinuity point places the origin at any location of the trigonometric circle. The DP is used as reference for all the angular measurements.

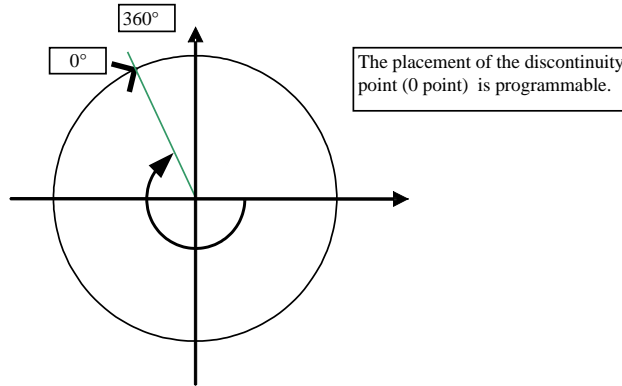

Figure 8 - Discontinuity Point Positioning

14.2.3. 3-Point LNR Parameters

The LNR parameters, together with the clamping values, fully define the relation (the transfer function) between the digital angle and the output signal.

The shape of the MLX90324 transfer function from the digital angle value to the output voltage is described by the drawing below. Six segments can be programmed but the clamping levels are necessarily flat.

Two, three, or even five calibration points are then available, reducing the overall non-linearity of the IC by almost an order of magnitude each time. Three or five point calibration will be preferred by customers looking for excellent non-linearity figures. Two-point calibrations will be preferred by customers looking for a cheaper calibration set-up and shorter calibration time.



14.2.4. 16-Point LNR Parameters

The LNR parameters, together with the clamping values, fully define the relation (the transfer function) between the digital angle and the output signal. The shape of the MLX90324 transfer function from the digital angle value to the output voltage is described by the drawing below.

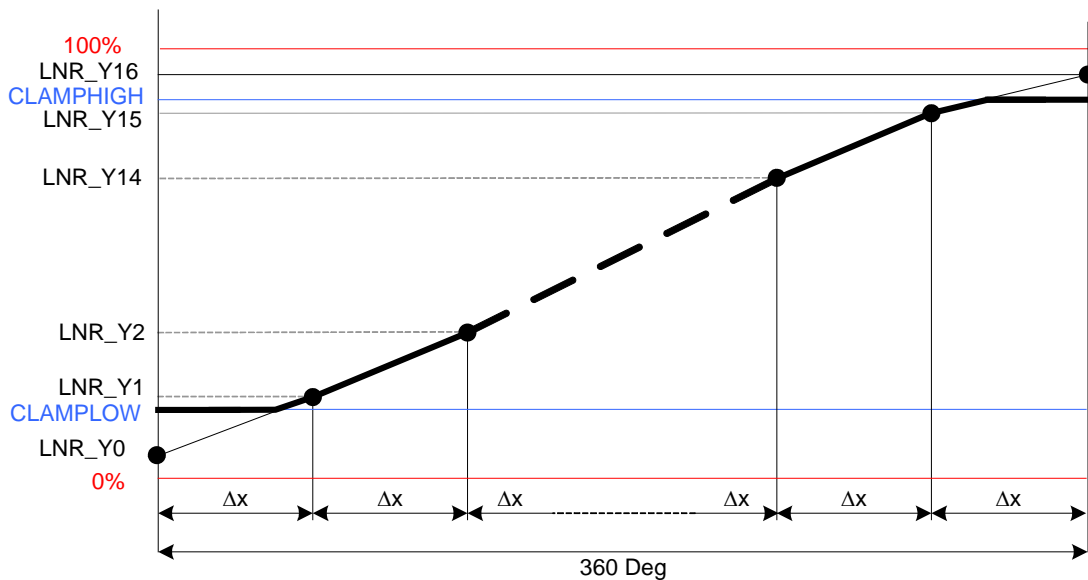

Figure 9 – 16-Point Calibration

14.2.5. CLAMPING Parameters

The clamping levels are two independent values to limit the output voltage range. The CLAMP_LOW parameter adjusts the minimum output voltage level. The CLAMP_HIGH parameter sets the maximum output voltage level. Both parameters have 16 bits of adjustment with a resolution of approximately 0.076 mV.

14.2.6. DEADZONE Parameter

The dead zone is defined as the angle window between 0 and 359.9999. When the digital angle lies in this zone, the IC is in fault mode (RESONFAULT must be set to “1” – See 14.6.1).

14.3. Identification

Parameter	Value	Unit
MELEXSID1	0 ... 65535	
MELEXSID2	0 ... 65535	
MELEXSID3	0 ... 65535	
CUSTOMERID1	0 ... 65535	
CUSTOMERID2	0 ... 65535	
CUSTOMERID3	0 ... 65535	

Identification number: 40 bits freely useable by Customer for traceability purpose.

14.4. Sensor Front-End

Parameter	Value	Unit
HIGHSPEED	0 = Slow mode 1 = Fast mode	
MEDIUMSPEED	0 = Slow mode 1 = Medium mode	
AGC	0 = disable 1 = enable	
VirtualGain	0 ... 41	
GAINMIN	0 ... 41	
GAINMAX	0 ... 41	

14.4.1. HIGHSPEED Parameter

The HIGHSPEED and MEDIUMSPEED parameters define the main frequency for the DSP.

- HIGHSPEED = 0, MEDIUMSPEED = 0 select the Slow mode with a 5.5 MHz master clock.
- HIGHSPEED = 0, MEDIUMSPEED = 1 select the Medium mode with a 10 MHz master clock.
- HIGHSPEED = 1, MEDIUMSPEED = 0 select the Fast mode with a 16 MHz master clock.

For better noise performance, the Slow Mode must be enabled.

14.4.2. AGC and Virtual Gain Parameters

The AGC parameter enables the automatic gain control of the analog chain. The AGC loop is based on $(V_x)^2 + (V_y)^2 = (\text{Amplitude})^2 = (\text{Radius})^2$

and it targets an amplitude of 90% of the ADC input span.

If AGC is “0”, the gain stored in the parameter GAINMIN is used.

Melexis strongly recommends to use AGC = 1.

Please note that the angular errors listed in the section 10 are only valid if the AGC is activated. AGC avoids also the saturation of the analog chain and the associated linearity error.

The current gain (VG) can be read out with the PTC-04 and gives a rough indication of the applied magnetic flux density (Amplitude).

14.4.3. GAINMIN and GAINMAX Parameters

GAINMIN & GAINMAX define the boundaries within the gain setting (Virtual Gain) is allowed to vary. Outside this range, the output is set in diagnostic low.

14.5. FILTER

Parameter	Value	Unit
FHYST	0 ... 11	deg
FILTER	0... 6	
FSWAP	0 1	

The MLX90324 includes 3 types of filters:

- Hysteresis Filter: programmable by the FHYST parameter
- Low Pass FIR Filters controlled with the Filter parameter
- Low Pass IIR Filter

Note: if the parameter FSWAP is set to “1”, the filtering is active on the digital angle. If set to “0”, the filtering is active on the output transfer function.

14.5.1. Hysteresis Filter

The FHYST parameter is a hysteresis filter. The output value of the IC is not updated when the digital step is smaller than the programmed FHYST parameter value. The output value is modified when the increment is bigger than the hysteresis. The hysteresis filter reduces therefore the resolution to a level compatible with the internal noise of the IC. The hysteresis must be programmed to a value close to the noise level.

Please note that for the programmable version, the FHYST parameter is set to 4 by default. If you do not wish this feature, please set it to “0”.

14.5.2. FIR Filters

The MLX90324 features 6 FIR filter modes controlled with Filter = 0...5. The transfer function is described below:

$$y_n = \frac{1}{\sum_{i=0}^j a_i} \sum_{i=0}^j a_i x_{n-i}$$

The characteristics of the filters no 0 to 5 is given in the Table 1.

Filter No (j)	0	1	2	3	4	5
Type	Disable	Finite Impulse Response				
Coefficients $a_0 \dots a_5$	N/A	110000	121000	133100	111100	122210
Title	No Filter	Extra Light		Light		
90% Response Time	1	2	3	4	4	5
99% Response Time	1	2	3	4	4	5
Efficiency RMS (dB)	0	2.9	4.0	4.7	5.6	6.2
Efficiency P2P (dB)	0	2.9	3.6	5.0	6.1	7.0

Table 1 - FIR Filters Selection Table

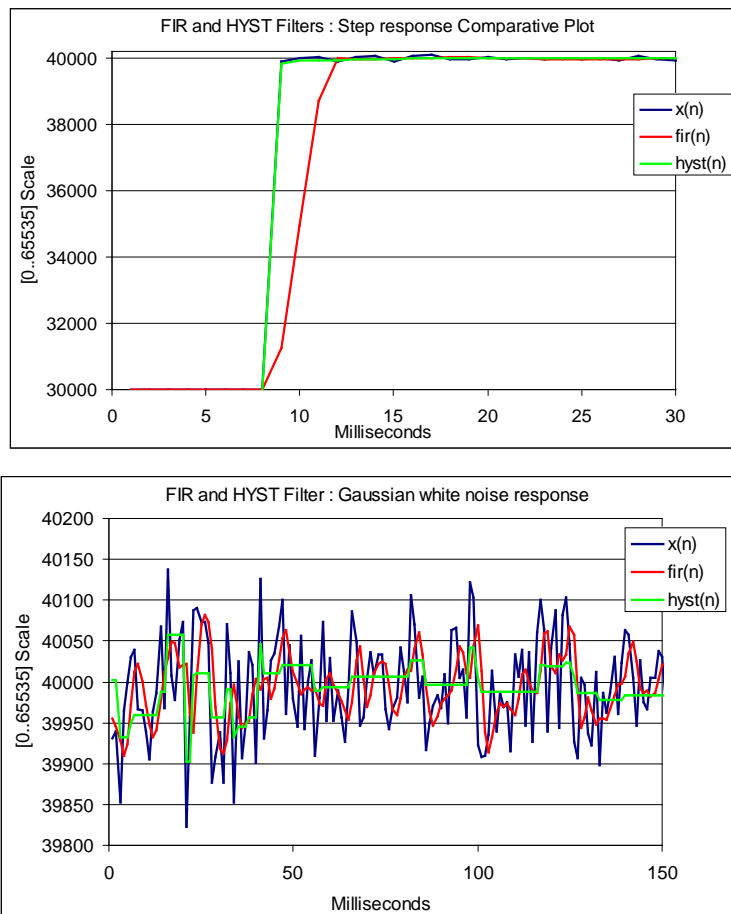

Figure 10 - Step Response and Noise Response for FIR (No 3) and FHYST=10

14.5.3. IIR Filters

The IIR Filter is enabled with Filter = 6. The diagram of the IIR Filter implemented in the MLX90324 is given in Figure 11.



Figure 11 - IIR Diagram

Filter No	6
Type	2 nd Order Infinite Impulse Response (IIR)
Title	Medium
90% Response Time	11
Efficiency RMS (dB)	9.9
Efficiency P2P (dB)	12.9
Coefficient A1	26112
Coefficient A2	10752

Table 2 - IIR Filter

The Figure 12 shows the response of the filter to a Gaussian noise.

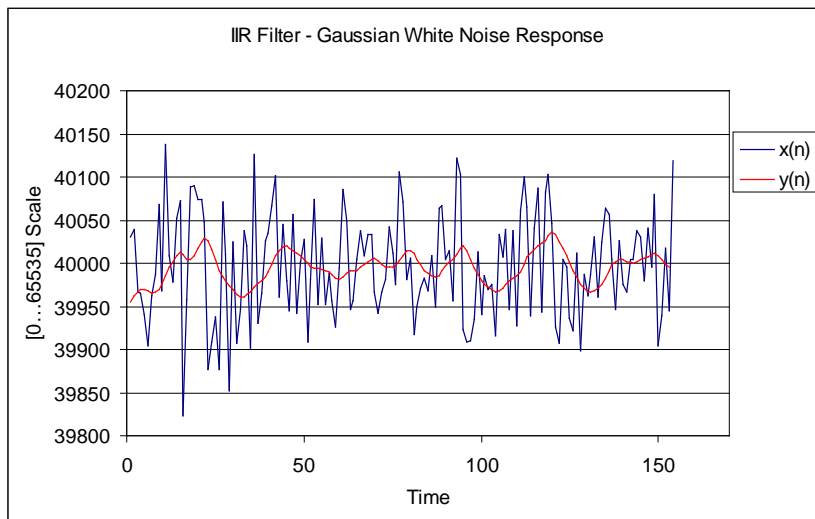

Figure 12 - Noise Response for the IIR Filter

14.6. Programmable Diagnostic Settings

Parameter	Value	Unit
RESONFAULT	0	
	1	
EEHAMHOLE	0	
	3131h	

14.6.1. RESONFAULT Parameter

This RESONFAULT parameter enables the soft reset when a fault is detected by the CPU when the parameter is set to 1. By default, the parameter is set to “0” but it is recommended to set it to “1” to activate the self diagnostic modes (See section 15).

Note that in the User Interface (MLX90324UI), the RESONFAULT is split in two bits:

- DRESONFAULT: disable the reset in case of a fault.
- DOUTINFALT: disable output in diagnostic low in case of fault.

14.6.2. EEHAMHOLE Parameter

The EEHAMHOLE parameter disables the memory recovery (Hamming code) check when a fault is detected by the CRC when it is equal to 3131h. By default the parameter is set to 0 (enable memory recovery).

14.7. Lock

Parameter	Value	Unit
MLXLOCK	0	
	1	
LOCK	0	
	1	

14.7.1. MLXLOCK Parameter

MLXLOCK locks all the parameters set by Melexis.

14.7.2. LOCK Parameter

LOCK locks all the parameters set by the user. Once the lock is enabled, it is not possible to change the EEPROM values anymore.

Note that the lock bit should be set by the solver function “MemLock”.

15. MLX90324 Self Diagnostic

The MLX90324 provides numerous self-diagnostic features. Those features increase the robustness of the IC functionality as it will prevent the IC to provide erroneous output signal in case of internal or external failure modes (“fail-safe”).

	Action	Effect on Outputs	Remark
ROM CRC Error at start up (64 words including Intelligent Watch Dog - IWD)	CPU Reset ⁽¹⁸⁾	Diagnostic low ⁽¹⁹⁾	All the outputs are already in Diagnostic low - (start-up)
ROM CRC Error (Operation - Background task)	Enter Endless Loop: - Progress (watchdog Acknowledge) - Set Outputs in Diagnostic low	Immediate Diagnostic low	
RAM Test Fail (Start up)	CPU Reset	Diagnostic low	All the outputs are already in Diagnostic low (start-up)
Calibration Data CRC Error (Start-Up)	Hamming Code Recovery		Start-Up Time is increased by 3 ms if successful recovery
Hamming Code Recovery Error (Start-Up)	CPU Reset	Immediate Diagnostic low	See 14.6.2
Calibration Data CRC Error (Operation - Background)	CPU Reset	Immediate Diagnostic low	
Dead Zone	Set Outputs in Diagnostic low. Normal Operation until the “dead zone” is left.	Immediate Diagnostic low	Immediate recovery if the “dead zone” is left
ADC Clipping (ADC Output is 0000h or 7FFFh)	Set Outputs in Diagnostic low Normal mode and CPU Reset If recovery	Immediate Diagnostic low	
Radius Overflow (> 100%) or Radius Underflow (< 40 %)	Set Outputs in Diagnostic low Normal mode and CPU Reset If recovery	Immediate Diagnostic low	(40 % - 100 %) No magnet / field too high See also 14.4.2
Gain Too Low (The current gain code is strictly less than GAINMIN)	Set Outputs in Diagnostic low Normal mode, and CPU Reset If recovery	Immediate Diagnostic low	
Gain Too High (The current gain code is strictly greater than GAINMAX)	Set Outputs in Diagnostic low Normal mode, and CPU Reset If recovery	Immediate Diagnostic low	
Redundant Temperature Sensor Mismatch	Set Outputs in Diagnostic low Normal mode, and CPU Reset If recovery	Immediate Diagnostic low	
DAC Monitor (Digital to Analog converter)	Set Outputs in Diagnostic low. Normal Mode with immediate recovery without CPU Reset	Immediate Diagnostic low	

MLX90324 Fault Mode continues...

¹⁸ CPU reset means

1. Core Reset (same as Power-On-Reset). It induces a typical start up time.
2. Periphery Reset (same as Power-On-Reset)
3. Fault Flag/Status Lost
4. The reset can be disabled by clearing the RESONFAULT bit (See 14.6.1)

¹⁹ Refer to section 7 for the Diagnostic Output Level specifications

<i>...MLX90324 Fault Mode</i>			
Fault Mode	Action	Effect on Outputs	Remark
ADC Monitor (Analog to Digital Converter)	Set Outputs in Diagnostic low. Normal Mode with immediate recovery without CPU Reset	Immediate Diagnostic low	ADC Inputs are Shorted
Undervoltage Mode	At Start-Up, wait Until VDD > 3V. During operation, CPU Reset after 3 ms debouncing	- VDD < POR level => Outputs high impedance - POR level < VDD < 3 V => Outputs in Diagnostic low.	
Firmware Flow Error	CPU Reset	Immediate Diagnostic low	Intelligent Watchdog (Observer)
Read/Write Access out of physical memory	CPU Reset	Immediate Diagnostic low	100% Hardware detection
Write Access to protected area (IO and RAM Words)	CPU Reset	Immediate Diagnostic low	100% Hardware detection
Unauthorized entry in “SYSTEM” Mode	CPU Reset	Immediate Diagnostic low	100% Hardware detection
VDD > 7 V	Set Output High Impedance (Analog)	Pull down resistive load => Diag. Low Pull up resistive load => Diag. High ⁽¹⁹⁾	100% Hardware detection
VDD > 9.4 V	IC is switched off (internal supply) CPU Reset on recovery	Pull down resistive load => Diag. Low Pull up resistive load => Diag. High	100% Hardware detection
Broken VSS	CPU Reset on recovery	Pull down resistive load => Diag. Low Pull up resistive load => Diag. High	Pull down load ($\leq 10k\Omega$) to VSS to meet Diag Lo spec < 4% VDD. Trivial
Broken VDD	CPU Reset on recovery	Pull down resistive load => Diag. Low Pull up resistive load => Diag. High	Trivial Pull up load ($\leq 10k\Omega$) to VPULLUP \geq VDD to meet Diag Hi spec > 96% VDD.

16. SENT (SAE-J2716) Protocol

16.1. Introduction

The MLX90324 features an output mode reporting the angular information and other diagnostic information (e.g. CRC) into a SENT telegram compliant with the approved SAE-J2716 Surface Vehicle Information Report.

SENT stands for Single Edge Nibble Transmission as the SENT telegram consists into the transmission of 8 Nibbles (1 nibble = 4 bits) in a row, each nibble being coded in a PWM (Pulse Width Modulation) way with reference to the falling edge.

The Single Edge Nibble Transmission encoding scheme is intended for use in applications where high resolution sensor data needs to be communicated from a sensor to an Electronic Control Unit (ECU). It is intended as a replacement for the lower resolution methods of 10 bit A/D's and PWM.

SENT is a point-to-point (i.e. it is not a data bus) unidirectional communications scheme from sensor (transmitting device) to controller (receiving device) which does not include a coordination signal from the controller/receiving device. The sensor signal is transmitted as a series of pulses with data measured as falling to falling edge times. Transmission occurs independently of any action of the receiver module, i.e. the transmission does not require a synchronization signal from the receiver module.

16.2. SENT Protocol Definition

The encoding scheme consists of a sequence of pulses which is repeatedly sent by the transmitting module.

The time granularity of the transmission is defined as the Clock Tick which is specified as follows:

$$3 \mu\text{s} \leq \text{Clock Tick} \leq 10 \mu\text{s}$$

Each nibble is defined in a PWM way:

- the output is first driven LOW (falling edge) for **5 Clock Ticks**,
- then driven HIGH for **7 Clock Ticks + n × Clock Ticks** where n is the decimal value of the nibble.

For a nibble value of 0 (minimum), the output is driven LOW for 5 Clock Ticks then driven HIGH for 7 Clock Ticks. Total period for the shortest nibble (n = 0) is therefore 12 Clock Ticks. See Figure 13.

For a nibble value of 15 (maximum), the output is driven LOW for 5 Clock Ticks then driven HIGH for 22 Clock Ticks. Total period for the longest nibble (n = 15) is therefore 27 Clock Ticks. See Figure 14.

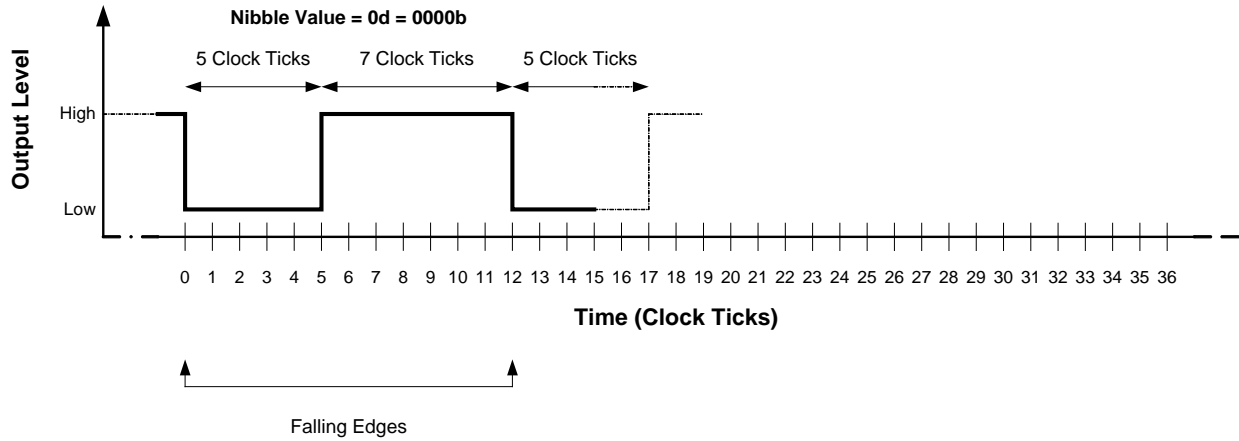

Figure 13 – Timing Diagram for Nibble Value = 0d

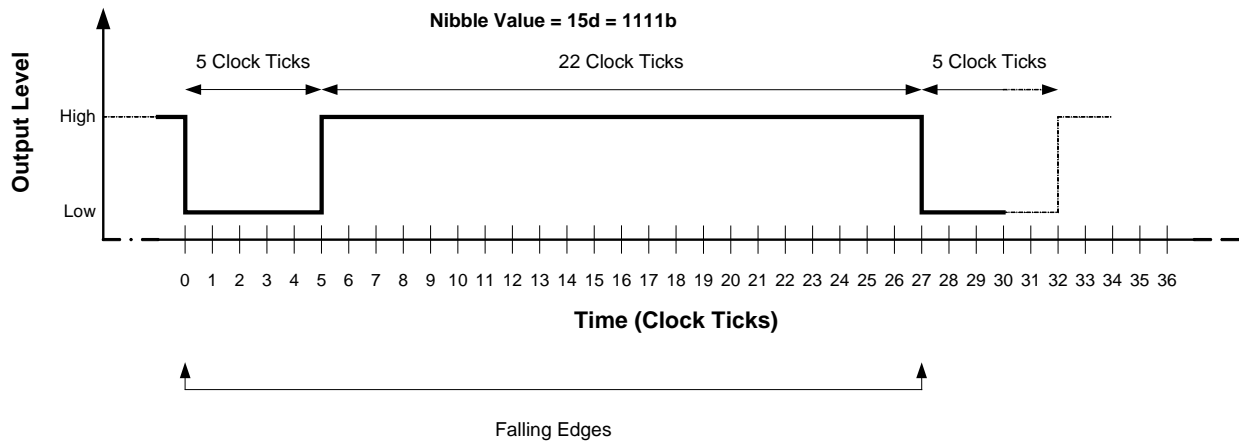

Figure 14 – Timing Diagram for Nibble Value = 15d

Nibble Value		Output LOW (# Clock Ticks)	Output HIGH (# Clock Ticks)	Nibble Period (# Clock Ticks)
Decimal (n)	Binary			
0d	0000b	5	7	12
1d	0001b	5	8	13
2d	0010b	5	9	14
3d	0011b	5	10	15
4d	0100b	5	11	16
5d	0101b	5	12	17
6d	0110b	5	13	18
7d	0111b	5	14	19
8d	1000b	5	15	20
9d	1001b	5	16	21
10d	1010b	5	17	22
11d	1011b	5	18	23
12d	1100b	5	19	24
13d	1101b	5	20	25
14d	1110b	5	21	26
15d	1111b	5	22	27

The transmission itself consists of the following sequence:

- “Calibration/Synchronization” pulse period 56 Clock Ticks
- One “Status and Communication” nibble pulse (Nibble #1)
- A sequence of six “Data” nibble pulses (Nibble #2 ... #7)
- One “Checksum” (CRC) nibble pulse (Nibble #8)

Figure 15 shows a single message transmission for which

- Nibble #1 = 0d
- Nibble #2 = 15d
- Nibble #3 = 0d
- Nibble #4 = 8d
- Nibble #5 = 15d
- Nibble #6 = 0d
- Nibble #7 = 8d
- Nibble #8 = 12d (for example purpose – please note that this nibble may not necessarily match the CRC definition)



Figure 15 – Single SENT Message Transmission

The transmission delay of one message depends on the content of the nibbles but the minimum and maximum boundaries are 152 Clock Ticks (456 μ s if Clock Tick = 3 μ s) and 272 Clock Ticks (816 μ s if Clock Tick = 3 μ s).

The “Calibration/Synchronization” pulse period is measured by the receiver in order to calculate the actual duration of the Clock Tick. In this way, the frequency variations of the main oscillator at the transmitter (i.e. the sensor) can be compensated. The allowable frequency variation is $\pm 20\%$.

The “Status and Communication” nibble is used to transmit internal status or diagnostic information. The content varies according to the SENT implementation (see Section 16.3 for the implemented SENT version of MLX90324).

The “Checksum” nibble contains a 4 bit CRC of the Data nibbles only. The “Status and Communication Nibble” is not included in the CRC calculation. The CRC is calculated using polynomial $x^4 + x^3 + x^2 + 1$ with seed value of 0101.

16.3. SENT Protocol Implementation

The MLX90324 implements the Single Secure Sensors format described in the Appendix (Section A.3) of SAE-J2716 definition.

The Clock Tick is specified at 3 μ s.

The angular information (12 bits) is spread over 3 data nibbles. A 8-bit rolling counter 0 to 255 with rollover back to 0 is included in 2 data nibbles. The last data nibble is derived from the 1st data nibble including the MSBs (Most Significant Bits) of the computed angle.

- Nibble #1 = “Status” Nibble
 - When the sensor is determined to be faulted, Bit 0 of the Status Nibble is set to 1 otherwise bit set to 0
 - Bit 1, Bit 2 and Bit 3 are set to 0.
- Nibble #2 = Angular Information – MSN (Most Significant Nibble)
- Nibble #3 = Angular Information – MidN (Middle Nibble)
- Nibble #4 = Angular Information – LSN (Least Significant Nibble)
- Nibble #5 = 8 bit rolling counter – MSN (Most Significant Nibble)
- Nibble #6 = 8 bit rolling counter – LSN (Least Significant Nibble)
- Nibble #7 = Inverted copy of Nibble #2 (15 – Nibble #2 value)
- Nibble #8 = “Checksum” Nibble

The rolling counter can be disabled (to match the “single sensor” format of the Appendix A.4 of the SAE-J2716): in this case, Nibble #5 and Nibble #6 are set to 0. See in the End-User programmable item to see how to disable it (Section 14.1.3)

16.4. Use of the MLX90324 SENT Feature

In order to enable the SENT output reporting mode, specific parameters (stored in EEPROM) of the MLX90324 needs to be programmed. While using the Melexis programming tools, the whole operation is actually controlled through a single item as described on Section 14.1.3.

The SAE-J2716 recommends a generic application diagram for both the transmitter and the receiver in order to pass the EMC norms, especially the emissions (e.g. radiated emission, conducted emission) requirements.

This recommended circuitry applied to the MLX90324LDC (single die – SOIC-8) is shown at the Section 17.4 and MLX90324LGO (dual die – TSSOP-16) is shown at the Section 17.5.

17. Recommended Application Diagrams

17.1. Analog Output Wiring with the MLX90324 in SOIC Package



Figure 16 – Recommended wiring for the MLX90324 in SOIC8 package⁽²⁰⁾.

²⁰ See section 14.1.4 if the Switch Output feature is used.

17.2. Analog Output Wiring with the MLX90324 in TSSOP Package



Figure 17 – Recommended wiring for the MLX90324 in TSSOP16 package (dual die).

17.3. PWM Low Side Output Wiring



Figure 18 – Recommended wiring for a PWM Low Side Output configuration⁽²¹⁾.

²¹ See section 14.1.4 if the Switch Output feature is used.

17.4. SENT Output Wiring with the MLX90324 in SOIC-8 package

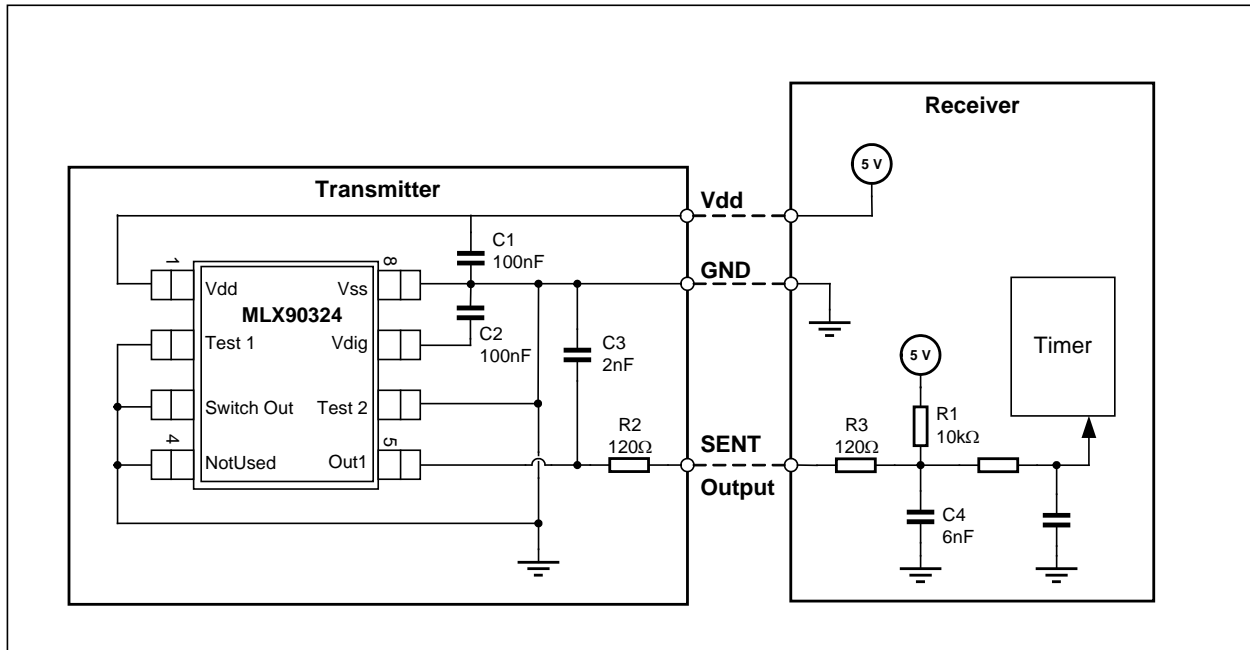

Figure 19 – Recommended Application Diagram for the Transmitter & Receiver

17.5. SENT Output Wiring with the MLX90324 in TSSOP-16 package

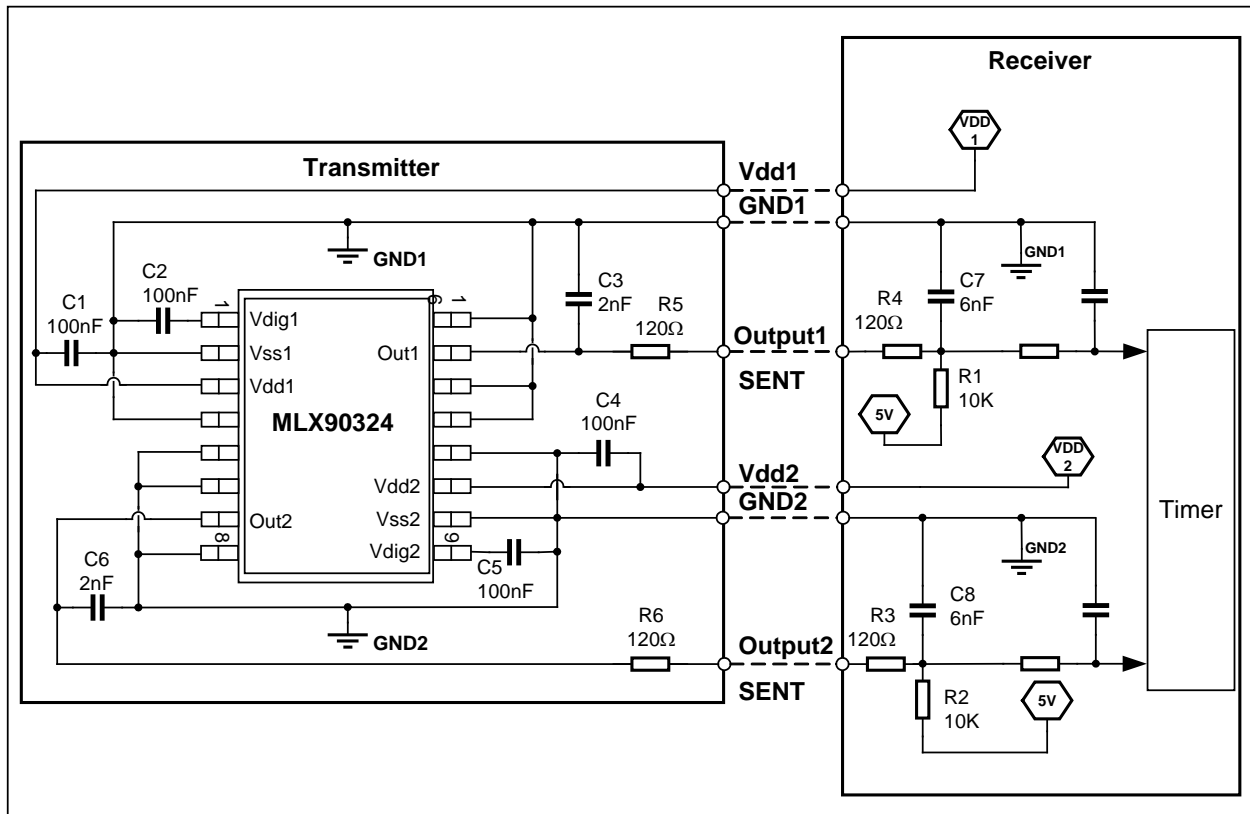

Figure 20 – Recommended Application Diagram for the Transmitter & Receiver in TSSOP package

18. Standard information regarding manufacturability of Melexis products with different soldering processes

Our products are classified and qualified regarding soldering technology, solderability and moisture sensitivity level according to following test methods:

Reflow Soldering SMD's (Surface Mount Devices)

- IPC/JEDEC J-STD-020
Moisture/Reflow Sensitivity Classification for Nonhermetic Solid State Surface Mount Devices (classification reflow profiles according to table 5-2)
- EIA/JEDEC JESD22-A113
Preconditioning of Nonhermetic Surface Mount Devices Prior to Reliability Testing (reflow profiles according to table 2)

Wave Soldering SMD's (Surface Mount Devices) and THD's (Through Hole Devices)

- EN60749-20
Resistance of plastic- encapsulated SMD's to combined effect of moisture and soldering heat
- EIA/JEDEC JESD22-B106 and EN60749-15
Resistance to soldering temperature for through-hole mounted devices

Iron Soldering THD's (Through Hole Devices)

- EN60749-15
Resistance to soldering temperature for through-hole mounted devices

Solderability SMD's (Surface Mount Devices) and THD's (Through Hole Devices)

- EIA/JEDEC JESD22-B102 and EN60749-21
Solderability

For all soldering technologies deviating from above mentioned standard conditions (regarding peak temperature, temperature gradient, temperature profile etc) additional classification and qualification tests have to be agreed upon with Melexis.

The application of Wave Soldering for SMD's is allowed only after consulting Melexis regarding assurance of adhesive strength between device and board.

Melexis recommends reviewing on our web site the General Guidelines [soldering recommendation](http://www.melexis.com/Quality_soldering.aspx) (http://www.melexis.com/Quality_soldering.aspx) as well as [trim&form recommendations](http://www.melexis.com/Assets/Trim-and-form-recommendations-5565.aspx) (<http://www.melexis.com/Assets/Trim-and-form-recommendations-5565.aspx>).

Melexis is contributing to global environmental conservation by promoting **lead free** solutions. For more information on qualifications of **RoHS** compliant products (RoHS = European directive on the Restriction Of the use of certain Hazardous Substances) please visit the quality page on our website: <http://www.melexis.com/quality.aspx>

19. ESD Precautions

Electronic semiconductor products are sensitive to Electro Static Discharge (ESD). Always observe Electro Static Discharge control procedures whenever handling semiconductor products.

20. Package Information

20.1. SOIC8 - Package Dimensions

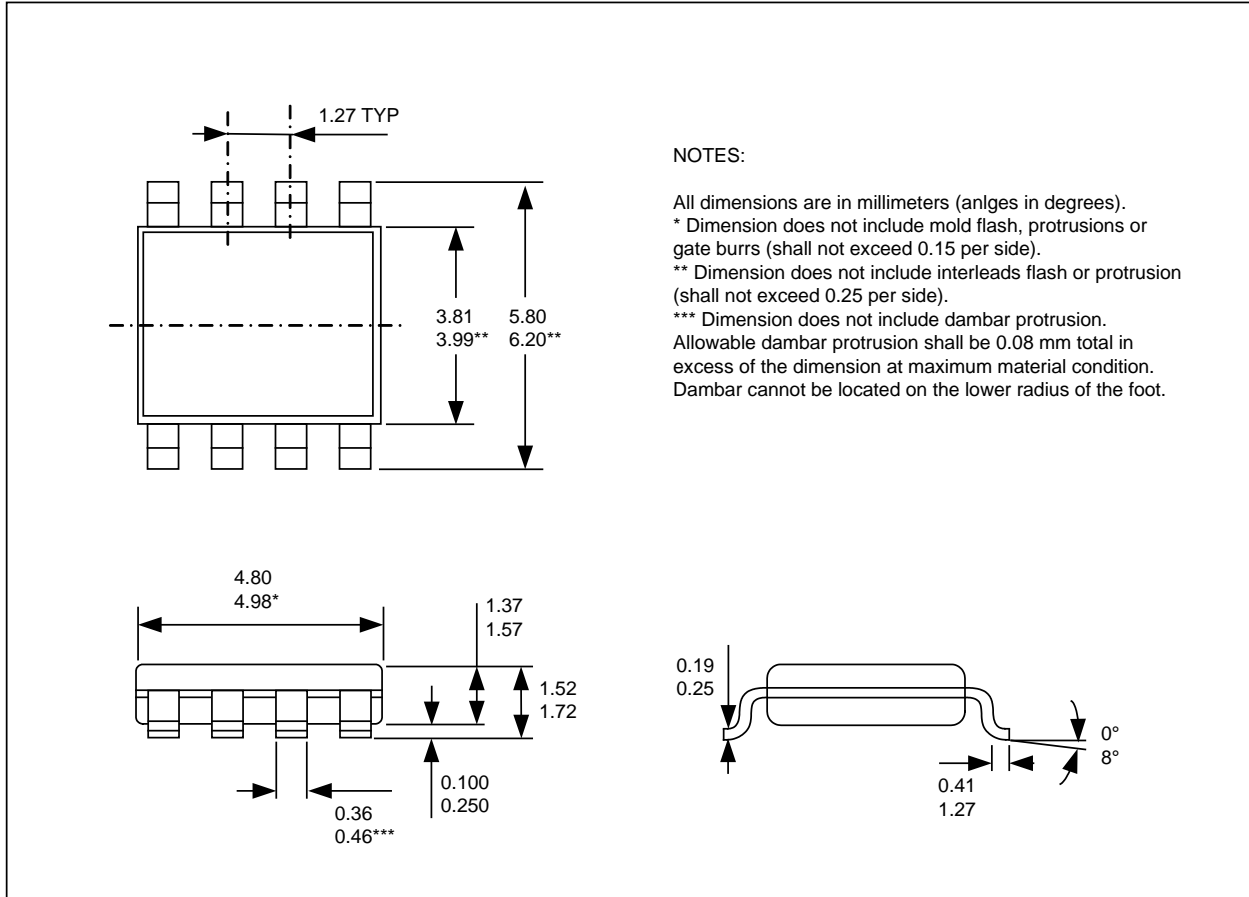

20.2. SOIC8 - Pinout and Marking



20.3. SOIC8 - IMC Positioning



Angle detection MLX90324 SOIC8

~ 0 Deg.*

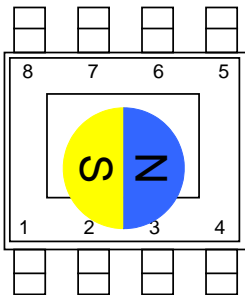

~ 90 Deg.*

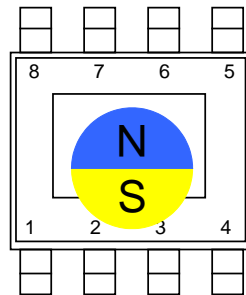

~ 180 Deg.*

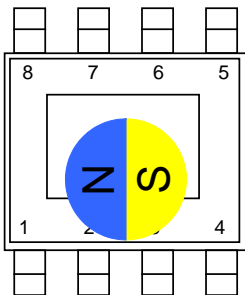

~ 270 Deg.*

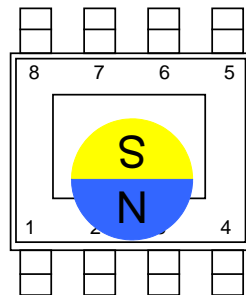

* No absolute reference for the angular information.

The MLX90324 is an absolute angular position sensor but the linearity error (Le – See Section 10) does not include the error linked to the absolute reference 0 Deg (which can be fixed in the application through the discontinuity point – See 14.2.2).

20.4. TSSOP16 - Package Dimensions

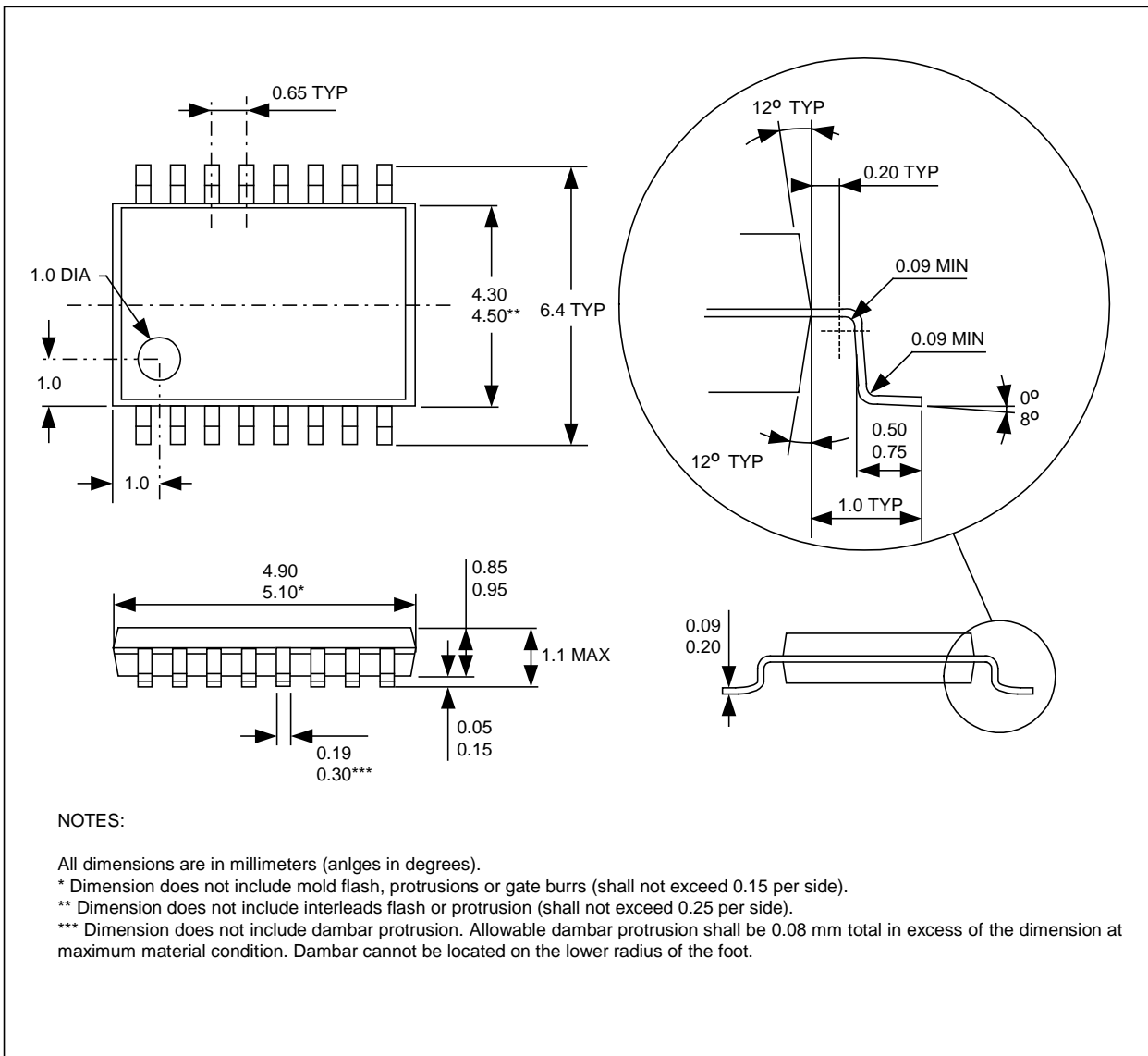

20.5. TSSOP16 - Pinout and Marking



20.6. TSSOP16 - IMC Positioning

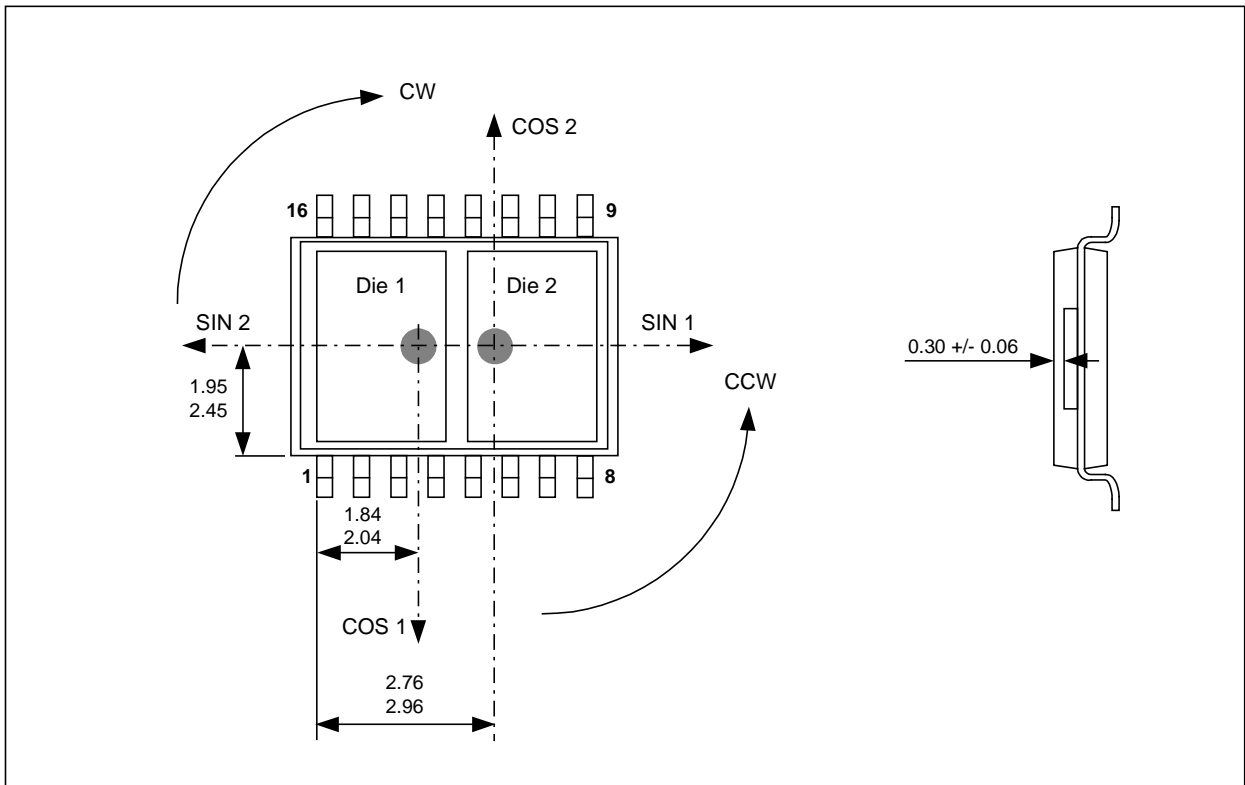



The MLX90324 is an absolute angular position sensor but the linearity error (Le – See Section 10) does not include the error linked to the absolute reference 0 Deg (which can be fixed in the application through the discontinuity point – See 14.2.2).

21. Disclaimer

The information furnished by Melexis herein (“Information”) is believed to be correct and accurate. Melexis disclaims (i) any and all liability in connection with or arising out of the furnishing, performance or use of the technical data or use of the product(s) as described herein (“Product”) (ii) any and all liability, including without limitation, special, consequential or incidental damages, and (iii) any and all warranties, express, statutory, implied, or by description, including warranties of fitness for particular purpose, non-infringement and merchantability. No obligation or liability shall arise or flow out of Melexis’ rendering of technical or other services.

The Information is provided “as is” and Melexis reserves the right to change the Information at any time and without notice. Therefore, before placing orders and/or prior to designing the Product into a system, users or any third party should obtain the latest version of the relevant information to verify that the information being relied upon is current.

Users or any third party must further determine the suitability of the Product for its application, including the level of reliability required and determine whether it is fit for a particular purpose.

The Information is proprietary and/or confidential information of Melexis and the use thereof or anything described by the Information does not grant, explicitly or implicitly, to any party any patent rights, licenses, or any other intellectual property rights.

This document as well as the Product(s) may be subject to export control regulations. Please be aware that export might require a prior authorization from competent authorities.

The Product(s) are intended for use in normal commercial applications. Unless otherwise agreed upon in writing, the Product(s) are not designed, authorized or warranted to be suitable in applications requiring extended temperature range and/or unusual environmental requirements. High reliability applications, such as medical life-support or life-sustaining equipment are specifically not recommended by Melexis. The Product(s) may not be used for the following applications subject to export control regulations: the development, production, processing, operation, maintenance, storage, recognition or proliferation of 1) chemical, biological or nuclear weapons, or for the development, production, maintenance or storage of missiles for such weapons; 2) civil firearms, including spare parts or ammunition for such arms; 3) defense related products, or other material for military use or for law enforcement; 4) any applications that, alone or in combination with other goods, substances or organisms could cause serious harm to persons or goods and that can be used as a means of violence in an armed conflict or any similar violent situation.

The Products sold by Melexis are subject to the terms and conditions as specified in the Terms of Sale, which can be found at <https://www.melexis.com/en/legal/terms-and-conditions>.

This document supersedes and replaces all prior information regarding the Product(s) and/or previous versions of this document.

Melexis NV © - No part of this document may be reproduced without the prior written consent of Melexis. (2017)

ISO/TS 16949 and ISO14001 Certified

For the latest version of this document, go to our website at
www.melexis.com

Or for additional information contact Melexis Direct:

Europe, Africa, Asia:	America:
Phone: +32 1367 0495	Phone: +1 248 306 5400
E-mail: sales_europe@melexis.com	E-mail: sales_usa@melexis.com

ISO/TS 16949 and ISO14001 Certified

Компания «Океан Электроники» предлагает заключение долгосрочных отношений при поставках импортных электронных компонентов на взаимовыгодных условиях!

Наши преимущества:

- Поставка оригинальных импортных электронных компонентов напрямую с производств Америки, Европы и Азии, а так же с крупнейших складов мира;
- Широкая линейка поставок активных и пассивных импортных электронных компонентов (более 30 млн. наименований);
- Поставка сложных, дефицитных, либо снятых с производства позиций;
- Оперативные сроки поставки под заказ (от 5 рабочих дней);
- Экспресс доставка в любую точку России;
- Помощь Конструкторского Отдела и консультации квалифицированных инженеров;
- Техническая поддержка проекта, помощь в подборе аналогов, поставка прототипов;
- Поставка электронных компонентов под контролем ВП;
- Система менеджмента качества сертифицирована по Международному стандарту ISO 9001;
- При необходимости вся продукция военного и аэрокосмического назначения проходит испытания и сертификацию в лаборатории (по согласованию с заказчиком);
- Поставка специализированных компонентов военного и аэрокосмического уровня качества (Xilinx, Altera, Analog Devices, Intersil, Interpoint, Microsemi, Actel, Aeroflex, Peregrine, VPT, Syfer, Eurofarad, Texas Instruments, MS Kennedy, Miteq, Cobham, E2V, MA-COM, Hittite, Mini-Circuits, General Dynamics и др.);

Компания «Океан Электроники» является официальным дистрибьютором и эксклюзивным представителем в России одного из крупнейших производителей разъемов военного и аэрокосмического назначения «JONHON», а так же официальным дистрибьютором и эксклюзивным представителем в России производителя высокотехнологичных и надежных решений для передачи СВЧ сигналов «FORSTAR».



JONHON

«JONHON» (основан в 1970 г.)

Разъемы специального, военного и аэрокосмического назначения:

(Применяются в военной, авиационной, аэрокосмической, морской, железнодорожной, горно- и нефтедобывающей отраслях промышленности)

«FORSTAR» (основан в 1998 г.)

ВЧ соединители, коаксиальные кабели,
кабельные сборки и микроволновые компоненты:

(Применяются в телекоммуникациях гражданского и специального назначения, в средствах связи, РЛС, а так же военной, авиационной и аэрокосмической отраслях промышленности).



Телефон: 8 (812) 309-75-97 (многоканальный)

Факс: 8 (812) 320-03-32

Электронная почта: ocean@oceanchips.ru

Web: <http://oceanchips.ru/>

Адрес: 198099, г. Санкт-Петербург, ул. Калинина, д. 2, корп. 4, лит. А