



SMBus Multi-Output Power-Supply Controller

DESCRIPTION

The Si9135 is a current-mode PWM and PSM converter controller, with two synchronous buck converters (3.3 V and 5 V) and a flyback (non-isolated buck-boost) converter (12 V). Designed for portable devices, it offers a total five power outputs (three tightly regulated dc/dc converter outputs, a precision 3.3 V reference and a 5 V LDO output). It requires minimum external components and is capable of achieving conversion efficiencies approaching 95 %.

Along with the SMBUS interface, the Si9135 provides programmable output selection capability.

The Si9135 is available in both standard and lead (Pb)-free 28-pin SSOP packages and specified to operate over the extended commercial (0 °C to 90 °C) temperature range.

FEATURES

- Up to 95 % Efficiency
- 3 % Total Regulation (Each Controller)
- 5.5 V to 30 V Input Voltage Range
- 3.3 V, 5 V, and 12 V Outputs
- 200 kHz/300 kHz Low-Noise Frequency Operation
- Precision 3.3 V Reference Output
- 30 mA Linear Regulator Output
- SMBUS Interface
- High Efficiency Pulse Skipping Mode Operation at Light Load
- Only Three Inductors Required - No Transformer
- LITTLE FOOT® Optimized Output Drivers
- Internal Soft-Start
- Synchronizable
- Minimal External Control Components
- 28-Pin SSOP Package

FUNCTIONAL BLOCK DIAGRAM

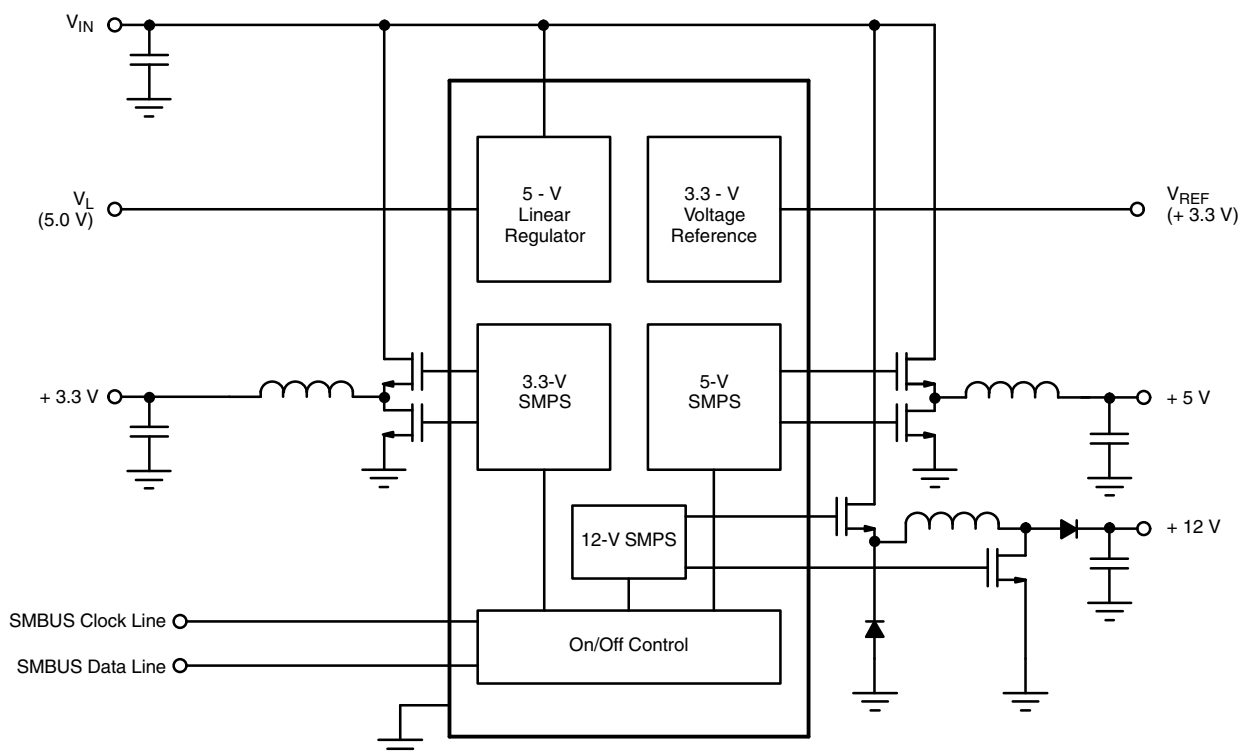

ABSOLUTE MAXIMUM RATINGS			
Parameter		Limit	Unit
V_{IN} to GND		- 0.3 to + 36	V
P_{GND} to GND		± 2	
V_L to GND		- 0.3 to + 6.5	
BST ₃ , BST ₅ , BSTFY to GND		- 0.3 to + 36	
V_L Short to GND		Continuous	
LX ₃ to BST ₃ ; LX ₅ to BST ₅ ; LXFY to BST		- 6.5 to 0.3	V
Inputs/Outputs to GND (SYNC, CS ₃ , CS ₅ , CSP, CSN)		- 0.3 V to ($V_L + 0.3$)	
SDA, SCL		- 0.3 to + 5.5	
DL3, DL5, DLFY to PGND		- 0.3 V to ($V_L + 0.3$)	
DH3 to LX ₃ , DH5 to LX ₅ , DHFY to LXFY		- 0.3 V to (BSTX + 0.3)	
Continuous Power Dissipation ($T_A = 90\text{ }^\circ\text{C}$) ^a	28-Pin SSOP ^b	572	mW
Operating Temperature Range		0 to 90	°C
Storage Temperature Range		- 40 to 125	
Lead Temperature (Soldering, 10 Sec.)		300	

Notes:

- a. Device Mounted with all leads soldered or welded to PC board.
b. Derate 9.52 mW/°C above 90 °C.

Stresses beyond those listed under "Absolute Maximum Ratings" may cause permanent damage to the device. These are stress ratings only, and functional operation of the device at these or any other conditions beyond those indicated in the operational sections of the specifications is not implied. Exposure to absolute maximum rating conditions for extended periods may affect device reliability.

SPECIFICATIONS						
Parameter	Specific Test Conditions $V_{IN} = 15\text{ V}$, $I_{VL} = I_{REF} = 0\text{ mA}$ $T_A = 0\text{ }^\circ\text{C}$ to $90\text{ }^\circ\text{C}$, All Converters ON	Limits			Unit	
		Min. ^a	Typ. ^b	Max. ^a		
3.3 V Buck Controller						
Total Regulation (Line, Load, and Temperature)	$V_{IN} = 6$ to 30 , $0 < V_{CS3} - V_{FB3} < 90\text{ mV}$	3.23	3.33	3.43	V	
Line Regulation	$V_{IN} = 6$ to 30 V			± 0.5	%	
Load Regulation	$0 < V_{CS3} - V_{FB3} < 90\text{ mV}$			± 0.5		
Current Limit	$V_{CS3} - V_{FB3}$	90	125	160	mV	
Bandwidth	$L = 10\text{ }\mu\text{H}$, $C = 330\text{ }\mu\text{F}$		50		kHz	
Phase Margin	$R_{SENSE} = 20\text{ m}\Omega$		65		°	
5 V Buck Controller						
Total Regulation (Line, Load, and Temperature)	$V_{IN} = 6$ to 30 , $0 < V_{CS5} - V_{FB5} < 90\text{ mV}$	4.88	5.03	5.18	V	
Line Regulation	$V_{IN} = 6$ to 30 V			± 0.5	%	
Load Regulation	$0 < V_{CS5} - V_{FB5} < 90\text{ mV}$			± 0.5		
Current Limit	$V_{CS5} - V_{FB5}$	90	125	160	mV	
Bandwidth	$L = 10\text{ }\mu\text{H}$, $C = 330\text{ }\mu\text{F}$		50		kHz	
Phase Margin	$R_{SENSE} = 20\text{ m}\Omega$		60		°	
12 V Flyback Controller						
Total Regulation (Line, Load, and Temperature)	$V_{IN} = 6$ to 30 , $0 < V_{CSP} - V_{CSN} < 300\text{ mV}$	11.4	12.0	12.6	V	
Line Regulation	$V_{IN} = 6$ to 30 V			± 0.5	%	
Load Regulation	$0 < V_{CSP} - V_{FBN} < 300\text{ mV}$			± 0.5		
Current Limit	$V_{CSP} - V_{CSN}$	330	410	510	mV	
Bandwidth	$L = 10\text{ }\mu\text{H}$, $C = 100\text{ }\mu\text{F}$		10		kHz	
Phase Margin	$R_{SENSE} = 100\text{ m}\Omega$, $C_{comp} = 120\text{ pF}$		65		°	



SPECIFICATIONS						
Parameter	Specific Test Conditions $V_{IN} = 15\text{ V}$, $I_{VL} = I_{REF} = 0\text{ mA}$ $T_A = 0\text{ }^\circ\text{C}$ to $90\text{ }^\circ\text{C}$, All Converters ON	Limits			Unit	
		Min. ^a	Typ. ^b	Max. ^a		
Internal Regulator						
V_L Output	All Converters OFF, $V_{IN} > 5.5\text{ V}$, $0 < I_L < 30\text{ mA}$	4.7		5.5	V	
V_L Fault Lockout Voltage		3.6		4.2		
V_L Fault Lockout Hysteresis			75		mV	
V_L /FB5 Switchover Voltage		4.2		4.7	V	
V_L /FB5 Switchover Hysteresis			75		mV	
Reference						
REF Output	No External Load	3.24	3.30	3.36	V	
REF Load Regulation	0 to 1 mA		30	75	mV	
Supply Current						
Supply Current - Shutdown	All Converters OFF, No Load		35	60	μA	
Supply Current - Operation	All Converters ON, No Load, $F_{OCS} = 200\text{ kHz}$		1100	1800		
Oscillator						
Oscillator Frequency	SYNC tied to REF	270	300	330	kHz	
	SYNC tied to GND or V_L	180	200	220		
SYNC High-Pulse Width		200			nsec	
SYNC Low-Pulse Width		200				
SYNC Rise/Fall Range				200		
SYNC V_{IL}				0.8	V	
SYNC V_{IH}		$V_L - 0.5$				
Oscillator SYNC Range		250		400	kHz	
Maximum Duty Cycle	SYNC tied to GND or V_L	92	95		%	
	SYNC tied to REF	89	92			
Outputs						
Gate Driver Sink/Source Current (Buck)	DL3, DH3, DL5, DH5 Forced to 2 V		1		A	
Gate Driver On-Resistance (Buck)	High or Low		2	7	Ω	
Gate Driver Sink/Source Current (Flyback)	DHFY, DLFY Forced to 2 V		0.2		A	
Gate Driver On-Resistance (Flyback)	High or Low			15	Ω	
SCL, SDA						
V_{IL}				0.6	V	
V_{IH}		1.4				

Notes:

- a. The algebraic convention whereby the most negative value is a minimum and the most positive a maximum.
- b. Typical values are for DESIGN AID ONLY, not guaranteed nor subject to production testing.

PIN CONFIGURATION

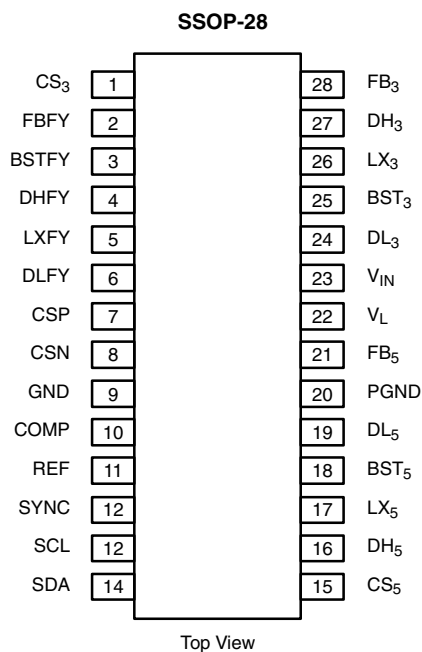

ORDERING INFORMATION

Part Number	Lead (Pb)-free Part Number	Temperature Range	V _{OUT}
Si9135LG		0 to 90 °C	3.3 V, 5 V, 12 V
Si9135LG-T1	Si9135LG-T1-E3		

PIN DESCRIPTION

Pin Number	Symbol	Description
1	CS ₃	Current sense input for 3.3 V buck.
2	FBFY	Feedback for flyback.
3	BSTFY	Boost capacitor connection for flyback converter.
4	DHfy	Gate-drive output for flyback high-side MOSFET.
5	LXfy	Inductor connection for flyback converter.
6	DLfy	Gate-drive output for flyback low-side MOSFET.
7	CSP	Current sense positive input for flyback converter.
8	CSN	Current sense negative input for flyback converter.
9	GND	Analog ground.
10	COMP	Flyback compensation connection, if required.
11	REF	3.3 V internal reference.
12	SYNC	Oscillator synchronization inputs.
13	SCL	SMBUS clock line.
14	SDA	SMBUS data line.
15	CS ₅	Current sense input for 5 V buck controller.
16	DH ₅	Inductor connection for buck 5 V.
17	LX ₅	Gate-drive output for 5 V buck high-side MOSFET.
18	BST ₅	Boost capacitor connection for 5 V buck converter.
19	DL ₅	Gate-drive output for 5 V buck low-side MOSFET.
20	PGND	Power ground.
21	FB ₅	Feedback for 5 V buck.
22	V _L	5 V logic supply voltage for internal circuitry.
23	V _{IN}	Input voltage
24	DL ₃	Gate-drive output for 3.3 V buck low-side MOSFET.
25	BST ₃	Boost capacitor connection for 3.3 V buck converter.
26	LX ₃	Inductor connection for 3.3 V buck low-side MOSFET.
27	DH ₃	Gate-drive output for 3.3 V buck high-side MOSFET.
28	FB ₃	Feedback for 3.3 V buck.

TYPICAL CHARACTERISTICS (25 °C unless otherwise noted)

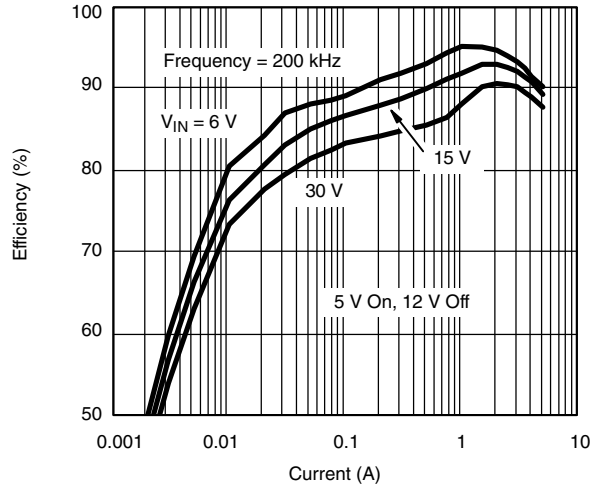

Efficiency vs. 3.3 V Output Current

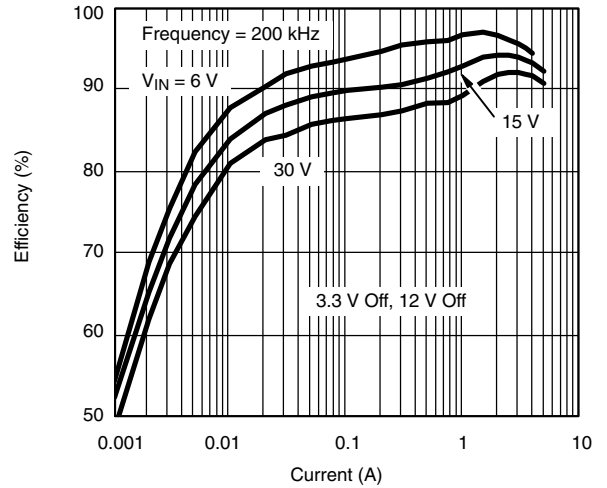

Efficiency vs. 5.0 V Output Current

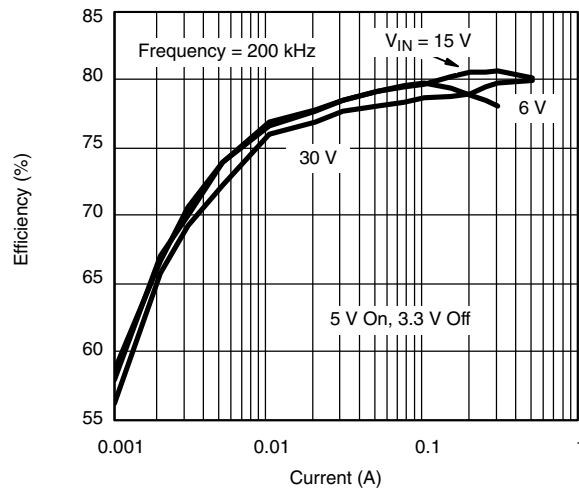

Efficiency vs. 12 V Output Current

TYPICAL WAVEFORMS

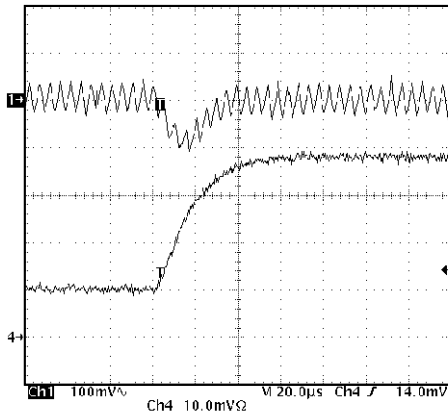

PWM Loading
5 V Converter ($V_{IN} = 10\text{ V}$)

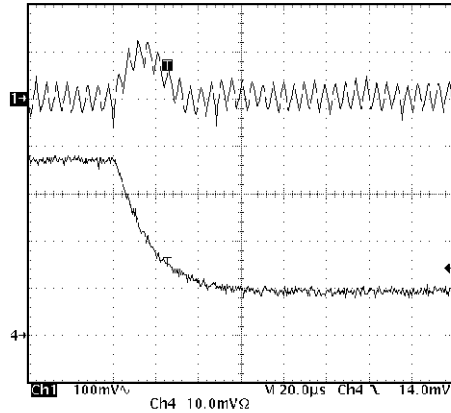

PWM Unloading
5 V Converter ($V_{IN} = 10\text{ V}$)

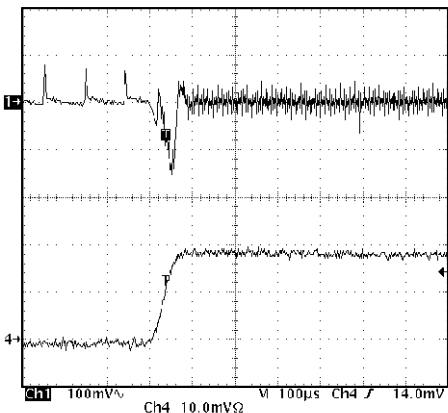

PSM \rightarrow PWM
5 V Converter ($V_{IN} = 10\text{ V}$)

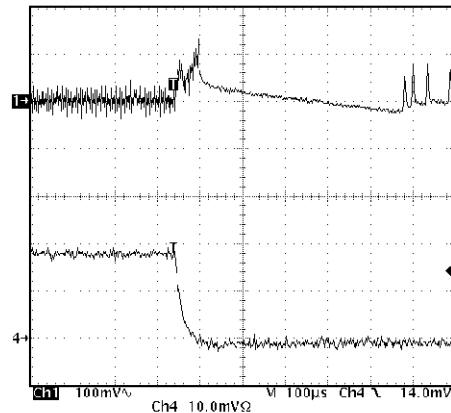

PWM \rightarrow PSM
5 V Converter ($V_{IN} = 10\text{ V}$)

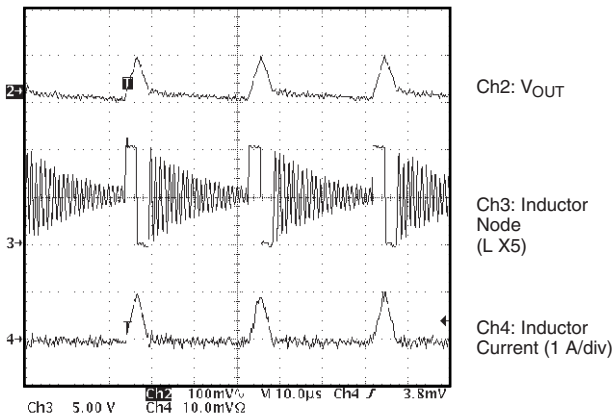

PSM Operation
5 V Converter ($V_{IN} = 10\text{ V}$)

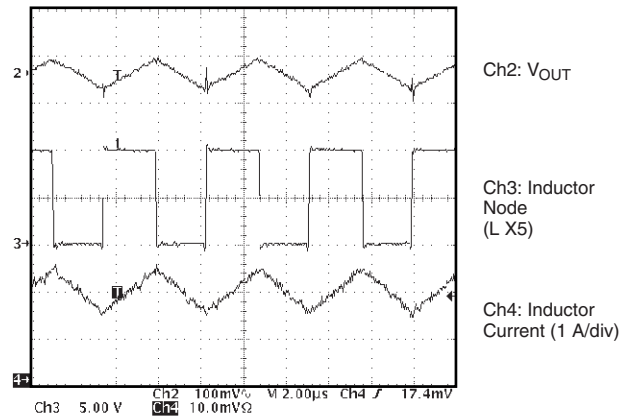

PWM Operation
5 V Converter ($V_{IN} = 10\text{ V}$)

TYPICAL WAVEFORMS

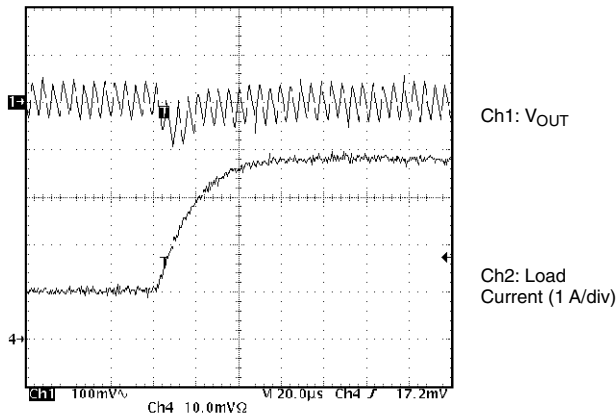

PWM, Loading
3 V Converter (V_{IN} = 10 V)

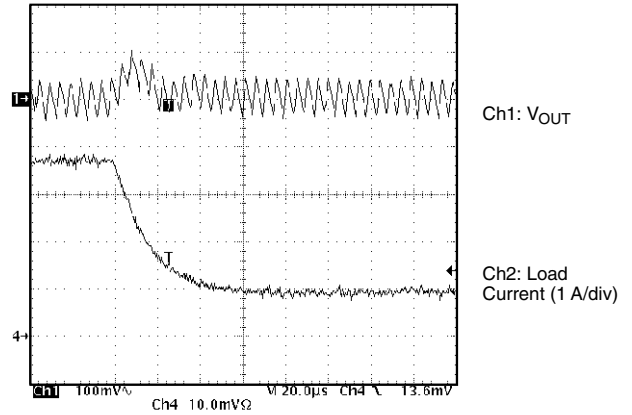

PWM, Unloading
3 V Converter (V_{IN} = 10 V)

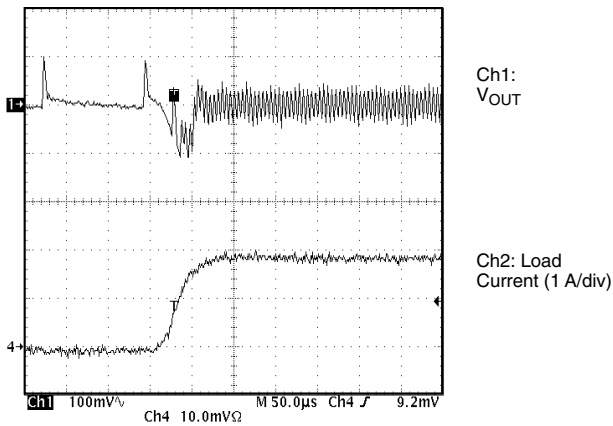

PSM to PWM
3 V Converter (V_{IN} = 10 V)

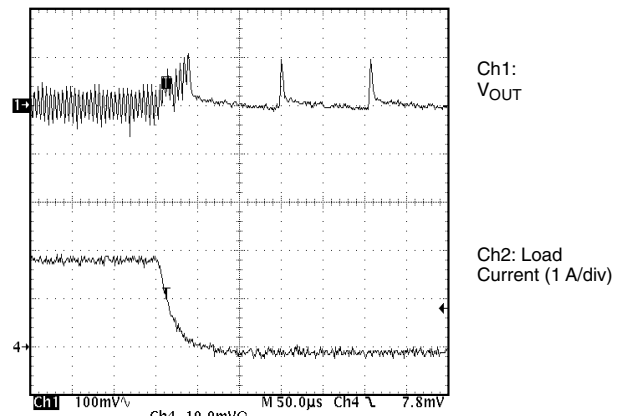

PWM to PSM
3 V Converter (V_{IN} = 10 V)

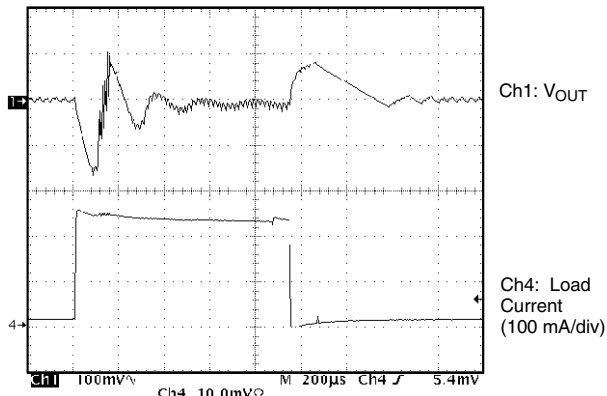

250 - mA Transient
12 V Converter (V_{IN} = 10 V)

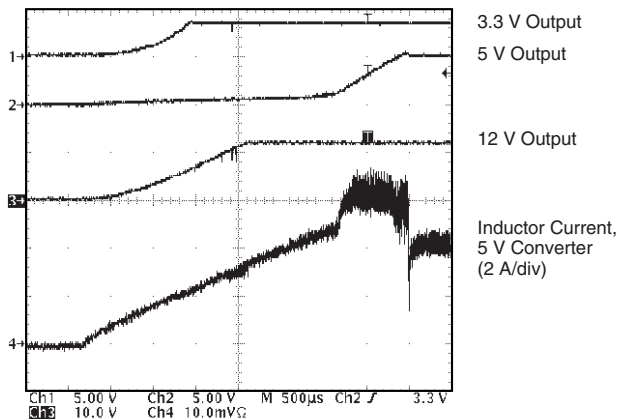

Start-Up

STANDARD APPLICATION CIRCUIT

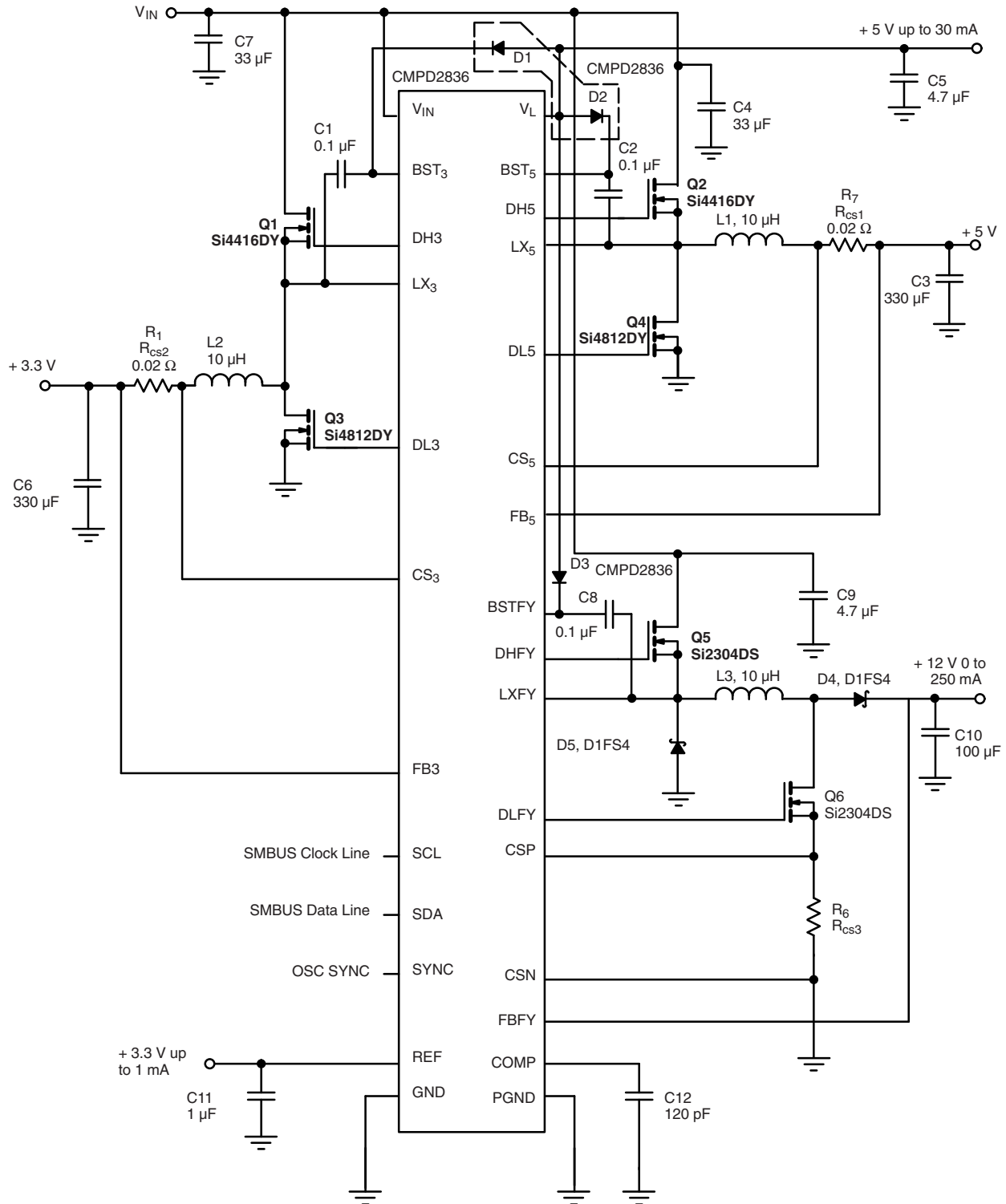

Figure 1.



SMBUS Specification

SMBus: The System Management Bus is a two-wire interface through which simple power related chips can communicate with the rest of the system. It uses I²C as its backbone. Both SDA and SCL are bidirectional lines, connected to a positive voltage via a pull-up resistor. When

the bus is free, both lines are high. The output stages of devices connected to the bus must have an open drain or open collector in order to perform the wired AND function. Data on the SMBus can be transferred at a clock rate up to 100 kHz. Si9135 is a slave with SMBus address of 0110000.

SMBUS TRUTH TABLE								
State	D7	D6	D5	D4	D3	D2	D1	D0
Shutdown	0	0	0	X	X	X	X	X
Buck3 On	1	0	0	X	X	X	X	X
Buck5 On	0	1	0	X	X	X	X	X
Flyback On	0	0	1	X	X	X	X	X
Buck3, Buck5 On	1	1	0	X	X	X	X	X
Buck3, Flyback On	1	0	1	X	X	X	X	X
Buck5, Flyback on	0	1	1	X	X	X	X	X
All On	1	1	1	X	X	X	X	X

Notes:

- 1. Positive logic level is used.
- 2. X: don't care.

SMBUS ELECTRICAL SPECIFICATION (Test Conditions: V+ = 5.5 V to 30 V, T _A = 0 °C)				
Symbol	Parameter	Min	Max	Units
V _{IL}	Data, Clock Input Low Voltage	- 0.5	0.6	V
V _{IH}	Data, Clock Input High Voltage	1.4	5.5	
V _{OL}	Data, Clock Output Low Voltage		0.4	
I _{LEAK}	Input Leakage		± 1	µA

SMBUS AC SPECIFICATIONS				
Symbol	Parameter	Min	Max	Units
F _{SMB}	SMBus Operation Frequency	10	100	kHz
T _{BUF}	Bus free time between Stop and Start	4.7		µs
T _{HD}	Data Hold Time	300		ns
T _{SU}	Data Setup Time	250		
T _{LOW}	Clock Low Period	4.7		µs
T _{HIGH}	Clock High Period	4.0	50	
T _F	Clock/Data Fall Time		300	ns
T _R	Clock/Data Rise Time		1000	

TIMING DIAGRAMS

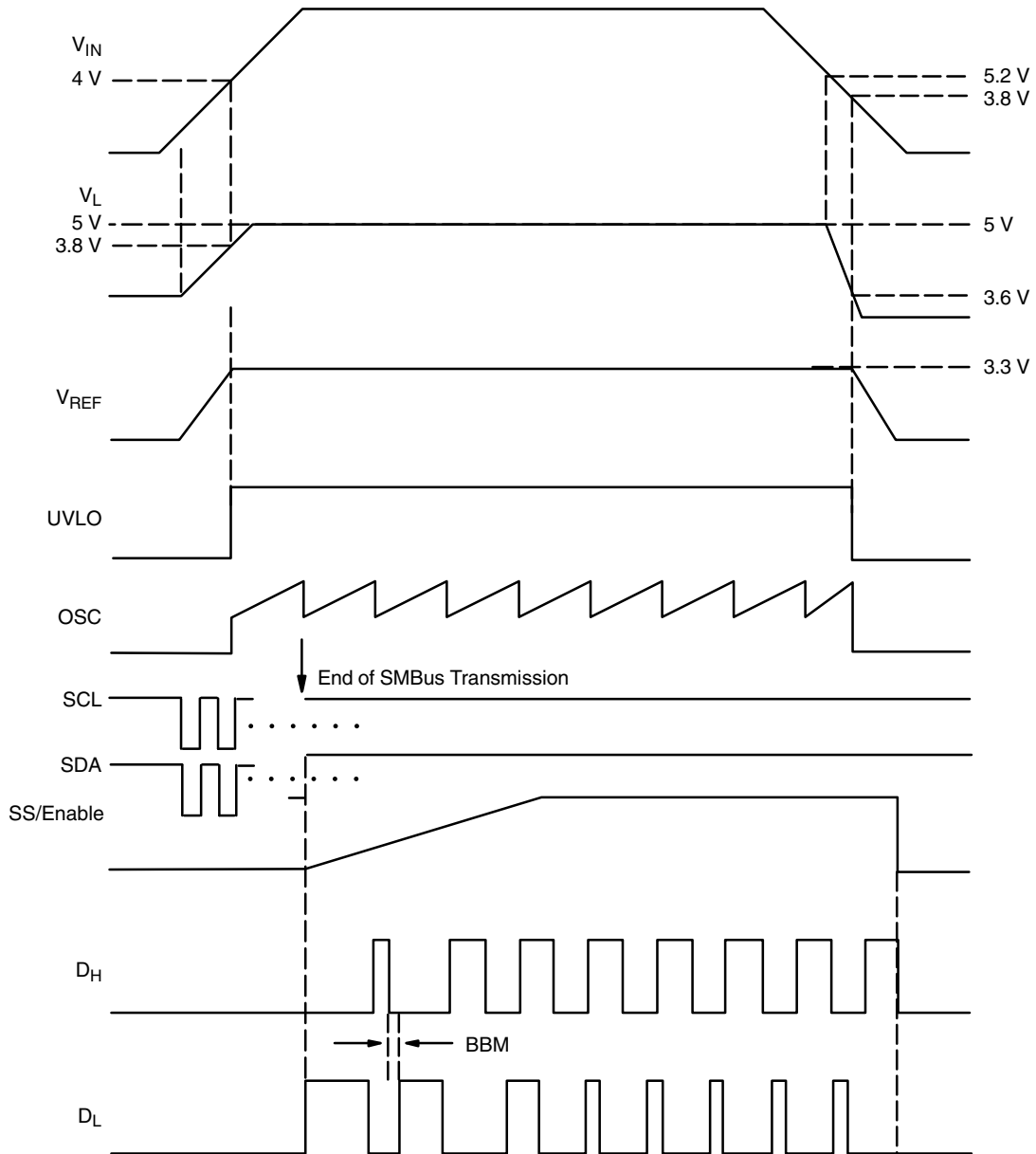
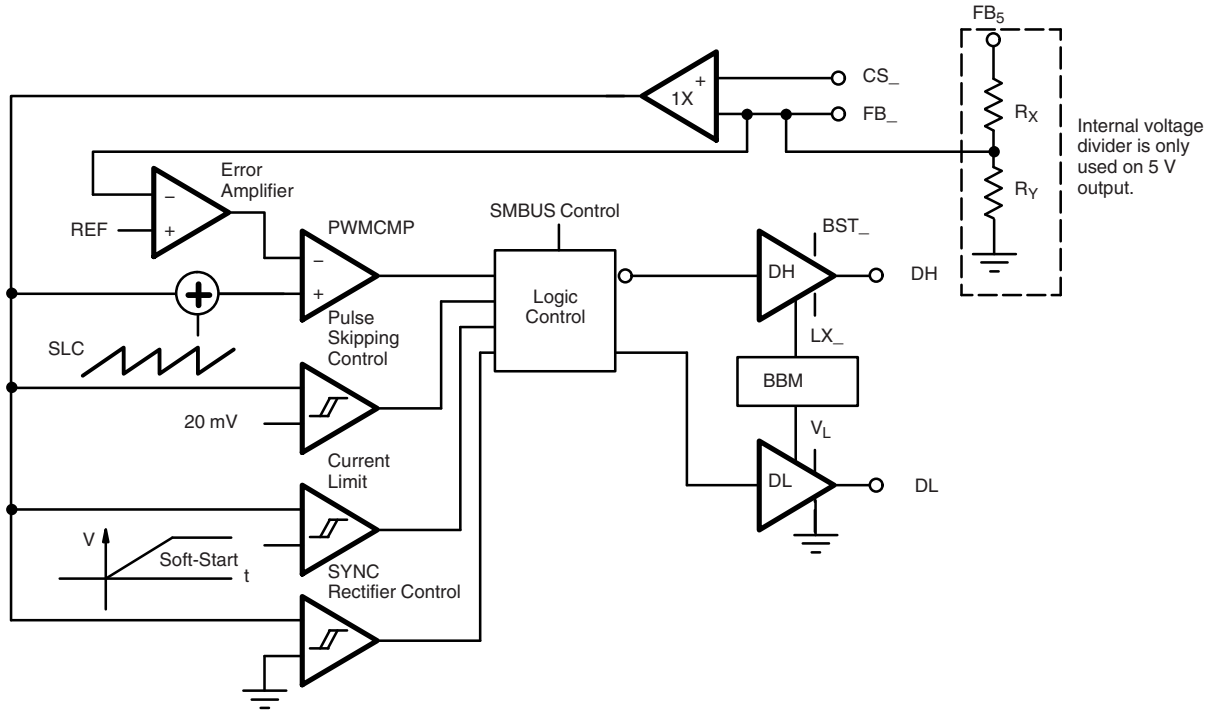
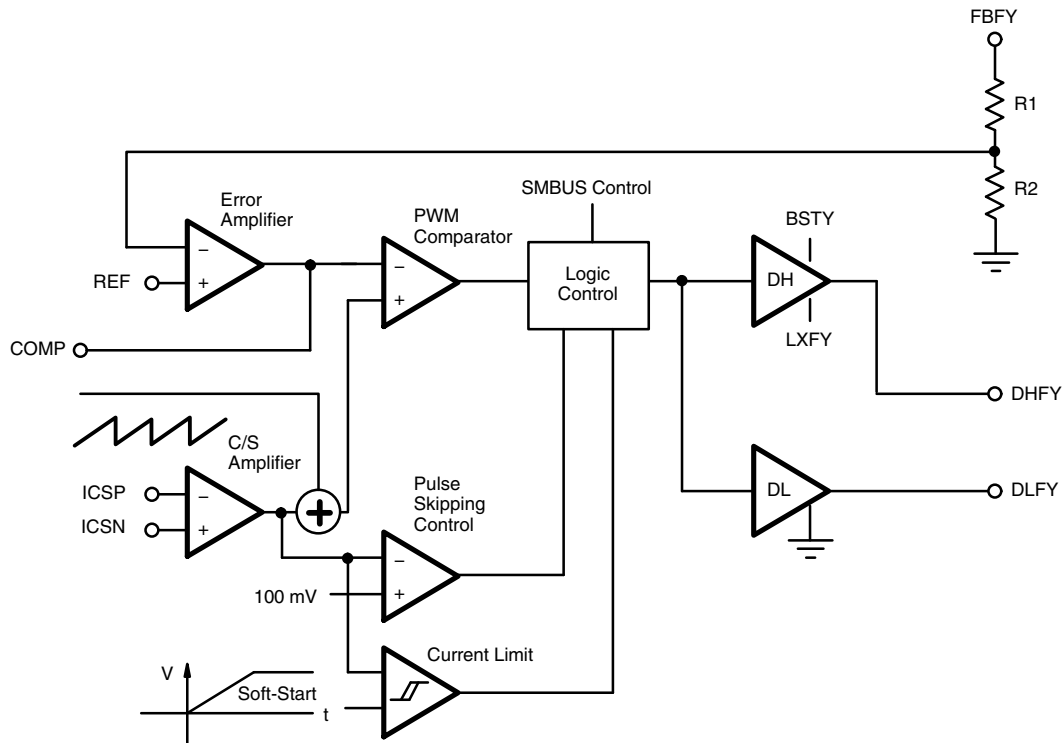

Figure 2. Start-Up Timing Sequence

DETAILED FUNCTIONAL BLOCK DIAGRAMS

Figure 3. Buck Block Diagram

Figure 4. PWM Flyback Block Diagram

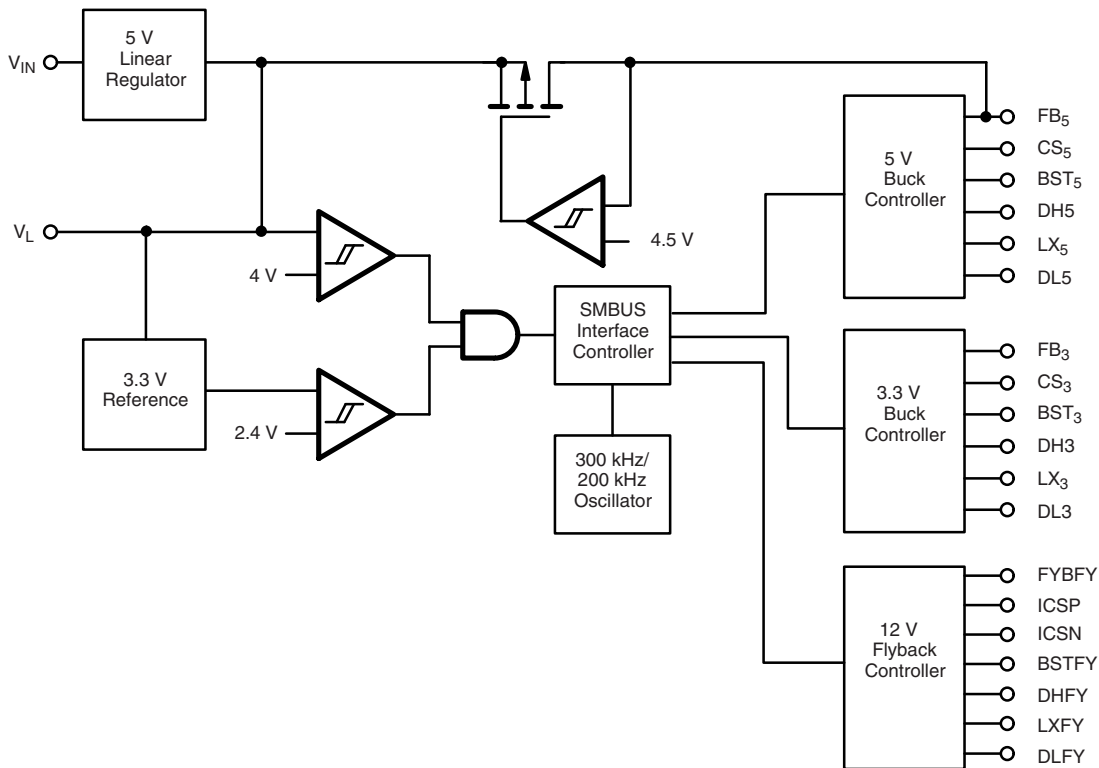

Figure 5. Complete Si9135 Block Diagram

DESCRIPTION OF OPERATION

Start-up Sequence

Si9135 is normally controlled by its SMBus interface after V_{IN} is applied. Initially, if there is no incoming SMBus control command, it comes up in its default power on sequence, first the LDO 5 V will come up within its tolerance, and then the precision 3.3 V reference will come up. Immediately afterwards, the oscillator will begin and 3.3 V BUCK converter will turn on and then 5 V BUCK converter and at last 12 V FLYBACK converter. If Si9135 receives any SMBus controlling command after LDO 5 V is established, the designated converters will be allowed to turn on or off independently depending on the command received. In the event of all three converters are turned off, the oscillator will be turned off, the total system would only draw 35 μ A supply current.

Each converter can soft-start separately. The integrated internal soft-start circuitry for each converter gradually increases the inductor maximum peak current during soft-start period (approximately 4 msec), preventing excessive

currents being drawn from the input during startup. The soft-start is controlled by initial default start up sequence or incoming SMBus command.

Si9135 converts a 5.5 V to 30 V input voltage to five outputs, two BUCK (step-down) high current, PWM, switch-mode supplies, one at 3.3 V and one at 5 V, one FLYBACK 12 V PWM switch-mode supply, one precision 3.3 V reference and one 5 V Low Drop Out linear regulator output. Switch-mode supply output current capabilities depend on external components (can exceed 10 A). With typical application shown on the application diagram, the two BUCK converters deliver 4 A and the FLYBACK converters deliver 0.25 A. The recommended load current for precision 3.3 V reference output is less than 1 mA, the recommended load current for 5 V LDO output current is less than 30 mA. In order to maximize the power efficiency, when the 5 V BUCK converter supply is above 4.5 V, the BUCK converter's output is internal connected to LDO output.



DESCRIPTION OF OPERATION (CONT'D)

Buck Converter Operation

The 3.3 V and 5 V buck converters are both current-mode PWM and PSM (during light load operation) regulators using high-side bootstrap N-Channel and low-side N-Channel MOSFETs. At light load conditions, the converters switch at a lower frequency than the clock frequency, seen like some clock pulses between the actual switching are skipped, this operating condition is defined as pulse-skipping. The operation of the converter(s) switching at clock frequency is defined as normal operation.

Normal Operation: Buck Converters

In normal operation, the buck converter high-side MOSFET is turned on with a delay (known as break-before-make time - t_{BBM}), after the rising edge of the clock. After a certain on time, the high-side MOSFET is turned off and then after a delay (t_{BBM}), the low-side MOSFET is turned on until the next rising edge of the clock, or the inductor current reaches zero. The t_{BBM} (approximately 25 ns to 60 ns), has been optimized to guarantee the efficiency is not adversely affected at the high switching frequency and a specified minimum to account for variations of possible MOSFET gate capacitances.

During the normal operation, the high-side MOSFET switch on-time is controlled internally to provide excellent line and load regulation over temperature. Both buck converters should have load, line, regulation to within 0.5 % tolerance.

Pulse Skipping: Buck Converters

When the buck converter switching frequency is less than the internal clock frequency, its operation mode is defined as pulse skipping mode. During this mode, the high-side MOSFET is turned on until $V_{CS} - V_{FB}$ reaches 20 mV, or the on time reaches its maximum duty ratio. After the high-side MOSFET is turned off, the low-side MOSFET is turned on after the t_{BBM} delay, which will remain on until the inductor current reaches zero. The output voltage will rise slightly above the regulation voltage after this sequence, causing the controller to stay idle for the next one, or several clock cycles. When the output voltage falls slightly below the regulation level, the high-side MOSFET will be turned on again at the next clock cycle. With the converter remaining idle during some clock cycles, the switching losses are reduced in order to preserve conversion efficiency during the light output current condition.

Current Limit: Buck Converters

When the buck converter inductor current is too high, the voltage across pin CS3(5) and pin FB3(5) exceeds approximately 120 mV, the high-side MOSFET would be turned off instantaneously regardless of the input, or output condition. The Si9135 features clock cycle by clock cycle current limiting capability.

Flyback Converter Operation

Designed mainly for PCMCIA or EEPROM programming, the Si9135 has a 12 V output non-isolated buck boost converter, called for brevity a flyback. It consists of two N-Channel MOSFET switches that are turned on and off in phase, and two diodes. Similar to the buck converter, during the light load conditions, the flyback converter will switch at a frequency lower than the internal clock frequency, which can be defined as pulse skipping mode (PSM); otherwise, it is operating in normal PWM mode.

Normal Operation: Flyback Converter

In normal operation mode, the two MOSFETs are turned on at the rising edge of the clock, and then turned off. The on time is controlled internally to provide excellent load, line, and temperature regulation. The flyback converter has load, line and temperature regulation well within 0.5 %.

Pulse Skipping: Flyback Converter

Under the light load conditions, similar to the buck converter, the flyback converter will enter pulse skipping mode. The MOSFETs will be turned on until the inductor current increases to such a level that the voltage across the pin CSP and pin CSN reaches 100 mV, or the on time reaches the maximum duty cycle. After the MOSFETs are turned off, the inductor current will conduct through two diodes until it reaches zero. At this point, the flyback converter output will rise slightly above the regulation level, and the converter will stay idle for one or several clock cycle(s) until the output falls back slightly below the regulation level. The switching losses are reduced by skipping pulses and so the efficiency during light load is preserved.

Current Limit: Flyback Converter

Similar to the buck converter; when the voltage across pin CSP and pin CSN exceeds 410 mV typical, the two MOSFETs will be turned off regardless of the input and output conditions.

DESCRIPTION OF OPERATION (CONT'D)

SMBus Commands

individually or as a group commanded on or off using a code word on the SMBus, as detailed in the SMBus Truth Table. The command sequence is:

1. Receive a start bit, which is a falling edge on the SDA line while the SCL line is high.
2. Receive a one-byte address, which for Si9135 is 01100000.
3. Send an acknowledge bit.
4. Receive a one-byte command.
5. Send an acknowledge bit.
6. Receive a stop bit, which is a rising edge on the SDA line while the SCL line is high.

This is a total of 20 bits, which at the maximum clock frequency of 100 kHz translates into 200 μ sec before any change in the status of Si9135 can be accomplished.

If Si9135 receives a command to turn on (respectively, off) a converter that is already on (respectively, off) it shall not falsely command the converter off (respectively, on).

Si9135 must be able to receive a stop command at any time during a command sequence. If Si9135 receives a stop command during a command sequence, it must not change the state of any converter, and must be ready to receive the next command sequence.

Grounding

There are two separate grounds on the Si9135, analog signal ground (GND) and power ground (PGND). The purpose of two separate grounds is to prevent the high currents on the power devices (both external and internal) from interfering with the analog signals. The internal components of Si9135 have their grounds tied (internally) together. These two grounds are then tied together (externally) at a single point, to ensure Si9135 noise immunity.

This separation of grounds should be maintained in the external circuitry, with the power ground of all power devices being returned directly to the input capacitors, and the small signal ground being returned to the GND pin of Si9135.

ON/OFF Function

Logic-low shuts off the appropriate section by disabling the gate drive stage. High-side and low-side gate drivers are turned off when ON/OFF pins are logic-low. Logic-high enables the DH and DL pins.

Stability

Buck Converters:

In order to simplify designs, the Si9135 requires no specified external components except load capacitors for stability control. Meanwhile, it achieves excellent regulation and efficiency. The converters are current mode control, with a bandwidth substantially higher than the LC tank dominant pole frequency of the output filter. To ensure stability, the minimum capacitance and maximum ESR values are:

$$C_{LOAD} \geq \frac{V_{REF}}{2\pi \times V_{OUT} \times R_{CS} \times BW} \quad ESR \leq \frac{V_{OUT} \times R_{CS}}{V_{REF}}$$

Where $V_{REF} = 3.3$ V, V_{OUT} is the output voltage (5 V or 3.3 V), R_{CS} is the current sensing resistor in ohms and $BW = 50$ kHz.

With the components specified in the application circuit ($L = 10$ μ H, $R_{CS} = 0.02$ Ω , $C_{OUT} = 330$ μ F, ESR approximately 0.1 Ω , the converter should have a bandwidth at approximately 50 kHz, with minimum phase margin of 65°, and dc gain above 50 dB.

Other Outputs

The Si9135 also provides a 3.3 V reference which can be external loaded up to 1 mA, as well as, a 5 V LDO output which can be loaded 30 mA, or even more depending on the system application. When the 5 V buck converter is turned on, the 5 V LDO output is shorted with the 5 V buck converter output, so its loading capability is substantially increased. For stability, the 3.3 V reference output requires a 1 μ F capacitor, and 5 V LDO output requires a 4.7 μ F capacitor.

Vishay Siliconix maintains worldwide manufacturing capability. Products may be manufactured at one of several qualified locations. Reliability data for Silicon Technology and Package Reliability represent a composite of all qualified locations. For related documents such as package/tape drawings, part marking, and reliability data, see www.vishay.com/ppg?70817.

SSOP: 28-LEAD (5.3 MM) (POWER IC ONLY)

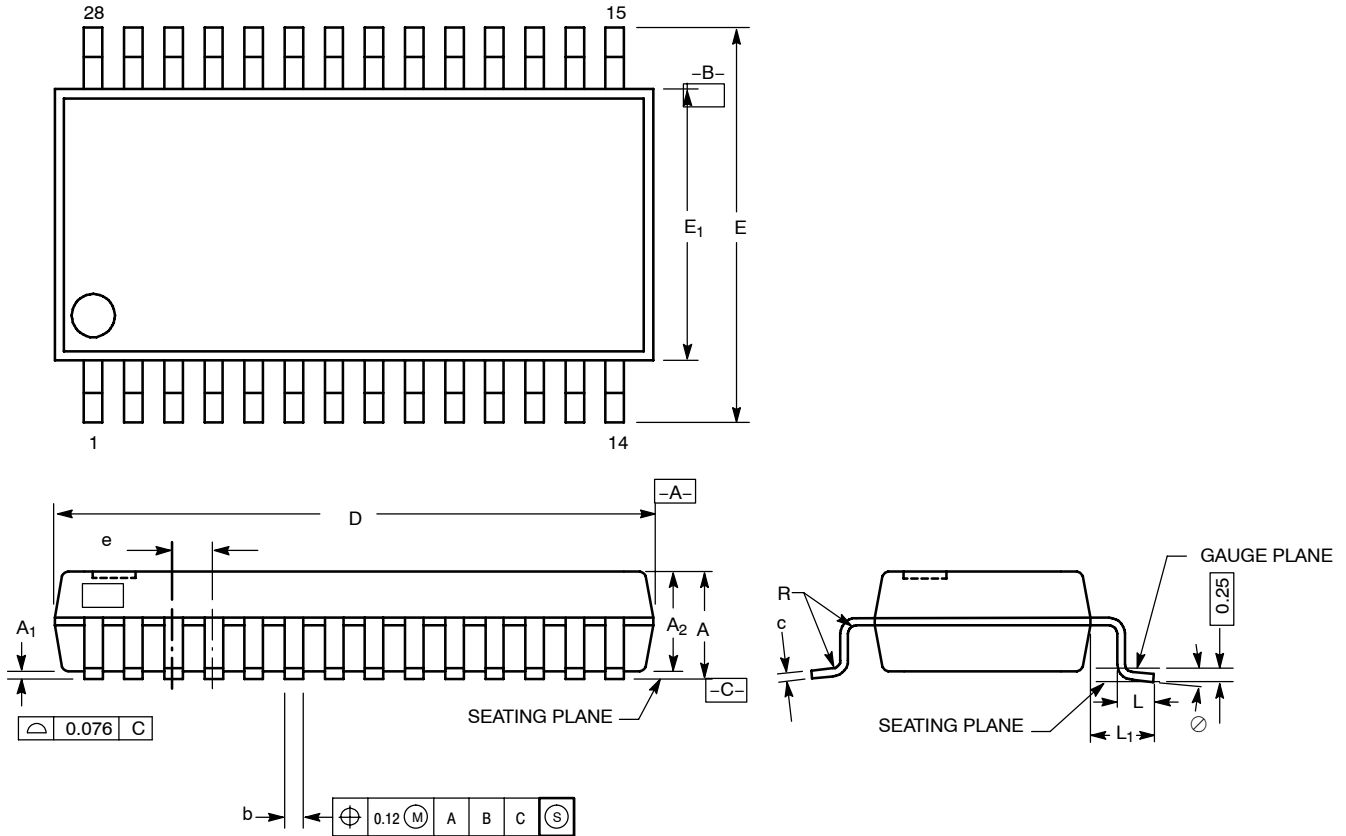

Dim	MILLIMETERS		
	Min	Nom	Max
A	1.73	1.88	1.99
A ₁	0.05	0.13	0.21
A ₂	1.68	1.75	1.78
b	0.25	0.30	0.38
c	0.09	0.15	0.20
D	10.07	10.20	10.33
E	7.60	7.80	8.00
E ₁	5.20	5.30	5.40
e	0.65 BSC		
L	0.63	0.75	0.95
L ₁	1.25 BSC		
R	0.09	0.15	---
∅	0°	4°	8°

ECN: S-40080—Rev. A, 02-Feb-04
DWG: 5915



Disclaimer

ALL PRODUCT, PRODUCT SPECIFICATIONS AND DATA ARE SUBJECT TO CHANGE WITHOUT NOTICE TO IMPROVE RELIABILITY, FUNCTION OR DESIGN OR OTHERWISE.

Vishay Intertechnology, Inc., its affiliates, agents, and employees, and all persons acting on its or their behalf (collectively, "Vishay"), disclaim any and all liability for any errors, inaccuracies or incompleteness contained in any datasheet or in any other disclosure relating to any product.

Vishay makes no warranty, representation or guarantee regarding the suitability of the products for any particular purpose or the continuing production of any product. To the maximum extent permitted by applicable law, Vishay disclaims (i) any and all liability arising out of the application or use of any product, (ii) any and all liability, including without limitation special, consequential or incidental damages, and (iii) any and all implied warranties, including warranties of fitness for particular purpose, non-infringement and merchantability.

Statements regarding the suitability of products for certain types of applications are based on Vishay's knowledge of typical requirements that are often placed on Vishay products in generic applications. Such statements are not binding statements about the suitability of products for a particular application. It is the customer's responsibility to validate that a particular product with the properties described in the product specification is suitable for use in a particular application. Parameters provided in datasheets and/or specifications may vary in different applications and performance may vary over time. All operating parameters, including typical parameters, must be validated for each customer application by the customer's technical experts. Product specifications do not expand or otherwise modify Vishay's terms and conditions of purchase, including but not limited to the warranty expressed therein.

Except as expressly indicated in writing, Vishay products are not designed for use in medical, life-saving, or life-sustaining applications or for any other application in which the failure of the Vishay product could result in personal injury or death. Customers using or selling Vishay products not expressly indicated for use in such applications do so at their own risk and agree to fully indemnify and hold Vishay and its distributors harmless from and against any and all claims, liabilities, expenses and damages arising or resulting in connection with such use or sale, including attorneys fees, even if such claim alleges that Vishay or its distributor was negligent regarding the design or manufacture of the part. Please contact authorized Vishay personnel to obtain written terms and conditions regarding products designed for such applications.

No license, express or implied, by estoppel or otherwise, to any intellectual property rights is granted by this document or by any conduct of Vishay. Product names and markings noted herein may be trademarks of their respective owners.

Компания «Океан Электроники» предлагает заключение долгосрочных отношений при поставках импортных электронных компонентов на взаимовыгодных условиях!

Наши преимущества:

- Поставка оригинальных импортных электронных компонентов напрямую с производств Америки, Европы и Азии, а так же с крупнейших складов мира;
- Широкая линейка поставок активных и пассивных импортных электронных компонентов (более 30 млн. наименований);
- Поставка сложных, дефицитных, либо снятых с производства позиций;
- Оперативные сроки поставки под заказ (от 5 рабочих дней);
- Экспресс доставка в любую точку России;
- Помощь Конструкторского Отдела и консультации квалифицированных инженеров;
- Техническая поддержка проекта, помощь в подборе аналогов, поставка прототипов;
- Поставка электронных компонентов под контролем ВП;
- Система менеджмента качества сертифицирована по Международному стандарту ISO 9001;
- При необходимости вся продукция военного и аэрокосмического назначения проходит испытания и сертификацию в лаборатории (по согласованию с заказчиком);
- Поставка специализированных компонентов военного и аэрокосмического уровня качества (Xilinx, Altera, Analog Devices, Intersil, Interpoint, Microsemi, Actel, Aeroflex, Peregrine, VPT, Syfer, Eurofarad, Texas Instruments, MS Kennedy, Miteq, Cobham, E2V, MA-COM, Hittite, Mini-Circuits, General Dynamics и др.);

Компания «Океан Электроники» является официальным дистрибьютором и эксклюзивным представителем в России одного из крупнейших производителей разъемов военного и аэрокосмического назначения «JONHON», а так же официальным дистрибьютором и эксклюзивным представителем в России производителя высокотехнологичных и надежных решений для передачи СВЧ сигналов «FORSTAR».



JONHON

«JONHON» (основан в 1970 г.)

Разъемы специального, военного и аэрокосмического назначения:

(Применяются в военной, авиационной, аэрокосмической, морской, железнодорожной, горно- и нефтедобывающей отраслях промышленности)

«FORSTAR» (основан в 1998 г.)

ВЧ соединители, коаксиальные кабели,
кабельные сборки и микроволновые компоненты:

(Применяются в телекоммуникациях гражданского и специального назначения, в средствах связи, РЛС, а так же военной, авиационной и аэрокосмической отраслях промышленности).



Телефон: 8 (812) 309-75-97 (многоканальный)

Факс: 8 (812) 320-03-32

Электронная почта: ocean@oceanchips.ru

Web: <http://oceanchips.ru/>

Адрес: 198099, г. Санкт-Петербург, ул. Калинина, д. 2, корп. 4, лит. А