

## LT8302 Isolated Triple Output 5V, $\pm 15V$ Flyback Converter

### DESCRIPTION

Demonstration circuit 2906A is an isolated triple output flyback converter featuring the [LT<sup>®</sup>8302](#). The DC2906A operates over a wide input voltage range of 4.5V to 28V and samples the primary-side flyback waveform to regulate the secondary side output voltages. It generates three isolated output rails: 5V at 400mA+ and  $\pm 15V$  at 100mA+. Line and load regulation (combined) is within  $\pm 10\%$ .

DC2906A showcases the high power density, high efficiency and good regulation that is possible due to the LT8302's high level of integration. Figure 3 and Figure 4 show the efficiency curves, while Figures 5 through 7, and

Table 1 demonstrate the output voltage regulation under different load and line conditions.

The Performance Summary table summarizes the performance of the demo board at room temperature.

The LT8302 datasheet gives a complete description of the part, operation and application information. The datasheet must be read in conjunction with this quick start guide for demo circuit 2906A.

[Design files for this circuit board are available.](#)

All registered trademarks and trademarks are the property of their respective owners.

### PERFORMANCE SUMMARY Specifications are at $T_A = 25^\circ C$

PARAMETER	CONDITIONS	MIN	TYP	MAX	UNITS
Input Voltage		4.5	24	28	V
Output Voltage	V01 (5V) V02 (-15V) V03 (15V)	4.75 -16.3 14.3		5.75 -14.3 16.3	V V V
Output Voltage Ripple (Peak to Peak)	V01 (5V), 20 MHz Bandwidth V02 (-15V), 20 MHz Bandwidth V03 (15V), 20 MHz Bandwidth		50 150 150		mV mV mV
Efficiency	$V_{IN} = 5V$ , Full Load $V_{IN} = 12V$ , Full Load $V_{IN} = 24V$ , Full Load		82.8 86.5 85.3		% % %

## QUICK START PROCEDURE

Demonstration circuit 2906A is easy to set up to evaluate the performance of the LT8302. Refer to Figure 1 for proper measurement equipment setup and follow the procedure below:

1. With power off, connect the input power supply to the board through the  $V_{IN}$  and  $-V_{IN}$  terminals. Connect the loads to the terminals VO1-GND1(5V), VO2-GND2(-15V) and VO3-GND3(15V) on the board.
2. Turn on the power at the input. Increase the input voltage slowly to 4.5V.

NOTE: Make sure that the input voltage is always within spec. To operate the board with higher input/output voltages, a higher voltage rating input capacitor, output capacitor and output diode might be needed.

3. Check for the proper output voltages. The output should be regulated at 5V, 15V and -15V (with allowable tolerance of  $\pm 10\%$ ) with respect to GND.

NOTE: The LT8302 requires very small minimum load to maintain good output voltage regulation. A zener diode is placed on each output to clamp the output voltage.

4. Once the proper output voltage is established, adjust the input voltage and load current within the operating range and observe the output voltage regulation, ripple voltage, efficiency and other parameters.

NOTE: When measuring the input or output voltage ripples, care must be taken to avoid a long ground lead on the oscilloscope probe. Measure the input or output voltage ripple by touching the probe tip directly across the  $V_{IN}$  and  $-V_{IN}$ , or output side terminals. See Figure 2 for proper scope probe technique.

**QUICK START PROCEDURE**

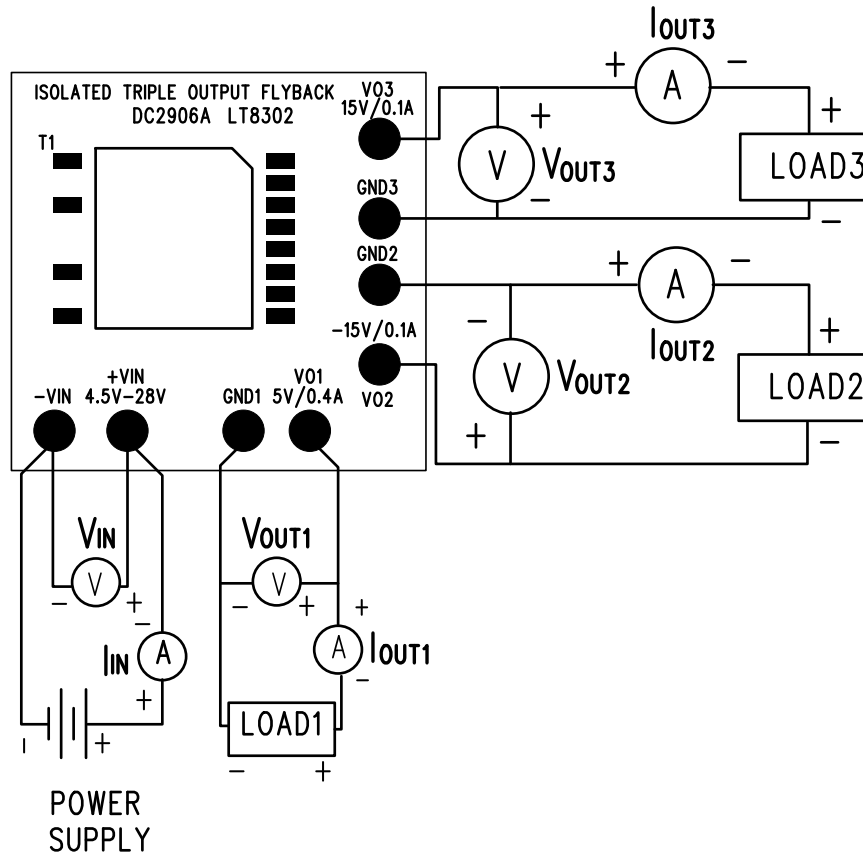

DC2906A-2.pcb - Fri Dec 14 10:45:50 2018

**Figure 1. Proper Measurement Equipment Setup**

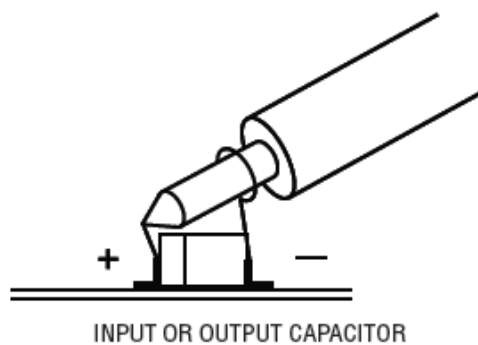

**Figure 2. Proper Scope Probe Placement for Measuring Input or Output Ripple**

## QUICK START PROCEDURE

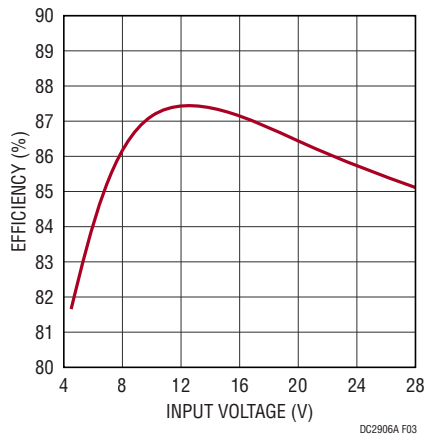

Figure 3. Full Load Efficiency vs. Input Voltage

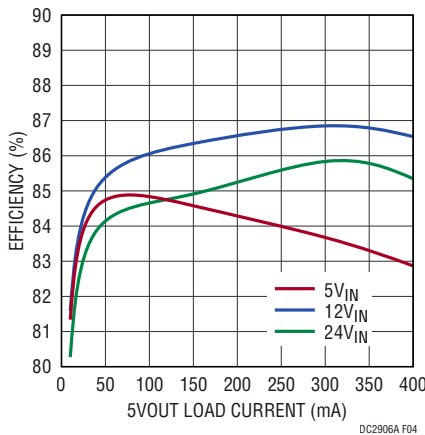

Figure 4. Efficiency vs. 5V<sub>OUT</sub> Load Current with Different Input Voltages (0A – 0.4A on 5V<sub>OUT</sub>, Full Load on ±15V<sub>OUT</sub>)

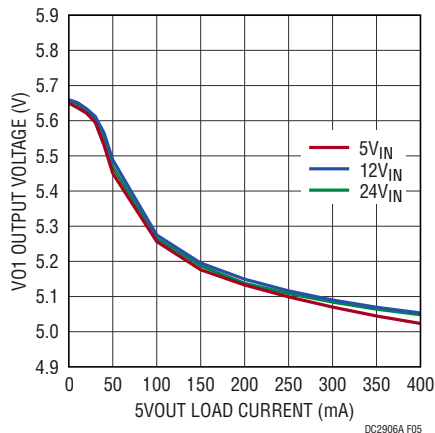
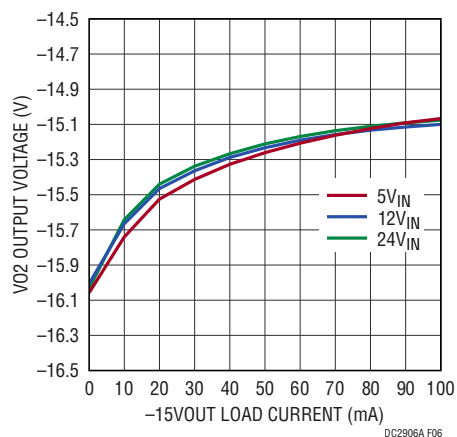
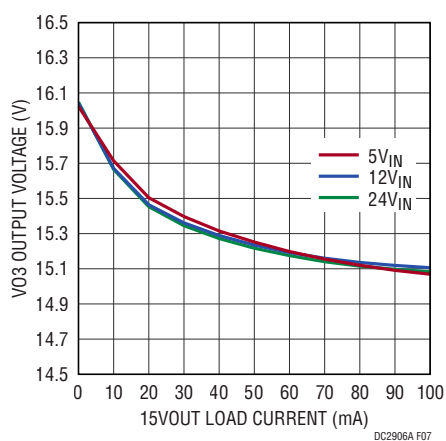

Figure 5. V01 Output Voltage vs. Load Current with Different Input Voltages (0A – 0.4A on 5V<sub>OUT</sub>, Full Load on ±15V<sub>OUT</sub>)

## QUICK START PROCEDURE



**Figure 6. V02 Output Voltage vs. Load Current with Different Input Voltages (0A – 0.1A on -15V<sub>OUT</sub>, Full Load on 5V<sub>OUT</sub> and 15V<sub>OUT</sub>)**



**Figure 7. V03 Output Voltage vs. Load Current with Different Input Voltages (0A – 0.1A on 15V<sub>OUT</sub>, Full Load on 5V<sub>OUT</sub> and -15V<sub>OUT</sub>)**

**Table 1. Full Load Output Voltage vs. Input Voltage**

	V01 = 5V	V02 = -15V	V03 = 15V
Min.	5.010V	-15.102V	15.066V
Max.	5.054V	-15.060V	15.112V

# DEMO MANUAL DC2906A

## PARTS LIST

ITEM	QTY	REFERENCE	PART DESCRIPTION	MANUFACTURER/PART NUMBER
<b>Required Circuit Components</b>				
1	2	C1, C8	CAP, 10uF, X7R, 50V, 10%, 1210	MURATA, GRM32ER71H106KA12L
2	1	C2	CAP, 1uF, X7R, 50V, 10%, 0603	AVX, 06035C105KAT2A
3	1	C3	CAP, 1uF, X7R, 50V, 10%, 1206	AVX, 12065C105KAT2A
4	1	C4	CAP, 270pF, C0G, 100V, 5%, 0603	AVX, 06031A271JAT2A
5	2	C5, C6	CAP, 22uF, X7R, 25V, 10%, 1210	AVX, 12103C226KAT2A
6	1	C7	CAP, 100uF, X5R, 10V, 20%, 1210	KEMET, C1210C107M8PACTU
7	1	D1	DIODE, TVS, SINGLE, UNI-DIRECT, 24V, 400W, SMA	DIODES INC., SMAJ24A-13-F
8	1	D2	DIODE, SCHOTTKY, 100V, 1A, SOD-123W, AEC-Q101	NEXPERIA, PMEG10010ELR
9	2	D3, D4	DIODE, SWITCHING, 100V, 250mW, SOD-123	DIODES INC., BAV19W-7-F
10	1	D5	DIODE, SCHOTTKY, 60V, 3A, SOD-128, AEC-Q101	NEXPERIA, PMEG6030EP, 115
11	2	D6, D7	DIODE, ZENER, 16V, 590mW, SOD-123, AEC-Q101	NEXPERIA, BZT52-B16J
12	1	D8	DIODE, ZENER, 5.6V, 590mW, SOD-123, AEC-Q101	NEXPERIA, BZT52-B5V6J
13	1	R1	RES., 0 OHM, 1/10W, 0603, AEC-Q200	VISHAY, CRCW06030000Z0EA
14	1	R3	RES., 49.9 OHMS, 1%, 1/4W, 1206, AEC-Q200	NIC, NRC12F49R9TRF
15	1	R4	RES., 154k OHMS, 1%, 1/10W, 0603	VISHAY, CRCW0603154KFKEA
16	1	R5	RES., 10k OHMS, 1%, 1/8W, 0603, AEC-Q200	VISHAY, TNPW060310K0BEEA
17	1	T1	XFMR, FLYBACK, 15.2 x 14.0mm SMD	SUMIDA, PS18-195
18	1	U1	IC, Isolated Flyback Converter, SOIC-8	ANALOG DEVICES, LT8302ES8E#PBF
<b>HARDWARE: FOR DEMOBOARD ONLY</b>				
1	8	E1, E2, E3	TEST POINT, TURRET, 0.064", MTG. HOLE	MILL-MAX, 2308-2-00-80-00-00-07-0
<b>OPTIONAL CIRCUIT COMPONENTS</b>				
1	0	R2	RES., OPTION, 0603	

**SCHEMATIC DIAGRAM**

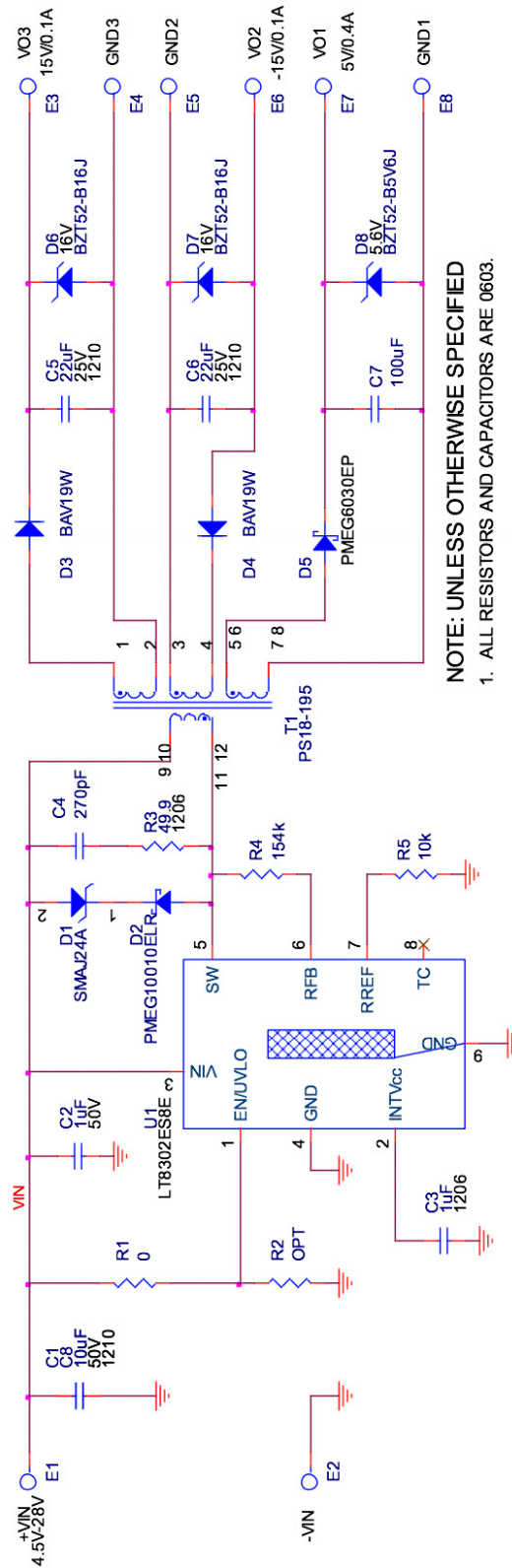

**NOTE: UNLESS OTHERWISE SPECIFIED**  
 1. ALL RESISTORS AND CAPACITORS ARE 0603.



## ESD Caution

**ESD (electrostatic discharge) sensitive device.** Charged devices and circuit boards can discharge without detection. Although this product features patented or proprietary protection circuitry, damage may occur on devices subjected to high energy ESD. Therefore, proper ESD precautions should be taken to avoid performance degradation or loss of functionality.

## Legal Terms and Conditions

By using the evaluation board discussed herein (together with any tools, components documentation or support materials, the "Evaluation Board"), you are agreeing to be bound by the terms and conditions set forth below ("Agreement") unless you have purchased the Evaluation Board, in which case the Analog Devices Standard Terms and Conditions of Sale shall govern. Do not use the Evaluation Board until you have read and agreed to the Agreement. Your use of the Evaluation Board shall signify your acceptance of the Agreement. This Agreement is made by and between you ("Customer") and Analog Devices, Inc. ("ADI"), with its principal place of business at One Technology Way, Norwood, MA 02062, USA. Subject to the terms and conditions of the Agreement, ADI hereby grants to Customer a free, limited, personal, temporary, non-exclusive, non-sublicensable, non-transferable license to use the Evaluation Board FOR EVALUATION PURPOSES ONLY. Customer understands and agrees that the Evaluation Board is provided for the sole and exclusive purpose referenced above, and agrees not to use the Evaluation Board for any other purpose. Furthermore, the license granted is expressly made subject to the following additional limitations: Customer shall not (i) rent, lease, display, sell, transfer, assign, sublicense, or distribute the Evaluation Board; and (ii) permit any Third Party to access the Evaluation Board. As used herein, the term "Third Party" includes any entity other than ADI, Customer, their employees, affiliates and in-house consultants. The Evaluation Board is NOT sold to Customer; all rights not expressly granted herein, including ownership of the Evaluation Board, are reserved by ADI. CONFIDENTIALITY. This Agreement and the Evaluation Board shall all be considered the confidential and proprietary information of ADI. Customer may not disclose or transfer any portion of the Evaluation Board to any other party for any reason. Upon discontinuation of use of the Evaluation Board or termination of this Agreement, Customer agrees to promptly return the Evaluation Board to ADI. ADDITIONAL RESTRICTIONS. Customer may not disassemble, decompile or reverse engineer chips on the Evaluation Board. Customer shall inform ADI of any occurred damages or any modifications or alterations it makes to the Evaluation Board, including but not limited to soldering or any other activity that affects the material content of the Evaluation Board. Modifications to the Evaluation Board must comply with applicable law, including but not limited to the RoHS Directive. TERMINATION. ADI may terminate this Agreement at any time upon giving written notice to Customer. Customer agrees to return to ADI the Evaluation Board at that time. LIMITATION OF LIABILITY. THE EVALUATION BOARD PROVIDED HEREUNDER IS PROVIDED "AS IS" AND ADI MAKES NO WARRANTIES OR REPRESENTATIONS OF ANY KIND WITH RESPECT TO IT. ADI SPECIFICALLY DISCLAIMS ANY REPRESENTATIONS, ENDORSEMENTS, GUARANTEES, OR WARRANTIES, EXPRESS OR IMPLIED, RELATED TO THE EVALUATION BOARD INCLUDING, BUT NOT LIMITED TO, THE IMPLIED WARRANTY OF MERCHANTABILITY, TITLE, FITNESS FOR A PARTICULAR PURPOSE OR NON-INFRINGEMENT OF INTELLECTUAL PROPERTY RIGHTS. IN NO EVENT WILL ADI AND ITS LICENSORS BE LIABLE FOR ANY INCIDENTAL, SPECIAL, INDIRECT, OR CONSEQUENTIAL DAMAGES RESULTING FROM CUSTOMER'S POSSESSION OR USE OF THE EVALUATION BOARD, INCLUDING BUT NOT LIMITED TO LOST PROFITS, DELAY COSTS, LABOR COSTS OR LOSS OF GOODWILL. ADI'S TOTAL LIABILITY FROM ANY AND ALL CAUSES SHALL BE LIMITED TO THE AMOUNT OF ONE HUNDRED US DOLLARS (\$100.00). EXPORT. Customer agrees that it will not directly or indirectly export the Evaluation Board to another country, and that it will comply with all applicable United States federal laws and regulations relating to exports. GOVERNING LAW. This Agreement shall be governed by and construed in accordance with the substantive laws of the Commonwealth of Massachusetts (excluding conflict of law rules). Any legal action regarding this Agreement will be heard in the state or federal courts having jurisdiction in Suffolk County, Massachusetts, and Customer hereby submits to the personal jurisdiction and venue of such courts. The United Nations Convention on Contracts for the International Sale of Goods shall not apply to this Agreement and is expressly disclaimed.



Компания «Океан Электроники» предлагает заключение долгосрочных отношений при поставках импортных электронных компонентов на взаимовыгодных условиях!

Наши преимущества:

- Поставка оригинальных импортных электронных компонентов напрямую с производств Америки, Европы и Азии, а так же с крупнейших складов мира;
- Широкая линейка поставок активных и пассивных импортных электронных компонентов (более 30 млн. наименований);
- Поставка сложных, дефицитных, либо снятых с производства позиций;
- Оперативные сроки поставки под заказ (от 5 рабочих дней);
- Экспресс доставка в любую точку России;
- Помощь Конструкторского Отдела и консультации квалифицированных инженеров;
- Техническая поддержка проекта, помощь в подборе аналогов, поставка прототипов;
- Поставка электронных компонентов под контролем ВП;
- Система менеджмента качества сертифицирована по Международному стандарту ISO 9001;
- При необходимости вся продукция военного и аэрокосмического назначения проходит испытания и сертификацию в лаборатории (по согласованию с заказчиком);
- Поставка специализированных компонентов военного и аэрокосмического уровня качества (Xilinx, Altera, Analog Devices, Intersil, Interpoint, Microsemi, Actel, Aeroflex, Peregrine, VPT, Syfer, Eurofarad, Texas Instruments, MS Kennedy, Miteq, Cobham, E2V, MA-COM, Hittite, Mini-Circuits, General Dynamics и др.);

Компания «Океан Электроники» является официальным дистрибьютором и эксклюзивным представителем в России одного из крупнейших производителей разъемов военного и аэрокосмического назначения «JONHON», а так же официальным дистрибьютором и эксклюзивным представителем в России производителя высокотехнологичных и надежных решений для передачи СВЧ сигналов «FORSTAR».



## JONHON

«JONHON» (основан в 1970 г.)

Разъемы специального, военного и аэрокосмического назначения:

(Применяются в военной, авиационной, аэрокосмической, морской, железнодорожной, горно- и нефтедобывающей отраслях промышленности)

«FORSTAR» (основан в 1998 г.)

ВЧ соединители, коаксиальные кабели, кабельные сборки и микроволновые компоненты:

(Применяются в телекоммуникациях гражданского и специального назначения, в средствах связи, РЛС, а так же военной, авиационной и аэрокосмической отраслях промышленности).



Телефон: 8 (812) 309-75-97 (многоканальный)

Факс: 8 (812) 320-03-32

Электронная почта: [ocean@oceanchips.ru](mailto:ocean@oceanchips.ru)

Web: <http://oceanchips.ru/>

Адрес: 198099, г. Санкт-Петербург, ул. Калинина, д. 2, корп. 4, лит. А