

NCS2563

3-Channel Video Amp with High Definition Reconstruction Filters

Description

NCS2563 is a 3-Channel high speed video amplifier with 6th order Butterworth High Definition (HD) reconstruction filters and 6 dB gain.

All three channels can accommodate all Component and RGB video signals. All channels can accept DC or AC coupled signals. If AC coupled, the internal clamps are employed. The outputs can drive both AC and DC coupled 150 Ω loads.

It is designed to be compatible with most Digital-to-Analog Converters (DAC) embedded in most video processors.

Features

- Three 6th Order High Definition 30 MHz Filter
- Internally Fixed Gain = 6 dB
- Transparent Input Clamping for Each Channel
- DC or AC Coupled Inputs
- DC or AC Coupled Outputs
- Integrated Level Shifter
- Operating Voltage +5 V
- Available in SOIC-8 Package
- These are Pb-Free Devices

Applications

- Digital Set-Top Box
- DVD and Video Players
- HDTV
- Video-On-Demand (VOD)



ON Semiconductor®

<http://onsemi.com>

MARKING DIAGRAM*

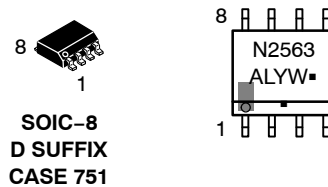

A = Assembly Location
L = Wafer Lot
Y = Year
W = Work Week
▪ = Pb-Free Package

(Note: Microdot may be in either location)

PINOUT

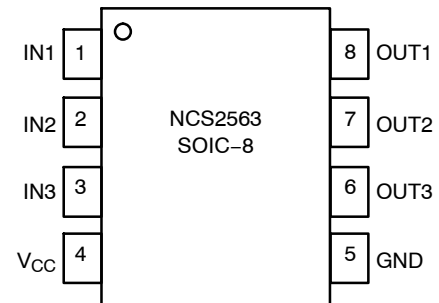

ORDERING INFORMATION

Device	Package	Shipping†
NCS2563DG	SOIC-8 (Pb-Free)	98 Units / Rail
NCS2563DR2G	SOIC-8 (Pb-Free)	2500 / Tape & Reel

†For information on tape and reel specifications, including part orientation and tape sizes, please refer to our Tape and Reel Packaging Specifications Brochure, BRD8011/D.

NCS2563

PIN FUNCTION AND DESCRIPTION

Pin	Name	Type	Description
1	IN1	Input	Video Input 1 for Video Signal featuring a frequency bandwidth compatible with High Definition Video (30 MHz) – Channel 1
2	IN2	Input	Video Input 2 for Video Signal featuring a frequency bandwidth compatible with High Definition Video (30 MHz) – Channel 2
3	IN3	Input	Video Input 3 for Video Signal featuring a frequency bandwidth compatible with High Definition Video (30 MHz) – Channel 3
4	VCC	Power	Device Power Supply Voltage: +5 V
5	GND	GND	Connected to Ground
6	OUT3	Output	HD Video Output 3 – Channel 3
7	OUT2	Output	HD Video Output 2 – Channel 2
8	OUT1	Output	HD Video Output 1 – Channel 1

ATTRIBUTES

Characteristics	Value
ESD Human Body Model Machine Model	All Pins (Note 1) Pins 1 to 5 (Note 2) All Output Pins (Note 2)
	8 kV 400 V 600 V
Moisture Sensitivity (Note 3)	Level 1
Flammability Rating – Oxygen Index: 28 to 34	UL 94 V-0 @ 0.125 in

1. Human Body Model (HBM): R = 1500 Ω , C = 100 pF
2. Machine Model (MM)
3. For additional information, see Application Note AND8003/D.

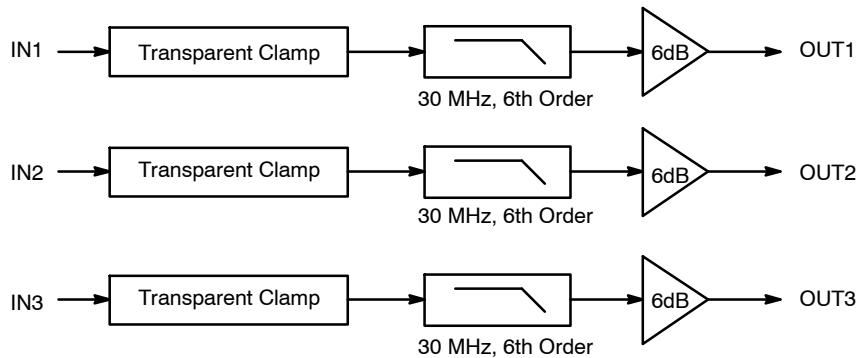

Figure 1. Block Diagram

MAXIMUM RATINGS

Parameter	Symbol	Rating	Unit
Power Supply Voltages	V_{CC}	$-0.35 \leq V_{CC} \leq 5.5$	Vdc
Input Voltage Range	V_I	$-0.3 \leq V_I \leq V_{CC}$	Vdc
Input Differential Voltage Range	V_{ID}	$V_I \leq V_{CC}$	Vdc
Output Current	I_O	50	mA
Maximum Junction Temperature (Note 4)	T_J	150	°C
Operating Ambient Temperature	T_A	-40 to +85	°C
Storage Temperature Range	T_{stg}	-60 to +150	°C
Power Dissipation	P_D	(See Graph)	mW
Thermal Resistance, Junction-to-Air	$R_{\theta JA}$	112.7	°C/W

Stresses exceeding Maximum Ratings may damage the device. Maximum Ratings are stress ratings only. Functional operation above the Recommended Operating Conditions is not implied. Extended exposure to stresses above the Recommended Operating Conditions may affect device reliability.

4. Power dissipation must be considered to ensure maximum junction temperature (T_J) is not exceeded.

Maximum Power Dissipation

The maximum power that can be safely dissipated is limited by the associated rise in junction temperature. For the plastic packages, the maximum safe junction temperature is 150°C. If the maximum is exceeded momentarily, proper circuit operation will be restored as soon as the die temperature is reduced. Leaving the device in the “overheated” condition for an extended period can result in device burnout. To ensure proper operation, it is important to observe the derating curves.

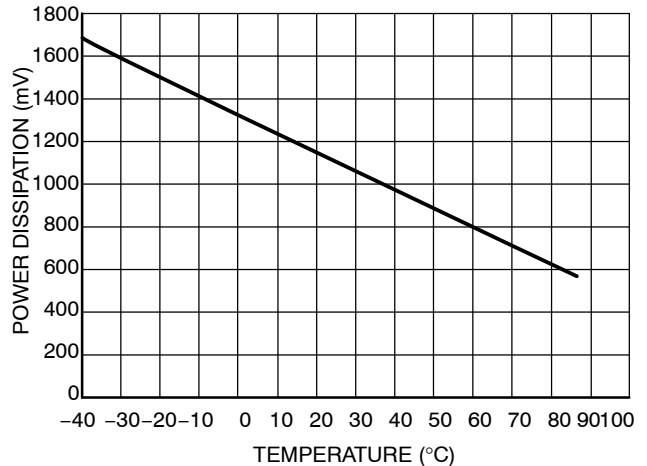

Figure 2. Power Dissipation vs Temperature

NCS2563

DC ELECTRICAL CHARACTERISTICS ($V_{CC} = +5.0\text{ V}$, $T_A = 25^\circ\text{C}$, $0.1\ \mu\text{F}$ AC coupled inputs, $R_{\text{source}} = 37.5\ \Omega$, $220\ \mu\text{F}$ AC coupled outputs into $150\ \Omega$ load, referenced to $400\ \text{kHz}$, unless otherwise specified)

Symbol	Characteristics	Conditions	Min	Typ	Max	Unit
V_{CC}	Operating Voltage Range		4.75	5	5.25	V
I_{CC}	Power Supply Current			22	33	mA
V_{IN}	Input Common Mode Voltage Range		GND		1.4	V
V_{OH}	Output High Voltage			2.8		V
V_{OL}	Output Low Voltage			280		mV

NOTE: Device will meet the specifications after thermal equilibrium has been established when mounted in a test socket or printed circuit board with maintained transverse airflow greater than $500\ \text{lfpm}$. Electrical parameters are guaranteed only over the declared operating temperature range. Functional operation of the device exceeding these conditions is not implied. Device specification limit values are applied individually under normal operating conditions and not valid simultaneously.

AC ELECTRICAL CHARACTERISTICS ($V_{CC} = +5.0\text{ V}$, $T_A = 25^\circ\text{C}$, $0.1\ \mu\text{F}$ AC coupled inputs, $R_{\text{source}} = 37.5\ \Omega$, $220\ \mu\text{F}$ AC coupled outputs into $150\ \Omega$ load, referenced to $400\ \text{kHz}$, unless otherwise specified)

Symbol	Characteristics	Conditions	Min	Typ	Max	Unit
A_{VOL}	Voltage Gain (Note 5)	$V_{IN} = 1\ \text{V}$	5.8	6.0	6.2	dB
BW	Bandwidth of Low Pass Filter	-1 dB -3 dB	23	30 33		MHz
A_R	Attenuation (Stopband Reject)	$f = 44.25\ \text{MHz}$ $f = 74.25\ \text{MHz}$	28	14.5 36		
dG	Differential Gain	$A_V = +2$, $R_L = 150\ \Omega$		0.2		%
dP	Differential Phase	$A_V = +2$, $R_L = 150\ \Omega$		0.1		°
THD	Total Harmonic Distortion	$V_{OUT} = 1.4\ V_{PP}$, $f = 10\ \text{MHz}$ $V_{OUT} = 1.4\ V_{PP}$, $f = 15\ \text{MHz}$ $V_{OUT} = 1.4\ V_{PP}$, $f = 22\ \text{MHz}$		0.2 0.4 1.2		%
x_{talk}	Channel-to-Channel Crosstalk	$V_{IN} = 1.4\ V_{PP}$, $f = 1\ \text{MHz}$		60		dB
SNR	Signal to Noise Ratio* (Note 6)	100% White Signal, 100 kHz to 30 MHz		65		dB
t_{PD}	Propagation Delay	Input to Output		20		ns
ΔT_g	Group Delay Variation*	100 kHz to 30 MHz		6		ns

NOTE: Device will meet the specifications after thermal equilibrium has been established when mounted in a test socket or printed circuit board with maintained transverse airflow greater than $500\ \text{lfpm}$. Electrical parameters are guaranteed only over the declared operating temperature range. Functional operation of the device exceeding these conditions is not implied. Device specification limit values are applied individually under normal operating conditions and not valid simultaneously.

*Guaranteed by design

5. 100% of tested IC fit to the bandwidth tolerance.
6. $\text{SNR} = 20 \times \log(714\ \text{mV/RMS noise})$

TYPICAL CHARACTERISTICS

$T_A = 25^\circ\text{C}$, $V_{CC} = 5\text{ V}$, $R_{\text{source}} = 37.5\ \Omega$, $0.1\ \mu\text{F}$ AC-Coupled Inputs, $220\ \mu\text{F}$ AC-Coupled Outputs with $150\ \Omega$

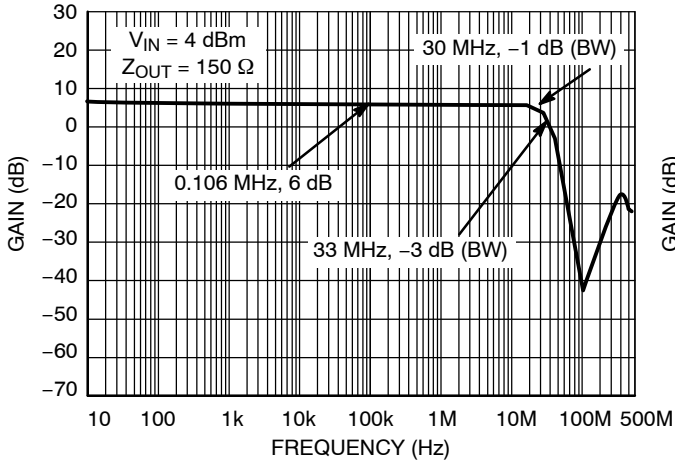

Figure 3. Gain vs. Frequency

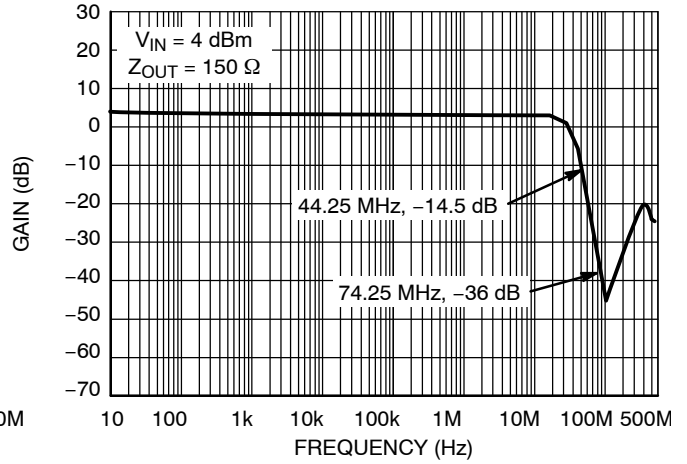

Figure 4. Attenuation

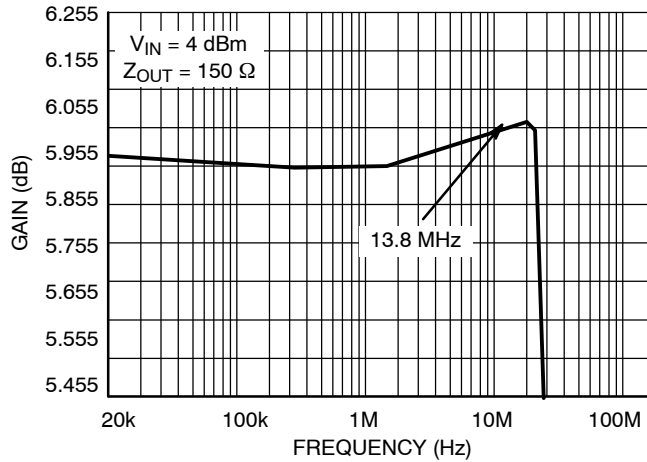

Figure 5. Flatness Bandwidth 0.1 dB

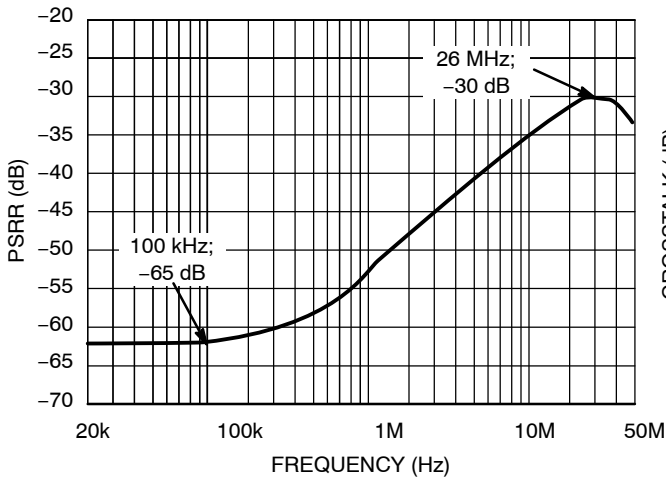

Figure 6. PSRR vs. Frequency (No Bypass Capacitor)

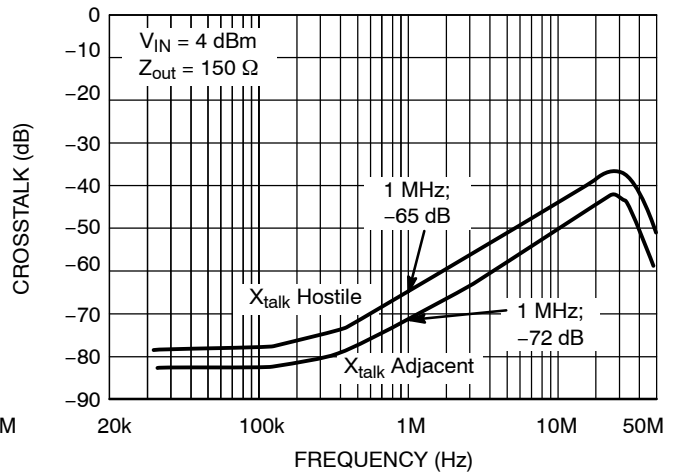

Figure 7. Crosstalk vs. Frequency, CH2/CH3 (100 μF AC-Coupled Input, DC-Coupled Output)

TYPICAL CHARACTERISTICS

$T_A = 25^\circ\text{C}$, $V_{CC} = 5\text{ V}$, $R_{\text{source}} = 37.5\ \Omega$, $0.1\ \mu\text{F}$ AC-Coupled Inputs, $220\ \mu\text{F}$ AC-Coupled Outputs with $150\ \Omega$

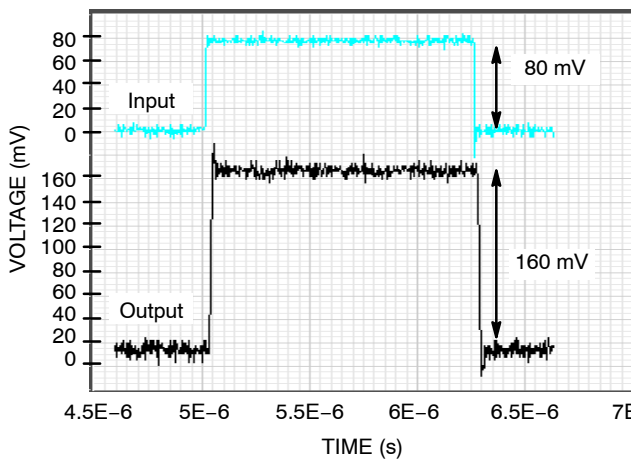

Figure 8. Small Signal Step Response
 $T_r = T_f = 1\text{ ns}$

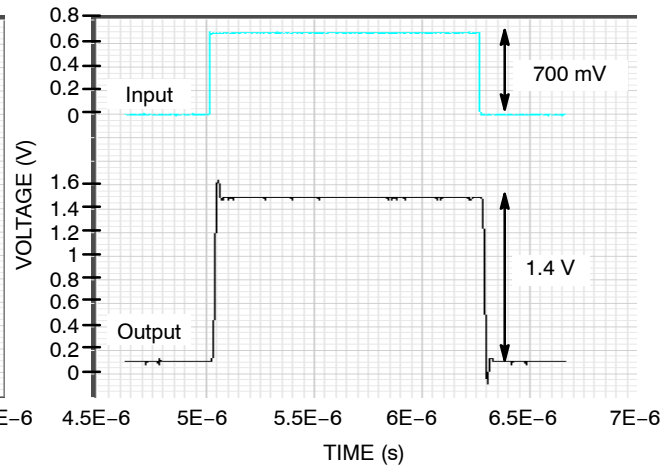

Figure 9. Large Signal Step Response
 $T_r = T_f = 1.0\text{ ns}$

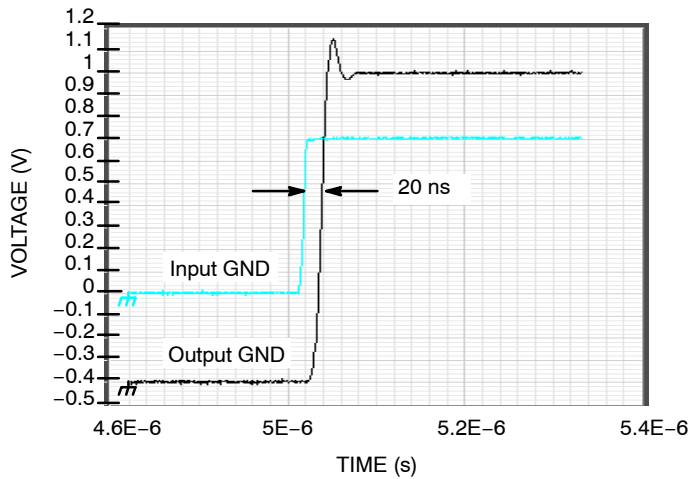

Figure 10. Propagation Delay vs. Time

APPLICATIONS INFORMATION

The NCS2563 triple video driver has been optimized for High Definition video applications covering the requirements of the standards 720p, 1080i and related (RGB). All the 3 channels feature the same specifications and similar behaviors guaranteed by a high channel-to-channel crosstalk isolation (down to 60 dB at 1 MHz). Each channel provides an internal voltage-to-voltage gain of 2 from its input to its output reducing by the way the number of external components usually needed in the case of some discrete approaches (using stand-alone op amps). An internal level shifter is employed shifting up the output voltage by adding an offset of about 280 mV. This avoids sync pulse clipping and allows

DC-coupled output to the 150 Ω video load. In addition, the NCS2563 integrates a 6th order Butterworth filter per channel with a 3 dB frequency bandwidth of 30 MHz. This allows rejecting out the aliases or unwanted over-sampling effects produced by the video DAC. It works the same way for DVD recorders using ADC, this anti-aliasing filter (reconstruction filter) will avoid picture quality issue and will help also to filter out parasitic signals caused by EMI interference.

A built-in diode-like clamp is used into the chip for each channel to support AC-coupled mode of operation. The clamp is active when the input signal goes below 0 V.

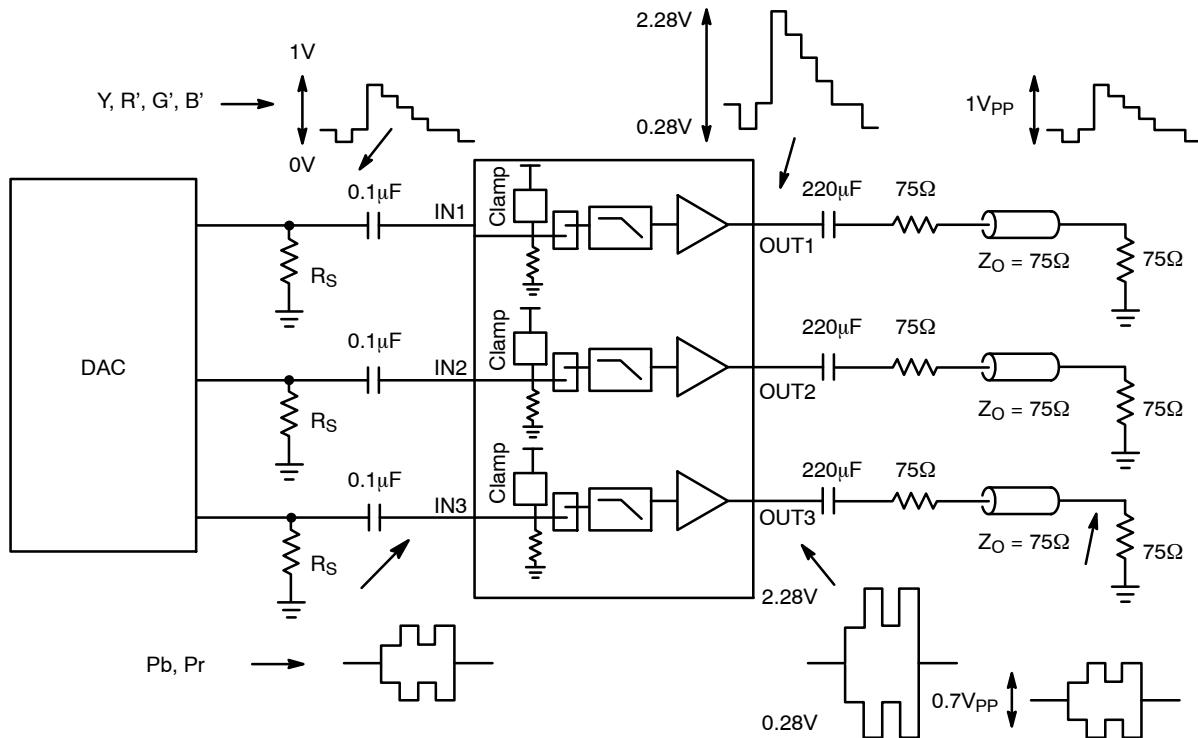

Figure 11. AC-Coupled Inputs and Outputs

Figure 11 shows an example for which the external video source coming from the DAC is AC-coupled at the input and output. But thanks to the built-in transparent clamp and level shifter the device can operate in different configuration modes depending essentially on the DAC output signal level High and Low and how it fits the input common mode voltage of the video driver. When the configuration is DC-Coupled at the Inputs and Outputs the 0.1 μF and 220 μF coupling capacitors are no longer used, the clamps are in that case inactive; this configuration has the big advantage of being relatively low cost with the use of less external components.

The input is AC-coupled if the input-signal amplitude goes over the range 0 V to 1.4 V or if the video source requires a coupling. In some circumstances it may be necessary to auto-bias signals by the addition of a pull-up and pull-down resistor or only pullup resistor (Typical 7.5 M Ω combined with the internal 800 k Ω pulldown) making the clamp inactive.

The output AC-coupling configuration has the advantage of eliminating DC ground loop with the drawback of making the device more sensitive to video line or field tilt issues in the case of a too low output coupling capacitor. In some cases it may be necessary to increase the nominal 220 μF capacitor value.

NCS2563

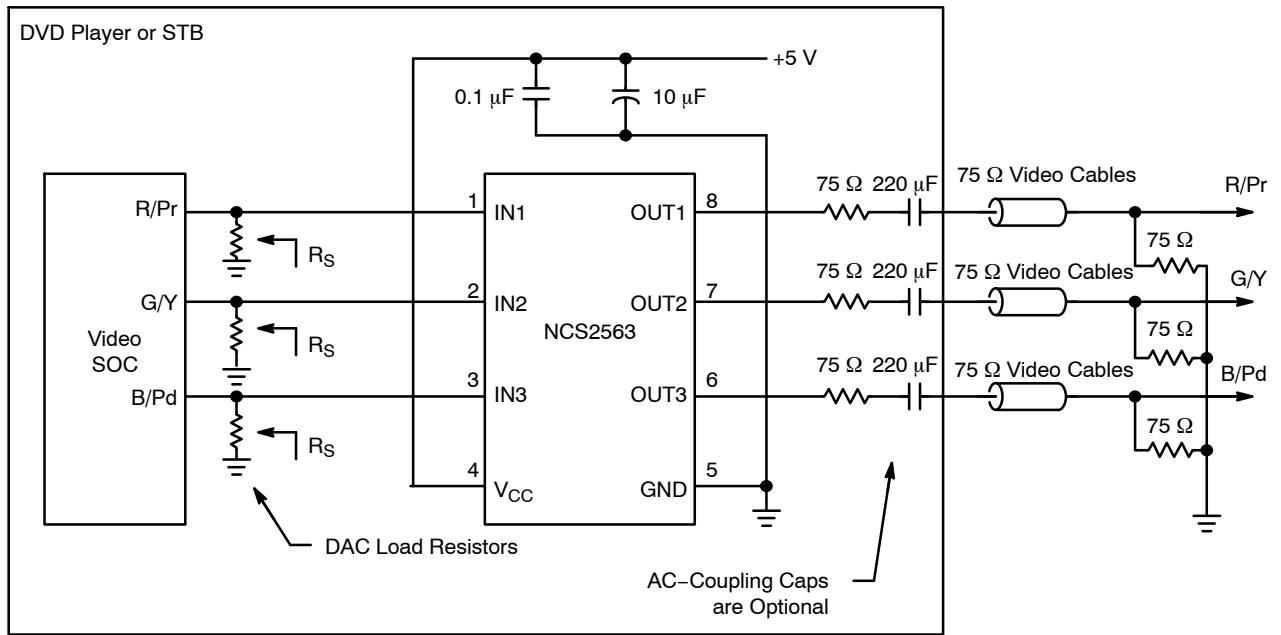
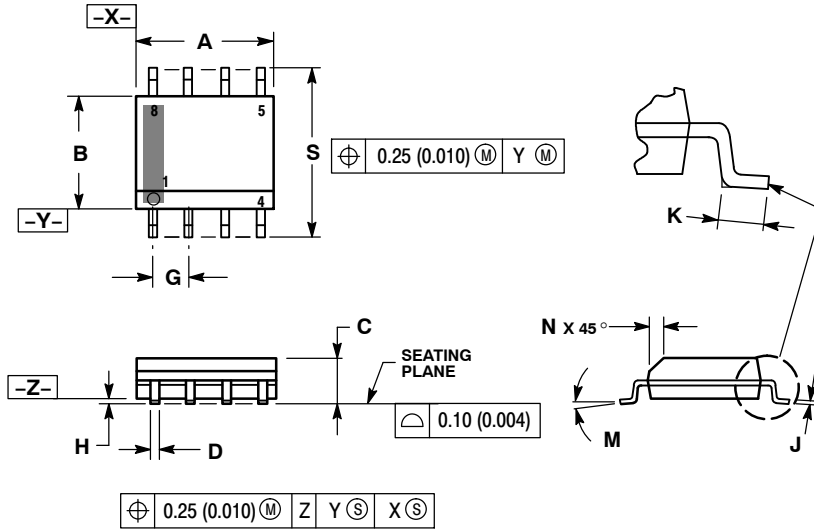

Figure 12. Typical Application Circuit

NCS2563

PACKAGE DIMENSIONS

SOIC-8 NB
CASE 751-07
ISSUE AJ



NOTES:

1. DIMENSIONING AND TOLERANCING PER ANSI Y14.5M, 1982.
2. CONTROLLING DIMENSION: MILLIMETER.
3. DIMENSION A AND B DO NOT INCLUDE MOLD PROTRUSION.
4. MAXIMUM MOLD PROTRUSION 0.15 (0.006) PER SIDE.
5. DIMENSION D DOES NOT INCLUDE DAMBAR PROTRUSION. ALLOWABLE DAMBAR PROTRUSION SHALL BE 0.127 (0.005) TOTAL IN EXCESS OF THE D DIMENSION AT MAXIMUM MATERIAL CONDITION.
6. 751-01 THRU 751-06 ARE OBSOLETE. NEW STANDARD IS 751-07.

DIM	MILLIMETERS		INCHES	
	MIN	MAX	MIN	MAX
A	4.80	5.00	0.189	0.197
B	3.80	4.00	0.150	0.157
C	1.35	1.75	0.053	0.069
D	0.33	0.51	0.013	0.020
G	1.27 BSC		0.050 BSC	
H	0.10	0.25	0.004	0.010
J	0.19	0.25	0.007	0.010
K	0.40	1.27	0.016	0.050
M	0°	8°	0°	8°
N	0.25	0.50	0.010	0.020
S	5.80	6.20	0.228	0.244

SOLDERING FOOTPRINT*

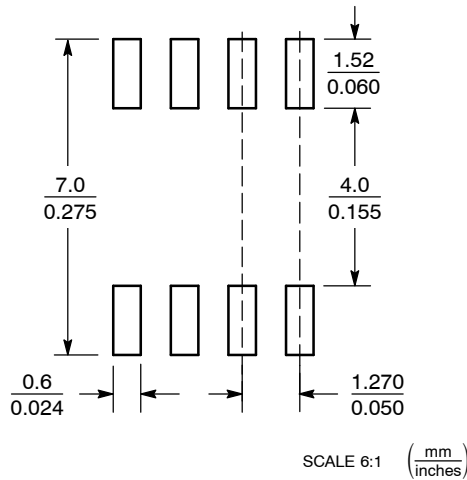

*For additional information on our Pb-Free strategy and soldering details, please download the ON Semiconductor Soldering and Mounting Techniques Reference Manual, SOLDERRM/D.

ON Semiconductor and are registered trademarks of Semiconductor Components Industries, LLC (SCILLC). SCILLC reserves the right to make changes without further notice to any products herein. SCILLC makes no warranty, representation or guarantee regarding the suitability of its products for any particular purpose, nor does SCILLC assume any liability arising out of the application or use of any product or circuit, and specifically disclaims any and all liability, including without limitation special, consequential or incidental damages. "Typical" parameters which may be provided in SCILLC data sheets and/or specifications can and do vary in different applications and actual performance may vary over time. All operating parameters, including "Typicals" must be validated for each customer application by customer's technical experts. SCILLC does not convey any license under its patent rights nor the rights of others. SCILLC products are not designed, intended, or authorized for use as components in systems intended for surgical implant into the body, or other applications intended to support or sustain life, or for any other application in which the failure of the SCILLC product could create a situation where personal injury or death may occur. Should Buyer purchase or use SCILLC products for any such unintended or unauthorized application, Buyer shall indemnify and hold SCILLC and its officers, employees, subsidiaries, affiliates, and distributors harmless against all claims, costs, damages, and expenses, and reasonable attorney fees arising out of, directly or indirectly, any claim of personal injury or death associated with such unintended or unauthorized use, even if such claim alleges that SCILLC was negligent regarding the design or manufacture of the part. SCILLC is an Equal Opportunity/Affirmative Action Employer. This literature is subject to all applicable copyright laws and is not for resale in any manner.

PUBLICATION ORDERING INFORMATION

LITERATURE FULFILLMENT:
Literature Distribution Center for ON Semiconductor
P.O. Box 5163, Denver, Colorado 80217 USA
Phone: 303-675-2175 or 800-344-3860 Toll Free USA/Canada
Fax: 303-675-2176 or 800-344-3867 Toll Free USA/Canada
Email: orderlit@onsemi.com

N. American Technical Support: 800-282-9855 Toll Free USA/Canada
Europe, Middle East and Africa Technical Support:
Phone: 421 33 790 2910
Japan Customer Focus Center
Phone: 81-3-5773-3850

ON Semiconductor Website: www.onsemi.com
Order Literature: <http://www.onsemi.com/orderlit>

For additional information, please contact your local Sales Representative

Компания «Океан Электроники» предлагает заключение долгосрочных отношений при поставках импортных электронных компонентов на взаимовыгодных условиях!

Наши преимущества:

- Поставка оригинальных импортных электронных компонентов напрямую с производств Америки, Европы и Азии, а так же с крупнейших складов мира;
- Широкая линейка поставок активных и пассивных импортных электронных компонентов (более 30 млн. наименований);
- Поставка сложных, дефицитных, либо снятых с производства позиций;
- Оперативные сроки поставки под заказ (от 5 рабочих дней);
- Экспресс доставка в любую точку России;
- Помощь Конструкторского Отдела и консультации квалифицированных инженеров;
- Техническая поддержка проекта, помощь в подборе аналогов, поставка прототипов;
- Поставка электронных компонентов под контролем ВП;
- Система менеджмента качества сертифицирована по Международному стандарту ISO 9001;
- При необходимости вся продукция военного и аэрокосмического назначения проходит испытания и сертификацию в лаборатории (по согласованию с заказчиком);
- Поставка специализированных компонентов военного и аэрокосмического уровня качества (Xilinx, Altera, Analog Devices, Intersil, Interpoint, Microsemi, Actel, Aeroflex, Peregrine, VPT, Syfer, Eurofarad, Texas Instruments, MS Kennedy, Miteq, Cobham, E2V, MA-COM, Hittite, Mini-Circuits, General Dynamics и др.);

Компания «Океан Электроники» является официальным дистрибьютором и эксклюзивным представителем в России одного из крупнейших производителей разъемов военного и аэрокосмического назначения «JONHON», а так же официальным дистрибьютором и эксклюзивным представителем в России производителя высокотехнологичных и надежных решений для передачи СВЧ сигналов «FORSTAR».



JONHON

«JONHON» (основан в 1970 г.)

Разъемы специального, военного и аэрокосмического назначения:

(Применяются в военной, авиационной, аэрокосмической, морской, железнодорожной, горно- и нефтедобывающей отраслях промышленности)

«FORSTAR» (основан в 1998 г.)

ВЧ соединители, коаксиальные кабели,
кабельные сборки и микроволновые компоненты:

(Применяются в телекоммуникациях гражданского и специального назначения, в средствах связи, РЛС, а так же военной, авиационной и аэрокосмической отраслях промышленности).



Телефон: 8 (812) 309-75-97 (многоканальный)

Факс: 8 (812) 320-03-32

Электронная почта: ocean@oceanchips.ru

Web: <http://oceanchips.ru/>

Адрес: 198099, г. Санкт-Петербург, ул. Калинина, д. 2, корп. 4, лит. А