



Kinetis K66 Sub-Family

180 MHz ARM® Cortex®-M4F Microcontroller.

The K66 sub-family members provide greater performance, memory options up to 2 MB total flash and 256 KB of SRAM, as well as higher peripheral integration with features such as Dual USB and a 10/100 Mbit/s Ethernet MAC. These devices maintain hardware and software compatibility with the existing Kinetis family. This product also offers:

- Integration of a High Speed USB Physical Transceiver
- Greater performance flexibility with a High Speed Run mode
- Smarter peripherals with operation in Stop modes

MK66FN2M0VMD18
MK66FX1M0VMD18
MK66FN2M0VLQ18
MK66FX1M0VLQ18

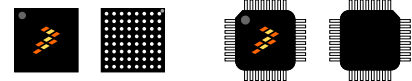

144 MAPBGA (MD) 144 LQFP (LQ)
13 mm x 13 mm Pitch 1 20 mm x 20 mm Pitch
mm 0.5 mm

Performance

- Up to 180 MHz ARM Cortex-M4 based core with DSP instructions and Single Precision Floating Point unit

System and Clocks

- Multiple low-power modes to provide power optimization based on application requirements
- Memory protection unit with multi-master protection
- 3 to 32 MHz main crystal oscillator
- 32 kHz low power crystal oscillator
- 48 MHz internal reference

Security

- Hardware random-number generator
- Supports DES, AES, SHA accelerator (CAU)
- Multiple levels of embedded flash security

Timers

- Four Periodic interrupt timers
- 16-bit low-power timer
- Two 16-bit low-power timer PWM modules
- Two 8-channel motor control/general purpose/PWM timers
- Two 2-ch quad decoder/general purpose timers
- Real-time clock

Human-machine interface

- Low-power hardware touch sensor interface (TSI)
- General-purpose input/output

Memories and memory expansion

- Up to 2 MB program flash memory on non-FlexMemory devices with 256 KB RAM
- Up to 1 MB program flash memory and 256 KB of FlexNVM on FlexMemory devices
- 4 KB FlexRAM on FlexMemory devices
- FlexBus external bus interface and SDRAM controller

Analog modules

- Two 16-bit SAR ADCs and two 12-bit DAC
- Four analog comparators (CMP) containing a 6-bit DAC and programmable reference input
- Voltage reference 1.2V

Communication interfaces

- Ethernet controller with MII and RMII interface to external PHY and hardware IEEE 1588 capability
- USB high-/full-/low-speed On-the-Go with on-chip high speed transceiver
- USB full-/low-speed OTG with on-chip transceiver
- Two CAN, three SPI and four I2C modules
- Low Power Universal Asynchronous Receiver/Transmitter 0 (LPUART0) and five standard UARTs
- Secure Digital Host Controller (SDHC)
- I2S module

Operating Characteristics

- Voltage/Flash write voltage range: 1.71 to 3.6 V
- Temperature range (ambient): -40 to 105°C



Ordering Information 1

Part Number	Memory		Maximum number of I/O's
	Flash	SRAM	
MK66FN2M0VMD18	2 MB	256 KB	100
MK66FX1M0VMD18	1.25 MB	256 KB	100
MK66FN2M0VLQ18	2 MB	256 KB	100
MK66FX1M0VLQ18	1.25 MB	256 KB	100

1. To confirm current availability of orderable part numbers, go to <http://www.nxp.com> and perform a part number search.

Related Resources

Type	Description	Resource
Selector Guide	The NXP Solution Advisor is a web-based tool that features interactive application wizards and a dynamic product selector.	Solution Advisor
Reference Manual	The Reference Manual contains a comprehensive description of the structure and function (operation) of a device.	K66P144M180SF5RMV2 ¹
Data Sheet	The Data Sheet includes electrical characteristics and signal connections.	This document.
Chip Errata	The chip mask set Errata provides additional or corrective information for a particular device mask set.	Kinetis_K_0N65N ¹
Package drawing	Package dimensions are provided in package drawings.	<ul style="list-style-type: none"> • MAPBGA 144-pin : 98ASA00222D¹ • LQFP 144-pin: 98ASS23177W¹

1. To find the associated resource, go to <http://www.nxp.com> and perform a search using this term.

Kinetic K66 Sub-Family

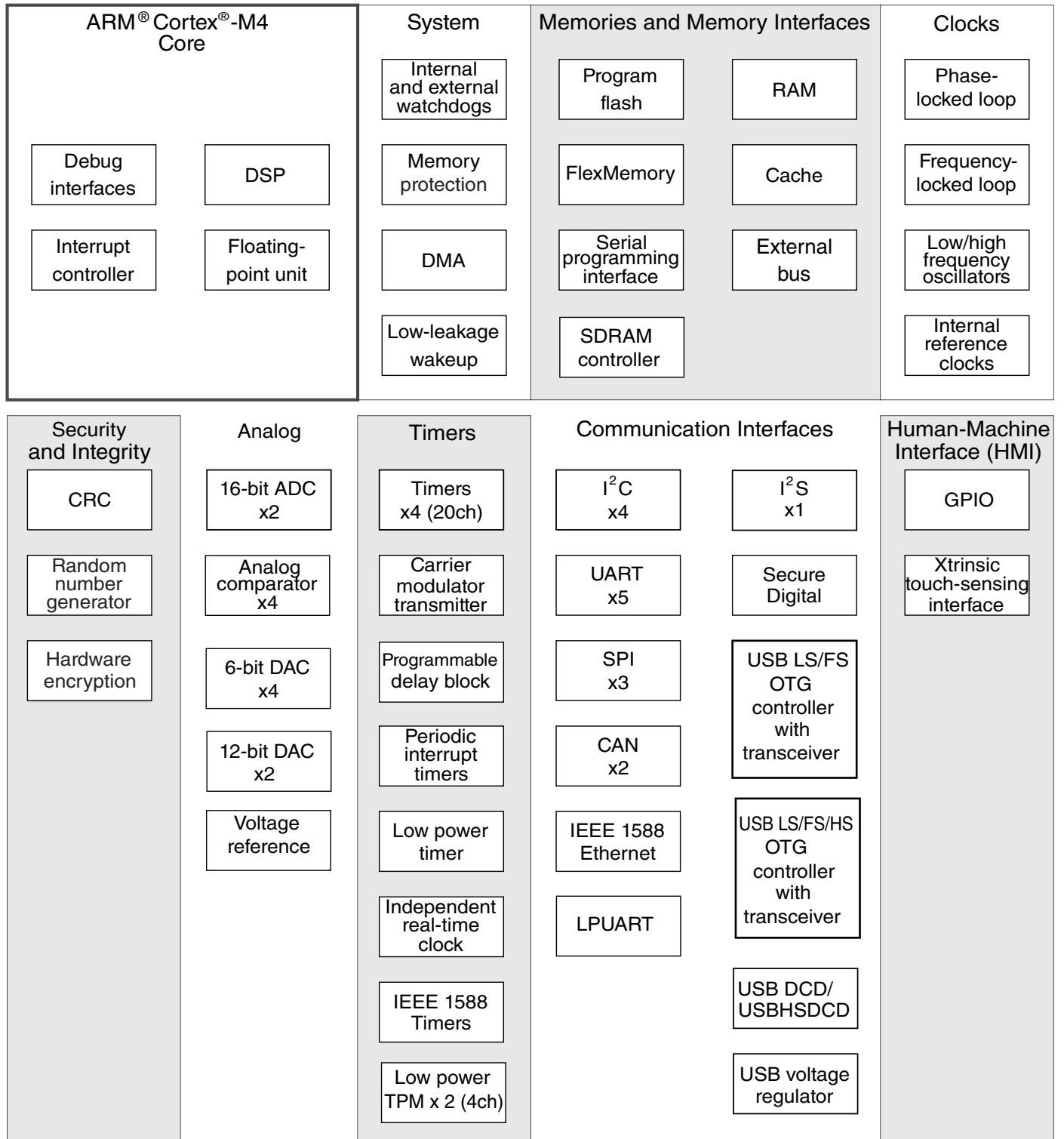

Figure 1. K66 Block Diagram

Table of Contents

1 Ratings.....	5	3.7 Timers.....	54
1.1 Thermal handling ratings.....	5	3.8 Communication interfaces.....	54
1.2 Moisture handling ratings.....	5	3.8.1 Ethernet switching specifications.....	55
1.3 ESD handling ratings.....	5	3.8.2 USB Voltage Regulator Electrical	
1.4 Voltage and current operating ratings.....	5	Specifications.....	58
2 General.....	6	3.8.3 USB Full Speed Transceiver and High Speed	
2.1 AC electrical characteristics.....	6	PHY specifications.....	59
2.2 Nonswitching electrical specifications.....	7	3.8.4 USB DCD electrical specifications.....	60
2.2.1 Voltage and current operating requirements.....	7	3.8.5 CAN switching specifications.....	60
2.2.2 LVD and POR operating requirements.....	8	3.8.6 DSPI switching specifications (limited voltage	
2.2.3 Voltage and current operating behaviors.....	9	range).....	60
2.2.4 Power mode transition operating behaviors.....	10	3.8.7 DSPI switching specifications (full voltage	
2.2.5 Power consumption operating behaviors.....	12	range).....	62
2.2.6 EMC radiated emissions operating behaviors...	16	3.8.8 Inter-Integrated Circuit Interface (I2C) timing...	64
2.2.7 Designing with radiated emissions in mind.....	17	3.8.9 UART switching specifications.....	65
2.2.8 Capacitance attributes.....	17	3.8.10 Low Power UART switching specifications.....	65
2.3 Switching specifications.....	17	3.8.11 SDHC specifications.....	66
2.3.1 Device clock specifications.....	17	3.8.12 I2S switching specifications.....	67
2.3.2 General switching specifications.....	18	3.9 Human-machine interfaces (HMI).....	73
2.4 Thermal specifications.....	19	3.9.1 TSI electrical specifications.....	73
2.4.1 Thermal operating requirements.....	19	4 Dimensions.....	73
2.4.2 Thermal attributes.....	19	4.1 Obtaining package dimensions.....	73
3 Peripheral operating requirements and behaviors.....	21	5 Pinout.....	74
3.1 Core modules.....	21	5.1 K66 Signal Multiplexing and Pin Assignments.....	74
3.1.1 Debug trace timing specifications.....	21	5.2 Recommended connection for unused analog and	
3.1.2 JTAG electricals.....	21	digital pins.....	81
3.2 System modules.....	24	5.3 K66 Pinouts.....	82
3.3 Clock modules.....	24	6 Ordering parts.....	84
3.3.1 MCG specifications.....	24	6.1 Determining valid orderable parts.....	84
3.3.2 IRC48M specifications.....	27	7 Part identification.....	85
3.3.3 Oscillator electrical specifications.....	28	7.1 Description.....	85
3.3.4 32 kHz oscillator electrical characteristics.....	31	7.2 Format.....	85
3.4 Memories and memory interfaces.....	31	7.3 Fields.....	85
3.4.1 Flash (FTFE) electrical specifications.....	31	7.4 Example.....	86
3.4.2 EzPort switching specifications.....	36	8 Terminology and guidelines.....	86
3.4.3 Flexbus switching specifications.....	37	8.1 Definitions.....	86
3.4.4 SDRAM controller specifications.....	40	8.2 Examples.....	87
3.5 Security and integrity modules.....	43	8.3 Typical-value conditions.....	87
3.6 Analog.....	43	8.4 Relationship between ratings and operating	
3.6.1 ADC electrical specifications.....	43	requirements.....	88
3.6.2 CMP and 6-bit DAC electrical specifications.....	48	8.5 Guidelines for ratings and operating requirements.....	88
3.6.3 12-bit DAC electrical characteristics.....	50	9 Revision History.....	89
3.6.4 Voltage reference electrical specifications.....	53		

1 Ratings

1.1 Thermal handling ratings

Symbol	Description	Min.	Max.	Unit	Notes
T _{STG}	Storage temperature	-55	150	°C	1
T _{SDR}	Solder temperature, lead-free	—	260	°C	2

1. Determined according to JEDEC Standard JESD22-A103, *High Temperature Storage Life*.
2. Determined according to IPC/JEDEC Standard J-STD-020, *Moisture/Reflow Sensitivity Classification for Nonhermetic Solid State Surface Mount Devices*.

1.2 Moisture handling ratings

Symbol	Description	Min.	Max.	Unit	Notes
MSL	Moisture sensitivity level	—	3	—	1

1. Determined according to IPC/JEDEC Standard J-STD-020, *Moisture/Reflow Sensitivity Classification for Nonhermetic Solid State Surface Mount Devices*.

1.3 ESD handling ratings

Symbol	Description	Min.	Max.	Unit	Notes
V _{HBM}	Electrostatic discharge voltage, human body model	-2000	+2000	V	1
V _{CDM}	Electrostatic discharge voltage, charged-device model	-500	+500	V	2
I _{LAT}	Latch-up current at ambient temperature of 105°C	-100	+100	mA	3

1. Determined according to JEDEC Standard JESD22-A114, *Electrostatic Discharge (ESD) Sensitivity Testing Human Body Model (HBM)*.
2. Determined according to JEDEC Standard JESD22-C101, *Field-Induced Charged-Device Model Test Method for Electrostatic-Discharge-Withstand Thresholds of Microelectronic Components*.
3. Determined according to JEDEC Standard JESD78, *IC Latch-Up Test*.

1.4 Voltage and current operating ratings

General

Symbol	Description	Min.	Max.	Unit
V_{DD}	Digital supply voltage	-0.3	3.8	V
I_{DD}	Digital supply current	—	300	mA
V_{DIO}	Digital ¹ input voltage, including RESET_b	-0.3	$V_{DD} + 0.3$	V
V_{AIO}	Analog ¹ input voltage, including EXTAL32 and XTAL32	-0.3	$V_{DD} + 0.3$	V
I_D	Maximum current single pin limit (digital output pins)	-25	25	mA
V_{DDA}	Analog supply voltage	$V_{DD} - 0.3$	$V_{DD} + 0.3$	V
V_{USB0_DP}	USB0_DP input voltage	-0.3	3.63	V
V_{USB1_DP}	USB1_DP input voltage	-0.3	3.63	V
V_{USB0_DM}	USB0_DM input voltage	-0.3	3.63	V
V_{USB1_DM}	USB1_DM input voltage	-0.3	3.63	V
V_{USB1_VBUS}	USB1_VBUS detect voltage	-0.3	6.0	V
VREG_IN0, VREG_IN1	USB regulator input	-0.3	6.0	V
V_{BAT}	RTC battery supply voltage	-0.3	3.8	V

1. Digital pins have a general purpose I/O port assigned (e.g. PTA0). Analog pins do not have an associated general purpose I/O port.

2 General

2.1 AC electrical characteristics

Unless otherwise specified, propagation delays are measured from the 50% to the 50% point, and rise and fall times are measured at the 20% and 80% points, as shown in the following figure.

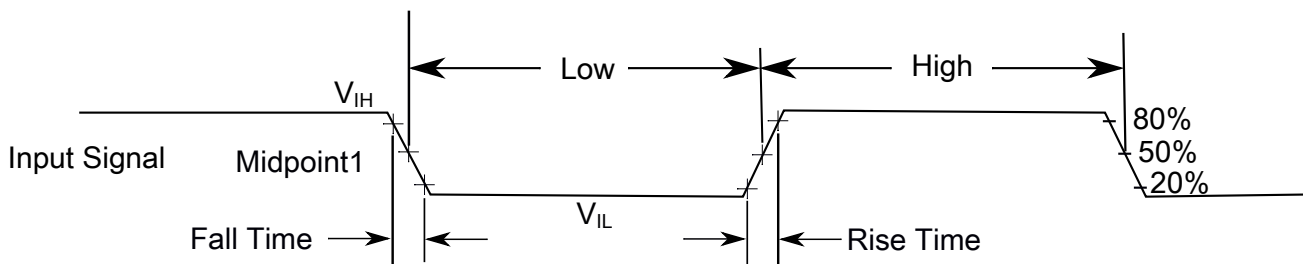

The midpoint is $V_{IL} + (V_{IH} - V_{IL}) / 2$

Figure 2. Input signal measurement reference

All digital I/O switching characteristics assume:

1. output pins

- have $C_L=30\text{pF}$ loads,
 - are slew rate disabled, and
 - are normal drive strength
2. input pins
- have their passive filter disabled ($\text{PORTx_PCRn[PFE]}=0$)

2.2 Nonswitching electrical specifications

2.2.1 Voltage and current operating requirements

Table 1. Voltage and current operating requirements

Symbol	Description	Min.	Max.	Unit	Notes
V_{DD}	Supply voltage	1.71	3.6	V	
V_{DDA}	Analog supply voltage	1.71	3.6	V	
$V_{DD} - V_{DDA}$	V_{DD} -to- V_{DDA} differential voltage	-0.1	0.1	V	
$V_{SS} - V_{SSA}$	V_{SS} -to- V_{SSA} differential voltage	-0.1	0.1	V	
V_{BAT}	RTC battery supply voltage	1.71	3.6	V	
V_{IH}	Input high voltage <ul style="list-style-type: none"> • $2.7\text{ V} \leq V_{DD} \leq 3.6\text{ V}$ • $1.71\text{ V} \leq V_{DD} \leq 2.7\text{ V}$ 	$0.7 \times V_{DD}$ $0.75 \times V_{DD}$	— —	V V	
V_{IL}	Input low voltage <ul style="list-style-type: none"> • $2.7\text{ V} \leq V_{DD} \leq 3.6\text{ V}$ • $1.71\text{ V} \leq V_{DD} \leq 2.7\text{ V}$ 	— —	$0.35 \times V_{DD}$ $0.3 \times V_{DD}$	V V	
V_{HYS}	Input hysteresis	$0.06 \times V_{DD}$	—	V	
I_{ICDIO}	Digital ¹ input pin negative DC injection current (except RTC_WAKEUP pins) — single pin <ul style="list-style-type: none"> • $V_{IN} < V_{SS}-0.3\text{V}$ 	-5	—	mA	2
I_{ICAIO}	Analog ¹ input pin DC injection current — single pin <ul style="list-style-type: none"> • $V_{IN} < V_{SS}-0.3\text{V}$ (Negative current injection) 	-5	—	mA	2
I_{ICcont}	Contiguous pin DC injection current —regional limit, includes sum of negative injection currents of 16 contiguous pin <ul style="list-style-type: none"> • Negative current injection 	-25	—	mA	
V_{ODPU}	Pseudo Open drain pullup voltage level	V_{DD}	V_{DD}	V	3
V_{RAM}	V_{DD} voltage required to retain RAM	1.2	—	V	
V_{RFVBAT}	V_{BAT} voltage required to retain the VBAT register file	V_{POR_VBAT}	—	V	

General

1. Digital pins have a general purpose I/O port assigned (e.g. PTA0). Analog pins do not have an associated general purpose I/O port.
2. All digital and analog I/O pins are internally clamped to V_{SS} through an ESD protection diode. There is no diode connection to V_{DD} . If V_{IN} is less than $V_{SS}-0.3V$, a current limiting resistor is required. The minimum negative DC injection current limiting resistor value is calculated as $R=(-0.3-V_{IN})/|I_{ICDIO}|$ or $R=(-0.3-V_{IN})/|I_{ICAI0}|$. The actual resistor should be an order of magnitude higher to tolerate transient voltages.
3. Open drain outputs must be pulled to VDD.

2.2.2 LVD and POR operating requirements

Table 2. V_{DD} supply LVD and POR operating requirements

Symbol	Description	Min.	Typ.	Max.	Unit	Notes
V_{POR}	Falling VDD POR detect voltage	0.8	1.1	1.5	V	
V_{LVDH}	Falling low-voltage detect threshold — high range (LVDV=01)	2.48	2.56	2.64	V	
V_{LVW1H}	Low-voltage warning thresholds — high range <ul style="list-style-type: none"> • Level 1 falling (LVWV=00) • Level 2 falling (LVWV=01) • Level 3 falling (LVWV=10) • Level 4 falling (LVWV=11) 	2.62	2.70	2.78	V	1
V_{LVW2H}		2.72	2.80	2.88	V	
V_{LVW3H}		2.82	2.90	2.98	V	
V_{LVW4H}		2.92	3.00	3.08	V	
V_{HYSH}	Low-voltage inhibit reset/recover hysteresis — high range	—	80	—	mV	
V_{LVDL}	Falling low-voltage detect threshold — low range (LVDV=00)	1.54	1.60	1.66	V	
V_{LVW1L}	Low-voltage warning thresholds — low range <ul style="list-style-type: none"> • Level 1 falling (LVWV=00) • Level 2 falling (LVWV=01) • Level 3 falling (LVWV=10) • Level 4 falling (LVWV=11) 	1.74	1.80	1.86	V	1
V_{LVW2L}		1.84	1.90	1.96	V	
V_{LVW3L}		1.94	2.00	2.06	V	
V_{LVW4L}		2.04	2.10	2.16	V	
V_{HYSL}	Low-voltage inhibit reset/recover hysteresis — low range	—	60	—	mV	
V_{BG}	Bandgap voltage reference	0.97	1.00	1.03	V	
t_{LPO}	Internal low power oscillator period — factory trimmed	900	1000	1100	μs	

1. Rising threshold is the sum of falling threshold and hysteresis voltage

Table 3. VBAT power operating requirements

Symbol	Description	Min.	Typ.	Max.	Unit	Notes
V_{POR_VBAT}	Falling VBAT supply POR detect voltage	0.8	1.1	1.5	V	

2.2.3 Voltage and current operating behaviors

Table 4. Voltage and current operating behaviors

Symbol	Description	Min.	Typ.	Max.	Unit	Notes
V_{OH}	Output high voltage — normal drive pad <ul style="list-style-type: none"> • $2.7\text{ V} \leq V_{DD} \leq 3.6\text{ V}$, $I_{OH} = -10\text{mA}$ • $1.71\text{ V} \leq V_{DD} \leq 2.7\text{ V}$, $I_{OH} = -5\text{mA}$ 	$V_{DD} - 0.5$	—	—	V	
		$V_{DD} - 0.5$	—	—	V	
	Output high voltage — High drive pad <ul style="list-style-type: none"> • $2.7\text{ V} \leq V_{DD} \leq 3.6\text{ V}$, $I_{OH} = -20\text{mA}$ • $1.71\text{ V} \leq V_{DD} \leq 2.7\text{ V}$, $I_{OH} = -10\text{mA}$ 	$V_{DD} - 0.5$	—	—	V	
		$V_{DD} - 0.5$	—	—	V	
I_{OHT}	Output high current total for all ports	—	—	100	mA	
$V_{OH_RTC_WAKEUP}$	Output high voltage— normal drive pad <ul style="list-style-type: none"> • $2.7\text{ V} \leq V_{BAT} \leq 3.6\text{ V}$, $I_{OH} = -5\text{ mA}$ • $1.71\text{ V} \leq V_{BAT} \leq 2.7\text{ V}$, $I_{OH} = -2.5\text{ mA}$ 	$V_{BAT} - 0.5$	—		V	
		$V_{BAT} - 0.5$	—		V	
$I_{OH_RTC_WAKEUP}$	Output high current total for RTC_WAKEUP pins	—	—	100	mA	
V_{OL}	Output low voltage — normal drive pad <ul style="list-style-type: none"> • $2.7\text{ V} \leq V_{DD} \leq 3.6\text{ V}$, $I_{OL} = 10\text{ mA}$ • $1.71\text{ V} \leq V_{DD} \leq 2.7\text{ V}$, $I_{OL} = 5\text{ mA}$ 	—	—	0.5	V	
		—	—	0.5	V	
	Output low voltage — high drive pad <ul style="list-style-type: none"> • $2.7\text{ V} \leq V_{DD} \leq 3.6\text{ V}$, $I_{OL} = 20\text{ mA}$ • $1.71\text{ V} \leq V_{DD} \leq 2.7\text{ V}$, $I_{OL} = 10\text{ mA}$ 	—	—	0.5	V	
		—	—	0.5	V	
I_{OLT}	Output low current total for all ports	—	—	100	mA	
$V_{OL_RTC_WAKEUP}$	Output low voltage— normal drive pad <ul style="list-style-type: none"> • $2.7\text{ V} \leq V_{BAT} \leq 3.6\text{ V}$, $I_{OL} = 5\text{ mA}$ • $1.71\text{ V} \leq V_{BAT} \leq 2.7\text{ V}$, $I_{OL} = 2.5\text{mA}$ 	—		0.5	V	
		—		0.5	V	
$I_{OL_RTC_WAKEUP}$	Output low current total for RTC_WAKEUP pins	—	—	100	mA	
I_{IN}	Input leakage current, analog and digital pins <ul style="list-style-type: none"> • $V_{SS} \leq V_{IN} \leq V_{DD}$ 	—	0.002	0.5	μA	1
$I_{OZ_RTC_WAKEUP}$	Hi-Z (off-state) leakage current (per RTC_WAKEUP pin)	—	—	0.25	μA	
R_{PU}	Internal pullup resistors	20	—	50	k Ω	2
R_{PD}	Internal pulldown resistors	20	—	50	k Ω	3

1. Measured at $V_{DD}=3.6\text{V}$

2. Measured at V_{DD} supply voltage = V_{DD} min and $V_{input} = V_{SS}$

General

3. Measured at V_{DD} supply voltage = V_{DD} min and $V_{input} = V_{DD}$

2.2.4 Power mode transition operating behaviors

All specifications except t_{POR} , and $VLLSx \rightarrow RUN$ recovery times in the following table assume this clock configuration:

- CPU and system clocks = 100MHz
- Bus clock = 50MHz
- FlexBus clock = 50 MHz
- Flash clock = 25 MHz
- MCG mode=FEI

Table 5. Power mode transition operating behaviors

Symbol	Description	Min.	Max.	Unit	Notes
t_{POR}	After a POR event, amount of time from the point V_{DD} reaches 1.71 V to execution of the first instruction across the operating temperature range of the chip.	—	300	μs	
	• $VLLS0 \rightarrow RUN$	—	172	μs	
	• $VLLS1 \rightarrow RUN$	—	172	μs	
	• $VLLS2 \rightarrow RUN$	—	94	μs	
	• $VLLS3 \rightarrow RUN$	—	94	μs	
	• $LLS2 \rightarrow RUN$	—	5.8	μs	
	• $LLS3 \rightarrow RUN$	—	5.8	μs	
	• $VLPS \rightarrow RUN$	—	5.4	μs	
	• $STOP \rightarrow RUN$	—	5.4	μs	

Table 6. Low power mode peripheral adders — typical value

Symbol	Description	Temperature ($^{\circ}C$)						Unit
		-40	25	50	70	85	105	
$I_{REFSTEN4MHz}$	4 MHz internal reference clock (IRC) adder. Measured by entering STOP or VLPS mode with 4 MHz IRC enabled.	56	56	56	56	56	56	μA

Table continues on the next page...

Table 6. Low power mode peripheral adders — typical value (continued)

Symbol	Description	Temperature (°C)						Unit
		-40	25	50	70	85	105	
I _{IREFSTEN32KH_z}	32 kHz internal reference clock (IRC) adder. Measured by entering STOP mode with the 32 kHz IRC enabled.	52	52	52	52	52	52	μA
I _{IREFSTEN4MH_z}	External 4 MHz crystal clock adder. Measured by entering STOP or VLPS mode with the crystal enabled.	206	228	237	245	251	258	μA
I _{IREFSTEN32K_{Hz}}	External 32 kHz crystal clock adder by means of the OSC0_CR[EREFSTEN and EREFSTEN] bits. Measured by entering all modes with the crystal enabled.							nA
	VLLS1	440	490	540	560	570	580	
	VLLS3	440	490	540	560	570	580	
	LLS2	490	490	540	560	570	680	
	LLS3	490	490	540	560	570	680	
	VLPS	510	560	560	560	610	680	
	STOP	510	560	560	560	610	680	
I _{48MIRC}	48MHz IRC	511	520	545	556	563	576	μA
I _{CMP}	CMP peripheral adder measured by placing the device in VLLS1 mode with CMP enabled using the 6-bit DAC and a single external input for compare. Includes 6-bit DAC power consumption.	22	22	22	22	22	22	μA
I _{RTC}	RTC peripheral adder measured by placing the device in VLLS1 mode with external 32 kHz crystal enabled by means of the RTC_CR[OSCE] bit and the RTC ALARM set for 1 minute. Includes ERCLK32K (32 kHz external crystal) power consumption.	432	357	388	475	532	810	nA
I _{UART}	UART peripheral adder measured by placing the device in STOP or VLPS mode with selected clock source waiting for RX data at 115200 baud rate. Includes selected clock source power consumption.							μA
	MCGIRCLK (4 MHz internal reference clock)	66	66	66	66	66	66	
	OSCERCLK (4 MHz external crystal)	214	234	246	254	260	268	
I _{BG}	Bandgap adder when BGEN bit is set and device is placed in VLPx, LLS, or VLLSx mode.	45	45	45	45	45	45	μA
I _{ADC}	ADC peripheral adder combining the measured values at V _{DD} and V _{DDA} by placing the device in STOP or VLPS mode. ADC is configured for low power mode using the internal clock and continuous conversions.	366	366	366	366	366	366	μA

2.2.5 Power consumption operating behaviors

NOTE

The maximum values represent characterized results equivalent to the mean plus three times the standard deviation (mean + 3 sigma)

Table 7. Power consumption operating behaviors

Symbol	Description	Min.	Typ.	Max.	Unit	Notes
I _{DDA}	Analog supply current	—	—	See note	mA	1
I _{DD_RUN}	Run mode current — all peripheral clocks disabled, code executing from flash <ul style="list-style-type: none"> • @ 1.8V • @ 3.0V 	—	32.3	71.03	mA	2
I _{DD_RUN}	Run mode current — all peripheral clocks enabled, code executing from flash <ul style="list-style-type: none"> • @ 1.8V • @ 3.0V <ul style="list-style-type: none"> • @ 25°C • @ 105°C 	—	50.5	89.58	mA	3, 4
I _{DD_RUNC} O	Run mode current in compute operation - 120 MHz core / 24 MHz flash / bus clock disabled, code of while(1) loop executing from flash <ul style="list-style-type: none"> • at 3.0 V 	—	28.5	67.74	mA	5
I _{DD_HSRUN}	Run mode current — all peripheral clocks disabled, code executing from flash <ul style="list-style-type: none"> • @ 1.8V • @ 3.0V 	—	47.2	91.25	mA	6
I _{DD_HSRUN}	Run mode current — all peripheral clocks enabled, code executing from flash <ul style="list-style-type: none"> • @ 1.8V • @ 3.0V <ul style="list-style-type: none"> • @ 25°C • @ 105°C 	—	71.4	103.58	mA	7, 4
I _{DD_HSRUN} CO	HSRun mode current in compute operation – 168 MHz core/ 28 MHz flash / bus clock disabled, code of while(1) loop executing from flash at 3.0V	—	42.9	91.97	mA	5
I _{DD_WAIT}	Wait mode high frequency current at 3.0 V — all peripheral clocks disabled	—	16.9	45.2	mA	8

Table continues on the next page...

Table 7. Power consumption operating behaviors (continued)

Symbol	Description	Min.	Typ.	Max.	Unit	Notes
I _{DD_WAIT}	Wait mode reduced frequency current at 3.0 V — all peripheral clocks enabled	—	35	62.81	mA	8
I _{DD_VLPR}	Very-low-power run mode current at 3.0 V — all peripheral clocks disabled	—	1.1	9.56	mA	9
I _{DD_VLPR}	Very-low-power run mode current at 3.0 V — all peripheral clocks enabled	—	2	9.88	mA	10
I _{DD_VLPRC} O	Very-low-power run mode current in compute operation - 4 MHz core / 1 MHz flash / bus clock disabled, LPTMR running with 4 MHz internal reference clock <ul style="list-style-type: none"> at 3.0 V 	—	986	9.47	μA	11
I _{DD_VLPW}	Very-low-power wait mode current at 3.0 V — all peripheral clocks disabled	—	0.690	9.25	mA	12
I _{DD_VLPW}	Very-low-power wait mode current at 3.0 V — all peripheral clocks enabled	—	1.5	10.00	mA	
I _{DD_STOP}	Stop mode current at 3.0 V <ul style="list-style-type: none"> @ -40 to 25°C @ 70°C @ 105°C 	—	0.791	2.39	mA	
		—	3.8	6.91	mA	
		—	13.2	18.91	mA	
I _{DD_VLPS}	Very-low-power stop mode current at 3.0 V <ul style="list-style-type: none"> @ -40 to 25°C @ 70°C @ 105°C 	—	202	353.77	μA	
		—	1400	2464.54	μA	
		—	5100	8949.06	μA	
I _{DD_LLS3}	Low leakage stop mode current at 3.0 V <ul style="list-style-type: none"> @ -40 to 25°C @ 70°C @ 105°C 	—	9.0	16.5	μA	
		—	76.3	88.63	μA	
		—	402	656.08	μA	
I _{DD_LLS2}	Low leakage stop mode current at 3.0 V <ul style="list-style-type: none"> @ -40 to 25°C @ 70°C @ 105°C 	—	5.7	9.7	μA	
		—	41.3	55.80	μA	
		—	229	276.81	μA	
I _{DD_VLLS3}	Very low-leakage stop mode 3 current at 3.0 V <ul style="list-style-type: none"> @ -40 to 25°C @ 70°C @ 105°C 	—	5.5	7.31	μA	
		—	46.3	58.33	μA	
		—	249	380.77	μA	
I _{DD_VLLS2}	Very low-leakage stop mode 2 current at 3.0 V <ul style="list-style-type: none"> @ -40 to 25°C @ 70°C @ 105°C 	—	2.7	3.24	μA	
		—	13.1	18.72	μA	
		—	76.6	84.77	μA	

Table continues on the next page...

Table 7. Power consumption operating behaviors (continued)

Symbol	Description	Min.	Typ.	Max.	Unit	Notes
I _{DD_VLLS1}	Very low-leakage stop mode 1 current at 3.0 V <ul style="list-style-type: none"> • @ -40 to 25°C • @ 70°C • @ 105°C 	—	0.847	1.48	μA	
		—	6.5	11.31	μA	
		—	46.7	81.78	μA	
I _{DD_VLLS0}	Very low-leakage stop mode 0 current at 3.0 V with POR detect circuit enabled <ul style="list-style-type: none"> • @ -40 to 25°C • @ 70°C • @ 105°C 	—	0.551	.65	μA	
		—	6.3	7.12	μA	
		—	49.6	53.68	μA	
I _{DD_VLLS0}	Very low-leakage stop mode 0 current at 3.0 V with POR detect circuit disabled <ul style="list-style-type: none"> • @ -40 to 25°C • @ 70°C • @ 105°C 	—	0.254	0.445	μA	
		—	6.3	10.99	μA	
		—	48.7	85.27	μA	
I _{DD_VBAT}	Average current with RTC and 32kHz disabled at 3.0 V <ul style="list-style-type: none"> • @ -40 to 25°C • @ 70°C • @ 105°C 	—	0.19	0.22	μA	
		—	0.49	0.64	μA	
		—	2.2	3.2	μA	
I _{DD_VBAT}	Average current when CPU is not accessing RTC registers <ul style="list-style-type: none"> • @ 1.8V <ul style="list-style-type: none"> • @ -40 to 25°C • @ 70°C • @ 105°C • @ 3.0V <ul style="list-style-type: none"> • @ -40 to 25°C • @ 70°C • @ 105°C 	—	0.68	0.8	μA	13
		—	1.2	1.56	μA	
		—	3.6	5.3	μA	
		—	0.81	0.96	μA	
		—	1.45	1.89	μA	
		—	4.3	6.33	μA	
		—			μA	

1. The analog supply current is the sum of the active or disabled current for each of the analog modules on the device. See each module's specification for its supply current.
2. 120 MHz core and system clock, 60 MHz bus and FlexBus clock, and 24 MHz flash clock. MCG configured for PEE mode. All peripheral clocks disabled.
3. 120 MHz core and system clock, 60 MHz bus and FlexBus clock, and 24 MHz flash clock. MCG configured for PEE mode. All peripheral clocks enabled.
4. Max values are measured with CPU executing DSP instructions.
5. MCG configured for PEE mode.
6. 168 MHz core and system clock, 56 MHz bus and FlexBus clock, and 28 MHz flash clock. MCG configured for PEE mode. All peripheral clocks disabled.
7. 168 MHz core and system clock, 56 MHz bus and FlexBus clock, and 28 MHz flash clock. MCG configured for PEE mode. All peripheral clocks enabled.

8. 120 MHz core and system clock, 60MHz bus clock, and FlexBus. MCG configured for PEE mode.
9. 4 MHz core, system, FlexBus, and bus clock and 1 MHz flash clock. MCG configured for BLPE mode. All peripheral clocks disabled. Code executing from flash.
10. 4 MHz core, system, FlexBus, and bus clock and 1 MHz flash clock. MCG configured for BLPE mode. All peripheral clocks enabled but peripherals are not in active operation. Code executing from flash.
11. MCG configured for BLPI mode. CoreMark benchmark compiled using IAR 6.40 with optimization level high, optimized for balanced.
12. 4 MHz core, system, FlexBus, and bus clock and 1 MHz flash clock. MCG configured for BLPE mode. All peripheral clocks disabled.
13. Includes 32kHz oscillator current and RTC operation.

2.2.5.1 Diagram: Typical IDD_RUN operating behavior

The following data was measured under these conditions:

- USB regulator disabled
- No GPIOs toggled
- Code execution from flash with cache enabled
- For the ALLOFF curve, all peripheral clocks are disabled except FTFE

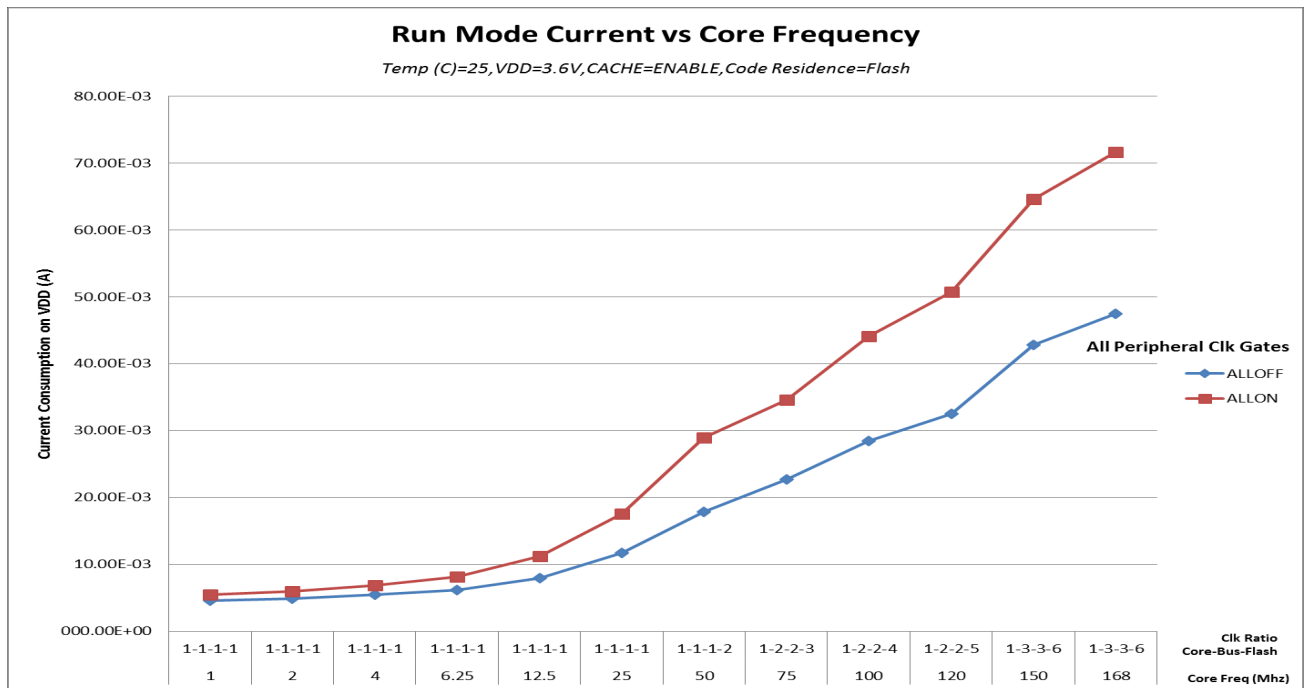

Figure 3. Run mode supply current vs. core frequency

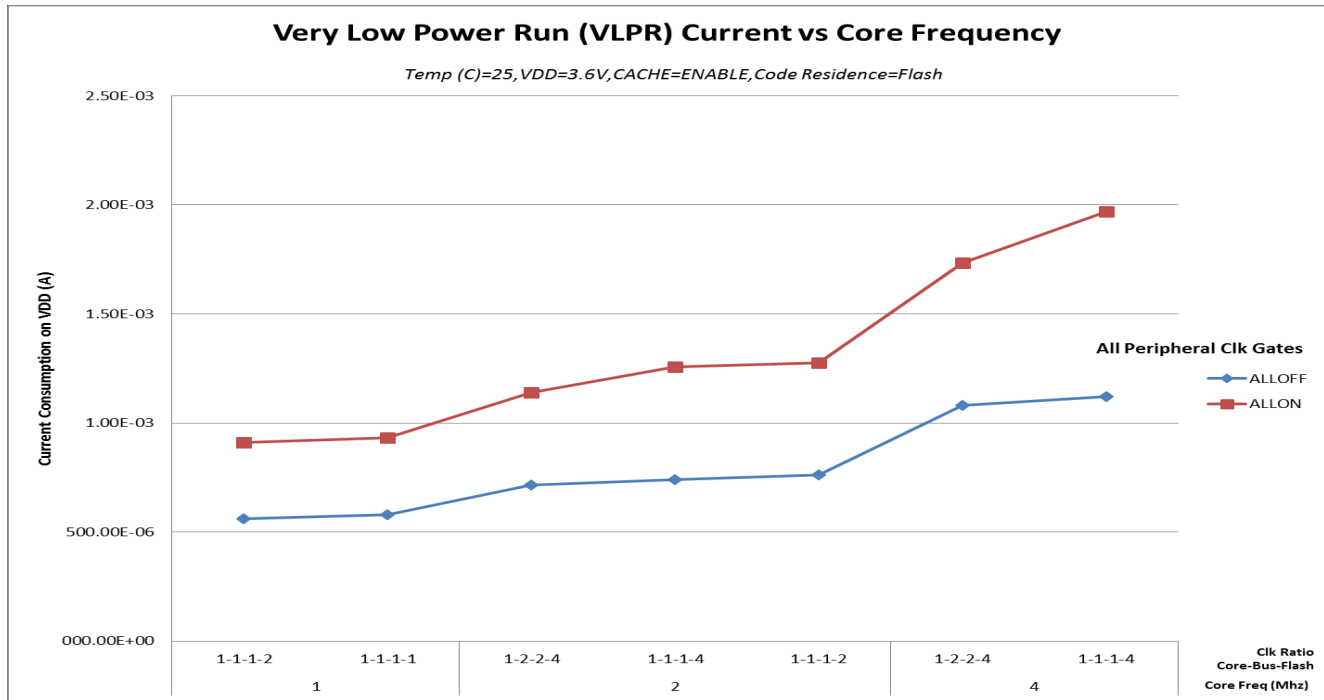

Figure 4. VLPR mode supply current vs. core frequency

2.2.6 EMC radiated emissions operating behaviors

Table 8. EMC radiated emissions operating behaviors

Symbol	Description	Frequency band (MHz)	Typ.	Unit	Notes
V _{RE1}	Radiated emissions voltage, band 1	0.15–50	23	dBμV	1, 2
V _{RE2}	Radiated emissions voltage, band 2	50–150	27	dBμV	
V _{RE3}	Radiated emissions voltage, band 3	150–500	28	dBμV	
V _{RE4}	Radiated emissions voltage, band 4	500–1000	14	dBμV	
V _{RE_IEC}	IEC level	0.15–1000	K	—	2, 3

1. Determined according to IEC Standard 61967-1, *Integrated Circuits - Measurement of Electromagnetic Emissions, 150 kHz to 1 GHz Part 1: General Conditions and Definitions* and IEC Standard 61967-2, *Integrated Circuits - Measurement of Electromagnetic Emissions, 150 kHz to 1 GHz Part 2: Measurement of Radiated Emissions—TEM Cell and Wideband TEM Cell Method*. Measurements were made while the microcontroller was running basic application code.

The reported emission level is the value of the maximum measured emission, rounded up to the next whole number, from among the measured orientations in each frequency range.

2. $V_{DD} = 3.3\text{ V}$, $T_A = 25\text{ °C}$, $f_{OSC} = 12\text{ MHz}$ (crystal), $f_{SYS} = \text{MHz}$, $f_{BUS} = \text{MHz}$
3. Specified according to Annex D of IEC Standard 61967-2, *Measurement of Radiated Emissions—TEM Cell and Wideband TEM Cell Method*

2.2.7 Designing with radiated emissions in mind

To find application notes that provide guidance on designing your system to minimize interference from radiated emissions.

1. Go to nxp.com
2. Perform a keyword search for “EMC design.”

2.2.8 Capacitance attributes

Table 9. Capacitance attributes

Symbol	Description	Min.	Max.	Unit
C_{IN_A}	Input capacitance: analog pins	—	7	pF
C_{IN_D}	Input capacitance: digital pins	—	7	pF

2.3 Switching specifications

2.3.1 Device clock specifications

Table 10. Device clock specifications

Symbol	Description	Min.	Max.	Unit	Notes
High Speed run mode					
f_{SYS}	System and core clock	—	180	MHz	
Normal run mode (and High Speed run mode unless otherwise specified above)					
f_{SYS}	System and core clock	—	120	MHz	
	System and core clock when Full Speed USB in operation	20	—	MHz	
f_{SYS_USBHS}	System and core clock when High Speed USB in operation	100	—	MHz	
f_{ENET}	System and core clock when ethernet in operation			MHz	
	<ul style="list-style-type: none"> • 10 Mbps • 100 Mbps 	5	—		
		50	—		

Table continues on the next page...

Table 10. Device clock specifications (continued)

Symbol	Description	Min.	Max.	Unit	Notes
f _{BUS}	Bus clock	—	60	MHz	
FB_CLK	FlexBus clock	—	60	MHz	
f _{FLASH}	Flash clock	—	28	MHz	
f _{LPTMR}	LPTMR clock	—	25	MHz	
VLPR mode ¹					
f _{SYS}	System and core clock	—	4	MHz	
f _{BUS}	Bus clock	—	4	MHz	
FB_CLK	FlexBus clock	—	4	MHz	
f _{FLASH}	Flash clock	—	1	MHz	
f _{ERCLK}	External reference clock	—	16	MHz	
f _{LPTMR_pin}	LPTMR clock	—	25	MHz	
f _{FlexCAN_ERCLK}	FlexCAN external reference clock	—	8	MHz	
f _{I2S_MCLK}	I2S master clock	—	12.5	MHz	
f _{I2S_BCLK}	I2S bit clock	—	4	MHz	

1. The frequency limitations in VLPR mode here override any frequency specification listed in the timing specification for any other module.

2.3.2 General switching specifications

These general purpose specifications apply to all signals configured for GPIO, UART, CAN, CMT, IEEE 1588 timer, timers, and I²C signals.

Table 11. General switching specifications

Symbol	Description	Min.	Max.	Unit	Notes
	GPIO pin interrupt pulse width (digital glitch filter disabled) — Synchronous path	1.5	—	Bus clock cycles	1, 2
	GPIO pin interrupt pulse width (digital glitch filter disabled, analog filter enabled) — Asynchronous path	100	—	ns	3
	GPIO pin interrupt pulse width (digital glitch filter disabled, analog filter disabled) — Asynchronous path	50	—	ns	3
	External reset pulse width (digital glitch filter disabled)	100	—	ns	3
	Mode select ($\overline{\text{EZP_CS}}$) hold time after reset deassertion	2	—	Bus clock cycles	
	Port rise and fall time (high drive strength)				4
	<ul style="list-style-type: none"> Slew enabled 	—	25	ns	
		—	15	ns	

Table continues on the next page...

Table 11. General switching specifications (continued)

Symbol	Description	Min.	Max.	Unit	Notes
	<ul style="list-style-type: none"> • $1.71 \leq V_{DD} \leq 2.7V$ • $2.7 \leq V_{DD} \leq 3.6V$ • Slew disabled • $1.71 \leq V_{DD} \leq 2.7V$ • $2.7 \leq V_{DD} \leq 3.6V$ 	—	7	ns	
	<ul style="list-style-type: none"> • Slew disabled • $1.71 \leq V_{DD} \leq 2.7V$ • $2.7 \leq V_{DD} \leq 3.6V$ 	—	7	ns	
	Port rise and fall time (low drive strength)				5
	<ul style="list-style-type: none"> • Slew enabled • $1.71 \leq V_{DD} \leq 2.7V$ • $2.7 \leq V_{DD} \leq 3.6V$ 	—	25	ns	
	<ul style="list-style-type: none"> • Slew enabled • $1.71 \leq V_{DD} \leq 2.7V$ • $2.7 \leq V_{DD} \leq 3.6V$ 	—	15	ns	
	<ul style="list-style-type: none"> • Slew disabled • $1.71 \leq V_{DD} \leq 2.7V$ • $2.7 \leq V_{DD} \leq 3.6V$ 	—	7	ns	
	<ul style="list-style-type: none"> • Slew disabled • $1.71 \leq V_{DD} \leq 2.7V$ • $2.7 \leq V_{DD} \leq 3.6V$ 	—	7	ns	

1. This is the minimum pulse width that is guaranteed to pass through the pin synchronization circuitry. Shorter pulses may or may not be recognized. In Stop, VLPS, LLS, and VLLSx modes, the synchronizer is bypassed so shorter pulses can be recognized in that case.
2. The greater synchronous and asynchronous timing must be met.
3. This is the minimum pulse width that is guaranteed to be recognized as a pin interrupt request in Stop, VLPS, LLS, and VLLSx modes.
4. 75 pF load
5. 15 pF load

2.4 Thermal specifications

2.4.1 Thermal operating requirements

Table 12. Thermal operating requirements

Symbol	Description	Min.	Max.	Unit	Notes
T_J	Die junction temperature	-40	125	°C	
T_A	Ambient temperature	-40	105	°C	1

1. Maximum T_A can be exceeded only if the user ensures that T_J does not exceed maximum T_J . The simplest method to determine T_J is: $T_J = T_A + R_{\theta JA} \times \text{chip power dissipation}$.

2.4.2 Thermal attributes

Board type	Symbol	Description	144 LQFP	144 MAPBGA	Unit	Notes
Single-layer (1s)	$R_{\theta JA}$	Thermal resistance, junction to ambient (natural convection)	45	48	°C/W	1
Four-layer (2s2p)	$R_{\theta JA}$	Thermal resistance, junction to ambient (natural convection)	36	29	°C/W	1
Single-layer (1s)	$R_{\theta JMA}$	Thermal resistance, junction to ambient (200 ft./min. air speed)	36	38	°C/W	1
Four-layer (2s2p)	$R_{\theta JMA}$	Thermal resistance, junction to ambient (200 ft./min. air speed)	30	25	°C/W	1
—	$R_{\theta JB}$	Thermal resistance, junction to board	24	16	°C/W	2
—	$R_{\theta JC}$	Thermal resistance, junction to case	9	9	°C/W	3
—	Ψ_{JT}	Thermal characterization parameter, junction to package top outside center (natural convection)	2	2	°C/W	4

1. Determined according to JEDEC Standard JESD51-2, *Integrated Circuits Thermal Test Method Environmental Conditions—Natural Convection (Still Air)*, or EIA/JEDEC Standard JESD51-6, *Integrated Circuit Thermal Test Method Environmental Conditions—Forced Convection (Moving Air)*.
2. Determined according to JEDEC Standard JESD51-8, *Integrated Circuit Thermal Test Method Environmental Conditions—Junction-to-Board*.
3. Determined according to Method 1012.1 of MIL-STD 883, *Test Method Standard, Microcircuits*, with the cold plate temperature used for the case temperature. The value includes the thermal resistance of the interface material between the top of the package and the cold plate.
4. Determined according to JEDEC Standard JESD51-2, *Integrated Circuits Thermal Test Method Environmental Conditions—Natural Convection (Still Air)*.

3 Peripheral operating requirements and behaviors

3.1 Core modules

3.1.1 Debug trace timing specifications

Table 13. Debug trace operating behaviors

Symbol	Description	Min.	Max.	Unit
T_{cyc}	Clock period	Frequency dependent		MHz
T_{wl}	Low pulse width	2	—	ns
T_{wh}	High pulse width	2	—	ns
T_r	Clock and data rise time	—	3	ns
T_f	Clock and data fall time	—	3	ns
T_s	Data setup	1.5	—	ns
T_h	Data hold	1.0	—	ns

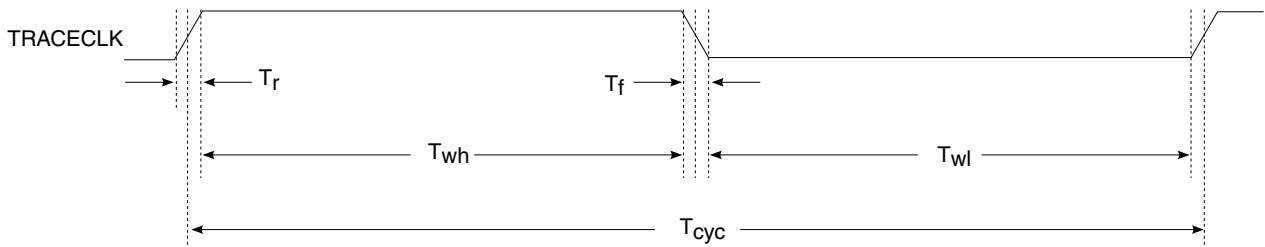

Figure 5. TRACE_CLKOUT specifications

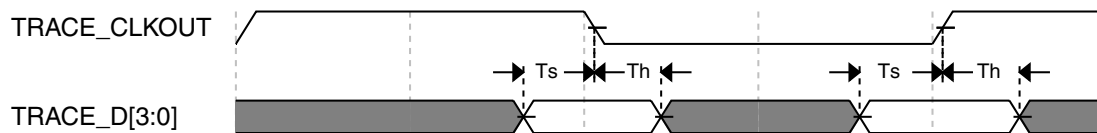

Figure 6. Trace data specifications

3.1.2 JTAG electricals

Table 14. JTAG limited voltage range electricals

Symbol	Description	Min.	Max.	Unit
	Operating voltage	2.7	3.6	V
J1	TCLK frequency of operation <ul style="list-style-type: none"> • Boundary Scan • JTAG and CJTAG • Serial Wire Debug 	0 0 0	10 25 50	MHz
J2	TCLK cycle period	1/J1	—	ns
J3	TCLK clock pulse width <ul style="list-style-type: none"> • Boundary Scan • JTAG and CJTAG • Serial Wire Debug 	50 20 10	— — —	ns ns ns
J4	TCLK rise and fall times	—	3	ns
J5	Boundary scan input data setup time to TCLK rise	20	—	ns
J6	Boundary scan input data hold time after TCLK rise	2.0	—	ns
J7	TCLK low to boundary scan output data valid	—	28	ns
J8	TCLK low to boundary scan output high-Z	—	25	ns
J9	TMS, TDI input data setup time to TCLK rise	8	—	ns
J10	TMS, TDI input data hold time after TCLK rise	1	—	ns
J11	TCLK low to TDO data valid	—	19	ns
J12	TCLK low to TDO high-Z	—	17	ns
J13	$\overline{\text{TRST}}$ assert time	100	—	ns
J14	$\overline{\text{TRST}}$ setup time (negation) to TCLK high	8	—	ns

Table 15. JTAG full voltage range electricals

Symbol	Description	Min.	Max.	Unit
	Operating voltage	1.71	3.6	V
J1	TCLK frequency of operation <ul style="list-style-type: none"> • Boundary Scan • JTAG and CJTAG • Serial Wire Debug 	0 0 0	10 20 40	MHz
J2	TCLK cycle period	1/J1	—	ns
J3	TCLK clock pulse width <ul style="list-style-type: none"> • Boundary Scan • JTAG and CJTAG • Serial Wire Debug 	50 25 12.5	— — —	ns ns ns

Table continues on the next page...

Table 15. JTAG full voltage range electricals (continued)

Symbol	Description	Min.	Max.	Unit
J4	TCLK rise and fall times	—	3	ns
J5	Boundary scan input data setup time to TCLK rise	20	—	ns
J6	Boundary scan input data hold time after TCLK rise	2.0	—	ns
J7	TCLK low to boundary scan output data valid	—	30.6	ns
J8	TCLK low to boundary scan output high-Z	—	25	ns
J9	TMS, TDI input data setup time to TCLK rise	8	—	ns
J10	TMS, TDI input data hold time after TCLK rise	1.0	—	ns
J11	TCLK low to TDO data valid	—	19.0	ns
J12	TCLK low to TDO high-Z	—	17.0	ns
J13	$\overline{\text{TRST}}$ assert time	100	—	ns
J14	$\overline{\text{TRST}}$ setup time (negation) to TCLK high	8	—	ns

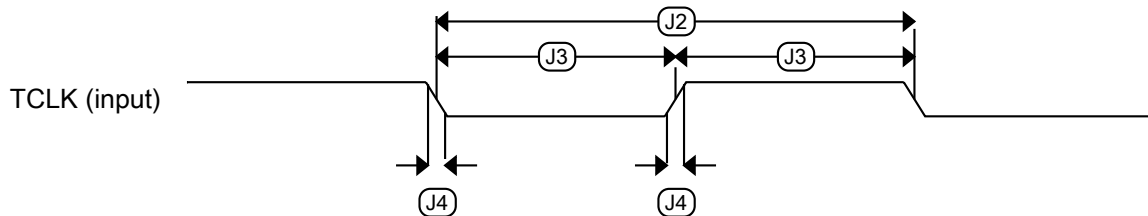
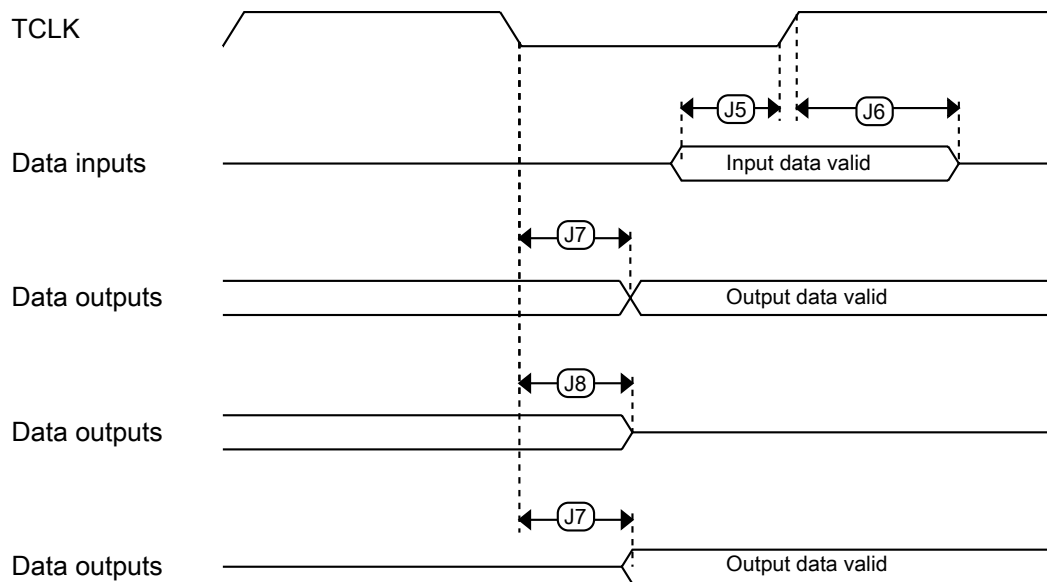
**Figure 7. Test clock input timing****Figure 8. Boundary scan (JTAG) timing**

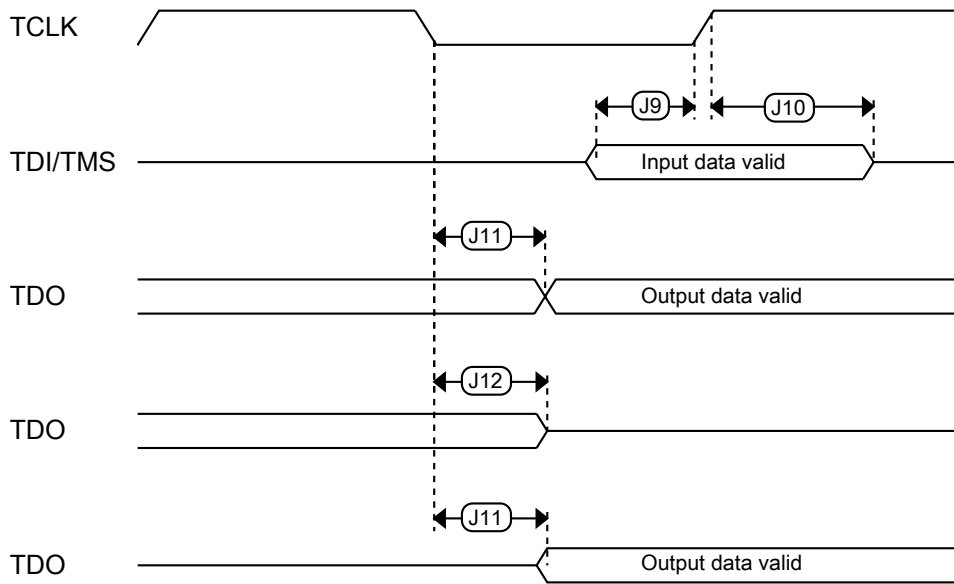

Figure 9. Test Access Port timing

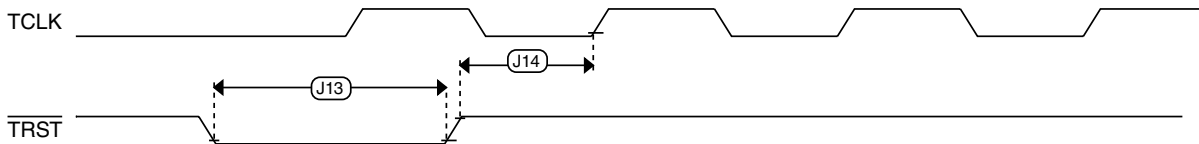

Figure 10. TRST timing

3.2 System modules

There are no specifications necessary for the device's system modules.

3.3 Clock modules

3.3.1 MCG specifications

Table 16. MCG specifications

Symbol	Description	Min.	Typ.	Max.	Unit	Notes	
f_{ints_ft}	Internal reference frequency (slow clock) — factory trimmed at nominal VDD and 25 °C	—	32.768	—	kHz		
f_{ints_t}	Internal reference frequency (slow clock) — user trimmed	31.25	—	39.0625	kHz		
I_{ints}	Internal reference (slow clock) current	—	20	—	μA		
$\Delta f_{dco_res_t}$	Resolution of trimmed average DCO output frequency at fixed voltage and temperature — using SCTRIM and SCFTRIM	—	± 0.3	± 0.6	% f_{dco}	1	
$\Delta f_{dco_res_t}$	Resolution of trimmed average DCO output frequency at fixed voltage and temperature — using SCTRIM only	—	± 0.2	± 0.5	% f_{dco}	1	
Δf_{dco_t}	Total deviation of trimmed average DCO output frequency over voltage and temperature	—	± 0.5	± 2	% f_{dco}	1	
Δf_{dco_t}	Total deviation of trimmed average DCO output frequency over fixed voltage and temperature range of 0–70°C	—	± 0.3	1.5	% f_{dco}	1	
f_{intf_ft}	Internal reference frequency (fast clock) — factory trimmed at nominal VDD and 25°C	—	4	—	MHz		
f_{intf_t}	Internal reference frequency (fast clock) — user trimmed at nominal VDD and 25 °C	3	—	5	MHz		
I_{intf}	Internal reference (fast clock) current	—	25	—	μA		
f_{loc_low}	Loss of external clock minimum frequency — RANGE = 00 ext clk freq: above $(3/5)f_{int}$ never reset ext clk freq: between $(2/5)f_{int}$ and $(3/5)f_{int}$ maybe reset (phase dependency) ext clk freq: below $(2/5)f_{int}$ always reset	$(3/5) \times f_{ints_t}$	—	—	kHz		
f_{loc_high}	Loss of external clock minimum frequency — RANGE = 01, 10, or 11 ext clk freq: above $(16/5)f_{int}$ never reset ext clk freq: between $(15/5)f_{int}$ and $(16/5)f_{int}$ maybe reset (phase dependency) ext clk freq: below $(15/5)f_{int}$ always reset	$(16/5) \times f_{ints_t}$	—	—	kHz		
FLL							
f_{fill_ref}	FLL reference frequency range	31.25	—	39.0625	kHz		
f_{dco_ut}	DCO output frequency range — untrimmed	Low range (DRS=00, DMX32=0) $640 \times f_{ints_ut}$	16.0	23.04	26.66	MHz	2
		Mid range (DRS=01, DMX32=0) $1280 \times f_{ints_ut}$	32.0	46.08	53.32		

Table continues on the next page...

Table 16. MCG specifications (continued)

Symbol	Description	Min.	Typ.	Max.	Unit	Notes	
		Mid-high range (DRS=10, DMX32=0) $1920 \times f_{\text{ints_ut}}$	48.0	69.12	79.99		
		High range (DRS=11, DMX32=0) $2560 \times f_{\text{ints_ut}}$	64.0	92.16	106.65		
		Low range (DRS=00, DMX32=1) $732 \times f_{\text{ints_ut}}$	18.3	26.35	30.50		
		Mid range (DRS=01, DMX32=1) $1464 \times f_{\text{ints_ut}}$	36.6	52.70	60.99		
		Mid-high range (DRS=10, DMX32=1) $2197 \times f_{\text{ints_ut}}$	54.93	79.09	91.53		
		High range (DRS=11, DMX32=1) $2929 \times f_{\text{ints_ut}}$	73.23	105.44	122.02		
f_{dco}	DCO output frequency range	Low range (DRS=00) $640 \times f_{\text{fill_ref}}$	20	20.97	25	MHz	3, 4
		Mid range (DRS=01) $1280 \times f_{\text{fill_ref}}$	40	41.94	50	MHz	
		Mid-high range (DRS=10) $1920 \times f_{\text{fill_ref}}$	60	62.91	75	MHz	
		High range (DRS=11) $2560 \times f_{\text{fill_ref}}$	80	83.89	100	MHz	
$f_{\text{dco_t_DMX32}}$	DCO output frequency	Low range (DRS=00) $732 \times f_{\text{fill_ref}}$	—	23.99	—	MHz	5, 6
		Mid range (DRS=01) $1464 \times f_{\text{fill_ref}}$	—	47.97	—	MHz	
		Mid-high range (DRS=10) $2197 \times f_{\text{fill_ref}}$	—	71.99	—	MHz	
		High range (DRS=11) $2929 \times f_{\text{fill_ref}}$	—	95.98	—	MHz	
$J_{\text{cyc_fill}}$	FLL period jitter		—	180	—	ps	
		<ul style="list-style-type: none"> • $f_{\text{DCO}} = 48 \text{ MHz}$ • $f_{\text{DCO}} = 98 \text{ MHz}$ 	—	150	—		

Table continues on the next page...

Table 16. MCG specifications (continued)

Symbol	Description	Min.	Typ.	Max.	Unit	Notes
$t_{\text{fill_acquire}}$	FLL target frequency acquisition time	—	—	1	ms	7
PLL						
$f_{\text{pll_ref}}$	PLL reference frequency range	8	—	16	MHz	
$f_{\text{vcoclk_2x}}$	VCO output frequency	180	—	360	MHz	
f_{vcoclk}	PLL output frequency	90	—	180	MHz	
$f_{\text{vcoclk_90}}$	PLL quadrature output frequency	90	—	180	MHz	
I_{pll}	PLL operating current <ul style="list-style-type: none"> VCO @ 184 MHz ($f_{\text{osc_hi_1}} = 32$ MHz, $f_{\text{pll_ref}} = 8$ MHz, VDIV multiplier = 23) 	—	2.8	—	mA	8
I_{pll}	PLL operating current <ul style="list-style-type: none"> VCO @ 360 MHz ($f_{\text{osc_hi_1}} = 32$ MHz, $f_{\text{pll_ref}} = 8$ MHz, VDIV multiplier = 45) 	—	3.6	—	mA	8
$J_{\text{cyc_pll}}$	PLL period jitter (RMS) <ul style="list-style-type: none"> $f_{\text{vco}} = 180$ MHz $f_{\text{vco}} = 360$ MHz 	—	100	—	ps	9
$J_{\text{acc_pll}}$	PLL accumulated jitter over 1 μ s (RMS) <ul style="list-style-type: none"> $f_{\text{vco}} = 180$ MHz $f_{\text{vco}} = 360$ MHz 	—	600	—	ps	9
D_{unl}	Lock exit frequency tolerance	± 4.47	—	± 5.97	%	
$t_{\text{pll_lock}}$	Lock detector detection time	—	—	$150 \times 10^{-6} + 1075(1/f_{\text{pll_ref}})$	s	10

1. This parameter is measured with the internal reference (slow clock) being used as a reference to the FLL (FEI clock mode).
2. This applies when SCTRIM at value (0x80) and SCFTRIM control bit at value (0x0).
3. These typical values listed are with the slow internal reference clock (FEI) using factory trim and DMX32=0.
4. The resulting system clock frequencies should not exceed their maximum specified values. The DCO frequency deviation ($\Delta f_{\text{dco_t}}$) over voltage and temperature should be considered.
5. These typical values listed are with the slow internal reference clock (FEI) using factory trim and DMX32=1.
6. The resulting clock frequency must not exceed the maximum specified clock frequency of the device.
7. This specification applies to any time the FLL reference source or reference divider is changed, trim value is changed, DMX32 bit is changed, DRS bits are changed, or changing from FLL disabled (BLPE, BLPI) to FLL enabled (FEI, FEE, FBE, FBI). If a crystal/resonator is being used as the reference, this specification assumes it is already running.
8. Excludes any oscillator currents that are also consuming power while PLL is in operation.
9. This specification was obtained using a NXP developed PCB. PLL jitter is dependent on the noise characteristics of each PCB and results will vary.
10. This specification applies to any time the PLL VCO divider or reference divider is changed, or changing from PLL disabled (BLPE, BLPI) to PLL enabled (PBE, PEE). If a crystal/resonator is being used as the reference, this specification assumes it is already running.

3.3.2 IRC48M specifications

Table 17. IRC48M specifications

Symbol	Description	Min.	Typ.	Max.	Unit	Notes
V _{DD}	Supply voltage	1.71	—	3.6	V	
I _{DD48M}	Supply current	—	520	—	μA	
f _{irc48m}	Internal reference frequency	—	48	—	MHz	
Δf _{irc48m_ol_lv}	Open loop total deviation of IRC48M frequency at low voltage (VDD=1.71V-1.89V) over full temperature <ul style="list-style-type: none"> • Regulator disable (USB_CLK_RECOVER_IRC_EN[REG_EN]=0) • Regulator enable (USB_CLK_RECOVER_IRC_EN[REG_EN]=1) 	—	± 0.4	± 1.0	%f _{irc48m}	1
Δf _{irc48m_ol_hv}	Open loop total deviation of IRC48M frequency at high voltage (VDD=1.89V-3.6V) over 0—70°C <ul style="list-style-type: none"> • Regulator enable (USB_CLK_RECOVER_IRC_EN[REG_EN]=1) 	—	± 0.2	± 0.5	%f _{irc48m}	1
Δf _{irc48m_ol_hv}	Open loop total deviation of IRC48M frequency at high voltage (VDD=1.89V-3.6V) over full temperature <ul style="list-style-type: none"> • Regulator enable (USB_CLK_RECOVER_IRC_EN[REG_EN]=1) 	—	± 0.4	± 1.0	%f _{irc48m}	1
Δf _{irc48m_cl}	Closed loop total deviation of IRC48M frequency over voltage and temperature	—	—	± 0.1	%f _{host}	2
J _{cyc_irc48m}	Period Jitter (RMS)	—	35	150	ps	
t _{irc48mst}	Startup time	—	2	3	μs	3

1. The maximum value represents characterized results equivalent to mean plus or minus three times the standard deviation (mean ± 3 sigma)
2. Closed loop operation of the IRC48M is only feasible for USB device operation; it is not usable for USB host operation. It is enabled by configuring for USB Device, selecting IRC48M as USB clock source, and enabling the clock recover function (USB_CLK_RECOVER_IRC_CTRL[CLOCK_RECOVER_EN]=1, USB_CLK_RECOVER_IRC_EN[IRC_EN]=1).
3. IRC48M startup time is defined as the time between clock enablement and clock availability for system use. Enable the clock by one of the following settings:
 - USB_CLK_RECOVER_IRC_EN[IRC_EN]=1, or
 - MCG_C7[OSCSEL]=10, or
 - SIM_SOPT2[PLLFLSEL]=11

3.3.3 Oscillator electrical specifications

3.3.3.1 Oscillator DC electrical specifications

Table 18. Oscillator DC electrical specifications

Symbol	Description	Min.	Typ.	Max.	Unit	Notes
V _{DD}	Supply voltage	1.71	—	3.6	V	
I _{DDOSC}	Supply current — low-power mode (HGO=0) <ul style="list-style-type: none"> • 32 kHz • 4 MHz • 8 MHz (RANGE=01) • 16 MHz • 24 MHz • 32 MHz 	—	600	—	nA	1
		—	200	—	μA	
		—	300	—	μA	
		—	950	—	μA	
		—	1.2	—	mA	
		—	1.5	—	mA	
I _{DDOSC}	Supply current — high gain mode (HGO=1) <ul style="list-style-type: none"> • 32 kHz • 4 MHz • 8 MHz (RANGE=01) • 16 MHz • 24 MHz • 32 MHz 	—	7.5	—	μA	1
		—	500	—	μA	
		—	650	—	μA	
		—	2.5	—	mA	
		—	3.25	—	mA	
		—	4	—	mA	
C _x	EXTAL load capacitance	—	—	—		2, 3
C _y	XTAL load capacitance	—	—	—		2, 3
R _F	Feedback resistor — low-frequency, low-power mode (HGO=0)	—	—	—	MΩ	2, 4
	Feedback resistor — low-frequency, high-gain mode (HGO=1)	—	10	—	MΩ	
	Feedback resistor — high-frequency, low-power mode (HGO=0)	—	—	—	MΩ	
	Feedback resistor — high-frequency, high-gain mode (HGO=1)	—	1	—	MΩ	
R _S	Series resistor — low-frequency, low-power mode (HGO=0)	—	—	—	kΩ	
	Series resistor — low-frequency, high-gain mode (HGO=1)	—	200	—	kΩ	
	Series resistor — high-frequency, low-power mode (HGO=0)	—	—	—	kΩ	
	Series resistor — high-frequency, high-gain mode (HGO=1)	—	0	—	kΩ	
V _{pp} ⁵	Peak-to-peak amplitude of oscillation (oscillator mode) — low-frequency, low-power mode (HGO=0)	—	0.6	—	V	

Table continues on the next page...

Table 18. Oscillator DC electrical specifications (continued)

Symbol	Description	Min.	Typ.	Max.	Unit	Notes
	Peak-to-peak amplitude of oscillation (oscillator mode) — low-frequency, high-gain mode (HGO=1)	—	V _{DD}	—	V	
	Peak-to-peak amplitude of oscillation (oscillator mode) — high-frequency, low-power mode (HGO=0)	—	0.6	—	V	
	Peak-to-peak amplitude of oscillation (oscillator mode) — high-frequency, high-gain mode (HGO=1)	—	V _{DD}	—	V	

1. V_{DD}=3.3 V, Temperature =25 °C, Internal capacitance = 20 pf
2. See crystal or resonator manufacturer's recommendation
3. C_x, C_y can be provided by using either the integrated capacitors or by using external components.
4. When low power mode is selected, R_F is integrated and must not be attached externally.
5. The EXTAL and XTAL pins should only be connected to required oscillator components and must not be connected to any other devices.

3.3.3.2 Oscillator frequency specifications

Table 19. Oscillator frequency specifications

Symbol	Description	Min.	Typ.	Max.	Unit	Notes
f _{osc_lo}	Oscillator crystal or resonator frequency — low-frequency mode (MCG_C2[RANGE]=00)	32	—	40	kHz	
f _{osc_hi_1}	Oscillator crystal or resonator frequency — high-frequency mode (low range) (MCG_C2[RANGE]=01)	3	—	8	MHz	
f _{osc_hi_2}	Oscillator crystal or resonator frequency — high frequency mode (high range) (MCG_C2[RANGE]=1x)	8	—	32	MHz	
f _{ec_extal}	Input clock frequency (external clock mode)	—	—	50	MHz	1, 2
t _{dc_extal}	Input clock duty cycle (external clock mode)	40	50	60	%	
t _{cst}	Crystal startup time — 32 kHz low-frequency, low-power mode (HGO=0)	—	750	—	ms	3, 4
	Crystal startup time — 32 kHz low-frequency, high-gain mode (HGO=1)	—	250	—	ms	
	Crystal startup time — 8 MHz high-frequency (MCG_C2[RANGE]=01), low-power mode (HGO=0)	—	0.6	—	ms	
	Crystal startup time — 8 MHz high-frequency (MCG_C2[RANGE]=01), high-gain mode (HGO=1)	—	1	—	ms	

1. Other frequency limits may apply when external clock is being used as a reference for the FLL or PLL.
2. When transitioning from FEI or FBI to FBE mode, restrict the frequency of the input clock so that, when it is divided by FRDIV, it remains within the limits of the DCO input clock frequency.
3. Proper PC board layout procedures must be followed to achieve specifications.

- Crystal startup time is defined as the time between the oscillator being enabled and the OSCINIT bit in the MCG_S register being set.

NOTE

The 32 kHz oscillator works in low power mode by default and cannot be moved into high power/gain mode.

3.3.4 32 kHz oscillator electrical characteristics

3.3.4.1 32 kHz oscillator DC electrical specifications

Table 20. 32kHz oscillator DC electrical specifications

Symbol	Description	Min.	Typ.	Max.	Unit
V_{BAT}	Supply voltage	1.71	—	3.6	V
R_F	Internal feedback resistor	—	100	—	$M\Omega$
C_{para}	Parasitical capacitance of EXTAL32 and XTAL32	—	5	7	pF
V_{pp} ¹	Peak-to-peak amplitude of oscillation	—	0.6	—	V

- When a crystal is being used with the 32 kHz oscillator, the EXTAL32 and XTAL32 pins should only be connected to required oscillator components and must not be connected to any other devices.

3.3.4.2 32 kHz oscillator frequency specifications

Table 21. 32 kHz oscillator frequency specifications

Symbol	Description	Min.	Typ.	Max.	Unit	Notes
f_{osc_lo}	Oscillator crystal	—	32.768	—	kHz	
t_{start}	Crystal start-up time	—	1000	—	ms	1
$f_{ec_extal32}$	Externally provided input clock frequency	—	32.768	—	kHz	2
$V_{ec_extal32}$	Externally provided input clock amplitude	700	—	V_{BAT}	mV	2, 3

- Proper PC board layout procedures must be followed to achieve specifications.
- This specification is for an externally supplied clock driven to EXTAL32 and does not apply to any other clock input. The oscillator remains enabled and XTAL32 must be left unconnected.
- The parameter specified is a peak-to-peak value and V_{IH} and V_{IL} specifications do not apply. The voltage of the applied clock must be within the range of V_{SS} to V_{BAT} .

3.4 Memories and memory interfaces

3.4.1 Flash (FTFE) electrical specifications

This section describes the electrical characteristics of the FTFE module.

3.4.1.1 Flash timing specifications — program and erase

The following specifications represent the amount of time the internal charge pumps are active and do not include command overhead.

Table 22. NVM program/erase timing specifications

Symbol	Description	Min.	Typ.	Max.	Unit	Notes
$t_{hvp\text{pgm}8}$	Program Phrase high-voltage time	—	7.5	18	μs	
$t_{h\text{versscr}}$	Erase Flash Sector high-voltage time	—	13	113	ms	1
$t_{h\text{versblk}256\text{k}}$	Erase Flash Block high-voltage time for 256 KB	—	208	1808	ms	1
$t_{h\text{versblk}512\text{k}}$	Erase Flash Block high-voltage time for 512 KB	—	416	3616	ms	1

1. Maximum time based on expectations at cycling end-of-life.

3.4.1.2 Flash timing specifications — commands

Table 23. Flash command timing specifications

Symbol	Description	Min.	Typ.	Max.	Unit	Notes
$t_{rd1\text{blk}256\text{k}}$	Read 1s Block execution time					
	• 256 KB data flash	—	—	1.0	ms	
$t_{rd1\text{blk}512\text{k}}$	• 512 KB program flash	—	—	1.8	ms	
$t_{rd1\text{sec}4\text{k}}$	Read 1s Section execution time (4 KB flash)	—	—	100	μs	1
$t_{pgm\text{chk}}$	Program Check execution time	—	—	95	μs	1
$t_{rd\text{rsrc}}$	Read Resource execution time	—	—	40	μs	1
t_{pgm8}	Program Phrase execution time	—	90	150	μs	
$t_{ers\text{blk}256\text{k}}$	Erase Flash Block execution time					2
	• 256 KB data flash	—	220	1850	ms	
$t_{ers\text{blk}512\text{k}}$	• 512 KB program flash	—	435	3700	ms	
$t_{ers\text{scr}}$	Erase Flash Sector execution time	—	15	115	ms	2
$t_{pgm\text{sec}1\text{k}}$	Program Section execution time (1 KB flash)	—	5	—	ms	
$t_{rd1\text{allx}}$	Read 1s All Blocks execution time					
	• FlexNVM devices	—	—	5.9	ms	
$t_{rd1\text{alln}}$	• Program flash only devices	—	—	6.7	ms	
$t_{rd\text{once}}$	Read Once execution time	—	—	30	μs	1
$t_{pgm\text{once}}$	Program Once execution time	—	90	—	μs	
$t_{ers\text{all}}$	Erase All Blocks execution time	—	1750	14,800	ms	2

Table continues on the next page...

Table 23. Flash command timing specifications (continued)

Symbol	Description	Min.	Typ.	Max.	Unit	Notes
t_{vfykey}	Verify Backdoor Access Key execution time	—	—	30	μs	1
	Swap Control execution time					
t_{swapx01}	• control code 0x01	—	200	—	μs	
t_{swapx02}	• control code 0x02	—	90	150	μs	
t_{swapx04}	• control code 0x04	—	90	150	μs	
t_{swapx08}	• control code 0x08	—	—	30	μs	
t_{swapx10}	• control code 0x10	—	90	150	μs	
	Program Partition for EEPROM execution time					
$t_{\text{pgmpart32k}}$	• 32 KB EEPROM backup	—	70	—	ms	
$t_{\text{pgmpart256k}}$	• 256 KB EEPROM backup	—	78	—	ms	
	Set FlexRAM Function execution time:					
t_{setramff}	• Control Code 0xFF	—	70	—	μs	
$t_{\text{setram32k}}$	• 32 KB EEPROM backup	—	0.8	1.2	ms	
$t_{\text{setram64k}}$	• 64 KB EEPROM backup	—	1.3	1.9	ms	
$t_{\text{setram128k}}$	• 128 KB EEPROM backup	—	2.4	3.1	ms	
$t_{\text{setram256k}}$	• 256 KB EEPROM backup	—	4.5	5.5	ms	
	Byte-write to FlexRAM execution time:					
$t_{\text{eewr8b32k}}$	• 32 KB EEPROM backup	—	385	1700	μs	
$t_{\text{eewr8b64k}}$	• 64 KB EEPROM backup	—	475	2000	μs	
$t_{\text{eewr8b128k}}$	• 128 KB EEPROM backup	—	650	2350	μs	
$t_{\text{eewr8b256k}}$	• 256 KB EEPROM backup	—	1000	3250	μs	
	16-bit write to FlexRAM execution time:					
$t_{\text{eewr16b32k}}$	• 32 KB EEPROM backup	—	385	1700	μs	
$t_{\text{eewr16b64k}}$	• 64 KB EEPROM backup	—	475	2000	μs	
$t_{\text{eewr16b128k}}$	• 128 KB EEPROM backup	—	650	2350	μs	
$t_{\text{eewr16b256k}}$	• 256 KB EEPROM backup	—	1000	3250	μs	
$t_{\text{eewr32bers}}$	32-bit write to erased FlexRAM location execution time	—	360	1500	μs	
	32-bit write to FlexRAM execution time:					
$t_{\text{eewr32b32k}}$	• 32 KB EEPROM backup	—	630	2000	μs	
$t_{\text{eewr32b64k}}$	• 64 KB EEPROM backup	—	810	2250	μs	
$t_{\text{eewr32b128k}}$	• 128 KB EEPROM backup	—	1200	2650	μs	
$t_{\text{eewr32b256k}}$	• 256 KB EEPROM backup	—	1900	3500	μs	

1. Assumes 25MHz or greater flash clock frequency.
2. Maximum times for erase parameters based on expectations at cycling end-of-life.

3.4.1.3 Flash high voltage current behaviors

Table 24. Flash high voltage current behaviors

Symbol	Description	Min.	Typ.	Max.	Unit
I _{DD_PGM}	Average current adder during high voltage flash programming operation	—	3.5	7.5	mA
I _{DD_ERS}	Average current adder during high voltage flash erase operation	—	1.5	4.0	mA

3.4.1.4 Reliability specifications

Table 25. NVM reliability specifications

Symbol	Description	Min.	Typ. ¹	Max.	Unit	Notes
Program Flash						
t _{nvmretp10k}	Data retention after up to 10 K cycles	5	50	—	years	
t _{nvmretp1k}	Data retention after up to 1 K cycles	20	100	—	years	
n _{nvmcyccp}	Cycling endurance	10 K	50 K	—	cycles	2
Data Flash						
t _{nvmretd10k}	Data retention after up to 10 K cycles	5	50	—	years	
t _{nvmretd1k}	Data retention after up to 1 K cycles	20	100	—	years	
n _{nvmcyccd}	Cycling endurance	10 K	50 K	—	cycles	2
FlexRAM as EEPROM						
t _{nvmretee100}	Data retention up to 100% of write endurance	5	50	—	years	
t _{nvmretee10}	Data retention up to 10% of write endurance	20	100	—	years	
n _{nvmcycee}	Cycling endurance for EEPROM backup	20 K	50 K	—	cycles	2
n _{nvmwree16}	Write endurance • EEPROM backup to FlexRAM ratio = 16	140 K	400 K	—	writes	3
n _{nvmwree128}	• EEPROM backup to FlexRAM ratio = 128	1.26 M	3.2 M	—	writes	
n _{nvmwree512}	• EEPROM backup to FlexRAM ratio = 512	5 M	12.8 M	—	writes	
n _{nvmwree2k}	• EEPROM backup to FlexRAM ratio = 2,048	20 M	50 M	—	writes	
n _{nvmwree8k}	• EEPROM backup to FlexRAM ratio = 8,192	80 M	200 M	—	writes	

1. Typical data retention values are based on measured response accelerated at high temperature and derated to a constant 25°C use profile. Engineering Bulletin EB618 does not apply to this technology. Typical endurance defined in Engineering Bulletin EB619.
2. Cycling endurance represents number of program/erase cycles at $-40^{\circ}\text{C} \leq T_j \leq 125^{\circ}\text{C}$.
3. Write endurance represents the number of writes to each FlexRAM location at $-40^{\circ}\text{C} \leq T_j \leq 125^{\circ}\text{C}$ influenced by the cycling endurance of the FlexNVM and the allocated EEPROM backup per subsystem. Minimum and typical values assume all 16-bit or 32-bit writes to FlexRAM; all 8-bit writes result in 50% less endurance.

3.4.1.5 Write endurance to FlexRAM for EEPROM

When the FlexNVM partition code is not set to full data flash, the EEPROM data set size can be set to any of several non-zero values.

The bytes not assigned to data flash via the FlexNVM partition code are used by the FTFE to obtain an effective endurance increase for the EEPROM data. The built-in EEPROM record management system raises the number of program/erase cycles that can be attained prior to device wear-out by cycling the EEPROM data through a larger EEPROM NVM storage space.

While different partitions of the FlexNVM are available, the intention is that a single choice for the FlexNVM partition code and EEPROM data set size is used throughout the entire lifetime of a given application. The EEPROM endurance equation and graph shown below assume that only one configuration is ever used.

$$\text{Writes_subsystem} = \frac{\text{EEPROM} - 2 \times \text{EEESPLIT} \times \text{EEESIZE}}{\text{EEESPLIT} \times \text{EEESIZE}} \times \text{Write_efficiency} \times n_{\text{nvmcycee}}$$

where

- Writes_subsystem — minimum number of writes to each FlexRAM location for subsystem (each subsystem can have different endurance)
- EEPROM — allocated FlexNVM for each EEPROM subsystem based on DEPART; entered with the Program Partition command
- EEESPLIT — FlexRAM split factor for subsystem; entered with the Program Partition command
- EEESIZE — allocated FlexRAM based on DEPART; entered with the Program Partition command
- Write_efficiency —
 - 0.25 for 8-bit writes to FlexRAM
 - 0.50 for 16-bit or 32-bit writes to FlexRAM
- n_{nvmcycee} — EEPROM-backup cycling endurance

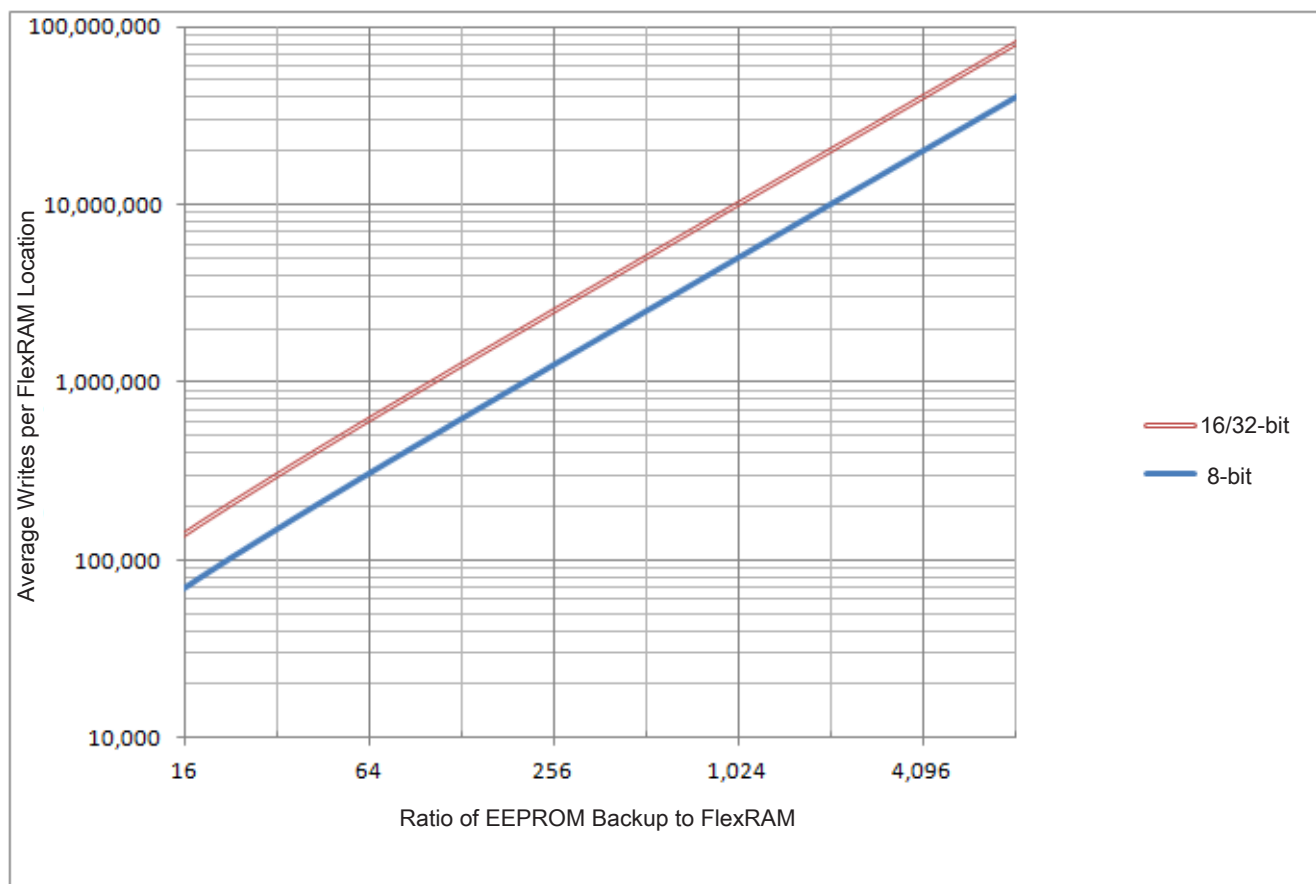

Figure 11. EEPROM backup writes to FlexRAM

3.4.2 EzPort switching specifications

Table 26. EzPort full voltage range switching specifications

Num	Description	Min.	Max.	Unit
	Operating voltage	1.71	3.6	V
EP1	EZP_CK frequency of operation (all commands except READ)	—	$f_{SYS}/2$	MHz
EP1a	EZP_CK frequency of operation (READ command)	—	$f_{SYS}/8$	MHz
EP2	$\overline{EZP_CS}$ negation to next $\overline{EZP_CS}$ assertion	$2 \times t_{EZP_CK}$	—	ns
EP3	EZP_CS input valid to EZP_CK high (setup)	5	—	ns
EP4	EZP_CK high to $\overline{EZP_CS}$ input invalid (hold)	5	—	ns
EP5	EZP_D input valid to EZP_CK high (setup)	2	—	ns
EP6	EZP_CK high to EZP_D input invalid (hold)	5	—	ns
EP7	EZP_CK low to EZP_Q output valid	—	14	ns
EP8	EZP_CK low to EZP_Q output invalid (hold)	0	—	ns
EP9	$\overline{EZP_CS}$ negation to EZP_Q tri-state	—	12	ns

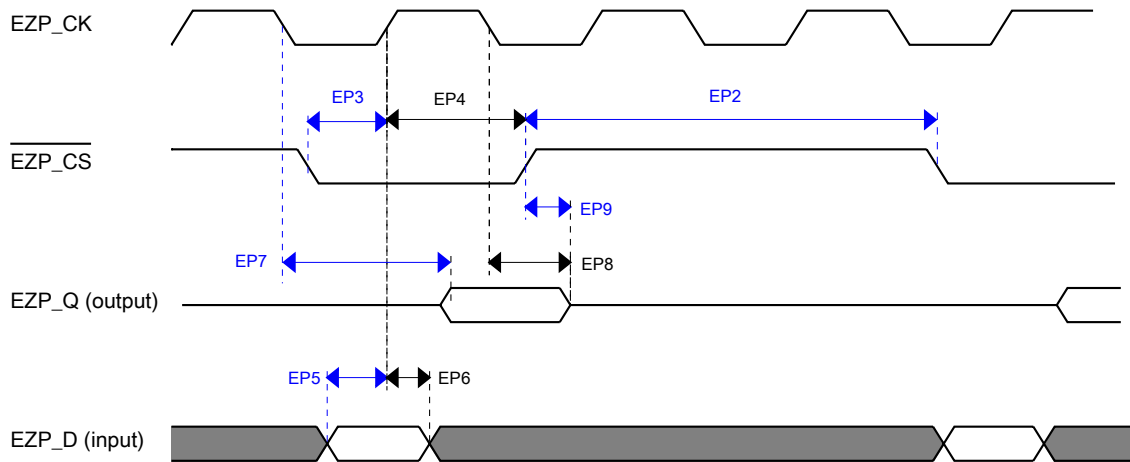

Figure 12. EzPort Timing Diagram

3.4.3 Flexbus switching specifications

All processor bus timings are synchronous; input setup/hold and output delay are given in respect to the rising edge of a reference clock, FB_CLK. The FB_CLK frequency may be the same as the internal system bus frequency or an integer divider of that frequency.

The following timing numbers indicate when data is latched or driven onto the external bus, relative to the Flexbus output clock (FB_CLK). All other timing relationships can be derived from these values.

Table 27. Flexbus limited voltage range switching specifications

Num	Description	Min.	Max.	Unit	Notes
	Operating voltage	2.7	3.6	V	
	Frequency of operation	—	FB_CLK	MHz	
FB1	Clock period	1/FB_CLK	—	ns	
FB2	Address, data, and control output valid	—	11.8	ns	
FB3	Address, data, and control output hold	1.0	—	ns	1
FB4	Data and $\overline{\text{FB_TA}}$ input setup	11.9	—	ns	
FB5	Data and $\overline{\text{FB_TA}}$ input hold	0.0	—	ns	2

1. Specification is valid for all FB_AD[31:0], $\overline{\text{FB_BE/BWE}n}$, $\overline{\text{FB_CS}n}$, $\overline{\text{FB_OE}}$, $\overline{\text{FB_R/W}}$, $\overline{\text{FB_TBST}}$, $\overline{\text{FB_TSIZ}}[1:0]$, $\overline{\text{FB_ALE}}$, and $\overline{\text{FB_TS}}$.

Peripheral operating requirements and behaviors

- Specification is valid for all FB_AD[31:0] and $\overline{\text{FB_TA}}$.

Table 28. Flexbus full voltage range switching specifications

Num	Description	Min.	Max.	Unit	Notes
	Operating voltage	1.71	3.6	V	
	Frequency of operation	—	FB_CLK	MHz	
FB1	Clock period	1/FB_CLK	—	ns	
FB2	Address, data, and control output valid	—	12.6	ns	
FB3	Address, data, and control output hold	1.0	—	ns	1
FB4	Data and $\overline{\text{FB_TA}}$ input setup	12.5	—	ns	
FB5	Data and $\overline{\text{FB_TA}}$ input hold	0	—	ns	2

- Specification is valid for all FB_AD[31:0], $\overline{\text{FB_BE/BWEn}}$, $\overline{\text{FB_CSn}}$, $\overline{\text{FB_OE}}$, FB_R/W, FB_TBST, FB_TSIZ[1:0], FB_ALE, and FB_TS.
- Specification is valid for all FB_AD[31:0] and $\overline{\text{FB_TA}}$.

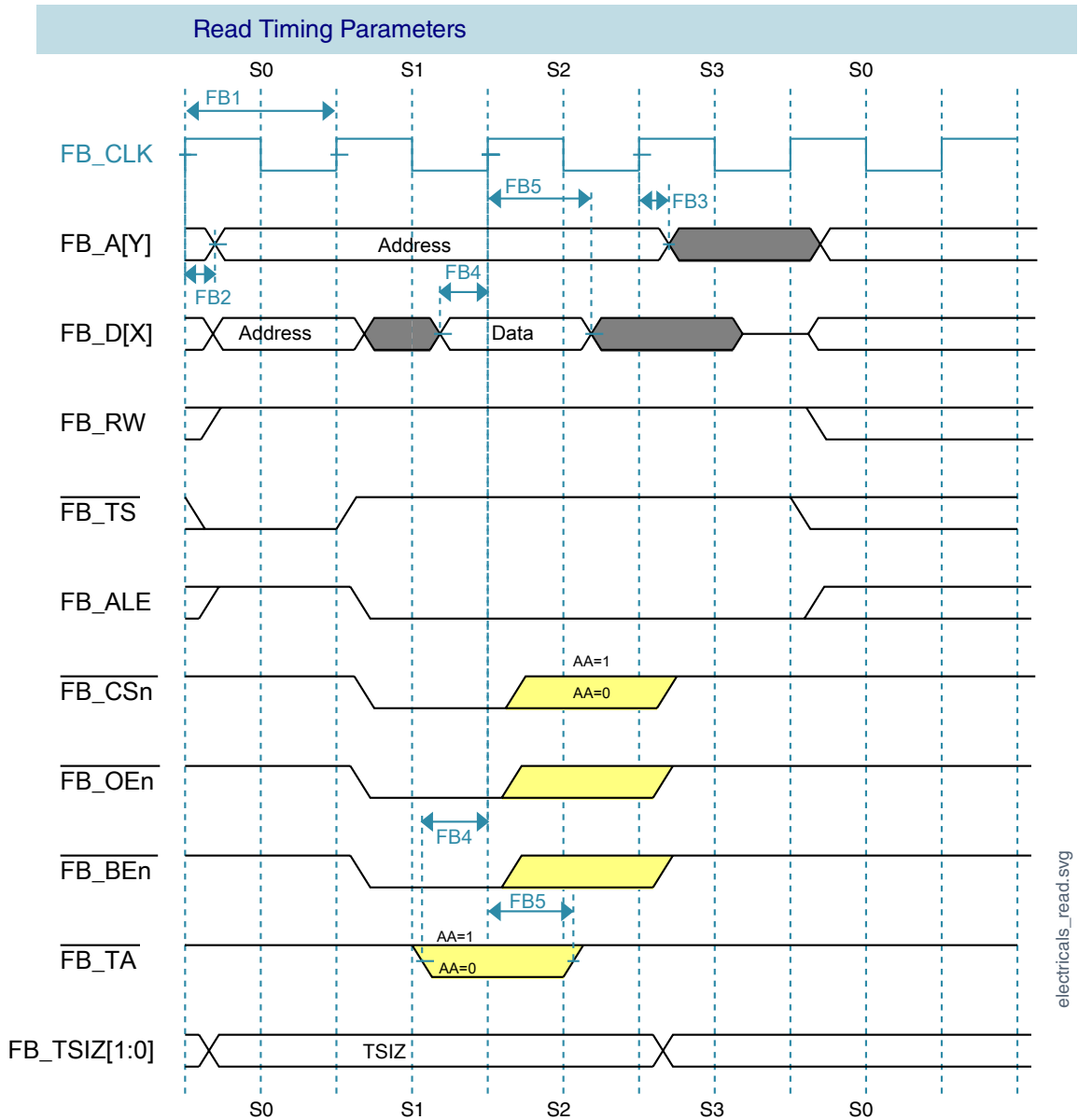

Figure 13. FlexBus read timing diagram

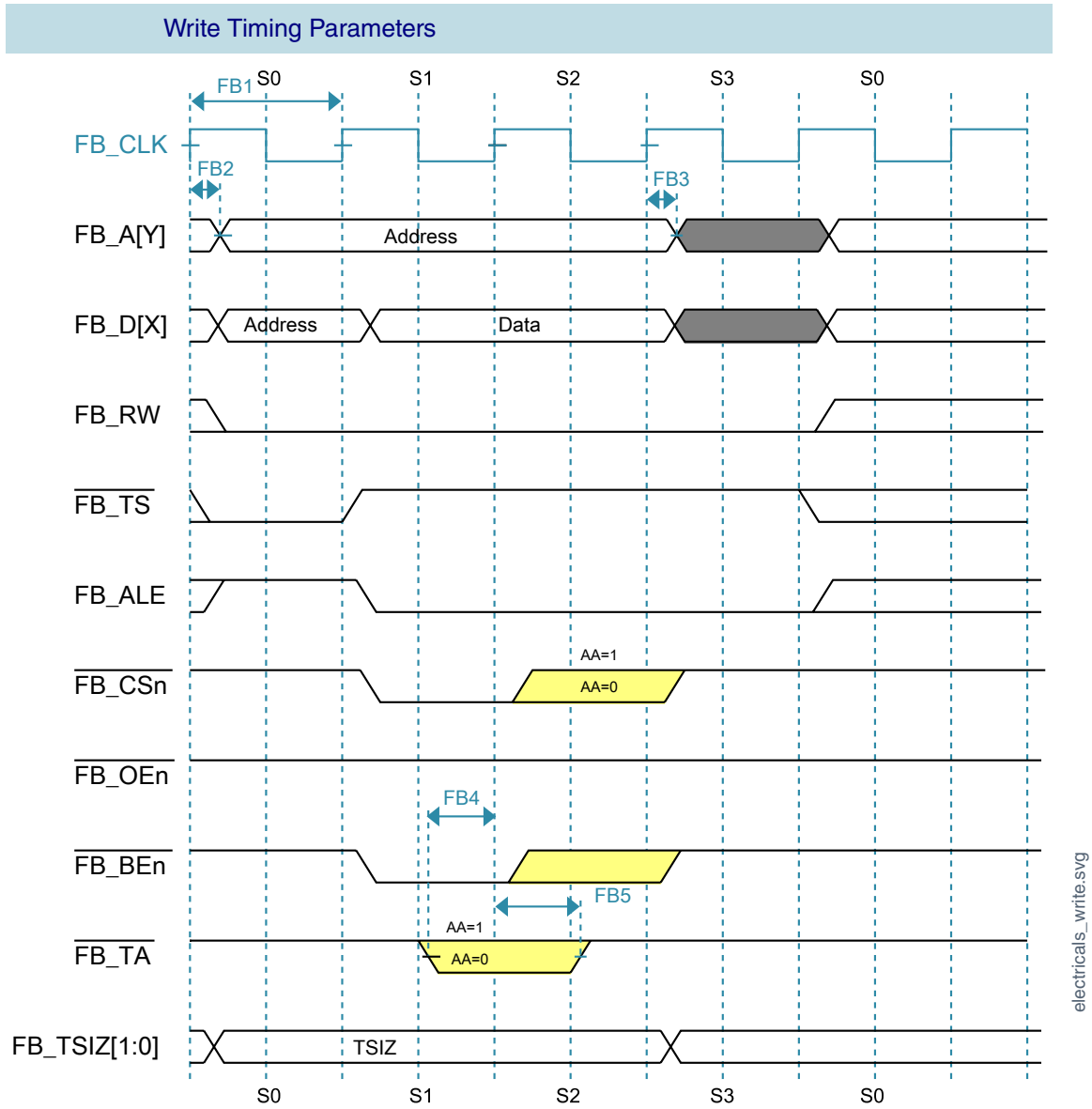
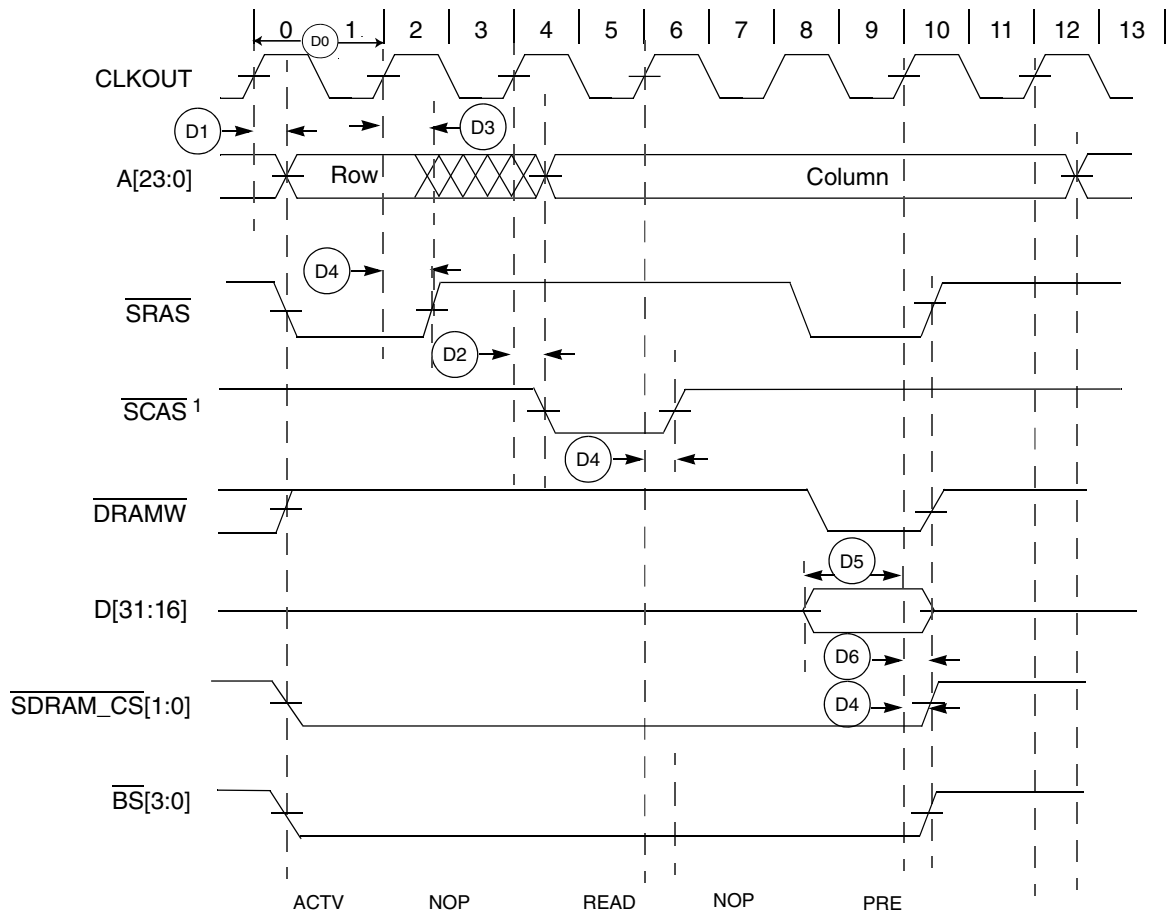

Figure 14. FlexBus write timing diagram

3.4.4 SDRAM controller specifications

Following figure shows SDRAM read cycle.



¹DACR[CASL] = 2

Figure 15. SDRAM read timing diagram

Table 29. SDRAM Timing (Full voltage range)

NUM	Characteristic ¹	Symbol	Min	Max	Unit
	Operating voltage	1.71	3.6	V	
	Frequency of operation	—	CLKOUT	MHz	
D0	Clock period	1/CLKOUT	—	ns	2
D1	CLKOUT high to SDRAM address valid	t_{CHDAV}	-	11.2	ns
D2	CLKOUT high to SDRAM control valid	t_{CHDCV}		11.1	ns
D3	CLKOUT high to SDRAM address invalid	t_{CHDAI}	1.0	-	ns
D4	CLKOUT high to SDRAM control invalid	t_{CHDCI}	1.0	-	ns
D5	SDRAM data valid to CLKOUT high	t_{DDVCH}	12.0	-	ns
D6	CLKOUT high to SDRAM data invalid	t_{CHDDI}	1.0	-	ns
D7 ³	CLKOUT high to SDRAM data valid	t_{CHDDVW}	-	12.0	ns
D8 ³	CLKOUT high to SDRAM data invalid	t_{CHDDIW}	1.0	-	ns

1. All timing specifications are based on taking into account, a 25pF load on the SDRAM output pins.

2. CLKOUT is same as FB_CLK, maximum frequency can be 60 MHz

Peripheral operating requirements and behaviors

- D7 and D8 are for write cycles only.

Table 30. SDRAM Timing (Limited voltage range)

NUM	Characteristic ¹	Symbol	Min	Max	Unit
	Operating voltage	2.7	3.6	V	
	Frequency of operation	—	CLKOUT	MHz	
D0	Clock period	1/CLKOUT	—	ns	2
D1	CLKOUT high to SDRAM address valid	t _{CHDAV}	-	11.1	ns
D2	CLKOUT high to SDRAM control valid	t _{CHDCV}		11.1	ns
D3	CLKOUT high to SDRAM address invalid	t _{CHDAI}	1.0	-	ns
D4	CLKOUT high to SDRAM control invalid	t _{CHDCI}	1.0	-	ns
D5	SDRAM data valid to CLKOUT high	t _{DDVCH}	11.3	-	ns
D6	CLKOUT high to SDRAM data invalid	t _{CHDDI}	1.0	-	ns
D7 ³	CLKOUT high to SDRAM data valid	t _{CHDDVW}	-	11.1	ns
D8 ³	CLKOUT high to SDRAM data invalid	t _{CHDDIW}	1.0	-	ns

- All timing specifications are based on taking into account, a 25pF load on the SDRAM output pins.
- CLKOUT is same as FB_CLK, maximum frequency can be 60 MHz
- D7 and D8 are for write cycles only.

Following figure shows an SDRAM write cycle.

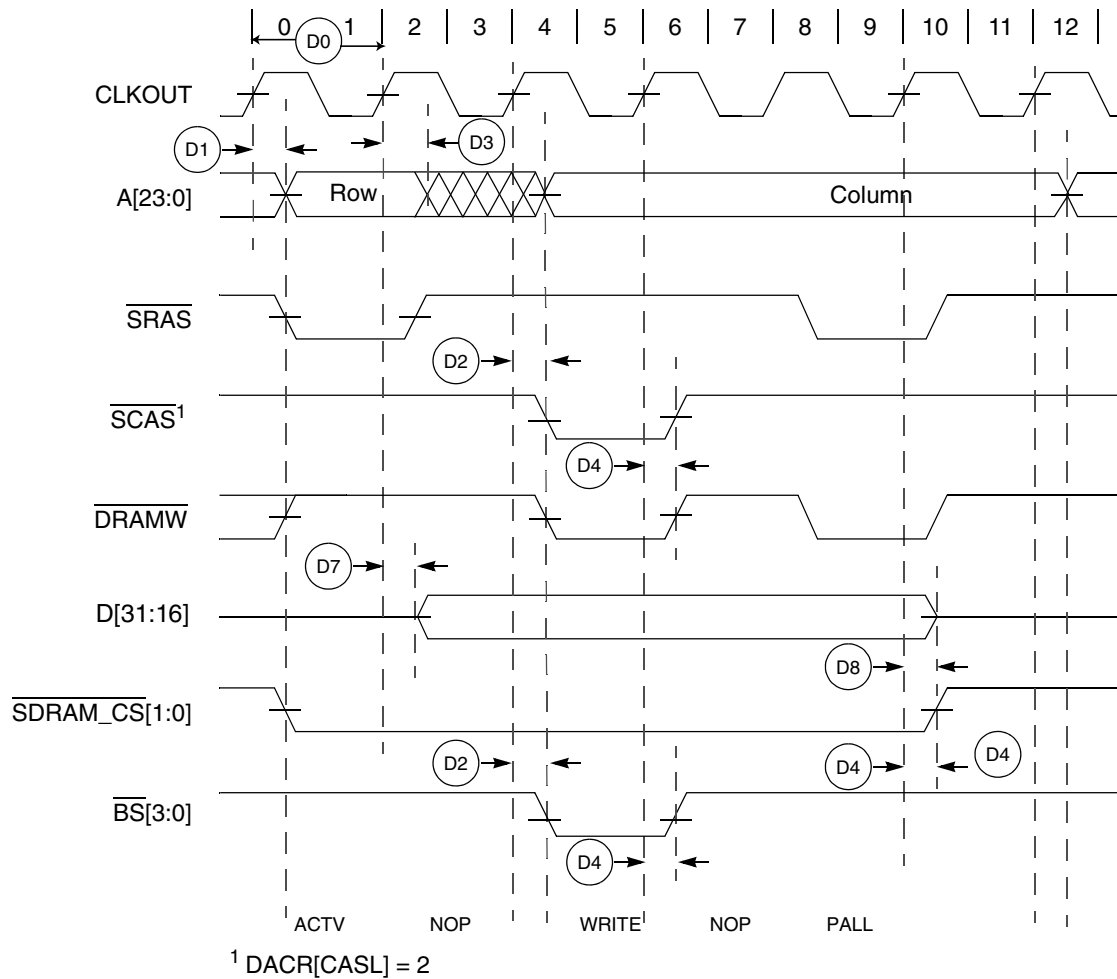

Figure 16. SDRAM write timing diagram

3.5 Security and integrity modules

There are no specifications necessary for the device's security and integrity modules.

3.6 Analog

3.6.1 ADC electrical specifications

The 16-bit accuracy specifications listed in [Table 31](#) and [Table 32](#) are achievable on the differential pins ADCx_DP0, ADCx_DM0.

All other ADC channels meet the 13-bit differential/12-bit single-ended accuracy specifications.

3.6.1.1 16-bit ADC operating conditions

Table 31. 16-bit ADC operating conditions

Symbol	Description	Conditions	Min.	Typ. ¹	Max.	Unit	Notes
V _{DDA}	Supply voltage	Absolute	1.71	—	3.6	V	—
ΔV _{DDA}	Supply voltage	Delta to V _{DD} (V _{DD} – V _{DDA})	-100	0	+100	mV	2
ΔV _{SSA}	Ground voltage	Delta to V _{SS} (V _{SS} – V _{SSA})	-100	0	+100	mV	2
V _{REFH}	ADC reference voltage high		1.13	V _{DDA}	V _{DDA}	V	
V _{REFL}	ADC reference voltage low		V _{SSA}	V _{SSA}	V _{SSA}	V	
V _{ADIN}	Input voltage	<ul style="list-style-type: none"> 16-bit differential mode All other modes 	V _{REFL} V _{REFL}	— —	31/32 * V _{REFH} V _{REFH}	V	—
C _{ADIN}	Input capacitance	<ul style="list-style-type: none"> 16-bit mode 8-bit / 10-bit / 12-bit modes 	— —	8 4	10 5	pF	—
R _{ADIN}	Input series resistance		—	2	5	kΩ	—
R _{AS}	Analog source resistance (external)	13-bit / 12-bit modes f _{ADCK} < 4 MHz	—	—	5	kΩ	3
f _{ADCK}	ADC conversion clock frequency	≤ 13-bit mode	1.0	—	24	MHz	4
f _{ADCK}	ADC conversion clock frequency	16-bit mode	2.0	—	12.0	MHz	4
C _{rate}	ADC conversion rate	≤ 13-bit modes No ADC hardware averaging Continuous conversions enabled, subsequent conversion time	20.000	—	1200	kS/s	5
C _{rate}	ADC conversion rate	16-bit mode No ADC hardware averaging Continuous conversions enabled, subsequent conversion time	37.037	—	461.467	kS/s	5

1. Typical values assume V_{DDA} = 3.0 V, Temp = 25 °C, f_{ADCK} = 1.0 MHz, unless otherwise stated. Typical values are for reference only, and are not tested in production.
2. DC potential difference.
3. This resistance is external to MCU. To achieve the best results, the analog source resistance must be kept as low as possible. The results in this data sheet were derived from a system that had < 8 Ω analog source resistance. The R_{AS}/C_{AS} time constant should be kept to < 1 ns.

4. To use the maximum ADC conversion clock frequency, CFG2[ADHSC] must be set and CFG1[ADLPC] must be clear.
5. For guidelines and examples of conversion rate calculation, download the [ADC calculator tool](#).

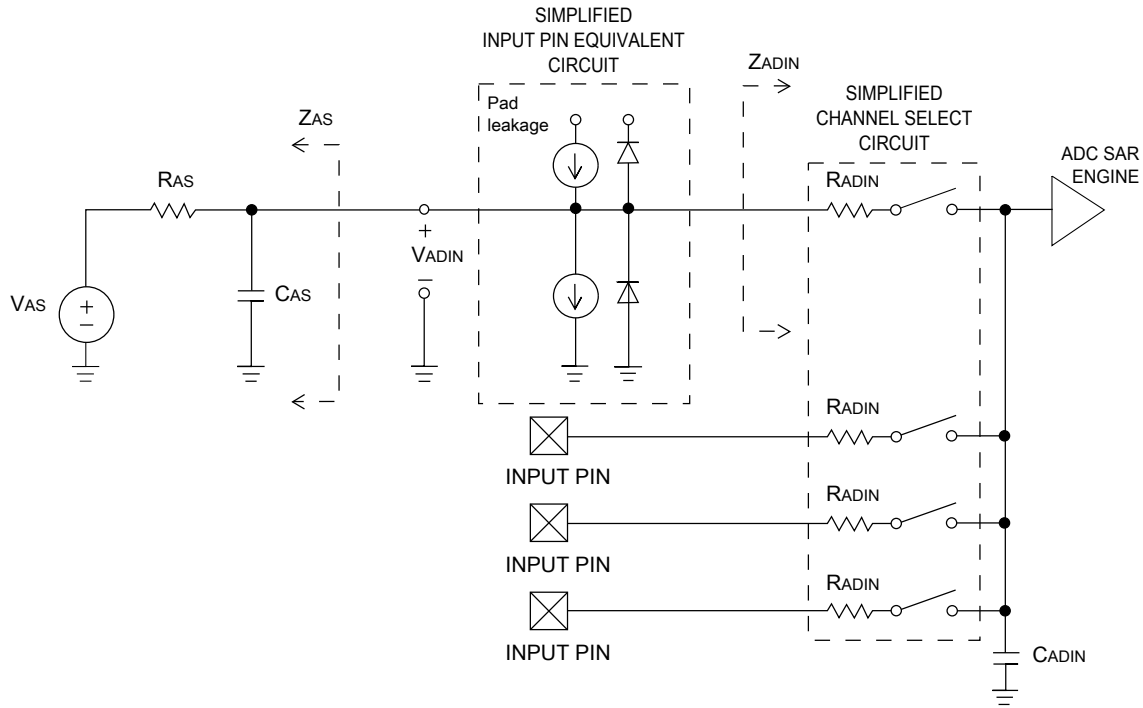

Figure 17. ADC input impedance equivalency diagram

3.6.1.2 16-bit ADC electrical characteristics

Table 32. 16-bit ADC characteristics ($V_{REFH} = V_{DDA}$, $V_{REFL} = V_{SSA}$)

Symbol	Description	Conditions ¹	Min.	Typ. ²	Max.	Unit	Notes
I_{DDA_ADC}	Supply current		0.215	—	1.7	mA	3
f_{ADACK}	ADC asynchronous clock source	• ADLPC = 1, ADHSC = 0	1.2	2.4	3.9	MHz	$t_{ADACK} = 1/f_{ADACK}$
		• ADLPC = 1, ADHSC = 1	2.4	4.0	6.1	MHz	
		• ADLPC = 0, ADHSC = 0	3.0	5.2	7.3	MHz	
		• ADLPC = 0, ADHSC = 1	4.4	6.2	9.5	MHz	
	Sample Time	See Reference Manual chapter for sample times					
TUE	Total unadjusted error	• 12-bit modes • <12-bit modes	—	±4 ±1.4	±6.8 ±2.1	LSB ⁴	5
DNL	Differential non-linearity	• 12-bit modes • <12-bit modes	—	±0.7 ±0.2	-1.1 to +1.9 -0.3 to 0.5	LSB ⁴	5

Table continues on the next page...

Table 32. 16-bit ADC characteristics ($V_{REFH} = V_{DDA}$, $V_{REFL} = V_{SSA}$) (continued)

Symbol	Description	Conditions ¹	Min.	Typ. ²	Max.	Unit	Notes
INL	Integral non-linearity	<ul style="list-style-type: none"> 12-bit modes <12-bit modes 	—	±1.0	-2.7 to +1.9	LSB ⁴	5
E _{FS}	Full-scale error	<ul style="list-style-type: none"> 12-bit modes <12-bit modes 	—	-4	-5.4	LSB ⁴	V _{ADIN} = V _{DDA} ⁵
E _Q	Quantization error	<ul style="list-style-type: none"> 16-bit modes ≤13-bit modes 	—	-1 to 0	—	LSB ⁴	
ENOB	Effective number of bits	16-bit differential mode <ul style="list-style-type: none"> Avg = 32 Avg = 4 16-bit single-ended mode <ul style="list-style-type: none"> Avg = 32 Avg = 4 	12.8 11.9	14.5 13.8	— —	bits bits	6
SINAD	Signal-to-noise plus distortion	See ENOB	6.02 × ENOB + 1.76			dB	
THD	Total harmonic distortion	16-bit differential mode <ul style="list-style-type: none"> Avg = 32 16-bit single-ended mode <ul style="list-style-type: none"> Avg = 32 	—	-94	—	dB dB	7
SFDR	Spurious free dynamic range	16-bit differential mode <ul style="list-style-type: none"> Avg = 32 16-bit single-ended mode <ul style="list-style-type: none"> Avg = 32 	82	95	—	dB dB	7
E _{IL}	Input leakage error		I _{in} × R _{AS}			mV	I _{in} = leakage current (refer to the MCU's voltage and current operating ratings)
	Temp sensor slope	Across the full temperature range of the device	1.55	1.62	1.69	mV/°C	8
V _{TEMP25}	Temp sensor voltage	25 °C	706	716	726	mV	8

1. All accuracy numbers assume the ADC is calibrated with $V_{REFH} = V_{DDA}$

2. Typical values assume $V_{DDA} = 3.0\text{ V}$, $\text{Temp} = 25\text{ }^\circ\text{C}$, $f_{\text{ADCK}} = 2.0\text{ MHz}$ unless otherwise stated. Typical values are for reference only and are not tested in production.
3. The ADC supply current depends on the ADC conversion clock speed, conversion rate and `ADC_CFG1[ADLPC]` (low power). For lowest power operation, `ADC_CFG1[ADLPC]` must be set, the `ADC_CFG2[ADHSC]` bit must be clear with 1 MHz ADC conversion clock speed.
4. $1\text{ LSB} = (V_{\text{REFH}} - V_{\text{REFL}})/2^N$
5. ADC conversion clock < 16 MHz, Max hardware averaging (`AVGE = %1`, `AVGS = %11`)
6. Input data is 100 Hz sine wave. ADC conversion clock < 12 MHz.
7. Input data is 1 kHz sine wave. ADC conversion clock < 12 MHz.
8. ADC conversion clock < 3 MHz

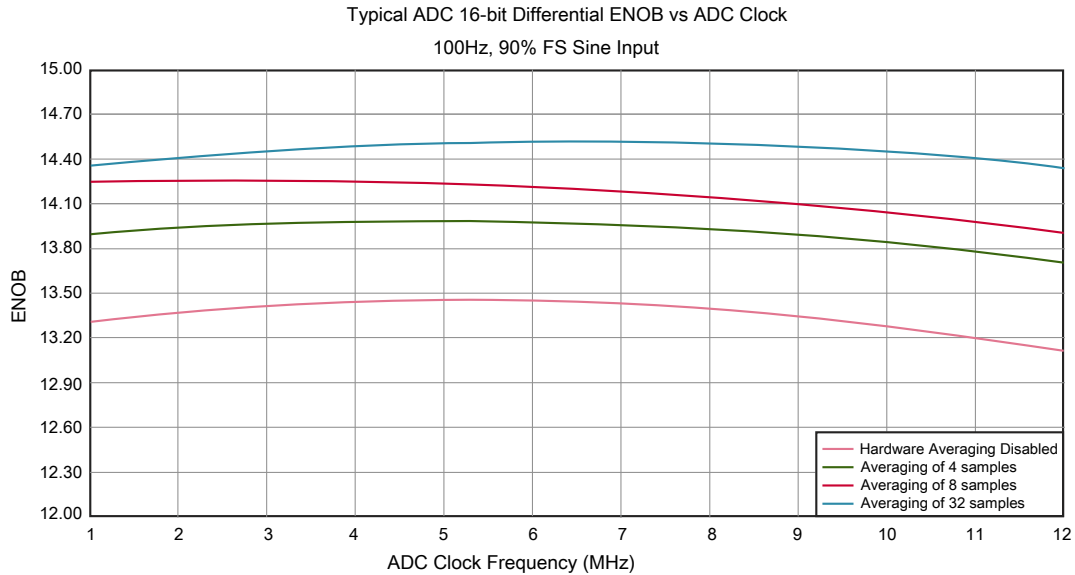

Figure 18. Typical ENOB vs. ADC_CLK for 16-bit differential mode

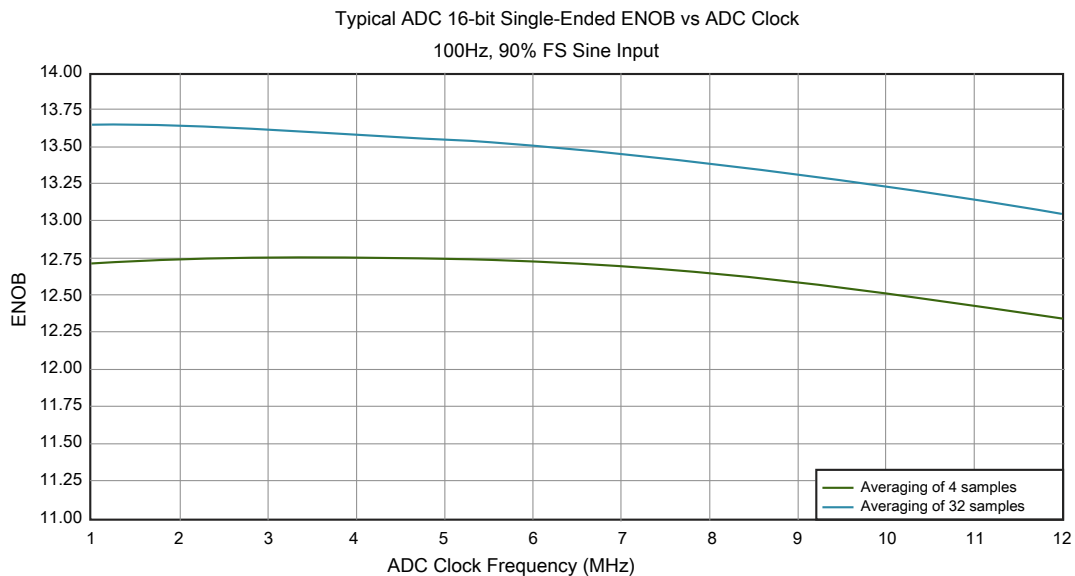

Figure 19. Typical ENOB vs. ADC_CLK for 16-bit single-ended mode

3.6.2 CMP and 6-bit DAC electrical specifications

Table 33. Comparator and 6-bit DAC electrical specifications

Symbol	Description	Min.	Typ.	Max.	Unit
V_{DD}	Supply voltage	1.71	—	3.6	V
I_{DDHS}	Supply current, High-speed mode (EN=1, PMODE=1)	—	—	200	μ A
$I_{DDL S}$	Supply current, low-speed mode (EN=1, PMODE=0)	—	—	20	μ A
V_{AIN}	Analog input voltage	$V_{SS} - 0.3$	—	V_{DD}	V
V_{AIO}	Analog input offset voltage	—	—	20	mV
V_H	Analog comparator hysteresis ¹ <ul style="list-style-type: none"> • CR0[HYSTCTR] = 00 • CR0[HYSTCTR] = 01 • CR0[HYSTCTR] = 10 • CR0[HYSTCTR] = 11 	—	5 10 20 30	—	mV mV mV mV
V_{CMPOh}	Output high	$V_{DD} - 0.5$	—	—	V
V_{CMPOl}	Output low	—	—	0.5	V
t_{DHS}	Propagation delay, high-speed mode (EN=1, PMODE=1)	20	50	200	ns
t_{DLS}	Propagation delay, low-speed mode (EN=1, PMODE=0)	80	250	600	ns
	Analog comparator initialization delay ²	—	—	40	μ s
I_{DAC6b}	6-bit DAC current adder (enabled)	—	7	—	μ A
INL	6-bit DAC integral non-linearity	-0.5	—	0.5	LSB ³
DNL	6-bit DAC differential non-linearity	-0.3	—	0.3	LSB

1. Typical hysteresis is measured with input voltage range limited to 0.6 to $V_{DD}-0.6$ V.
2. Comparator initialization delay is defined as the time between software writes to change control inputs (Writes to CMP_DACCR[DACEN], CMP_DACCR[VRSEL], CMP_DACCR[VOSEL], CMP_MUXCR[PSEL], and CMP_MUXCR[MSEL]) and the comparator output settling to a stable level.
3. 1 LSB = $V_{reference}/64$

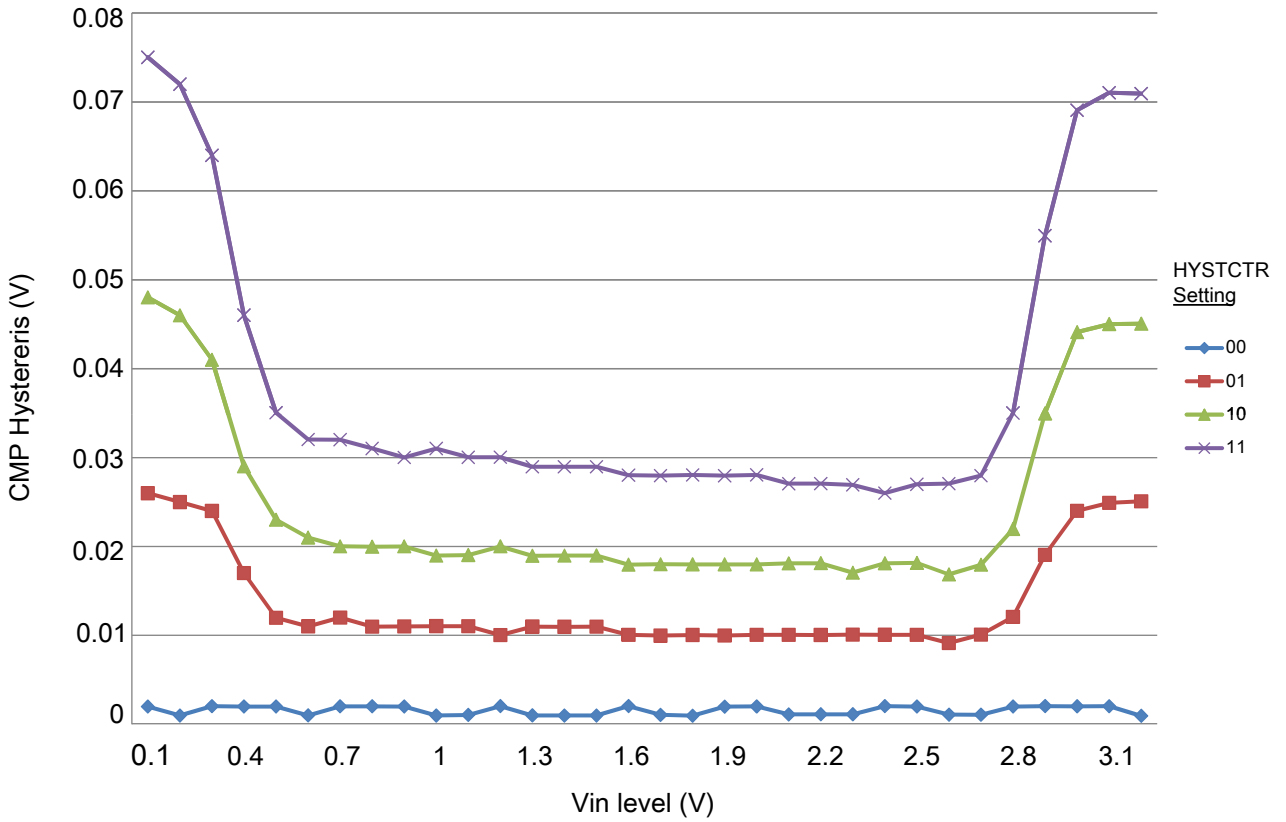

Figure 20. Typical hysteresis vs. Vin level (VDD = 3.3 V, PMODE = 0)

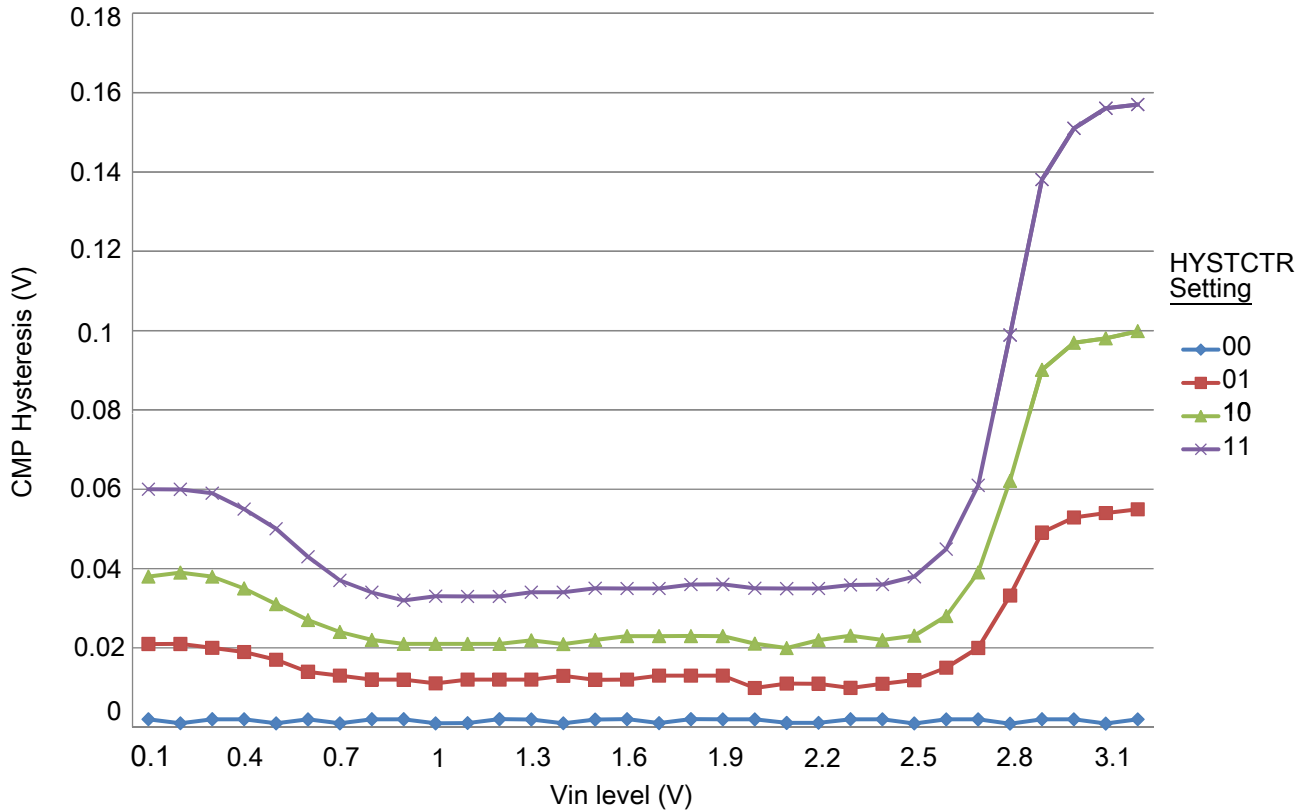

Figure 21. Typical hysteresis vs. Vin level (VDD = 3.3 V, PMODE = 1)

3.6.3 12-bit DAC electrical characteristics

3.6.3.1 12-bit DAC operating requirements

Table 34. 12-bit DAC operating requirements

Symbol	Description	Min.	Max.	Unit	Notes
V_{DDA}	Supply voltage		3.6	V	
V_{DACR}	Reference voltage	1.13	3.6	V	1
C_L	Output load capacitance	—	100	pF	2
I_L	Output load current	—	1	mA	

1. The DAC reference can be selected to be V_{DDA} or V_{REFH} .
2. A small load capacitance (47 pF) can improve the bandwidth performance of the DAC.

3.6.3.2 12-bit DAC operating behaviors

Table 35. 12-bit DAC operating behaviors

Symbol	Description	Min.	Typ.	Max.	Unit	Notes
I_{DDA_DACLP}	Supply current — low-power mode	—	—	150	μA	
I_{DDA_DACHP}	Supply current — high-speed mode	—	—	700	μA	
t_{DACLP}	Full-scale settling time (0x080 to 0xF7F) — low-power mode	—	100	200	μs	1
t_{DACHP}	Full-scale settling time (0x080 to 0xF7F) — high-power mode	—	15	30	μs	1
$t_{CCDACLP}$	Code-to-code settling time (0xBF8 to 0xC08) — low-power mode and high-speed mode	—	0.7	1	μs	1
$V_{dacoutl}$	DAC output voltage range low — high-speed mode, no load, DAC set to 0x000	—	—	100	mV	
$V_{dacouth}$	DAC output voltage range high — high-speed mode, no load, DAC set to 0xFFFF	$V_{DACR} - 100$	—	V_{DACR}	mV	
INL	Integral non-linearity error — high speed mode	—	—	± 8	LSB	2
DNL	Differential non-linearity error — $V_{DACR} > 2\text{ V}$	—	—	± 1	LSB	3
DNL	Differential non-linearity error — $V_{DACR} = V_{REF_OUT}$	—	—	± 1	LSB	4
V_{OFFSET}	Offset error	—	± 0.4	± 0.8	%FSR	5
E_G	Gain error	—	± 0.1	± 0.6	%FSR	5
PSRR	Power supply rejection ratio, $V_{DDA} \geq 2.4\text{ V}$	60	—	90	dB	
T_{CO}	Temperature coefficient offset voltage	—	3.7	—	$\mu\text{V}/\text{C}$	6
T_{GE}	Temperature coefficient gain error	—	0.000421	—	%FSR/C	
A_C	Offset aging coefficient	—	—	100	$\mu\text{V}/\text{yr}$	
R_{op}	Output resistance (load = 3 k Ω)	—	—	250	Ω	
SR	Slew rate -80h → F7Fh → 80h <ul style="list-style-type: none"> High power (SP_{HP}) Low power (SP_{LP}) 	1.2 0.05	1.7 0.12	— —	V/ μs	
CT	Channel to channel cross talk	—	—	-80	dB	
BW	3dB bandwidth <ul style="list-style-type: none"> High power (SP_{HP}) Low power (SP_{LP}) 	550 40	— —	— —	kHz	

1. Settling within ± 1 LSB
2. The INL is measured for 0 + 100 mV to $V_{DACR} - 100\text{ mV}$
3. The DNL is measured for 0 + 100 mV to $V_{DACR} - 100\text{ mV}$
4. The DNL is measured for 0 + 100 mV to $V_{DACR} - 100\text{ mV}$ with $V_{DDA} > 2.4\text{ V}$
5. Calculated by a best fit curve from $V_{SS} + 100\text{ mV}$ to $V_{DACR} - 100\text{ mV}$

Peripheral operating requirements and behaviors

- 6. $V_{DDA} = 3.0\text{ V}$, reference select set for V_{DDA} ($\text{DACx_CO:DACRFS} = 1$), high power mode ($\text{DACx_CO:LPEN} = 0$), DAC set to 0x800, temperature range is across the full range of the device

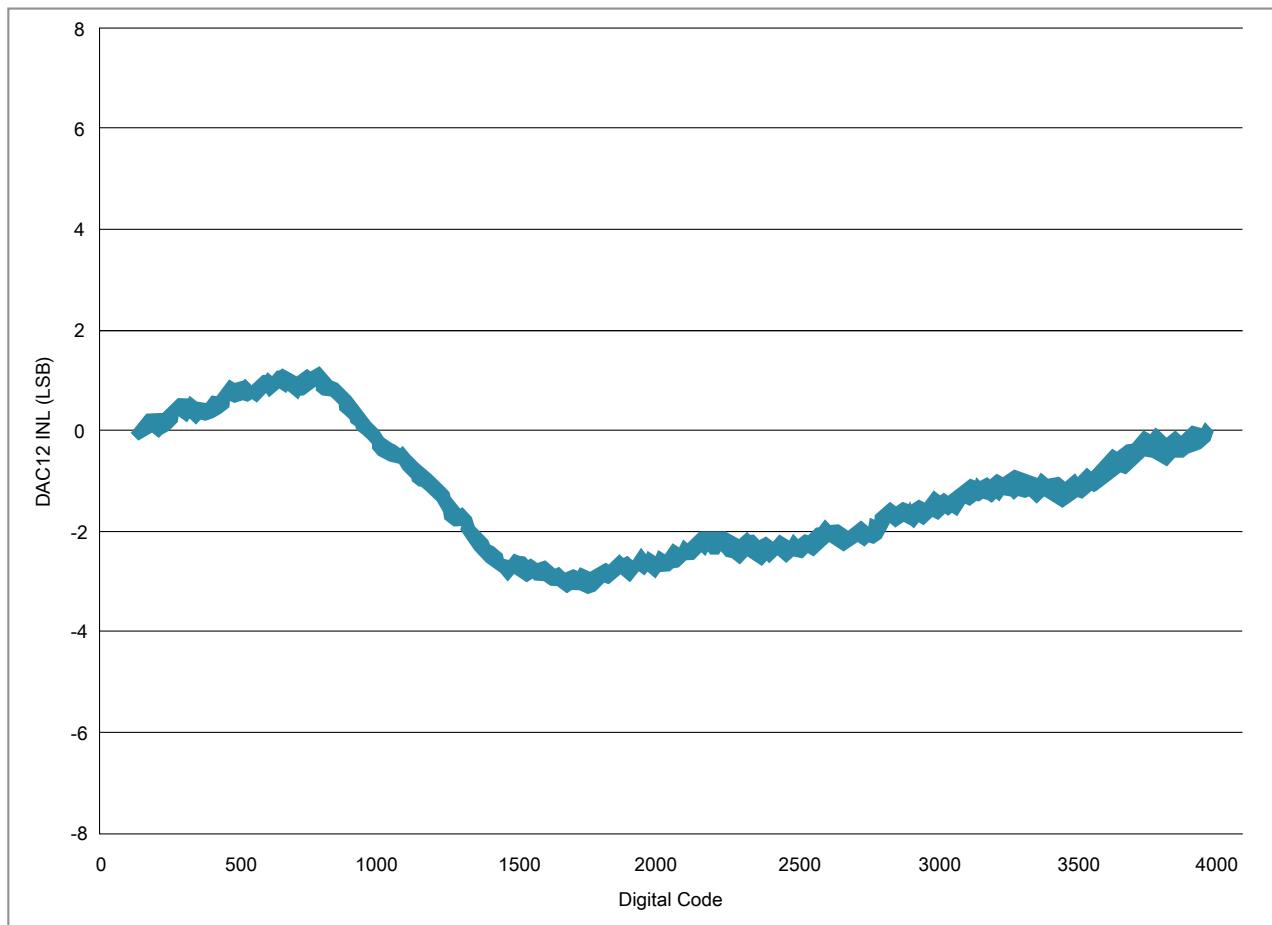

Figure 22. Typical INL error vs. digital code

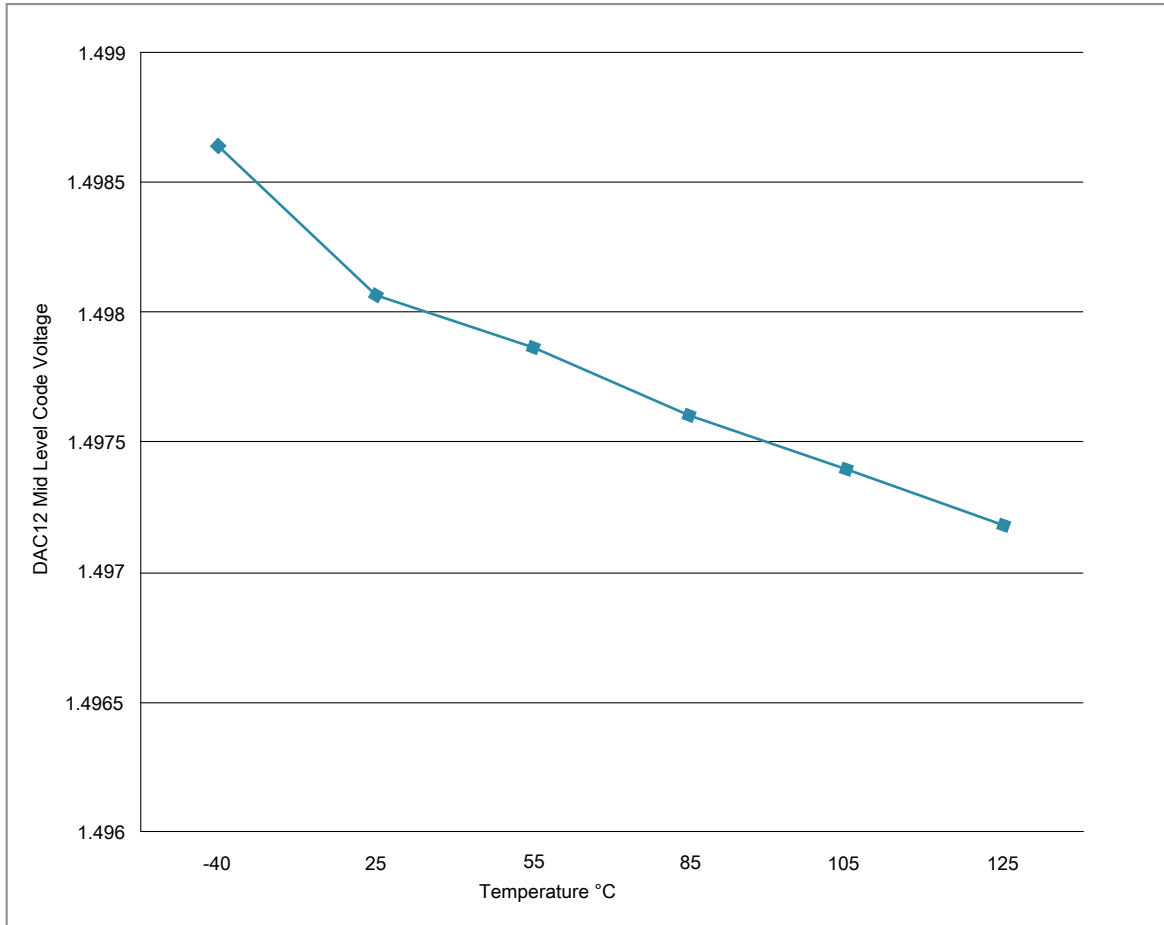

Figure 23. Offset at half scale vs. temperature

3.6.4 Voltage reference electrical specifications

Table 36. VREF full-range operating requirements

Symbol	Description	Min.	Max.	Unit	Notes
V_{DDA}	Supply voltage		3.6	V	
T_A	Temperature	Operating temperature range of the device		°C	
C_L	Output load capacitance	100		nF	1, 2

1. C_L must be connected to VREF_OUT if the VREF_OUT functionality is being used for either an internal or external reference.
2. The load capacitance should not exceed +/-25% of the nominal specified C_L value over the operating temperature range of the device.

Table 37. VREF full-range operating behaviors

Symbol	Description	Min.	Typ.	Max.	Unit	Notes
V _{out}	Voltage reference output with factory trim at nominal V _{DDA} and temperature=25C	1.190	1.195	1.200	V	1
V _{out}	Voltage reference output — factory trim	1.1584	—	1.2376	V	1
V _{out}	Voltage reference output — user trim	1.193	—	1.197	V	1
V _{step}	Voltage reference trim step	—	0.5	—	mV	1
V _{tdrift}	Temperature drift (V _{max} -V _{min} across the full temperature range)	—	—	80	mV	1
Ac	Aging coefficient	—	—	400	uV/yr	—
I _{bg}	Bandgap only current	—	—	80	μA	1
ΔV _{LOAD}	Load regulation • current = ± 1.0 mA	—	200	—	μV	1, 2
T _{stup}	Buffer startup time	—	—	100	μs	—
T _{chop_osc_st up}	Internal bandgap start-up delay with chop oscillator enabled	—	—	35	ms	—
V _{vdrift}	Voltage drift (V _{max} -V _{min} across the full voltage range)	—	2	—	mV	1

1. See the chip's Reference Manual for the appropriate settings of the VREF Status and Control register.
2. Load regulation voltage is the difference between the VREF_OUT voltage with no load vs. voltage with defined load

Table 38. VREF limited-range operating requirements

Symbol	Description	Min.	Max.	Unit	Notes
T _A	Temperature	0	50	°C	

Table 39. VREF limited-range operating behaviors

Symbol	Description	Min.	Max.	Unit	Notes
V _{out}	Voltage reference output with factory trim	1.173	1.225	V	

3.7 Timers

See [General switching specifications](#).

3.8 Communication interfaces

3.8.1 Ethernet switching specifications

The following timing specs are defined at the chip I/O pin and must be translated appropriately to arrive at timing specs/constraints for the physical interface.

3.8.1.1 MII signal switching specifications

The following timing specs meet the requirements for MII style interfaces for a range of transceiver devices.

Table 40. MII signal switching specifications (limited voltage range)

Symbol	Description	Min.	Max.	Unit
—	Operating Voltage	2.7	3.6	V
—	RXCLK frequency	—	25	MHz
MII1	RXCLK pulse width high	35%	65%	RXCLK period
MII2	RXCLK pulse width low	35%	65%	RXCLK period
MII3	RXD[3:0], RXDV, RXER to RXCLK setup	5	—	ns
MII4	RXCLK to RXD[3:0], RXDV, RXER hold	5	—	ns
—	TXCLK frequency	—	25	MHz
MII5	TXCLK pulse width high	35%	65%	TXCLK period
MII6	TXCLK pulse width low	35%	65%	TXCLK period
MII7	TXCLK to TXD[3:0], TXEN, TXER invalid	2	—	ns
MII8	TXCLK to TXD[3:0], TXEN, TXER valid	—	25	ns

Table 41. MII signal switching specifications (full voltage range)

Symbol	Description	Min.	Max.	Unit
—	Operating Voltage	1.7	3.6	V
—	RXCLK frequency	—	25	MHz
MII1	RXCLK pulse width high	35%	65%	RXCLK period
MII2	RXCLK pulse width low	35%	65%	RXCLK period
MII3	RXD[3:0], RXDV, RXER to RXCLK setup	5	—	ns

Table continues on the next page...

**Table 41. MII signal switching specifications (full voltage range)
(continued)**

Symbol	Description	Min.	Max.	Unit
MII4	RXCLK to RXD[3:0], RXDV, RXER hold	5	—	ns
—	TXCLK frequency	—	25	MHz
MII5	TXCLK pulse width high	35%	65%	TXCLK period
MII6	TXCLK pulse width low	35%	65%	TXCLK period
MII7	TXCLK to TXD[3:0], TXEN, TXER invalid	2	—	ns
MII8	TXCLK to TXD[3:0], TXEN, TXER valid	—	25	ns

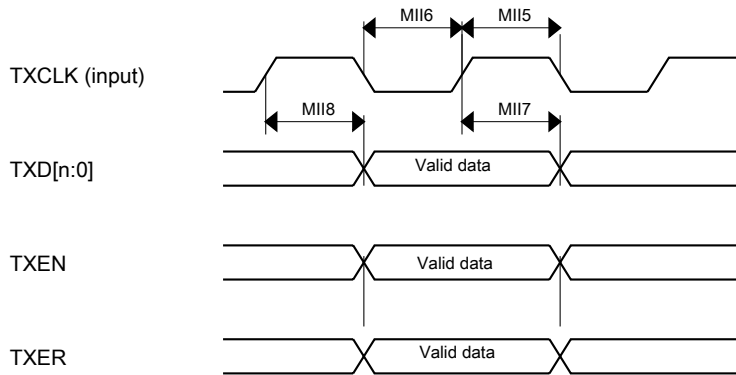

Figure 24. RMII/MII transmit signal timing diagram

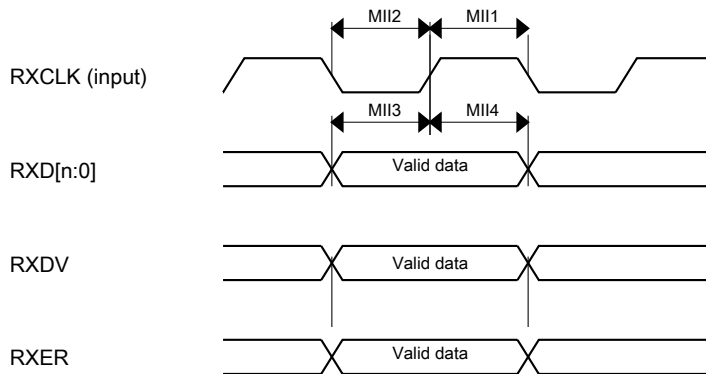

Figure 25. RMII/MII receive signal timing diagram

3.8.1.2 RMI signal switching specifications

The following timing specs meet the requirements for RMI style interfaces for a range of transceiver devices.

Table 42. RMI signal switching specifications (limited voltage range)

Num	Description	Min.	Max.	Unit
—	Operating Voltage	2.7	3.6	
—	EXTAL frequency (RMI input clock RMI_CLK)	—	50	MHz
RMI1	RMI_CLK pulse width high	35%	65%	RMI_CLK period
RMI2	RMI_CLK pulse width low	35%	65%	RMI_CLK period
RMI3	RXD[1:0], CRS_DV, RXER to RMI_CLK setup	4	—	ns
RMI4	RMI_CLK to RXD[1:0], CRS_DV, RXER hold	2	—	ns
RMI7	RMI_CLK to TXD[1:0], TXEN invalid	4	—	ns
RMI8	RMI_CLK to TXD[1:0], TXEN valid	—	15.4	ns

Table 43. RMI signal switching specifications (full voltage range)

Num	Description	Min.	Max.	Unit
—	Operating Voltage	1.7	3.6	
—	EXTAL frequency (RMI input clock RMI_CLK)	—	50	MHz
RMI1	RMI_CLK pulse width high	35%	65%	RMI_CLK period
RMI2	RMI_CLK pulse width low	35%	65%	RMI_CLK period
RMI3	RXD[1:0], CRS_DV, RXER to RMI_CLK setup	4	—	ns
RMI4	RMI_CLK to RXD[1:0], CRS_DV, RXER hold	2	—	ns
RMI7	RMI_CLK to TXD[1:0], TXEN invalid	4	—	ns
RMI8	RMI_CLK to TXD[1:0], TXEN valid	—	17.5	ns

3.8.1.3 MDIO serial management timing specifications

Table 44. MDIO serial management channel signal timing

Num	Characteristic	Symbol	Min	Max	Unit
E10	MDC cycle time	t_{MDC}	400	—	ns
E11	MDC pulse width		40	60	% t_{MDC}
E12	MDC to MDIO output valid		—	375	ns
E13	MDC to MDIO output invalid		25	—	ns
E14	MDIO input to MDC setup		10	—	ns
E15	MDIO input to MDC hold		0	—	ns

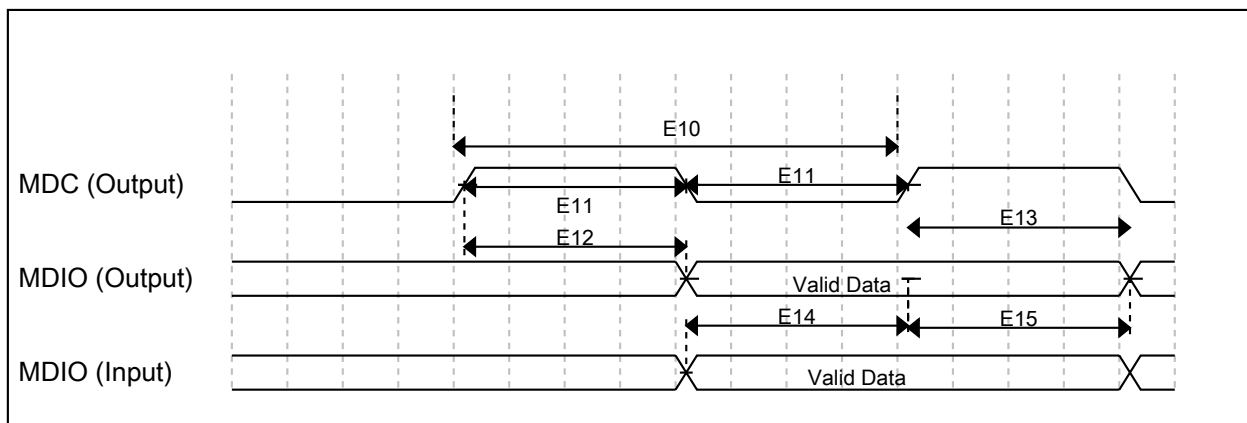

Figure 26. MDIO serial management channel timing diagram

3.8.2 USB Voltage Regulator Electrical Specifications

Table 45. USB VREG electrical specifications

Symbol	Description	Min.	Typ. ¹	Max.	Unit	Notes
VREG_IN0 VREG_IN1	Regulator selectable input supply voltages	2.7	—	5.5	V	2
I _{DDon} VREG_IN0 VREG_IN1	Quiescent current — Run mode, load current equal zero, input supply (VREG_IN*) > 3.6 V	—	157	—	μA	
I _{DDstby} VREG_IN0 VREG_IN1	Quiescent current — Standby mode, load current equal zero	—	2	—	μA	
I _{DDoff} VREG_IN0 VREG_IN1	Quiescent current — Shutdown mode • VREG_IN* = 5.0 V and temperature = 25 °C	—	680 920	—	nA	
I _{LOADrun}	Maximum load current — Run mode	—	—	150	mA	3
I _{LOADstby}	Maximum load current — Standby mode	—	—	1	mA	
V _{DROPOUT}	Regulator drop-out voltage — Run mode at maximum load current with inrush current limit disabled	300	—	—	mV	
VREG_OUT	Regulator programmable output target voltage — Selected input supply > programmed output target voltage + V _{DROPOUT} • Run mode • Standby mode	3 2.1	3.3 2.8	3.6 3.6	V V	4

Table continues on the next page...

**Table 45. USB VREG electrical specifications
(continued)**

Symbol	Description	Min.	Typ. ¹	Max.	Unit	Notes
C _{OUT}	External output capacitor	1.76	2.2	8.16	μF	
ESR	External output capacitor equivalent series resistance	1	—	100	mΩ	
I _{LIM}	Short circuit current	—	350	—	mA	5
I _{INRUSH}	Inrush current limit	40	—	100	mA	6, 7, 8, 9, 10

1. Typical values assume the selected input supply is 5.0 V, Temp = 25 °C unless otherwise stated.
2. Operation range is 2.7 V to 5.5 V; tolerance voltage is up to 6 V.
3. 150mA is inclusive of the run mode current of the on-chip USB modules. Available load outside of the chip depends on USB operation and device power dissipation limits.
4. The target voltage for the regulator is programmable, accounting for the range of the max and min values
5. Current limit disabled.
6. Current limit should be disabled after the powers have stabilized to allow full functionality of the regulator.
7. Limited Characterization
8. I_{INRUSH} with VREG_{INx}=4.0 V to 5.5 V
9. The minimum value of I_{INRUSH} is stated for operation when only one of VREG_IN0 / VREG_IN1 is powered, or when VREG_IN0 and VREG_IN1 both have the same voltage level. When VREG_IN0 and VREG_IN1 are operated at different voltage levels with the selected VREG_IN lower than the non-selected VREG_IN, the minimum value of I_{INRUSH} may decrease to a lower value.
10. Total current load on startup should be less than I_{INRUSH} min over full input voltage range of the regulator.

3.8.3 USB Full Speed Transceiver and High Speed PHY specifications

This section describes the USB0 port Full Speed/Low Speed transceiver and USB1 port USB-PHY High Speed Phy parameters. The high speed phy is capable of full and low speed signalling as well.

The USB0 (FS/LS Transceiver) and USB1 ((USB HS/FS/LS) meet the electrical compliance requirements defined in the Universal Serial Bus Revision 2.0 Specification with the amendments below.

- USB ENGINEERING CHANGE NOTICE
 - Title: 5V Short Circuit Withstand Requirement Change
 - Applies to: Universal Serial Bus Specification, Revision 2.0
- Errata for USB Revision 2.0 April 27, 2000 as of 12/7/2000
- USB ENGINEERING CHANGE NOTICE
 - Title: Pull-up/Pull-down resistors
 - Applies to: Universal Serial Bus Specification, Revision 2.0
- USB ENGINEERING CHANGE NOTICE

Peripheral operating requirements and behaviors

- Title: Suspend Current Limit Changes
- Applies to: Universal Serial Bus Specification, Revision 2.0
- On-The-Go and Embedded Host Supplement to the USB Revision 2.0 Specification
 - Revision 2.0 version 1.1a July 27, 2012
- Battery Charging Specification (available from USB-IF)
 - Revision 1.2 (including errata and ECNs through March 15, 2012), March 15, 2012

USB1_VBUS pin is a detector function which is 5v tolerant and complies with the above specifications without needing any external voltage division components.

3.8.4 USB DCD electrical specifications

Table 46. USB DCD electrical specifications

Symbol	Description	Min.	Typ.	Max.	Unit
V _{DP_SRC} , V _{DM_SRC}	USB_DP and USB_DM source voltages (up to 250 μ A)	0.5	—	0.7	V
V _{LGC}	Threshold voltage for logic high	0.8	—	2.0	V
I _{DP_SRC}	USB_DP source current	7	10	13	μ A
I _{DM_SINK} , I _{DP_SINK}	USB_DM and USB_DP sink currents	50	100	150	μ A
R _{DM_DWN}	D- pulldown resistance for data pin contact detect	14.25	—	24.8	k Ω
V _{DAT_REF}	Data detect voltage	0.25	0.33	0.4	V

3.8.5 CAN switching specifications

See [General switching specifications](#).

3.8.6 DSPI switching specifications (limited voltage range)

The DMA Serial Peripheral Interface (DSPI) provides a synchronous serial bus with master and slave operations. Many of the transfer attributes are programmable. The tables below provide DSPI timing characteristics for classic SPI timing modes. Refer to the DSPI chapter of the Reference Manual for information on the modified transfer formats used for communicating with slower peripheral devices.

Table 47. Master mode DSPI timing (limited voltage range)

Num	Description	Min.	Max.	Unit	Notes
	Operating voltage	2.7	3.6	V	
	Frequency of operation	—	30	MHz	
DS1	DSPI_SCK output cycle time	$2 \times t_{\text{BUS}}$	—	ns	
DS2	DSPI_SCK output high/low time	$(t_{\text{SCK}}/2) - 2$	$(t_{\text{SCK}}/2) + 2$	ns	
DS3	DSPI_PCSn valid to DSPI_SCK delay	$(t_{\text{BUS}} \times 2) - 2$	—	ns	1
DS4	DSPI_SCK to DSPI_PCSn invalid delay	$(t_{\text{BUS}} \times 2) - 2$	—	ns	2
DS5	DSPI_SCK to DSPI_SOUT valid	—	15.0	ns	
DS6	DSPI_SCK to DSPI_SOUT invalid	1.0	—	ns	
DS7	DSPI_SIN to DSPI_SCK input setup	15.8	—	ns	
DS8	DSPI_SCK to DSPI_SIN input hold	0	—	ns	

1. The delay is programmable in SPIx_CTARn[PSSCK] and SPIx_CTARn[CSSCK].
2. The delay is programmable in SPIx_CTARn[PASC] and SPIx_CTARn[ASC].

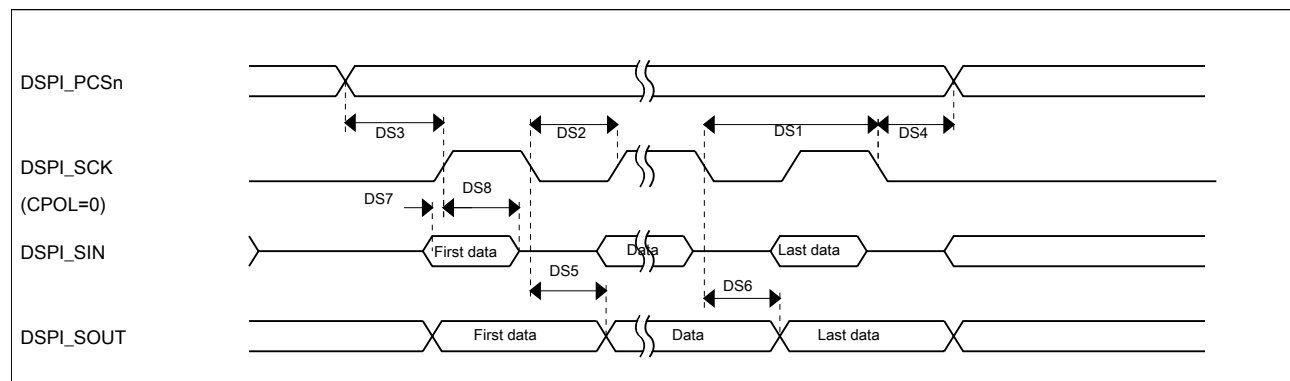

Figure 27. DSPI classic SPI timing — master mode

Table 48. Slave mode DSPI timing (limited voltage range)

Num	Description	Min.	Max.	Unit
	Operating voltage	2.7	3.6	V
	Frequency of operation		15 ¹	MHz

Table continues on the next page...

Table 48. Slave mode DSPI timing (limited voltage range) (continued)

Num	Description	Min.	Max.	Unit
DS9	DSPI_SCK input cycle time	4 x t _{BUS}	—	ns
DS10	DSPI_SCK input high/low time	(t _{SCK} /2) - 2	(t _{SCK} /2) + 2	ns
DS11	DSPI_SCK to DSPI_SOUT valid	—	23.0	ns
DS12	DSPI_SCK to DSPI_SOUT invalid	0	—	ns
DS13	DSPI_SIN to DSPI_SCK input setup	2.7	—	ns
DS14	DSPI_SCK to DSPI_SIN input hold	7.0	—	ns
DS15	DSPI_SS active to DSPI_SOUT driven	—	13	ns
DS16	DSPI_SS inactive to DSPI_SOUT not driven	—	13	ns

- The maximum operating frequency is measured with non-continuous CS and SCK. When DSPI is configured with continuous CS and SCK, there is a constraint that SPI clock should not be greater than 1/6 of bus clock, for example, when bus clock is 60MHz, SPI clock should not be greater than 10MHz.

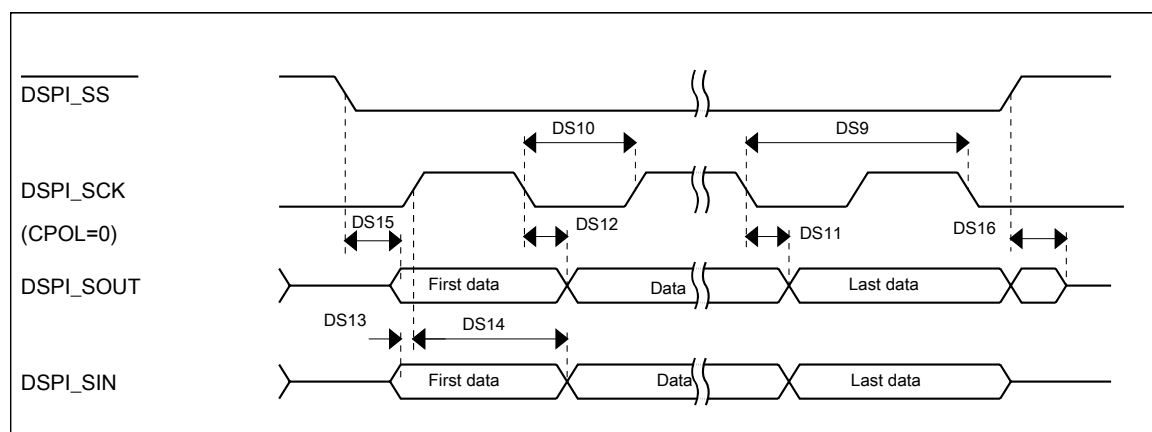

Figure 28. DSPI classic SPI timing — slave mode

3.8.7 DSPI switching specifications (full voltage range)

The DMA Serial Peripheral Interface (DSPI) provides a synchronous serial bus with master and slave operations. Many of the transfer attributes are programmable. The tables below provides DSPI timing characteristics for classic SPI timing modes. Refer to the DSPI chapter of the Reference Manual for information on the modified transfer formats used for communicating with slower peripheral devices.

Table 49. Master mode DSPI timing (full voltage range)

Num	Description	Min.	Max.	Unit	Notes
	Operating voltage	1.71	3.6	V	1
	Frequency of operation	—	15	MHz	

Table continues on the next page...

Table 49. Master mode DSPI timing (full voltage range) (continued)

Num	Description	Min.	Max.	Unit	Notes
DS1	DSPI_SCK output cycle time	$4 \times t_{\text{BUS}}$	—	ns	
DS2	DSPI_SCK output high/low time	$(t_{\text{SCK}/2}) - 4$	$(t_{\text{SCK}/2}) + 4$	ns	
DS3	DSPI_PCS _n valid to DSPI_SCK delay	$(t_{\text{BUS}} \times 2) - 4$	—	ns	2
DS4	DSPI_SCK to DSPI_PCS _n invalid delay	$(t_{\text{BUS}} \times 2) - 4$	—	ns	3
DS5	DSPI_SCK to DSPI_SOUT valid	—	15	ns	
DS6	DSPI_SCK to DSPI_SOUT invalid	1.0	—	ns	
DS7	DSPI_SIN to DSPI_SCK input setup	15.8	—	ns	
DS8	DSPI_SCK to DSPI_SIN input hold	0	—	ns	

1. The DSPI module can operate across the entire operating voltage for the processor, but to run across the full voltage range the maximum frequency of operation is reduced.
2. The delay is programmable in SPIx_CTARn[PSSCK] and SPIx_CTARn[CSSCK].
3. The delay is programmable in SPIx_CTARn[PASC] and SPIx_CTARn[ASC].

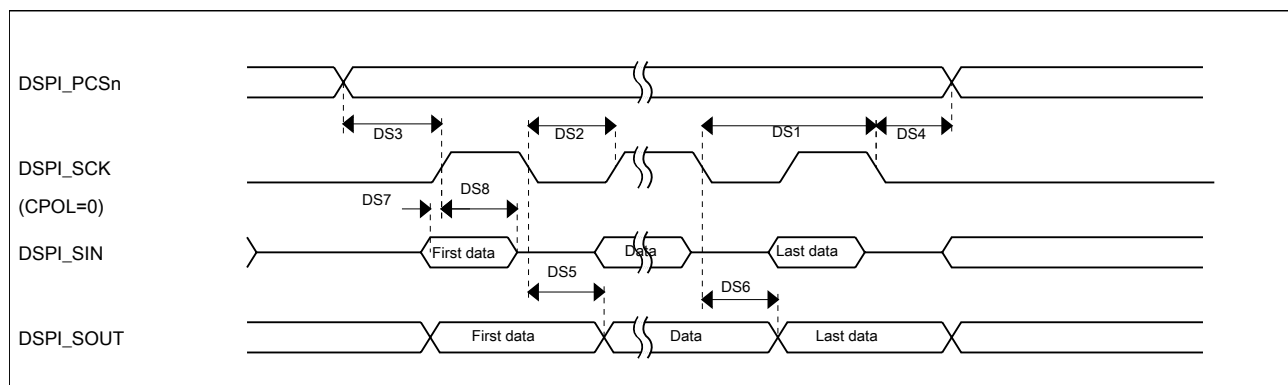
**Figure 29. DSPI classic SPI timing — master mode****Table 50. Slave mode DSPI timing (full voltage range)**

Num	Description	Min.	Max.	Unit
	Operating voltage	1.71	3.6	V
	Frequency of operation	—	7.5	MHz
DS9	DSPI_SCK input cycle time	$8 \times t_{\text{BUS}}$	—	ns
DS10	DSPI_SCK input high/low time	$(t_{\text{SCK}/2}) - 4$	$(t_{\text{SCK}/2}) + 4$	ns
DS11	DSPI_SCK to DSPI_SOUT valid	—	23.1	ns
DS12	DSPI_SCK to DSPI_SOUT invalid	0	—	ns
DS13	DSPI_SIN to DSPI_SCK input setup	2.6	—	ns
DS14	DSPI_SCK to DSPI_SIN input hold	7.0	—	ns
DS15	$\overline{\text{DSPI_SS}}$ active to DSPI_SOUT driven	—	13.0	ns
DS16	$\overline{\text{DSPI_SS}}$ inactive to DSPI_SOUT not driven	—	13.0	ns

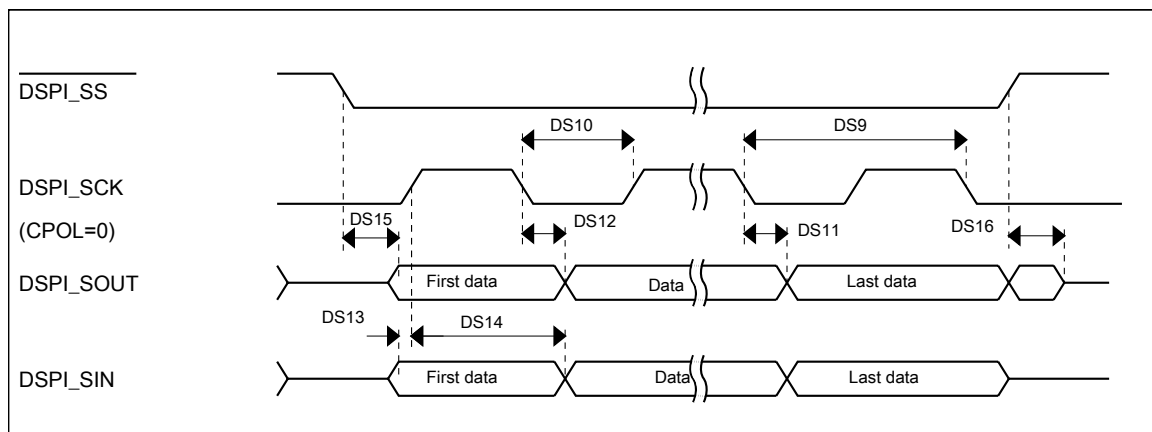

Figure 30. DSPI classic SPI timing — slave mode

3.8.8 Inter-Integrated Circuit Interface (I²C) timing

Table 51. I²C timing

Characteristic	Symbol	Standard Mode		Fast Mode		Unit
		Minimum	Maximum	Minimum	Maximum	
SCL Clock Frequency	f_{SCL}	0	100	0	400	kHz
Hold time (repeated) START condition. After this period, the first clock pulse is generated.	$t_{HD}; STA$	4	—	0.6	—	μs
LOW period of the SCL clock	t_{LOW}	4.7	—	1.25	—	μs
HIGH period of the SCL clock	t_{HIGH}	4	—	0.6	—	μs
Set-up time for a repeated START condition	$t_{SU}; STA$	4.7	—	0.6	—	μs
Data hold time for I ² C bus devices	$t_{HD}; DAT$	0 ¹	3.45 ²	0 ³	0.9 ¹	μs
Data set-up time	$t_{SU}; DAT$	250 ⁴	—	100 ^{2, 5}	—	ns
Rise time of SDA and SCL signals	t_r	—	1000	$20 + 0.1C_b$ ⁶	300	ns
Fall time of SDA and SCL signals	t_f	—	300	$20 + 0.1C_b$ ⁵	300	ns
Set-up time for STOP condition	$t_{SU}; STO$	4	—	0.6	—	μs
Bus free time between STOP and START condition	t_{BUF}	4.7	—	1.3	—	μs
Pulse width of spikes that must be suppressed by the input filter	t_{SP}	N/A	N/A	0	50	ns

1. The master mode I²C deasserts ACK of an address byte simultaneously with the falling edge of SCL. If no slaves acknowledge this address byte, then a negative hold time can result, depending on the edge rates of the SDA and SCL lines.
2. The maximum $t_{HD}; DAT$ must be met only if the device does not stretch the LOW period (t_{LOW}) of the SCL signal.
3. Input signal Slew = 10 ns and Output Load = 50 pF
4. Set-up time in slave-transmitter mode is 1 IPBus clock period, if the TX FIFO is empty.
5. A Fast mode I²C bus device can be used in a Standard mode I²C bus system, but the requirement $t_{SU}; DAT \geq 250$ ns must then be met. This is automatically the case if the device does not stretch the LOW period of the SCL signal. If such

- a device does stretch the LOW period of the SCL signal, then it must output the next data bit to the SDA line $t_{rmax} + t_{SU}$; $t_{HD; DAT} = 1000 + 250 = 1250$ ns (according to the Standard mode I²C bus specification) before the SCL line is released.
6. C_b = total capacitance of the one bus line in pF.

Table 52. I²C 1 Mbps timing

Characteristic	Symbol	Minimum	Maximum	Unit
SCL Clock Frequency	f_{SCL}	0	1 ¹	MHz
Hold time (repeated) START condition. After this period, the first clock pulse is generated.	$t_{HD; STA}$	0.26	—	μ s
LOW period of the SCL clock	t_{LOW}	0.5	—	μ s
HIGH period of the SCL clock	t_{HIGH}	0.26	—	μ s
Set-up time for a repeated START condition	$t_{SU; STA}$	0.26	—	μ s
Data hold time for I ² C bus devices	$t_{HD; DAT}$	0	—	μ s
Data set-up time	$t_{SU; DAT}$	50	—	ns
Rise time of SDA and SCL signals	t_r	$20 + 0.1C_b$ ²	120	ns
Fall time of SDA and SCL signals	t_f	$20 + 0.1C_b$ ²	120	ns
Set-up time for STOP condition	$t_{SU; STO}$	0.26	—	μ s
Bus free time between STOP and START condition	t_{BUF}	0.5	—	μ s
Pulse width of spikes that must be suppressed by the input filter	t_{SP}	0	50	ns

- The maximum SCL clock frequency of 1 Mbps can support maximum bus loading when using the High drive pins across the full voltage range.
- C_b = total capacitance of the one bus line in pF.

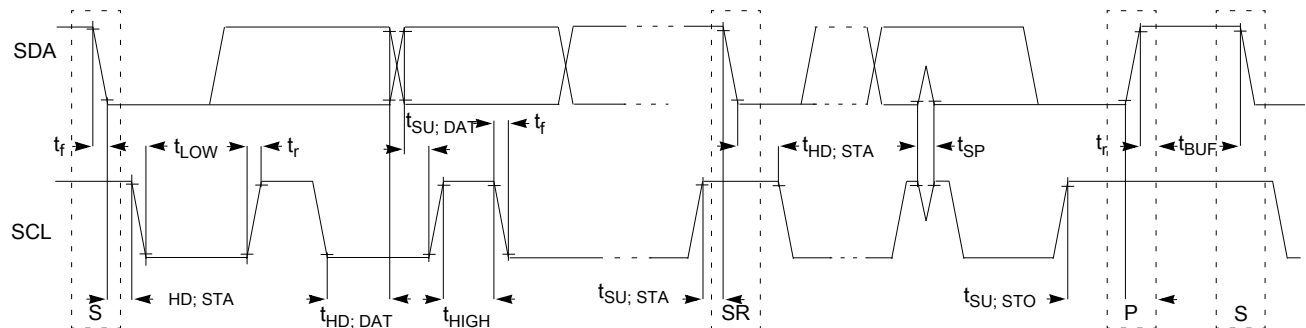
**Figure 31. Timing definition for devices on the I²C bus**

3.8.9 UART switching specifications

See [General switching specifications](#).

3.8.10 Low Power UART switching specifications

See [General switching specifications](#).

3.8.11 SDHC specifications

The following timing specs are defined at the chip I/O pin and must be translated appropriately to arrive at timing specs/constraints for the physical interface.

Table 53. SDHC full voltage range switching specifications

Num	Symbol	Description	Min.	Max.	Unit
		Operating voltage	1.71	3.6	V
Card input clock					
SD1	fpp	Clock frequency (low speed)	0	400	kHz
	fpp	Clock frequency (SD\SDIO full speed\high speed)	0	25\50	MHz
	fpp	Clock frequency (MMC full speed\high speed)	0	20\50	MHz
	f _{OD}	Clock frequency (identification mode)	0	400	kHz
SD2	t _{WL}	Clock low time	7	—	ns
SD3	t _{WH}	Clock high time	7	—	ns
SD4	t _{TLH}	Clock rise time	—	3	ns
SD5	t _{THL}	Clock fall time	—	3	ns
SDHC output / card inputs SDHC_CMD, SDHC_DAT (reference to SDHC_CLK)					
SD6	t _{OD}	SDHC output delay (output valid)	-5	8.6 8.3	ns
SDHC input / card inputs SDHC_CMD, SDHC_DAT (reference to SDHC_CLK)					
SD7	t _{ISU}	SDHC input setup time	5	—	ns
SD8	t _{IH}	SDHC input hold time	0	—	ns

Table 54. SDHC limited voltage range switching specifications

Num	Symbol	Description	Min.	Max.	Unit
		Operating voltage	2.7	3.6	V
Card input clock					
SD1	fpp	Clock frequency (low speed)	0	400	kHz
	fpp	Clock frequency (SD\SDIO full speed\high speed)	0	25\50	MHz
	fpp	Clock frequency (MMC full speed\high speed)	0	20\50	MHz
	f _{OD}	Clock frequency (identification mode)	0	400	kHz
SD2	t _{WL}	Clock low time	7	—	ns
SD3	t _{WH}	Clock high time	7	—	ns
SD4	t _{TLH}	Clock rise time	—	3	ns
SD5	t _{THL}	Clock fall time	—	3	ns

Table continues on the next page...

Table 54. SDHC limited voltage range switching specifications (continued)

Num	Symbol	Description	Min.	Max.	Unit
SDHC output / card inputs SDHC_CMD, SDHC_DAT (reference to SDHC_CLK)					
SD6	t_{OD}	SDHC output delay (output valid)	-5	7.6 8.3	ns
SDHC input / card inputs SDHC_CMD, SDHC_DAT (reference to SDHC_CLK)					
SD7	t_{ISU}	SDHC input setup time	5	—	ns
SD8	t_{IH}	SDHC input hold time	0	—	ns

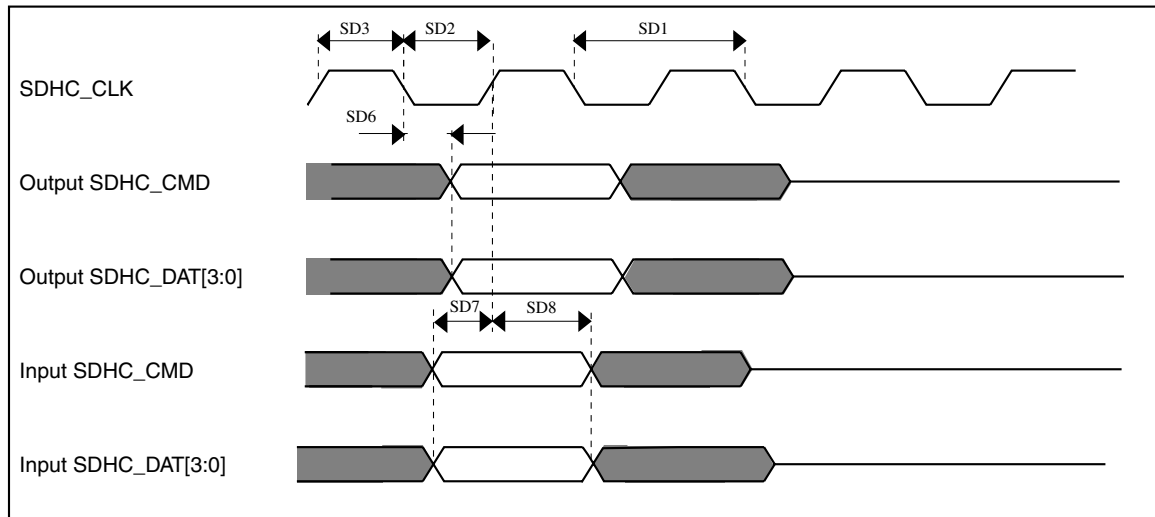
**Figure 32. SDHC timing**

3.8.12 I²S switching specifications

This section provides the AC timings for the I²S in master (clocks driven) and slave modes (clocks input). All timings are given for non-inverted serial clock polarity (TCR[TSCKP] = 0, RCR[RSCKP] = 0) and a non-inverted frame sync (TCR[TFISI] = 0, RCR[RFSI] = 0). If the polarity of the clock and/or the frame sync have been inverted, all the timings remain valid by inverting the clock signal (I2S_BCLK) and/or the frame sync (I2S_FS) shown in the figures below.

Table 55. I2S master mode timing (limited voltage range)

Num	Description	Min.	Max.	Unit
	Operating voltage	2.7	3.6	V
S1	I2S_MCLK cycle time	40	—	ns
S2	I2S_MCLK pulse width high/low	45%	55%	MCLK period
S3	I2S_BCLK cycle time	80	—	ns

Table continues on the next page...

Table 55. I2S master mode timing (limited voltage range) (continued)

Num	Description	Min.	Max.	Unit
S4	I2S_BCLK pulse width high/low	45%	55%	BCLK period
S5	I2S_BCLK to I2S_FS output valid	—	15	ns
S6	I2S_BCLK to I2S_FS output invalid	0	—	ns
S7	I2S_BCLK to I2S_TXD valid	—	15	ns
S8	I2S_BCLK to I2S_TXD invalid	0	—	ns
S9	I2S_RXD/I2S_FS input setup before I2S_BCLK	15	—	ns
S10	I2S_RXD/I2S_FS input hold after I2S_BCLK	0	—	ns

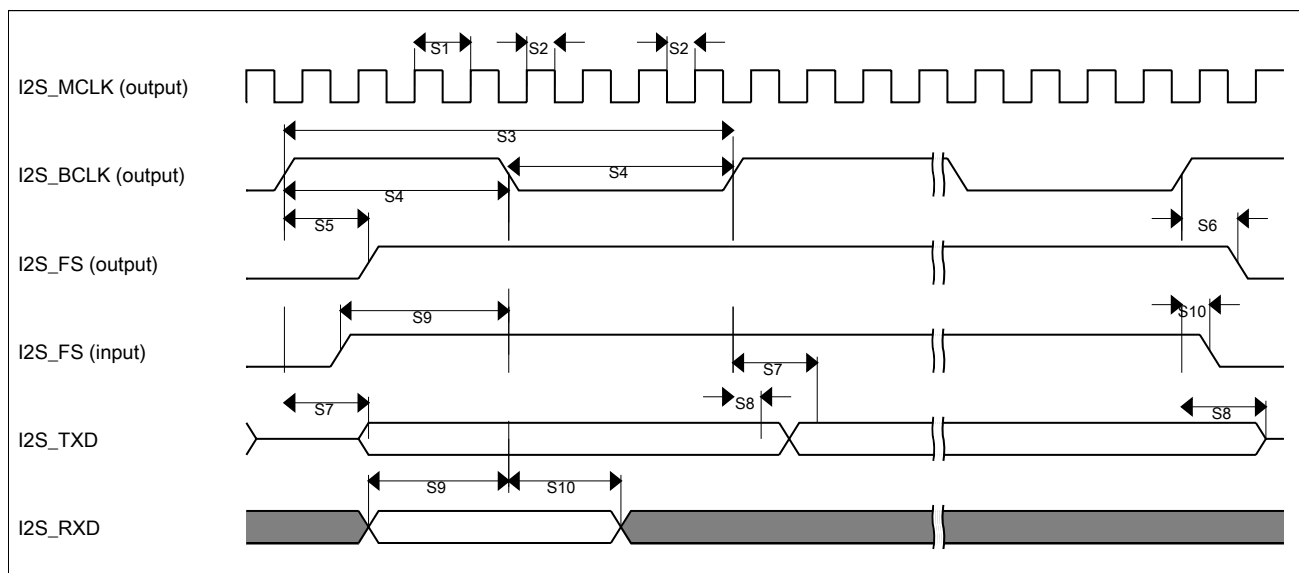
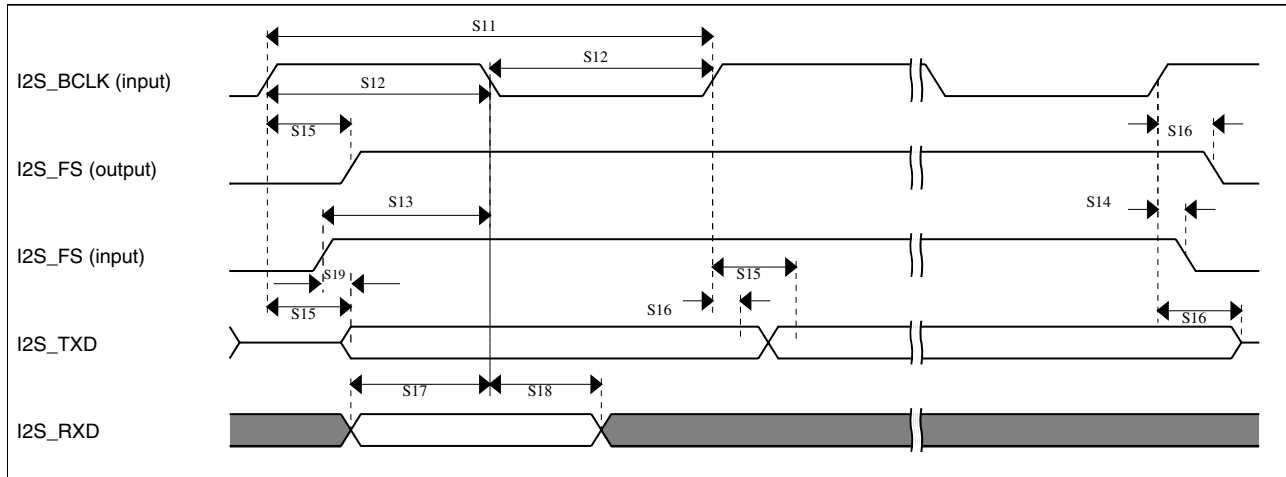

Figure 33. I2S timing — master mode

Table 56. I2S slave mode timing (limited voltage range)

Num	Description	Min.	Max.	Unit
	Operating voltage	2.7	3.6	V
S11	I2S_BCLK cycle time (input)	80	—	ns
S12	I2S_BCLK pulse width high/low (input)	45%	55%	MCLK period
S13	I2S_FS input setup before I2S_BCLK	4.5	—	ns
S14	I2S_FS input hold after I2S_BCLK	2	—	ns
S15	I2S_BCLK to I2S_TXD/I2S_FS output valid	—	20	ns
S16	I2S_BCLK to I2S_TXD/I2S_FS output invalid	0	—	ns
S17	I2S_RXD setup before I2S_BCLK	4.5	—	ns
S18	I2S_RXD hold after I2S_BCLK	2	—	ns
S19	I2S_TX_FS input assertion to I2S_TXD output valid ¹		25	ns

1. Applies to first bit in each frame and only if the TCR4[FSE] bit is clear

Figure 34. I²S timing — slave modes

3.8.12.1 Normal Run, Wait and Stop mode performance over the full operating voltage range

This section provides the operating performance over the full operating voltage for the device in Normal Run, Wait and Stop modes.

Table 57. I2S/SAI master mode timing

Num.	Characteristic	Min.	Max.	Unit
	Operating voltage	1.71	3.6	V
S1	I2S_MCLK cycle time	40	—	ns
S2	I2S_MCLK (as an input) pulse width high/low	45%	55%	MCLK period
S3	I2S_TX_BCLK/I2S_RX_BCLK cycle time (output)	80	—	ns
S4	I2S_TX_BCLK/I2S_RX_BCLK pulse width high/low	45%	55%	BCLK period
S5	I2S_TX_BCLK/I2S_RX_BCLK to I2S_TX_FS/ I2S_RX_FS output valid	—	15	ns
S6	I2S_TX_BCLK/I2S_RX_BCLK to I2S_TX_FS/ I2S_RX_FS output invalid	0	—	ns
S7	I2S_TX_BCLK to I2S_TXD valid	—	15	ns
S8	I2S_TX_BCLK to I2S_TXD invalid	0	—	ns
S9	I2S_RXD/I2S_RX_FS input setup before I2S_RX_BCLK	15	—	ns
S10	I2S_RXD/I2S_RX_FS input hold after I2S_RX_BCLK	0	—	ns

Peripheral operating requirements and behaviors

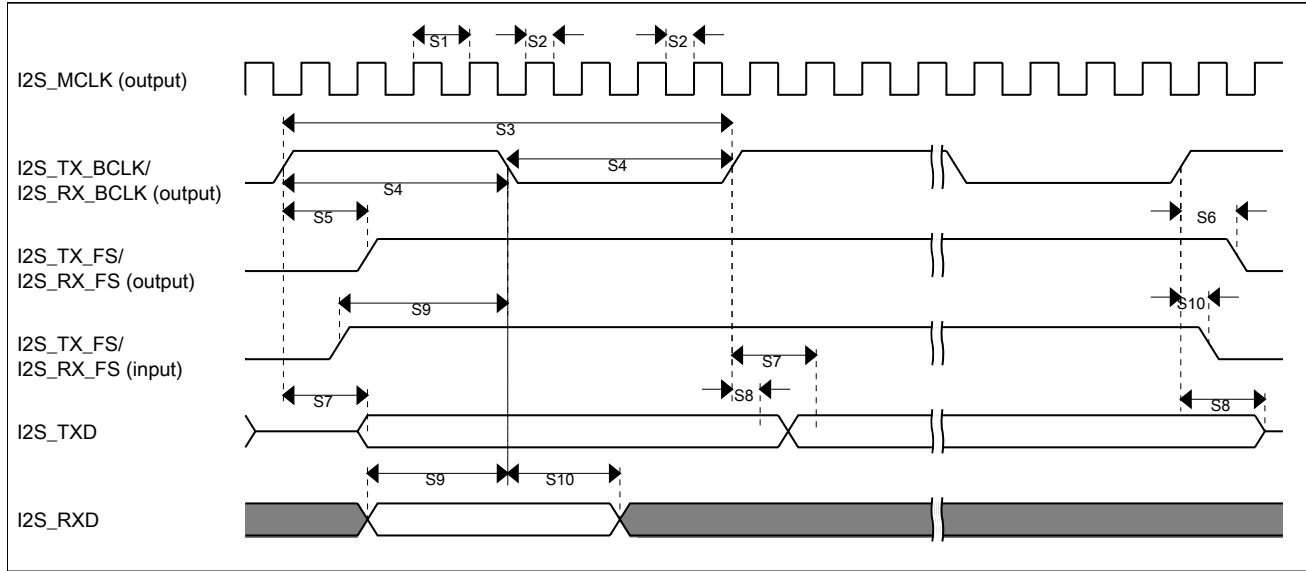

Figure 35. I2S/SAI timing — master modes

Table 58. I2S/SAI slave mode timing

Num.	Characteristic	Min.	Max.	Unit
	Operating voltage	1.71	3.6	V
S11	I2S_TX_BCLK/I2S_RX_BCLK cycle time (input)	80	—	ns
S12	I2S_TX_BCLK/I2S_RX_BCLK pulse width high/low (input)	45%	55%	MCLK period
S13	I2S_TX_FS/I2S_RX_FS input setup before I2S_TX_BCLK/I2S_RX_BCLK	4.5	—	ns
S14	I2S_TX_FS/I2S_RX_FS input hold after I2S_TX_BCLK/I2S_RX_BCLK	2	—	ns
S15	I2S_TX_BCLK to I2S_TXD/I2S_TX_FS output valid	—	23.1	ns
S16	I2S_TX_BCLK to I2S_TXD/I2S_TX_FS output invalid	0	—	ns
S17	I2S_RXD setup before I2S_RX_BCLK	4.5	—	ns
S18	I2S_RXD hold after I2S_RX_BCLK	2	—	ns
S19	I2S_TX_FS input assertion to I2S_TXD output valid ¹	—	25	ns

1. Applies to first bit in each frame and only if the TCR4[FSE] bit is clear

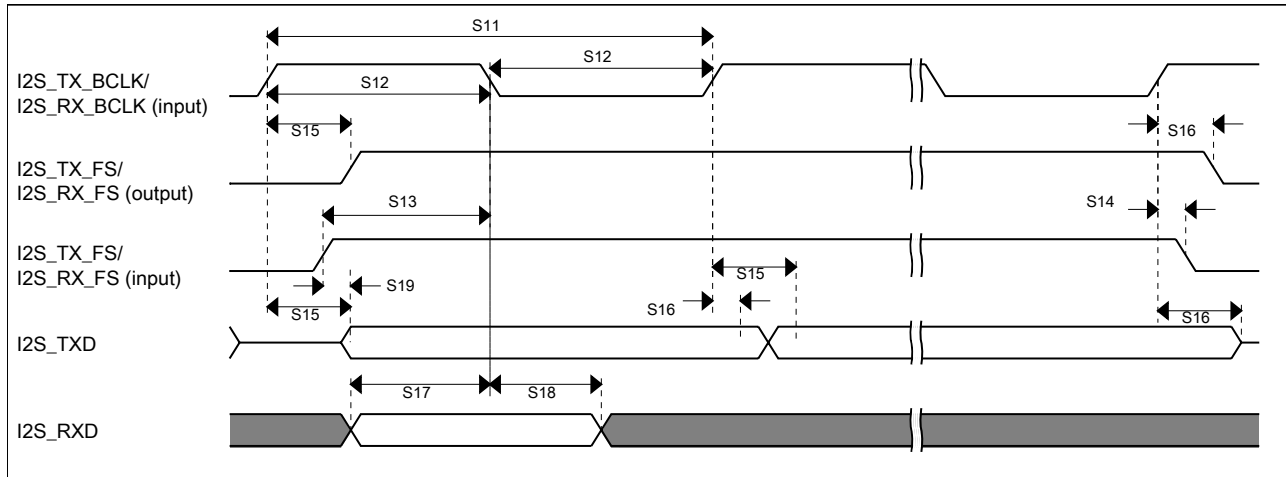

Figure 36. I2S/SAI timing — slave modes

3.8.12.2 VLPR, VLPW, and VLPS mode performance over the full operating voltage range

This section provides the operating performance over the full operating voltage for the device in VLPR, VLPW, and VLPS modes.

Table 59. I2S/SAI master mode timing in VLPR, VLPW, and VLPS modes (full voltage range)

Num.	Characteristic	Min.	Max.	Unit
	Operating voltage	1.71	3.6	V
S1	I2S_MCLK cycle time	62.5	—	ns
S2	I2S_MCLK pulse width high/low	45%	55%	MCLK period
S3	I2S_TX_BCLK/I2S_RX_BCLK cycle time (output)	250	—	ns
S4	I2S_TX_BCLK/I2S_RX_BCLK pulse width high/low	45%	55%	BCLK period
S5	I2S_TX_BCLK/I2S_RX_BCLK to I2S_TX_FS/ I2S_RX_FS output valid	—	45	ns
S6	I2S_TX_BCLK/I2S_RX_BCLK to I2S_TX_FS/ I2S_RX_FS output invalid	0	—	ns
S7	I2S_TX_BCLK to I2S_TXD valid	—	45	ns
S8	I2S_TX_BCLK to I2S_TXD invalid	0	—	ns
S9	I2S_RXD/I2S_RX_FS input setup before I2S_RX_BCLK	45	—	ns
S10	I2S_RXD/I2S_RX_FS input hold after I2S_RX_BCLK	0	—	ns

Peripheral operating requirements and behaviors

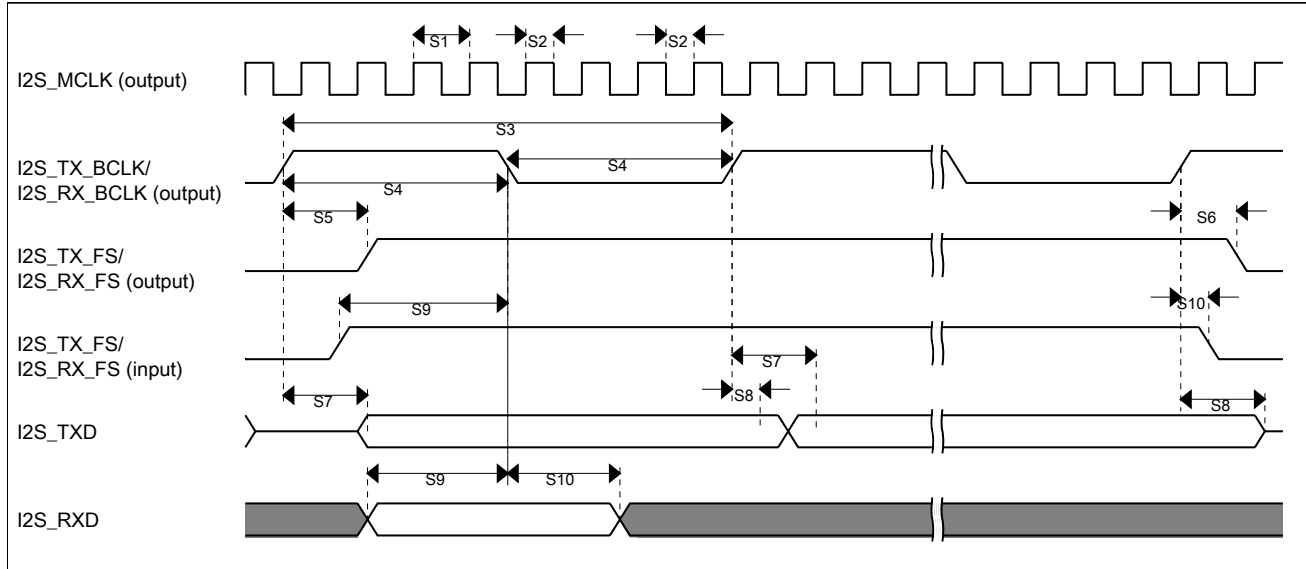

Figure 37. I2S/SAI timing — master modes

Table 60. I2S/SAI slave mode timing in VLPR, VLPW, and VLPS modes (full voltage range)

Num.	Characteristic	Min.	Max.	Unit
	Operating voltage	1.71	3.6	V
S11	I2S_TX_BCLK/I2S_RX_BCLK cycle time (input)	250	—	ns
S12	I2S_TX_BCLK/I2S_RX_BCLK pulse width high/low (input)	45%	55%	MCLK period
S13	I2S_TX_FS/I2S_RX_FS input setup before I2S_TX_BCLK/I2S_RX_BCLK	30	—	ns
S14	I2S_TX_FS/I2S_RX_FS input hold after I2S_TX_BCLK/I2S_RX_BCLK	5	—	ns
S15	I2S_TX_BCLK to I2S_TXD/I2S_TX_FS output valid	—	56.5	ns
S16	I2S_TX_BCLK to I2S_TXD/I2S_TX_FS output invalid	0	—	ns
S17	I2S_RXD setup before I2S_RX_BCLK	30	—	ns
S18	I2S_RXD hold after I2S_RX_BCLK	5	—	ns
S19	I2S_TX_FS input assertion to I2S_TXD output valid ¹	—	72	ns

1. Applies to first bit in each frame and only if the TCR4[FSE] bit is clear

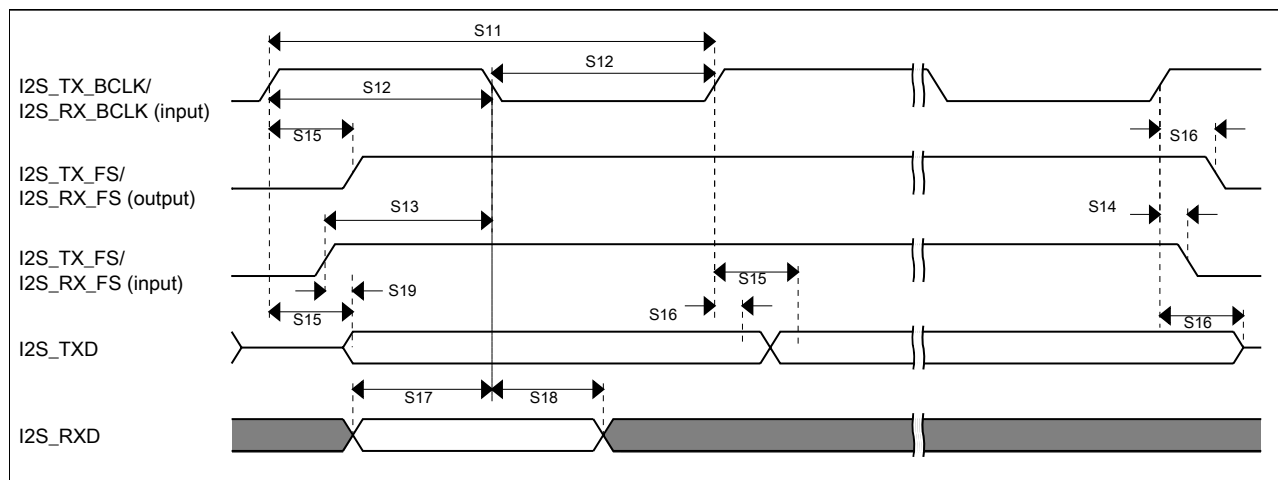

Figure 38. I2S/SAI timing — slave modes

3.9 Human-machine interfaces (HMI)

3.9.1 TSI electrical specifications

Table 61. TSI electrical specifications

Symbol	Description	Min.	Typ.	Max.	Unit
TSI_RUNF	Fixed power consumption in run mode	—	100	—	μA
TSI_RUNV	Variable power consumption in run mode (depends on oscillator's current selection)	1.0	—	128	μA
TSI_EN	Power consumption in enable mode	—	100	—	μA
TSI_DIS	Power consumption in disable mode	—	1.2	—	μA
TSI_TEN	TSI analog enable time	—	66	—	μs
TSI_CREF	TSI reference capacitor	—	1.0	—	pF
TSI_DVOLT	Voltage variation of VP & VM around nominal values	0.19	—	1.03	V

4 Dimensions

4.1 Obtaining package dimensions

Package dimensions are provided in package drawings.

Pinout

To find a package drawing, go to nxp.com and perform a keyword search for the drawing's document number:

If you want the drawing for this package	Then use this document number
144-pin LQFP	98ASS23177W
144-pin MAPBGA	98ASA00222D

5 Pinout

5.1 K66 Signal Multiplexing and Pin Assignments

The following table shows the signals available on each pin and the locations of these pins on the devices supported by this document. The Port Control Module is responsible for selecting which ALT functionality is available on each pin.

144 LQFP	144 MAP BGA	Pin Name	Default	ALT0	ALT1	ALT2	ALT3	ALT4	ALT5	ALT6	ALT7	EzPort
—	L5	RTC_WAKEUP_B	RTC_WAKEUP_B	RTC_WAKEUP_B								
—	M5	NC	NC	NC								
—	A10	NC	NC	NC								
—	B10	NC	NC	NC								
—	C10	NC	NC	NC								
1	D3	PTE0	ADC1_SE4a	ADC1_SE4a	PTE0	SPI1_PCS1	UART1_TX	SDHC0_D1	TRACE_CLKOUT	I2C1_SDA	RTC_CLKOUT	
2	D2	PTE1/LLWU_P0	ADC1_SE5a	ADC1_SE5a	PTE1/LLWU_P0	SPI1_SOUT	UART1_RX	SDHC0_D0	TRACE_D3	I2C1_SCL	SPI1_SIN	
3	D1	PTE2/LLWU_P1	ADC1_SE6a	ADC1_SE6a	PTE2/LLWU_P1	SPI1_SCK	UART1_CTS_b	SDHC0_DCLK	TRACE_D2			
4	E4	PTE3	ADC1_SE7a	ADC1_SE7a	PTE3	SPI1_SIN	UART1_RTS_b	SDHC0_CMD	TRACE_D1		SPI1_SOUT	
5	E5	VDD	VDD	VDD								
6	H3	VSS	VSS	VSS								
7	E3	PTE4/LLWU_P2	DISABLED		PTE4/LLWU_P2	SPI1_PCS0	UART3_TX	SDHC0_D3	TRACE_D0			
8	E2	PTE5	DISABLED		PTE5	SPI1_PCS2	UART3_RX	SDHC0_D2		FTM3_CH0		
9	E1	PTE6/LLWU_P16	DISABLED		PTE6/LLWU_P16	SPI1_PCS3	UART3_CTS_b	I2S0_MCLK		FTM3_CH1	USB0_SOF_OUT	
10	F4	PTE7	DISABLED		PTE7		UART3_RTS_b	I2S0_RXD0		FTM3_CH2		

144 LQFP	144 MAP BGA	Pin Name	Default	ALT0	ALT1	ALT2	ALT3	ALT4	ALT5	ALT6	ALT7	EzPort
11	F3	PTE8	DISABLED		PTE8	I2S0_RXD1		I2S0_RX_FS	LPUART0_TX	FTM3_CH3		
12	F2	PTE9/ LLWU_P17	DISABLED		PTE9/ LLWU_P17	I2S0_TXD1		I2S0_RX_BCLK	LPUART0_RX	FTM3_CH4		
13	F1	PTE10/ LLWU_P18	DISABLED		PTE10/ LLWU_P18	I2C3_SDA		I2S0_TXD0	LPUART0_CTS_b	FTM3_CH5	USB1_ID	
14	G4	PTE11	DISABLED		PTE11	I2C3_SCL		I2S0_TX_FS	LPUART0_RTS_b	FTM3_CH6		
15	G3	PTE12	DISABLED		PTE12			I2S0_TX_BCLK		FTM3_CH7		
16	E6	VDD	VDD	VDD								
17	F7	VSS	VSS	VSS								
18	F6	VSS	VSS	VSS								
19	H1	USB0_DP	USB0_DP	USB0_DP								
20	H2	USB0_DM	USB0_DM	USB0_DM								
21	G1	VREG_OUT	VREG_OUT	VREG_OUT								
22	G2	VREG_IN0	VREG_IN0	VREG_IN0								
23	J2	VREG_IN1	DISABLED	VREG_IN1								
24	K2	USB1_VSS	DISABLED	USB1_VSS								
25	J1	USB1_DP	DISABLED	USB1_DP								
26	K1	USB1_DM	DISABLED	USB1_DM								
27	L1	USB1_VBUS	DISABLED	USB1_VBUS								
28	L2	ADC0_DM0/ ADC1_DM3	ADC0_DM0/ ADC1_DM3	ADC0_DM0/ ADC1_DM3								
29	M1	ADC1_DP0/ ADC0_DP3	ADC1_DP0/ ADC0_DP3	ADC1_DP0/ ADC0_DP3								
30	M2	ADC1_DM0/ ADC0_DM3	ADC1_DM0/ ADC0_DM3	ADC1_DM0/ ADC0_DM3								
31	H5	VDDA	VDDA	VDDA								
32	G5	VREFH	VREFH	VREFH								
33	G6	VREFL	VREFL	VREFL								
34	H6	VSSA	VSSA	VSSA								
35	K3	ADC1_SE16/ CMP2_IN2/ ADC0_SE22	ADC1_SE16/ CMP2_IN2/ ADC0_SE22	ADC1_SE16/ CMP2_IN2/ ADC0_SE22								
36	J3	ADC0_SE16/ CMP1_IN2/ ADC0_SE21	ADC0_SE16/ CMP1_IN2/ ADC0_SE21	ADC0_SE16/ CMP1_IN2/ ADC0_SE21								
37	M3	VREF_OUT/ CMP1_IN5/ CMP0_IN5/ ADC1_SE18	VREF_OUT/ CMP1_IN5/ CMP0_IN5/ ADC1_SE18	VREF_OUT/ CMP1_IN5/ CMP0_IN5/ ADC1_SE18								

Pinout

144 LQFP	144 MAP BGA	Pin Name	Default	ALT0	ALT1	ALT2	ALT3	ALT4	ALT5	ALT6	ALT7	EzPort
38	L3	DAC0_OUT/ CMP1_IN3/ ADC0_SE23	DAC0_OUT/ CMP1_IN3/ ADC0_SE23	DAC0_OUT/ CMP1_IN3/ ADC0_SE23								
39	L4	DAC1_OUT/ CMP0_IN4/ CMP2_IN3/ ADC1_SE23	DAC1_OUT/ CMP0_IN4/ CMP2_IN3/ ADC1_SE23	DAC1_OUT/ CMP0_IN4/ CMP2_IN3/ ADC1_SE23								
40	M7	XTAL32	XTAL32	XTAL32								
41	M6	EXTAL32	EXTAL32	EXTAL32								
42	L6	VBAT	VBAT	VBAT								
43	—	VDD	VDD	VDD								
44	—	VSS	VSS	VSS								
45	M4	PTE24	ADC0_SE17	ADC0_SE17	PTE24	CAN1_TX	UART4_TX		I2C0_SCL	EWM_OUT_b		
46	K5	PTE25/ LLWU_P21	ADC0_SE18	ADC0_SE18	PTE25/ LLWU_P21	CAN1_RX	UART4_RX		I2C0_SDA	EWM_IN		
47	K4	PTE26	DISABLED		PTE26	ENET_1588_CLKIN	UART4_CTS_b			RTC_CLKOUT	USB0_CLKIN	
48	J4	PTE27	DISABLED		PTE27		UART4_RTS_b					
49	H4	PTE28	DISABLED		PTE28							
50	J5	PTA0	JTAG_TCLK/ SWD_CLK/ EZP_CLK	TSIO_CH1	PTA0	UART0_CTS_b/ UART0_COL_b	FTM0_CH5		LPUART0_CTS_b		JTAG_TCLK/ SWD_CLK	EZP_CLK
51	J6	PTA1	JTAG_TDI/ EZP_DI	TSIO_CH2	PTA1	UART0_RX	FTM0_CH6	I2C3_SDA	LPUART0_RX		JTAG_TDI	EZP_DI
52	K6	PTA2	JTAG_TDO/ TRACE_SWO/ EZP_DO	TSIO_CH3	PTA2	UART0_TX	FTM0_CH7	I2C3_SCL	LPUART0_TX		JTAG_TDO/ TRACE_SWO	EZP_DO
53	K7	PTA3	JTAG_TMS/ SWD_DIO	TSIO_CH4	PTA3	UART0_RTS_b	FTM0_CH0		LPUART0_RTS_b		JTAG_TMS/ SWD_DIO	
54	L7	PTA4/ LLWU_P3	NMI_b/ EZP_CS_b	TSIO_CH5	PTA4/ LLWU_P3		FTM0_CH1				NMI_b	EZP_CS_b
55	M8	PTA5	DISABLED		PTA5	USB0_CLKIN	FTM0_CH2	RMII0_RXER/ MII0_RXER	CMP2_OUT	I2S0_TX_BCLK	JTAG_TRST_b	
56	E7	VDD	VDD	VDD								
57	G7	VSS	VSS	VSS								
58	J7	PTA6	DISABLED		PTA6		FTM0_CH3		CLKOUT		TRACE_CLKOUT	
59	J8	PTA7	ADC0_SE10	ADC0_SE10	PTA7		FTM0_CH4		RMII0_MDIO/ MII0_MDIO		TRACE_D3	

144 LQFP	144 MAP BGA	Pin Name	Default	ALT0	ALT1	ALT2	ALT3	ALT4	ALT5	ALT6	ALT7	EzPort
60	K8	PTA8	ADC0_SE11	ADC0_SE11	PTA8		FTM1_CH0		RMIIO_MDC/ MII0_MDC	FTM1_QD_ PHA/ TPM1_CH0	TRACE_D2	
61	L8	PTA9	DISABLED		PTA9		FTM1_CH1	MII0_RXD3		FTM1_QD_ PHB/ TPM1_CH1	TRACE_D1	
62	M9	PTA10/ LLWU_P22	DISABLED		PTA10/ LLWU_P22		FTM2_CH0	MII0_RXD2		FTM2_QD_ PHA/ TPM2_CH0	TRACE_D0	
63	L9	PTA11/ LLWU_P23	DISABLED		PTA11/ LLWU_P23		FTM2_CH1	MII0_RXCLK	I2C2_SDA	FTM2_QD_ PHB/ TPM2_CH1		
64	K9	PTA12	CMP2_IN0	CMP2_IN0	PTA12	CAN0_TX	FTM1_CH0	RMIIO_ RXD1/ MII0_RXD1	I2C2_SCL	I2S0_TXD0	FTM1_QD_ PHA/ TPM1_CH0	
65	J9	PTA13/ LLWU_P4	CMP2_IN1	CMP2_IN1	PTA13/ LLWU_P4	CAN0_RX	FTM1_CH1	RMIIO_ RXD0/ MII0_RXD0	I2C2_SDA	I2S0_TX_FS	FTM1_QD_ PHB/ TPM1_CH1	
66	L10	PTA14	DISABLED		PTA14	SPI0_PCS0	UART0_TX	RMIIO_CRS_ DV/ MII0_RXDV	I2C2_SCL	I2S0_RX_ BCLK	I2S0_TXD1	
67	L11	PTA15	CMP3_IN1	CMP3_IN1	PTA15	SPI0_SCK	UART0_RX	RMIIO_ TXEN/ MII0_TXEN		I2S0_RXD0		
68	K10	PTA16	CMP3_IN2	CMP3_IN2	PTA16	SPI0_SOUT	UART0_ CTS_b/ UART0_ COL_b	RMIIO_TXD0/ MII0_TXD0		I2S0_RX_FS	I2S0_RXD1	
69	K11	PTA17	ADC1_SE17	ADC1_SE17	PTA17	SPI0_SIN	UART0_ RTS_b	RMIIO_TXD1/ MII0_TXD1		I2S0_MCLK		
70	E8	VDD	VDD	VDD								
71	G8	VSS	VSS	VSS								
72	M12	PTA18	EXTAL0	EXTAL0	PTA18		FTM0_FLT2	FTM_CLKIN0			TPM_ CLKIN0	
73	M11	PTA19	XTAL0	XTAL0	PTA19		FTM1_FLT0	FTM_CLKIN1		LPTMR0_ ALT1	TPM_ CLKIN1	
74	L12	RESET_b	RESET_b	RESET_b								
75	K12	PTA24	CMP3_IN4	CMP3_IN4	PTA24			MII0_TXD2		FB_A29		
76	J12	PTA25	CMP3_IN5	CMP3_IN5	PTA25			MII0_TXCLK		FB_A28		
77	J11	PTA26	DISABLED		PTA26			MII0_TXD3		FB_A27		
78	J10	PTA27	DISABLED		PTA27			MII0_CRS		FB_A26		
79	H12	PTA28	DISABLED		PTA28			MII0_TXER		FB_A25		
80	H11	PTA29	DISABLED		PTA29			MII0_COL		FB_A24		
81	H10	PTB0/ LLWU_P5	ADC0_SE8/ ADC1_SE8/ TSI0_CH0	ADC0_SE8/ ADC1_SE8/ TSI0_CH0	PTB0/ LLWU_P5	I2C0_SCL	FTM1_CH0	RMIIO_MDIO/ MII0_MDIO	SDRAM_ CAS_b	FTM1_QD_ PHA/ TPM1_CH0		

Pinout

144 LQFP	144 MAP BGA	Pin Name	Default	ALT0	ALT1	ALT2	ALT3	ALT4	ALT5	ALT6	ALT7	EzPort
82	H9	PTB1	ADC0_SE9/ ADC1_SE9/ TSIO_CH6	ADC0_SE9/ ADC1_SE9/ TSIO_CH6	PTB1	I2C0_SDA	FTM1_CH1	RMII0_MDC/ MII0_MDC	SDRAM_ RAS_b	FTM1_QD_ PHB/ TPM1_CH1		
83	G12	PTB2	ADC0_SE12/ TSIO_CH7	ADC0_SE12/ TSIO_CH7	PTB2	I2C0_SCL	UART0_ RTS_b	ENET0_ 1588_TMR0	SDRAM_WE	FTM0_FLT3		
84	G11	PTB3	ADC0_SE13/ TSIO_CH8	ADC0_SE13/ TSIO_CH8	PTB3	I2C0_SDA	UART0_ CTS_b/ UART0_ COL_b	ENET0_ 1588_TMR1	SDRAM_ CS0_b	FTM0_FLT0		
85	G10	PTB4	ADC1_SE10	ADC1_SE10	PTB4			ENET0_ 1588_TMR2	SDRAM_ CS1_b	FTM1_FLT0		
86	G9	PTB5	ADC1_SE11	ADC1_SE11	PTB5			ENET0_ 1588_TMR3		FTM2_FLT0		
87	F12	PTB6	ADC1_SE12	ADC1_SE12	PTB6				FB_AD23/ SDRAM_D23			
88	F11	PTB7	ADC1_SE13	ADC1_SE13	PTB7				FB_AD22/ SDRAM_D22			
89	F10	PTB8	DISABLED		PTB8		UART3_ RTS_b		FB_AD21/ SDRAM_D21			
90	F9	PTB9	DISABLED		PTB9	SPI1_PCS1	UART3_ CTS_b		FB_AD20/ SDRAM_D20			
91	E12	PTB10	ADC1_SE14	ADC1_SE14	PTB10	SPI1_PCS0	UART3_RX		FB_AD19/ SDRAM_D19	FTM0_FLT1		
92	E11	PTB11	ADC1_SE15	ADC1_SE15	PTB11	SPI1_SCK	UART3_TX		FB_AD18/ SDRAM_D18	FTM0_FLT2		
93	H7	VSS	VSS	VSS								
94	F5	VDD	VDD	VDD								
95	E10	PTB16	TSIO_CH9	TSIO_CH9	PTB16	SPI1_SOUT	UART0_RX	FTM_CLKIN0	FB_AD17/ SDRAM_D17	EWM_IN	TPM_ CLKIN0	
96	E9	PTB17	TSIO_CH10	TSIO_CH10	PTB17	SPI1_SIN	UART0_TX	FTM_CLKIN1	FB_AD16/ SDRAM_D16	EWM_OUT_ b	TPM_ CLKIN1	
97	D12	PTB18	TSIO_CH11	TSIO_CH11	PTB18	CAN0_TX	FTM2_CH0	I2S0_TX_ BCLK	FB_AD15/ SDRAM_A23	FTM2_QD_ PHA/ TPM2_CH0		
98	D11	PTB19	TSIO_CH12	TSIO_CH12	PTB19	CAN0_RX	FTM2_CH1	I2S0_TX_FS	FB_OE_b	FTM2_QD_ PHB/ TPM2_CH1		
99	D10	PTB20	DISABLED		PTB20	SPI2_PCS0			FB_AD31/ SDRAM_D31	CMP0_OUT		
100	D9	PTB21	DISABLED		PTB21	SPI2_SCK			FB_AD30/ SDRAM_D30	CMP1_OUT		
101	C12	PTB22	DISABLED		PTB22	SPI2_SOUT			FB_AD29/ SDRAM_D29	CMP2_OUT		
102	C11	PTB23	DISABLED		PTB23	SPI2_SIN	SPI0_PCS5		FB_AD28/ SDRAM_D28	CMP3_OUT		

144 LQFP	144 MAP BGA	Pin Name	Default	ALT0	ALT1	ALT2	ALT3	ALT4	ALT5	ALT6	ALT7	EzPort
103	B12	PTC0	ADC0_SE14/ TSIO_CH13	ADC0_SE14/ TSIO_CH13	PTC0	SPI0_PCS4	PDB0_ EXTRG	USB0_SOF_ OUT	FB_AD14/ SDRAM_A22	I2S0_TXD1		
104	B11	PTC1/ LLWU_P6	ADC0_SE15/ TSIO_CH14	ADC0_SE15/ TSIO_CH14	PTC1/ LLWU_P6	SPI0_PCS3	UART1_ RTS_b	FTM0_CH0	FB_AD13/ SDRAM_A21	I2S0_TXD0		
105	A12	PTC2	ADC0_SE4b/ CMP1_IN0/ TSIO_CH15	ADC0_SE4b/ CMP1_IN0/ TSIO_CH15	PTC2	SPI0_PCS2	UART1_ CTS_b	FTM0_CH1	FB_AD12/ SDRAM_A20	I2S0_TX_FS		
106	A11	PTC3/ LLWU_P7	CMP1_IN1	CMP1_IN1	PTC3/ LLWU_P7	SPI0_PCS1	UART1_RX	FTM0_CH2	CLKOUT	I2S0_TX_ BCLK		
107	H8	VSS	VSS	VSS								
108	—	VDD	VDD	VDD								
109	A9	PTC4/ LLWU_P8	DISABLED		PTC4/ LLWU_P8	SPI0_PCS0	UART1_TX	FTM0_CH3	FB_AD11/ SDRAM_A19	CMP1_OUT		
110	D8	PTC5/ LLWU_P9	DISABLED		PTC5/ LLWU_P9	SPI0_SCK	LPTMR0_ ALT2	I2S0_RXD0	FB_AD10/ SDRAM_A18	CMP0_OUT	FTM0_CH2	
111	C8	PTC6/ LLWU_P10	CMP0_IN0	CMP0_IN0	PTC6/ LLWU_P10	SPI0_SOUT	PDB0_ EXTRG	I2S0_RX_ BCLK	FB_AD9/ SDRAM_A17	I2S0_MCLK		
112	B8	PTC7	CMP0_IN1	CMP0_IN1	PTC7	SPI0_SIN	USB0_SOF_ OUT	I2S0_RX_FS	FB_AD8/ SDRAM_A16			
113	A8	PTC8	ADC1_SE4b/ CMP0_IN2	ADC1_SE4b/ CMP0_IN2	PTC8		FTM3_CH4	I2S0_MCLK	FB_AD7/ SDRAM_A15			
114	D7	PTC9	ADC1_SE5b/ CMP0_IN3	ADC1_SE5b/ CMP0_IN3	PTC9		FTM3_CH5	I2S0_RX_ BCLK	FB_AD6/ SDRAM_A14	FTM2_FLT0		
115	C7	PTC10	ADC1_SE6b	ADC1_SE6b	PTC10	I2C1_SCL	FTM3_CH6	I2S0_RX_FS	FB_AD5/ SDRAM_A13			
116	B7	PTC11/ LLWU_P11	ADC1_SE7b	ADC1_SE7b	PTC11/ LLWU_P11	I2C1_SDA	FTM3_CH7	I2S0_RXD1	FB_RW_b			
117	A7	PTC12	DISABLED		PTC12		UART4_ RTS_b	FTM_CLKIN0	FB_AD27/ SDRAM_D27	FTM3_FLT0	TPM_ CLKIN0	
118	D6	PTC13	DISABLED		PTC13		UART4_ CTS_b	FTM_CLKIN1	FB_AD26/ SDRAM_D26		TPM_ CLKIN1	
119	C6	PTC14	DISABLED		PTC14		UART4_RX		FB_AD25/ SDRAM_D25			
120	B6	PTC15	DISABLED		PTC15		UART4_TX		FB_AD24/ SDRAM_D24			
121	—	VSS	VSS	VSS								
122	—	VDD	VDD	VDD								
123	A6	PTC16	DISABLED		PTC16	CAN1_RX	UART3_RX	ENET0_ 1588_TMR0	FB_CS5_b/ FB_TSI21/ FB_BE23_ 16_BLS15_ 8_b/ SDRAM_ DQM2			
124	D5	PTC17	DISABLED		PTC17	CAN1_TX	UART3_TX	ENET0_ 1588_TMR1	FB_CS4_b/ FB_TSI20/			

Pinout

144 LQFP	144 MAP BGA	Pin Name	Default	ALT0	ALT1	ALT2	ALT3	ALT4	ALT5	ALT6	ALT7	EzPort
									FB_BE31_24_BLS7_0_b/ SDRAM_DQM3			
125	C5	PTC18	DISABLED		PTC18		UART3_RTS_b	ENET0_1588_TMR2	FB_TBST_b/ FB_CS2_b/ FB_BE15_8_BLS23_16_b/ SDRAM_DQM1			
126	B5	PTC19	DISABLED		PTC19		UART3_CTS_b	ENET0_1588_TMR3	FB_CS3_b/ FB_BE7_0_BLS31_24_b/ SDRAM_DQM0	FB_TA_b		
127	A5	PTD0/ LLWU_P12	DISABLED		PTD0/ LLWU_P12	SPI0_PCS0	UART2_RTS_b	FTM3_CH0	FB_ALE/ FB_CS1_b/ FB_TS_b			
128	D4	PTD1	ADC0_SE5b	ADC0_SE5b	PTD1	SPI0_SCK	UART2_CTS_b	FTM3_CH1	FB_CS0_b			
129	C4	PTD2/ LLWU_P13	DISABLED		PTD2/ LLWU_P13	SPI0_SOUT	UART2_RX	FTM3_CH2	FB_AD4/ SDRAM_A12		I2C0_SCL	
130	B4	PTD3	DISABLED		PTD3	SPI0_SIN	UART2_TX	FTM3_CH3	FB_AD3/ SDRAM_A11		I2C0_SDA	
131	A4	PTD4/ LLWU_P14	DISABLED		PTD4/ LLWU_P14	SPI0_PCS1	UART0_RTS_b	FTM0_CH4	FB_AD2/ SDRAM_A10	EWM_IN	SPI1_PCS0	
132	A3	PTD5	ADC0_SE6b	ADC0_SE6b	PTD5	SPI0_PCS2	UART0_CTS_b/ UART0_COL_b	FTM0_CH5	FB_AD1/ SDRAM_A9	EWM_OUT_b	SPI1_SCK	
133	A2	PTD6/ LLWU_P15	ADC0_SE7b	ADC0_SE7b	PTD6/ LLWU_P15	SPI0_PCS3	UART0_RX	FTM0_CH6	FB_AD0	FTM0_FLT0	SPI1_SOUT	
134	M10	VSS	VSS	VSS								
135	F8	VDD	VDD	VDD								
136	A1	PTD7	DISABLED		PTD7	CMT_IRO	UART0_TX	FTM0_CH7	SDRAM_CKE	FTM0_FLT1	SPI1_SIN	
137	C9	PTD8/ LLWU_P24	DISABLED		PTD8/ LLWU_P24	I2C0_SCL			LPUART0_RX	FB_A16		
138	B9	PTD9	DISABLED		PTD9	I2C0_SDA			LPUART0_TX	FB_A17		
139	B3	PTD10	DISABLED		PTD10				LPUART0_RTS_b	FB_A18		
140	B2	PTD11/ LLWU_P25	DISABLED		PTD11/ LLWU_P25	SPI2_PCS0		SDHC0_CLKIN	LPUART0_CTS_b	FB_A19		
141	B1	PTD12	DISABLED		PTD12	SPI2_SCK	FTM3_FLT0	SDHC0_D4		FB_A20		
142	C3	PTD13	DISABLED		PTD13	SPI2_SOUT		SDHC0_D5		FB_A21		

144 LQFP	144 MAP BGA	Pin Name	Default	ALT0	ALT1	ALT2	ALT3	ALT4	ALT5	ALT6	ALT7	EzPort
143	C2	PTD14	DISABLED		PTD14	SPI2_SIN		SDHC0_D6		FB_A22		
144	C1	PTD15	DISABLED		PTD15	SPI2_PCS1		SDHC0_D7		FB_A23		

5.2 Recommended connection for unused analog and digital pins

Table 62 shows the recommended connections for analog interface pins if those analog interfaces are not used in the customer's application

Table 62. Recommended connection for unused analog interfaces

Pin Type	K66	Short recommendation	Detailed recommendation
Analog/non GPIO	ADCx/CMPx	Float	Analog input - Float
Analog/non GPIO	VREF_OUT	Float	Analog output - Float
Analog/non GPIO	DAC0_OUT, DAC1_OUT	Float	Analog output - Float
Analog/non GPIO	RTC_WAKEUP_B	Float	Analog output - Float
Analog/non GPIO	XTAL32	Float	Analog output - Float
Analog/non GPIO	EXTAL32	Float	Analog input - Float
GPIO/Analog	PTA18/EXTAL0	Float	Analog input - Float
GPIO/Analog	PTA19/XTAL0	Float	Analog output - Float
GPIO/Analog	PTx/ADCx	Float	Float (default is analog input)
GPIO/Analog	PTx/CMPx	Float	Float (default is analog input)
GPIO/Analog	PTx/TSIOx	Float	Float (default is analog input)
GPIO/Digital	PTA0/JTAG_TCLK	Float	Float (default is JTAG with pulldown)
GPIO/Digital	PTA1/JTAG_TDI	Float	Float (default is JTAG with pullup)
GPIO/Digital	PTA2/JTAG_TDO	Float	Float (default is JTAG with pullup)
GPIO/Digital	PTA3/JTAG_TMS	Float	Float (default is JTAG with pullup)
GPIO/Digital	PTA4/NMI_b	10k Ω pullup or disable and float	Pull high or disable in PCR & FOPT and float
GPIO/Digital	PTx	Float	Float (default is disabled)
USB	USB0_DP	Float	Float
USB	USB0_DM	Float	Float
USB	VREG_OUT	Tie to input and ground through 10k Ω	Tie to input and ground through 10k Ω
USB	VREG_IN0	Tie to output and ground through 10k Ω	Tie to output and ground through 10k Ω

Table continues on the next page...

Table 62. Recommended connection for unused analog interfaces (continued)

Pin Type	K66	Short recommendation	Detailed recommendation
USB	VREG_IN1	Tie to output and ground through 10k Ω	Tie to output and ground through 10k Ω
USB	USB1_VSS	Always connect to VSS	Always connect to VSS
USB	USB1_DP	Float	Float
USB	USB1_DM	Float	Float
USB	USB1_VBUS	Float	Float
VBAT	VBAT	Float	Float
VDDA	VDDA	Always connect to VDD potential	Always connect to VDD potential
VREFH	VREFH	Always connect to VDD potential	Always connect to VDD potential
VREFL	VREFL	Always connect to VSS potential	Always connect to VSS potential
VSSA	VSSA	Always connect to VSS potential	Always connect to VSS potential

5.3 K66 Pinouts

The below figure shows the pinout diagram for the devices supported by this document. Many signals may be multiplexed onto a single pin. To determine what signals can be used on which pin, see the previous section.

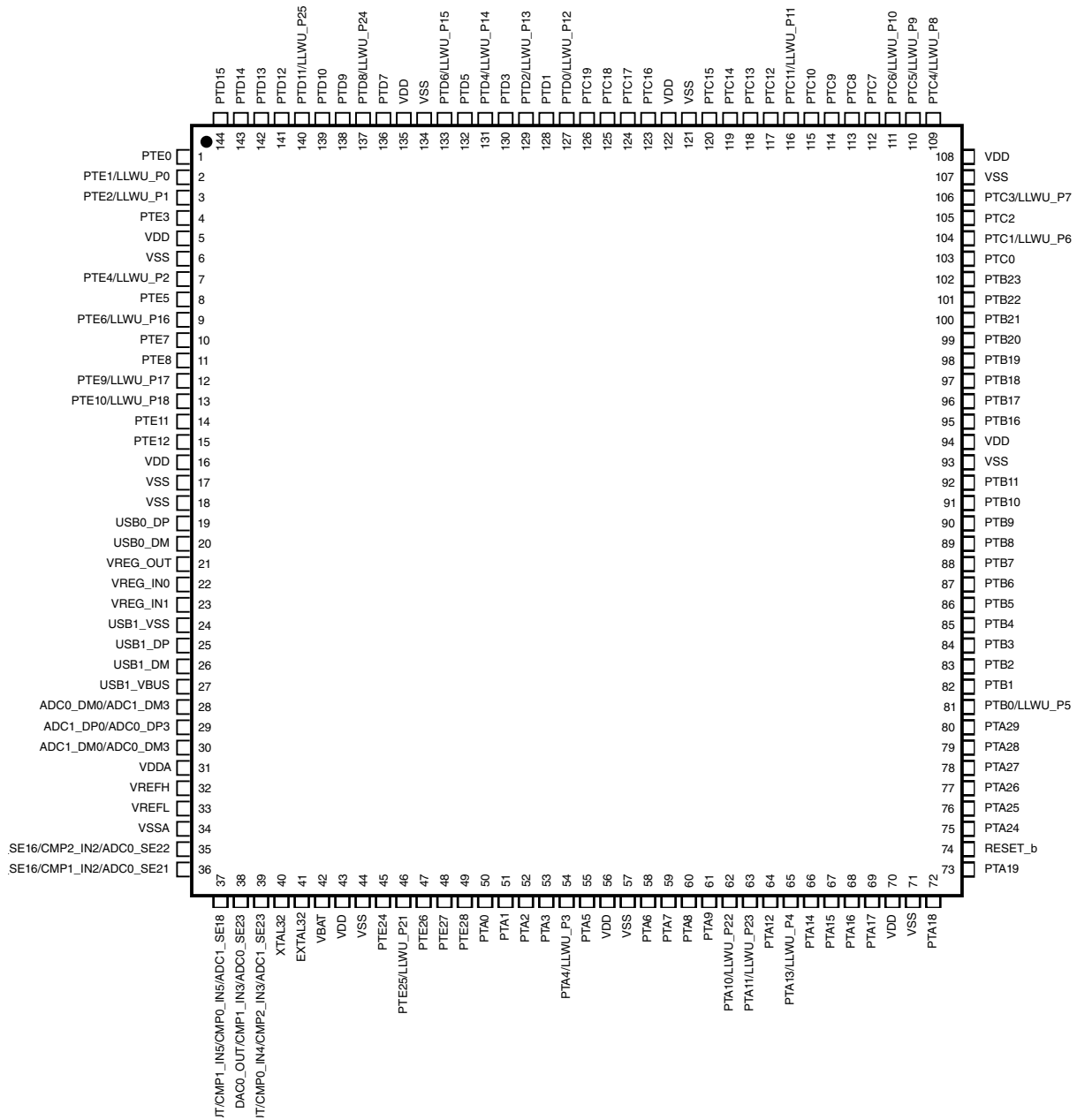

Figure 39. K66 144 LQFP Pinout Diagram

Ordering parts

	1	2	3	4	5	6	7	8	9	10	11	12	
A	PTD7	PTD6/ LLWU_P15	PTD5	PTD4/ LLWU_P14	PTD0/ LLWU_P12	PTC16	PTC12	PTC8	PTC4/ LLWU_P8	NC	PTC3/ LLWU_P7	PTC2	A
B	PTD12	PTD11/ LLWU_P25	PTD10	PTD3	PTC19	PTC15	PTC11/ LLWU_P11	PTC7	PTD9	NC	PTC1/ LLWU_P6	PTC0	B
C	PTD15	PTD14	PTD13	PTD2/ LLWU_P13	PTC18	PTC14	PTC10	PTC6/ LLWU_P10	PTD8/ LLWU_P24	NC	PTB23	PTB22	C
D	PTE2/ LLWU_P1	PTE1/ LLWU_P0	PTE0	PTD1	PTC17	PTC13	PTC9	PTC5/ LLWU_P9	PTB21	PTB20	PTB19	PTB18	D
E	PTE6/ LLWU_P16	PTE5	PTE4/ LLWU_P2	PTE3	VDD	VDD	VDD	VDD	PTB17	PTB16	PTB11	PTB10	E
F	PTE10/ LLWU_P18	PTE9/ LLWU_P17	PTE8	PTE7	VDD	VSS	VSS	VDD	PTB9	PTB8	PTB7	PTB6	F
G	VREG_OUT	VREG_IN0	PTE12	PTE11	VREFH	VREFL	VSS	VSS	PTB5	PTB4	PTB3	PTB2	G
H	USB0_DP	USB0_DM	VSS	PTE28	VDDA	VSSA	VSS	VSS	PTB1	PTB0/ LLWU_P5	PTA29	PTA28	H
J	USB1_DP	VREG_IN1	ADC0_SE16/ CMP1_IN2/ ADC0_SE21	PTE27	PTA0	PTA1	PTA6	PTA7	PTA13/ LLWU_P4	PTA27	PTA26	PTA25	J
K	USB1_DM	USB1_VSS	ADC1_SE16/ CMP2_IN2/ ADC0_SE22	PTE26	PTE25/ LLWU_P21	PTA2	PTA3	PTA8	PTA12	PTA16	PTA17	PTA24	K
L	USB1_VBUS	ADC0_DM0/ ADC1_DM3	DAC0_OUT/ CMP1_IN3/ ADC0_SE23	DAC1_OUT/ CMP0_IN4/ CMP2_IN3/ ADC1_SE23	RTC_ WAKEUP_B	VBAT	PTA4/ LLWU_P3	PTA9	PTA11/ LLWU_P23	PTA14	PTA15	RESET_b	L
M	ADC1_DP0/ ADC0_DP3	ADC1_DM0/ ADC0_DM3	VREF_OUT/ CMP1_IN5/ CMP0_IN5/ ADC1_SE18	PTE24	NC	EXTAL32	XTAL32	PTA5	PTA10/ LLWU_P22	VSS	PTA19	PTA18	M
	1	2	3	4	5	6	7	8	9	10	11	12	

Figure 40. K66 144 MAPBGA Pinout Diagram

6 Ordering parts

6.1 Determining valid orderable parts

Valid orderable part numbers are provided on the web. To determine the orderable part numbers for this device, go to nxp.com and perform a part number search for the following device numbers: PK66 and MK66

7 Part identification

7.1 Description

Part numbers for the chip have fields that identify the specific part. You can use the values of these fields to determine the specific part you have received.

7.2 Format

Part numbers for this device have the following format:

Q K## A M FFF R T PP CC N

7.3 Fields

This table lists the possible values for each field in the part number (not all combinations are valid):

Field	Description	Values
Q	Qualification status	<ul style="list-style-type: none"> M = Fully qualified, general market flow P = Prequalification
K##	Kinetis family	<ul style="list-style-type: none"> K65 K66
A	Key attribute	<ul style="list-style-type: none"> D = Cortex-M4 w/ DSP F = Cortex-M4 w/ DSP and FPU
M	Flash memory type	<ul style="list-style-type: none"> N = Program flash only X = Program flash and FlexMemory
FFF	Program flash memory size	<ul style="list-style-type: none"> 32 = 32 KB 64 = 64 KB 128 = 128 KB 256 = 256 KB 512 = 512 KB 768 = 768 KB

Table continues on the next page...

Terminology and guidelines

Field	Description	Values
		<ul style="list-style-type: none">• 1M0 = 1 MB• 2M0 = 2 MB
R	Silicon revision	<ul style="list-style-type: none">• Z = Initial• (Blank) = Main• A = Revision after main
T	Temperature range (°C)	<ul style="list-style-type: none">• V = -40 to 105• C = -40 to 85
PP	Package identifier	<ul style="list-style-type: none">• FM = 32 QFN (5 mm x 5 mm)• FT = 48 QFN (7 mm x 7 mm)• LF = 48 LQFP (7 mm x 7 mm)• LH = 64 LQFP (10 mm x 10 mm)• MP = 64 MAPBGA (5 mm x 5 mm)• LK = 80 LQFP (12 mm x 12 mm)• LL = 100 LQFP (14 mm x 14 mm)• MC = 121 MAPBGA (8 mm x 8 mm)• LQ = 144 LQFP (20 mm x 20 mm)• MD = 144 MAPBGA (13 mm x 13 mm)• MI = 169 MAPBGA (9 mm x 9 mm)• AC = 169 WLCSP (5.6 mm x 5.5 mm)
CC	Maximum CPU frequency (MHz)	<ul style="list-style-type: none">• 5 = 50 MHz• 7 = 72 MHz• 10 = 100 MHz• 12 = 120 MHz• 15 = 150 MHz• 16 = 168 MHz• 18 = 180 MHz
N	Packaging type	<ul style="list-style-type: none">• R = Tape and reel• (Blank) = Trays

7.4 Example

This is an example part number:

MK66FN2M0VMD18

8 Terminology and guidelines

8.1 Definitions

Key terms are defined in the following table:

Term	Definition
Rating	<p>A minimum or maximum value of a technical characteristic that, if exceeded, may cause permanent chip failure:</p> <ul style="list-style-type: none"> • <i>Operating ratings</i> apply during operation of the chip. • <i>Handling ratings</i> apply when the chip is not powered. <p>NOTE: The likelihood of permanent chip failure increases rapidly as soon as a characteristic begins to exceed one of its operating ratings.</p>
Operating requirement	A specified value or range of values for a technical characteristic that you must guarantee during operation to avoid incorrect operation and possibly decreasing the useful life of the chip
Operating behavior	A specified value or range of values for a technical characteristic that are guaranteed during operation if you meet the operating requirements and any other specified conditions
Typical value	<p>A specified value for a technical characteristic that:</p> <ul style="list-style-type: none"> • Lies within the range of values specified by the operating behavior • Is representative of that characteristic during operation when you meet the typical-value conditions or other specified conditions <p>NOTE: Typical values are provided as design guidelines and are neither tested nor guaranteed.</p>

8.2 Examples

Operating rating:

Symbol	Description	Min.	Max.	Unit
V _{DD}	1.0 V core supply voltage	-0.3	1.2	V

Operating requirement:

Symbol	Description	Min.	Max.	Unit
V _{DD}	1.0 V core supply voltage	0.9	1.1	V

Operating behavior that includes a typical value:

Symbol	Description	Min.	Typ.	Max.	Unit
I _{WP}	Digital I/O weak pullup/pulldown current	10	70	130	μA

8.3 Typical-value conditions

Typical values assume you meet the following conditions (or other conditions as specified):

Symbol	Description	Value	Unit
T _A	Ambient temperature	25	°C
V _{DD}	Supply voltage	3.3	V

8.4 Relationship between ratings and operating requirements

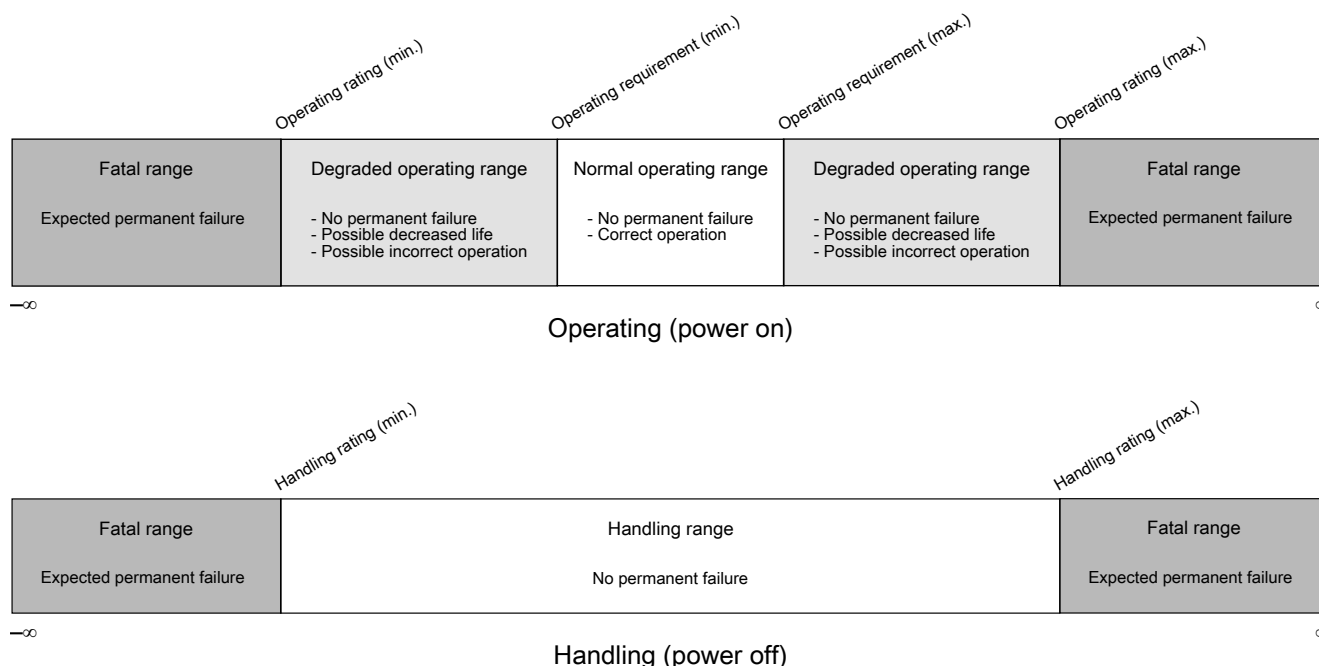

8.5 Guidelines for ratings and operating requirements

Follow these guidelines for ratings and operating requirements:

- Never exceed any of the chip’s ratings.
- During normal operation, don’t exceed any of the chip’s operating requirements.
- If you must exceed an operating requirement at times other than during normal operation (for example, during power sequencing), limit the duration as much as possible.

9 Revision History

The following table provides a revision history for this document.

Table 63. Revision History

Rev. No.	Date	Substantial Changes
0	02/2015	Initial Release
1	04/2015	<ul style="list-style-type: none"> • Editorial change • Updated OTG/EH and BC rev. 1.2 specification references in USB Full Speed Transceiver and High Speed PHY specifications section • Updated USBDCD electrical specifications table • Updated the typical values and maximum values of specs in Power consumption operating behaviors table • Removed PSTOP2 current from Power consumption operating behaviors table • Updated the values of DS5 and DS7 in Master mode DSPI timing (full voltage range) table • Updated the footnote and description of V_{DIO}, V_{AIO} and I_D in Voltage and current operating ratings table • Updated the values and description of specs in Voltage and current operating requirements table • Updated the leakage current specs in Voltage and current operating behaviors table • Added Notes column in Thermal operating requirements • Updated the values of 48MHz IRC in Low power mode peripheral adders table • Added new footnotes for I_{INRUSH} in USB VREG electrical specifications table to better document operation. • Updated the figures "SDRAM write timing diagram" and SDRAM read timing diagram" in the section "SDRAM controller specifications." • Updated the pinout table, and pinout diagrams in the section "Pinouts."
2	05/2015	<ul style="list-style-type: none"> • Added new footnotes for I_{INRUSH} in USB VREG electrical specifications table to better document operation. • Updated the figures "SDRAM write timing diagram" and SDRAM read timing diagram" in the section "SDRAM controller specifications." • Updated the pinout table, and pinout diagrams in the section "Pinouts."
3	01/2016	<ul style="list-style-type: none"> • Updated the symbol in footnote of Thermal Operating specs • Updated the description of PLL operating current in MCG specifications table • Updated the values of IRC48M specifications table • Added USB FS and USB HS logo in front page • Updated Terminology and guidelines section • Updated the maximum values of I_{DD_LLS2} and I_{DD_LLS3} in Power consumption operating behaviors table
4	03/2017	<ul style="list-style-type: none"> • Removed the verbiage of "except RTC_WAKEUP pins" from the description for R_{PU} and R_{PD} in Voltage and current operating behaviors table • Updated the unit of ADC conversion rate from "Kbps" to "kS/s" in 16-bit ADC operating conditions table • Added MII signal switching specifications table and RMII signal switching specifications table for full voltage range • Added MDIO serial management timing specifications section • Updated I2C switching specifications section • Updated the minimum and maximum value of Voltage reference output with factory trim in VREF full-range operating requirements table in Voltage reference electrical specifications section

Revision History

How to Reach Us:

Home Page:

nxp.com

Web Support:

nxp.com/support

Information in this document is provided solely to enable system and software implementers to use NXP products. There are no express or implied copyright licenses granted hereunder to design or fabricate any integrated circuits based on the information in this document. NXP reserves the right to make changes without further notice to any products herein.

NXP makes no warranty, representation, or guarantee regarding the suitability of its products for any particular purpose, nor does NXP assume any liability arising out of the application or use of any product or circuit, and specifically disclaims any and all liability, including without limitation consequential or incidental damages. "Typical" parameters that may be provided in NXP data sheets and/or specifications can and do vary in different applications, and actual performance may vary over time. All operating parameters, including "typicals," must be validated for each customer application by customer's technical experts. NXP does not convey any license under its patent rights nor the rights of others. NXP sells products pursuant to standard terms and conditions of sale, which can be found at the following address: nxp.com/SalesTermsandConditions.

NXP, the NXP logo, NXP SECURE CONNECTIONS FOR A SMARTER WORLD, Freescale, the Freescale logo, and Kinetis are trademarks of NXP B.V. All other product or service names are the property of their respective owners. ARM, the ARM powered logo, and Cortex are registered trademarks of ARM Limited (or its subsidiaries) in the EU and/or elsewhere. The USB-IF Logo is a registered trademark of USB Implementers Forum, Inc. All rights reserved.

© 2013–2017 NXP B.V.

Document Number K66P144M180SF5V2
Revision 4, 04/2017



Компания «Океан Электроники» предлагает заключение долгосрочных отношений при поставках импортных электронных компонентов на взаимовыгодных условиях!

Наши преимущества:

- Поставка оригинальных импортных электронных компонентов напрямую с производств Америки, Европы и Азии, а так же с крупнейших складов мира;
- Широкая линейка поставок активных и пассивных импортных электронных компонентов (более 30 млн. наименований);
- Поставка сложных, дефицитных, либо снятых с производства позиций;
- Оперативные сроки поставки под заказ (от 5 рабочих дней);
- Экспресс доставка в любую точку России;
- Помощь Конструкторского Отдела и консультации квалифицированных инженеров;
- Техническая поддержка проекта, помощь в подборе аналогов, поставка прототипов;
- Поставка электронных компонентов под контролем ВП;
- Система менеджмента качества сертифицирована по Международному стандарту ISO 9001;
- При необходимости вся продукция военного и аэрокосмического назначения проходит испытания и сертификацию в лаборатории (по согласованию с заказчиком);
- Поставка специализированных компонентов военного и аэрокосмического уровня качества (Xilinx, Altera, Analog Devices, Intersil, Interpoint, Microsemi, Actel, Aeroflex, Peregrine, VPT, Syfer, Eurofarad, Texas Instruments, MS Kennedy, Miteq, Cobham, E2V, MA-COM, Hittite, Mini-Circuits, General Dynamics и др.);

Компания «Океан Электроники» является официальным дистрибьютором и эксклюзивным представителем в России одного из крупнейших производителей разъемов военного и аэрокосмического назначения «**JONHON**», а так же официальным дистрибьютором и эксклюзивным представителем в России производителя высокотехнологичных и надежных решений для передачи СВЧ сигналов «**FORSTAR**».



JONHON

«**JONHON**» (основан в 1970 г.)

Разъемы специального, военного и аэрокосмического назначения:

(Применяются в военной, авиационной, аэрокосмической, морской, железнодорожной, горно- и нефтедобывающей отраслях промышленности)

«**FORSTAR**» (основан в 1998 г.)

ВЧ соединители, коаксиальные кабели,
кабельные сборки и микроволновые компоненты:

(Применяются в телекоммуникациях гражданского и специального назначения, в средствах связи, РЛС, а так же военной, авиационной и аэрокосмической отраслях промышленности).



Телефон: 8 (812) 309-75-97 (многоканальный)

Факс: 8 (812) 320-03-32

Электронная почта: ocean@oceanchips.ru

Web: <http://oceanchips.ru/>

Адрес: 198099, г. Санкт-Петербург, ул. Калинина, д. 2, корп. 4, лит. А