

High-Voltage, 350mA, Adjustable Linear High-Brightness LED Driver

General Description

The MAX16835 current regulator operates from a 6.5V to 40V input voltage range and delivers up to a total of 350mA to one or more strings of high-brightness LEDs (HB LEDs). The output current of the MAX16835 is adjusted by using an external current-sense resistor in series with the LEDs. An enable input allows wide-range “pulsed” dimming. Wave-shaping circuitry reduces EMI. The differential current-sense input increases noise immunity. The MAX16835 is well suited for applications requiring high-voltage input and is able to withstand automotive load-dump events up to 40V. An on-board pass element minimizes external components while providing $\pm 3.5\%$ output current accuracy. Additional features include a 5V regulated output and short-circuit and thermal protection.

The MAX16835 is available in a thermally enhanced, 5mm x 5mm, 16-pin TQFN package and is specified over the automotive -40°C to $+125^{\circ}\text{C}$ temperature range.

Applications

Automotive Interior: Map, Courtesy, and Cluster Lighting
 Automotive Exterior: Tail Lights and CHMSL
 Warning Lights for Emergency Vehicles
 Navigation and Marine Indicators
 General Illumination
 Signage, Gasoline Canopies, Beacons

Pin Configuration

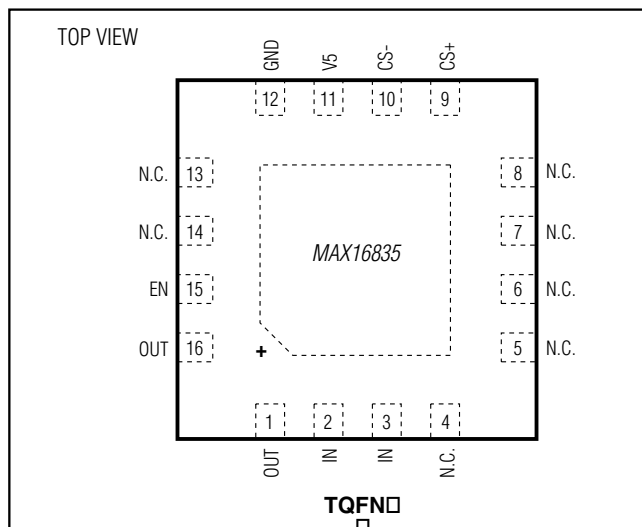

Features

- ◆ +6.5V to +40V Operating Range
- ◆ Adjustable LED Current (35mA to 350mA)
- ◆ $\pm 3.5\%$ Output Current Accuracy
- ◆ Integrated Pass Element with Low-Dropout Voltage (0.55V typ)
- ◆ Output Short-Circuit Protection
- ◆ +5V Regulated Output with 4mA Source Capability
- ◆ Thermal Shutdown
- ◆ Differential LED Current Sense
- ◆ High-Voltage Enable Pin for Dimming Interface
- ◆ Low Shutdown Supply Current (35 μA typ)
- ◆ Low 200mV Current-Sense Reference Reduces Power Losses
- ◆ Wave-Shaped Edges Reduce Radiated EMI During PWM Dimming
- ◆ Available in Small, Thermally Enhanced, 5mm x 5mm, 16-Pin TQFN Package
- ◆ -40°C to $+125^{\circ}\text{C}$ Operating Temperature Range

Ordering Information

PART	TEMP RANGE	PIN-PACKAGE
MAX16835ATE+	-40°C to $+125^{\circ}\text{C}$	16 TQFN-EP*
MAX16835ATE/V+	-40°C to $+125^{\circ}\text{C}$	16 TQFN-EP*

+ Denotes a lead(Pb)-free/RoHS-compliant package.

*EP = Exposed pad.

V denotes an automotive qualified part.

Simplified Diagram

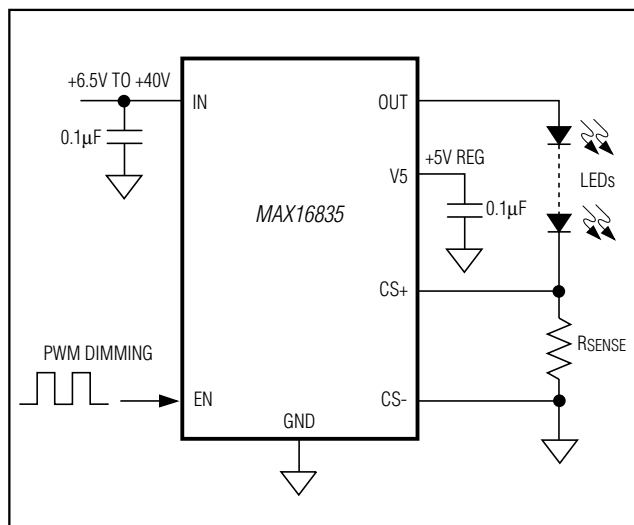

MAX16835

High-Voltage, 350mA, Adjustable Linear High-Brightness LED Driver

ABSOLUTE MAXIMUM RATINGS

IN to GND-0.3V to +45V
 OUT, EN to GND.....-0.3V to (VIN + 0.3V)
 CS+, CS-, and V5 to GND-0.3V to +6V
 OUT Short Circuited to GND Duration
 (at VIN = +16V)60 minutes
 Maximum Current into Any Pin (except IN and OUT)±20mA
 Continuous Power Dissipation (TA = +70°C)
 16-Pin TQFN 5mm x 5mm
 (derate 33.3mW/°C above +70°C).....2666.7mW

Operating Junction Temperature Range-40°C to +125°C
 Junction Temperature+150°C
 Storage Temperature Range-65°C to +150°C
 Lead Temperature (soldering, 10s)+300°C

Stresses beyond those listed under "Absolute Maximum Ratings" may cause permanent damage to the device. These are stress ratings only, and functional operation of the device at these or any other conditions beyond those indicated in the operational sections of the specifications is not implied. Exposure to absolute maximum rating conditions for extended periods may affect device reliability.

PACKAGE THERMAL CHARACTERISTICS (Note 1)

Junction-to-Ambient Thermal Resistance (θJA)30°C/W
 Junction-to-Case Thermal Resistance (θJC).....2°C/W

Note 1: Package thermal resistances obtained using the method described in JEDEC specification JESD51-7, using a four-layer board. For detailed information on package thermal considerations, see www.maximintegrated.com/thermal-tutorial.

ELECTRICAL CHARACTERISTICS

(VIN = VEN = +12V, CV5 = 0.1µF to GND, IV5 = 0, CS- = GND, connect RSENSE = 0.58Ω between CS+ and CS-. TA = -40°C to +125°C, unless otherwise noted. Typical values are at TA = +25°C.) (Notes 2 and 3)

PARAMETER	SYMBOL	CONDITIONS	MIN	TYP	MAX	UNITS
Supply Voltage Range	VIN	(Note 2)	6.5		40.0	V
Ground Current	IG	ILOAD = 350mA		1.28	3	mA
Shutdown Supply Current	ISHDN	VEN ≤ 0.6V		35	70	µA
Guaranteed Output Current	IOUT	RSENSE = 0.55Ω	350			mA
Output Current Accuracy		35mA < IOUT < 350mA		±3.5		%
Dropout Voltage (Note 4)	ΔVDO	IOUT = 350mA (current pulsed), 12V < VIN < 40V		0.55	1.2	V
		IOUT = 350mA (current pulsed), 6.5V < VIN < 40V		0.55	1.5	V
Output Current Slew Rate		Current rising		7.8		mA/µs
		Current falling		7.8		
Short-Circuit Current		VIN = 12V, VCS+ = 0V	400	500	650	mA
LOGIC INPUT						
EN Input Current	IEN		-2.5	-1.0	-0.2	µA
EN Input Voltage High	VIH		2.8			V
EN Input Voltage Low	VIL				0.6	V
Turn-On Time	ton	VEN rising edge to 90% of OUT		110	350	µs
CURRENT SENSE						
Regulated RSENSE Voltage	VSENSE	VSENSE = VCS+ - VCS-	193	200	207	mV
Input Current (CS+)		VCS+ = 220mV		2.7	7.0	µA
Input Current (CS-)		VCS+ = 220mV	-50	-17.2		µA

MAX16835

High-Voltage, 350mA, Adjustable Linear High-Brightness LED Driver

ELECTRICAL CHARACTERISTICS (continued)

($V_{IN} = V_{EN} = +12V$, $C_{V5} = 0.1\mu F$ to GND, $I_{V5} = 0$, $CS^- = GND$, connect $R_{SENSE} = 0.58\Omega$ between CS^+ and CS^- . $T_A = -40^\circ C$ to $+125^\circ C$, unless otherwise noted. Typical values are at $T_A = +25^\circ C$.) (Notes 2 and 3)

PARAMETER	SYMBOL	CONDITIONS	MIN	TYP	MAX	UNITS
THERMAL OVERLOAD						
Thermal-Shutdown Temperature				+159		$^\circ C$
Thermal-Shutdown Hysteresis				24		$^\circ C$
+5V REGULATOR						
Output Voltage	V_{V5}		4.85	5.00	5.20	V
Output Voltage Load Regulation	ΔV_{V5}	$0 < I_{LOAD} < 4mA$ (Note 5)		12	20	mV/mA
V5 Short-Circuit Current		$V5 = 0V$ (Note 6)		15		mA

Note 2: Resistors were added from OUT to CS^+ to aid with the power dissipation during testing.

Note 3: All devices 100% production tested at $T_A = +25^\circ C$. Limits over the operating temperature range are guaranteed by design.

Note 4: Dropout is measured as follows:

Connect $R_O = 27\Omega$ from OUT to CS^+ . Connect $R_{SENSE} = 0.58\Omega$ from CS^+ to CS^- . Set $V_{IN} = +12V$ (record V_{OUT} as V_{OUT1}).

Reduce V_{IN} until $V_{OUT} = 0.97 \times V_{OUT1}$ (record as V_{IN2} and V_{OUT2}). $\Delta V_{DO} = V_{IN2} - V_{OUT2}$.

Note 5: Current regulation varies with V5 load (see the *Typical Operating Characteristics*).

Note 6: Thermal shutdown does not function if the output of the 5V reference is shorted to ground.

Typical Operating Characteristics

($V_{IN} = V_{EN} = +12V$, $T_A = +25^\circ C$, unless otherwise noted.)

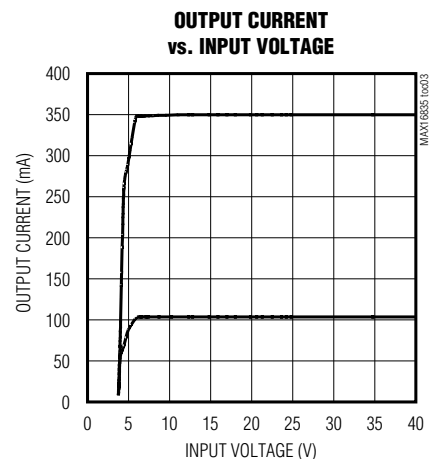
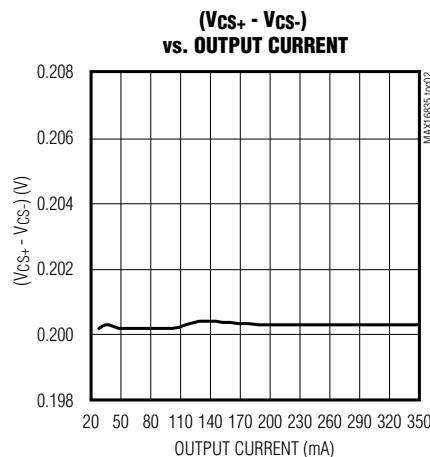
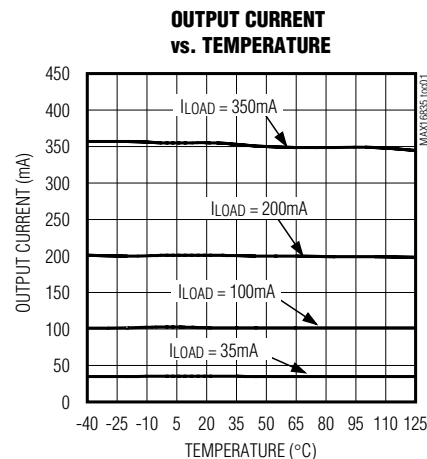

MAX16835

High-Voltage, 350mA, Adjustable Linear High-Brightness LED Driver

Typical Operating Characteristics (continued)

($V_{IN} = V_{EN} = +12V$, $T_A = +25^\circ C$, unless otherwise noted.)

DROPOUT VOLTAGE vs. TEMPERATURE

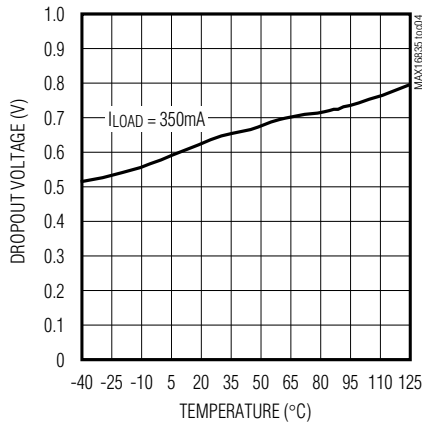

SHUTDOWN CURRENT vs. TEMPERATURE

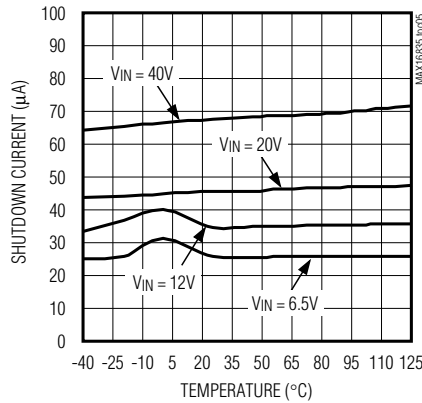

+5V REGULATOR OUTPUT vs. TEMPERATURE

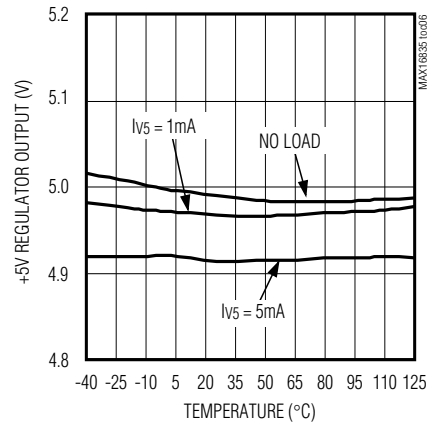

($V_{CS+} - V_{CS-}$) vs. I_{V5}

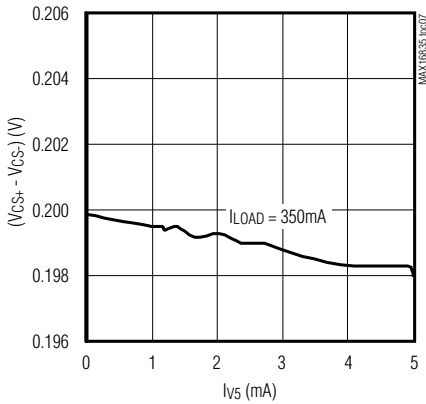

+5V REGULATOR OUTPUT vs. V_{IN}

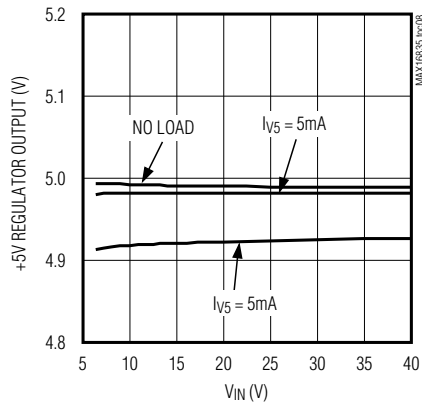

200Hz DIMMED OPERATION

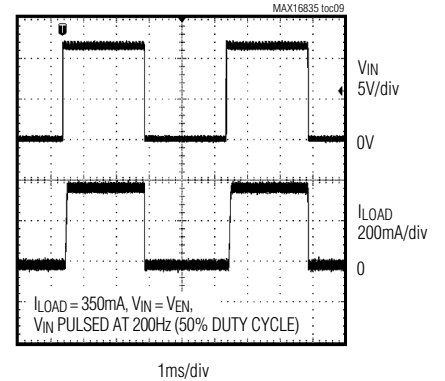

200Hz DIMMED OPERATION EXPANDED

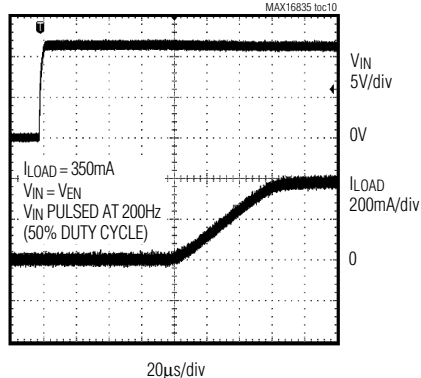

200Hz DIMMED OPERATION EXPANDED

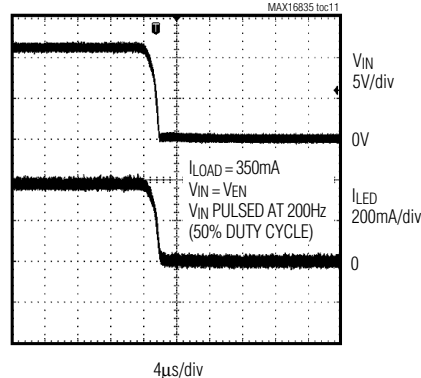

200Hz DIMMED OPERATION

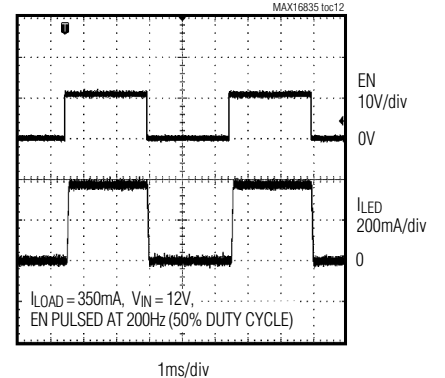

MAX16835

High-Voltage, 350mA, Adjustable Linear High-Brightness LED Driver

Pin Description

PIN	NAME	FUNCTION
1, 16	OUT	Current-Regulated Output. Connect pin 1 to pin 16.
2, 3	IN	Positive Input Supply. Bypass IN with a 0.1 μ F (min) capacitor to GND. Connect pin 2 to pin 3.
4–8, 13, 14	N.C.	No Connection. Not internally connected.
9	CS+	Positive Input of the Internal Differential Amplifier. Connect the current-sense resistor between CS+ and CS- to program the output current level.
10	CS-	Negative Input of the Internal Differential Amplifier. Connect the current-sense resistor between CS- and CS+ to program the output current level.
11	V5	+5V Regulated Output. Connect a 0.1 μ F capacitor from V5 to GND.
12	GND	Ground
15	EN	Enable Input. Drive EN high to enable the output.
—	EP	Exposed Pad. Connect to the ground plane for effective power dissipation. Do not use as the only ground connection.

Functional Diagram

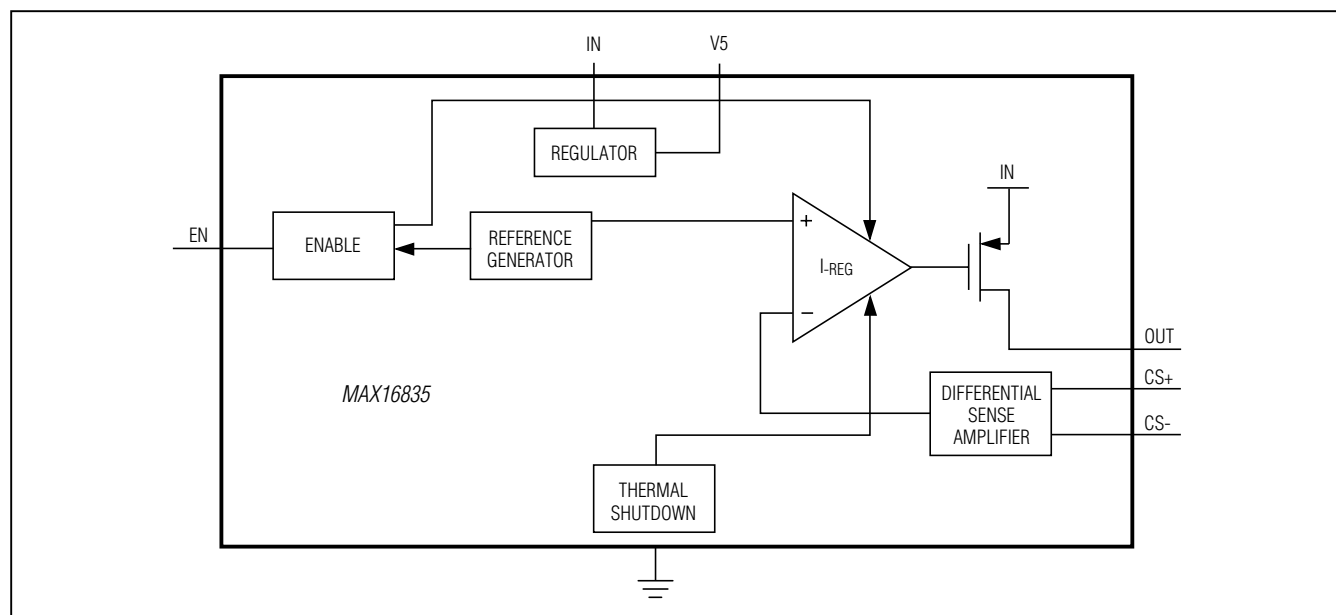

Detailed Description

The MAX16835 is a high-current regulator capable of providing up to a total of 350mA of current to one or more strings of high-brightness LEDs. A wide operating input voltage range of +6.5V to +40V makes the MAX16835 ideal for automotive applications. A +5V regulated output provides up to 4mA of current to power external circuitry. In addition, the MAX16835

features thermal and output short-circuit protection. The wide operating voltage range helps protect the MAX16835 against large transients such as those found in load-dump situations up to 40V.

The MAX16835 uses a feedback loop to control the output current. The differential voltage across the sense resistor is compared to a fixed reference voltage, and the error is amplified to serve as the drive to the internal

MAX16835

High-Voltage, 350mA, Adjustable Linear High-Brightness LED Driver

power series pass device (see the *Functional Diagram*). The regulation point is factory set at $(V_{CS+} - V_{CS-}) = 200\text{mV} \pm 3.5\%$. The regulated current is user defined by the value of R_{SENSE} .

The MAX16835 is a current controller internally optimized for driving the impedance range expected from one or more HB LEDs.

+5V Regulator

The MAX16835 includes a fixed +5V output regulator that delivers up to 4mA of load current for low-power applications throughout the +6.5V to +40V input voltage range. Connect a 0.1 μF compensation capacitor from V5 to ground. Shorting V5 to ground disables the thermal shutdown. When EN is low, V5 is off.

Thermal Protection

The MAX16835 enters a thermal-shutdown mode in the event of overheating. This typically occurs in overload or output short-circuit conditions. When the junction temperature exceeds $T_J = +159^\circ\text{C}$ (typ), the internal thermal-protection circuitry turns off the series pass device. The MAX16835 recovers from thermal-shutdown mode once the junction temperature drops by 24°C (typ). The part therefore protects itself by thermally cycling in the event of a short-circuit or overload condition. Shorting V5 to ground disables the thermal shutdown.

Applications Information

Programming the LED Current

The MAX16835 uses a sense resistor across CS+ and CS- to set the LED current. The differential sense amplifier

connected across R_{SENSE} provides ground-loop immunity and low-frequency noise rejection. The LED current is given by the equation below:

$$I_{LED} = V_{SENSE}/R_{SENSE}$$

Input Voltage Considerations

For proper operation, the minimum input voltage must always be:

$$V_{IN(MIN)} \geq V_{SENSE(MAX)} + V_{FT(MAX)} + \Delta V_{DO(MAX)}$$

where $V_{FT(MAX)}$ is the total forward voltage of all series-connected LEDs. The minimum operating voltage of the device is +6.5V. The device operates below +6.5V; However, the output current may not meet the full regulation specification.

Low-Frequency PWM at the Output

The MAX16835 provides pulsed or chopped current dimming. Generally, HB LEDs are binned to match at their full-rated current; however, LEDs from the same bin exhibit poor matching at currents other than full-rated current. To achieve uniformity, HB LED manufacturers recommend PWM pulsing of the LED current at their full-rated value. There are two methods for producing a PWM output. One method is by pulsing the enable input (EN) while having a constant voltage at IN. The other method is to connect EN to IN and pulse both EN and IN. Both methods generate a regulated-amplitude PWM current (variable duty cycle) that can provide control over the LED brightness (see Figures 1 and 2).

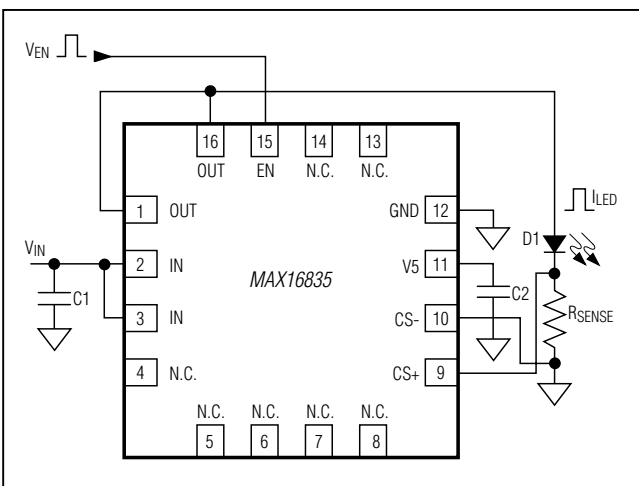

Figure 1. Pulse Application with V_{IN} at a Constant Voltage

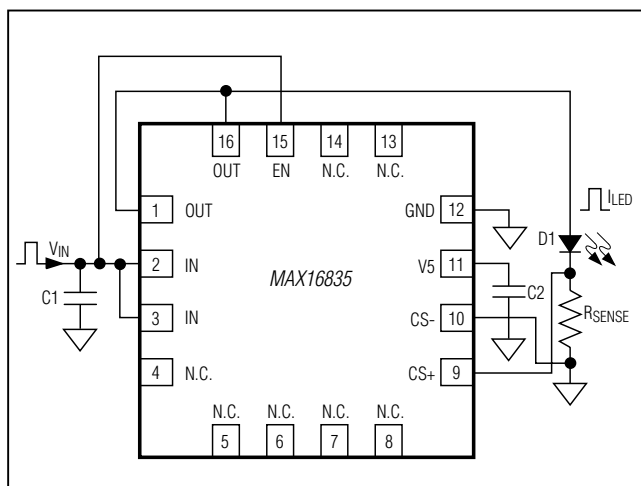
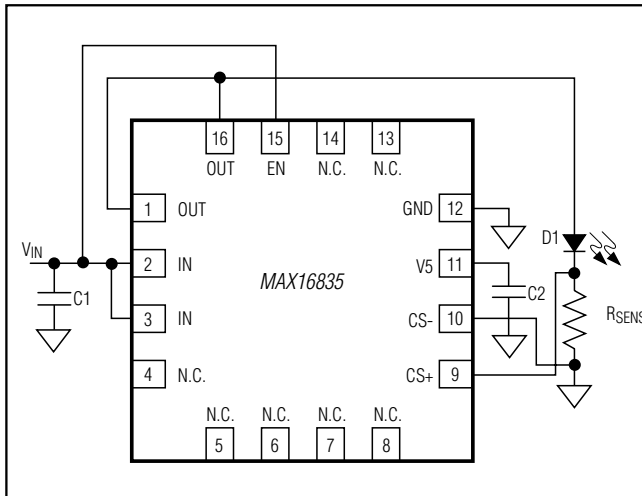

Figure 2. Pulse Application with EN Connected to V_{IN}

MAX16835

High-Voltage, 350mA, Adjustable Linear High-Brightness LED Driver

Typical Operating Circuit



Chip Information

PROCESS: BICMOS

Package Information

For the latest package outline information and land patterns (footprints), go to www.maximintegrated.com/packages. Note that a "+", "#", or "-" in the package code indicates RoHS status only. Package drawings may show a different suffix character, but the drawing pertains to the package regardless of RoHS status.

PACKAGE TYPE	PACKAGE CODE	OUTLINE NO.	LAND PATTERN NO.
16 TQFN	T1655+3	21-0140	90-0073

MAX16835

High-Voltage, 350mA, Adjustable Linear High-Brightness LED Driver

Revision History

REVISION NUMBER	REVISION DATE	DESCRIPTION	PAGES CHANGED
0	2/08	Initial release	—
1	5/08	Updated <i>Ordering Information</i> , <i>Electrical Characteristics</i> , and <i>Package Information</i> .	1, 2, 8, 9
2	10/12	Added automotive qualified part to <i>Ordering Information</i>	1



Maxim Integrated cannot assume responsibility for use of any circuitry other than circuitry entirely embodied in a Maxim Integrated product. No circuit patent licenses are implied. Maxim Integrated reserves the right to change the circuitry and specifications without notice at any time. The parametric values (min and max limits) shown in the Electrical Characteristics table are guaranteed. Other parametric values quoted in this data sheet are provided for guidance.

Компания «Океан Электроники» предлагает заключение долгосрочных отношений при поставках импортных электронных компонентов на взаимовыгодных условиях!

Наши преимущества:

- Поставка оригинальных импортных электронных компонентов напрямую с производств Америки, Европы и Азии, а так же с крупнейших складов мира;
- Широкая линейка поставок активных и пассивных импортных электронных компонентов (более 30 млн. наименований);
- Поставка сложных, дефицитных, либо снятых с производства позиций;
- Оперативные сроки поставки под заказ (от 5 рабочих дней);
- Экспресс доставка в любую точку России;
- Помощь Конструкторского Отдела и консультации квалифицированных инженеров;
- Техническая поддержка проекта, помощь в подборе аналогов, поставка прототипов;
- Поставка электронных компонентов под контролем ВП;
- Система менеджмента качества сертифицирована по Международному стандарту ISO 9001;
- При необходимости вся продукция военного и аэрокосмического назначения проходит испытания и сертификацию в лаборатории (по согласованию с заказчиком);
- Поставка специализированных компонентов военного и аэрокосмического уровня качества (Xilinx, Altera, Analog Devices, Intersil, Interpoint, Microsemi, Actel, Aeroflex, Peregrine, VPT, Syfer, Eurofarad, Texas Instruments, MS Kennedy, Miteq, Cobham, E2V, MA-COM, Hittite, Mini-Circuits, General Dynamics и др.);

Компания «Океан Электроники» является официальным дистрибьютором и эксклюзивным представителем в России одного из крупнейших производителей разъемов военного и аэрокосмического назначения «JONHON», а так же официальным дистрибьютором и эксклюзивным представителем в России производителя высокотехнологичных и надежных решений для передачи СВЧ сигналов «FORSTAR».



JONHON

«JONHON» (основан в 1970 г.)

Разъемы специального, военного и аэрокосмического назначения:

(Применяются в военной, авиационной, аэрокосмической, морской, железнодорожной, горно- и нефтедобывающей отраслях промышленности)

«FORSTAR» (основан в 1998 г.)

ВЧ соединители, коаксиальные кабели, кабельные сборки и микроволновые компоненты:

(Применяются в телекоммуникациях гражданского и специального назначения, в средствах связи, РЛС, а так же военной, авиационной и аэрокосмической отраслях промышленности).



Телефон: 8 (812) 309-75-97 (многоканальный)

Факс: 8 (812) 320-03-32

Электронная почта: ocean@oceanchips.ru

Web: <http://oceanchips.ru/>

Адрес: 198099, г. Санкт-Петербург, ул. Калинина, д. 2, корп. 4, лит. А