

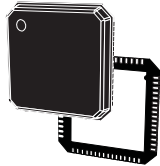

AM/FM/HD-Radio™ submicron technology automotive receiver

VFQFPN64 (9 x 9 x 1.0 mm)

Features

- AEC-Q100 qualified 
- AM/FM reception with digital IF processing
- Fully automotive grade CMOS design
- AM/FM Band
- Low-IF, DSP-based architecture
- Very high dynamic range built-in IF-ADC
- Minimum external component count
- Very small footprint package
- Multipath noise mitigation processing
- RDS demodulation with group and block synchronization
- Compatible with HD-Radio™ and DRM
- Digital Audio Output
- Fully RoHS-compliant

Description

The **TDA7708** is a single chip fully-CMOS AM/FM tuner aimed at receivers for terrestrial radio broadcasting.

The TDA7708 is a complete integrated and optimized RF tuner for AM/FM reception. It allows the implementation of AM/FM solution (and also HD-Radio™ with external STMicroelectronics's STA680 co-processor) for automotive grade receivers and other applications.

The TDA7708 combines state-of-art performance with minimum external component count, making it therefore ideal for integration into car radios and other radio devices with challenging performance, quality, reliability and, last but not least, cost requirements.

Such a low external component count is made possible by cutting-edge circuit and implementation techniques that overcome the major challenges affecting both very-low and zero IF receivers.

The TDA7708 features multiple front-end low-noise amplifiers (LNAs) to cover AM LW/MW/SW bands, and the entire FM band, with advanced automatic gain control (AGC) amplifier and mixer stages.

After on-chip IF filtering, the TDA7708 digitizes the signal with a very high dynamic range ADC; it processes the complex phase-quadrature baseband signal allowing applications like multipath noise mitigation, and integrated RDS decoding.

The TDA7708 furthermore integrates the HD-Radio™ channel filtering.

Besides providing optimal AM/FM quality reception, the TDA7708 makes it the ideal solution to realize a complete HD-Radio™ receiver solution (in combination with the external STA680 HD-Radio™ decoder) or a DRM receiver (paired to the STA660DRM), with a low bill of material, high performance and real automotive grade quality and reliability.

Product status	
TDA7708	

Device summary		
Order code	Package	Packing
TDA7708	VFQFPN64 (9 x 9 x 1 mm)	Tray
TDA7708CB		Tape & Reel
TDA7708TR		
TDA7708CBTR		

The TDA7708CB requires a very small FW code to be downloaded for booting the IC, thus making it especially suited to systems whose microcontroller has limited code storage capability.

1 Block diagram

Figure 1. Block diagram

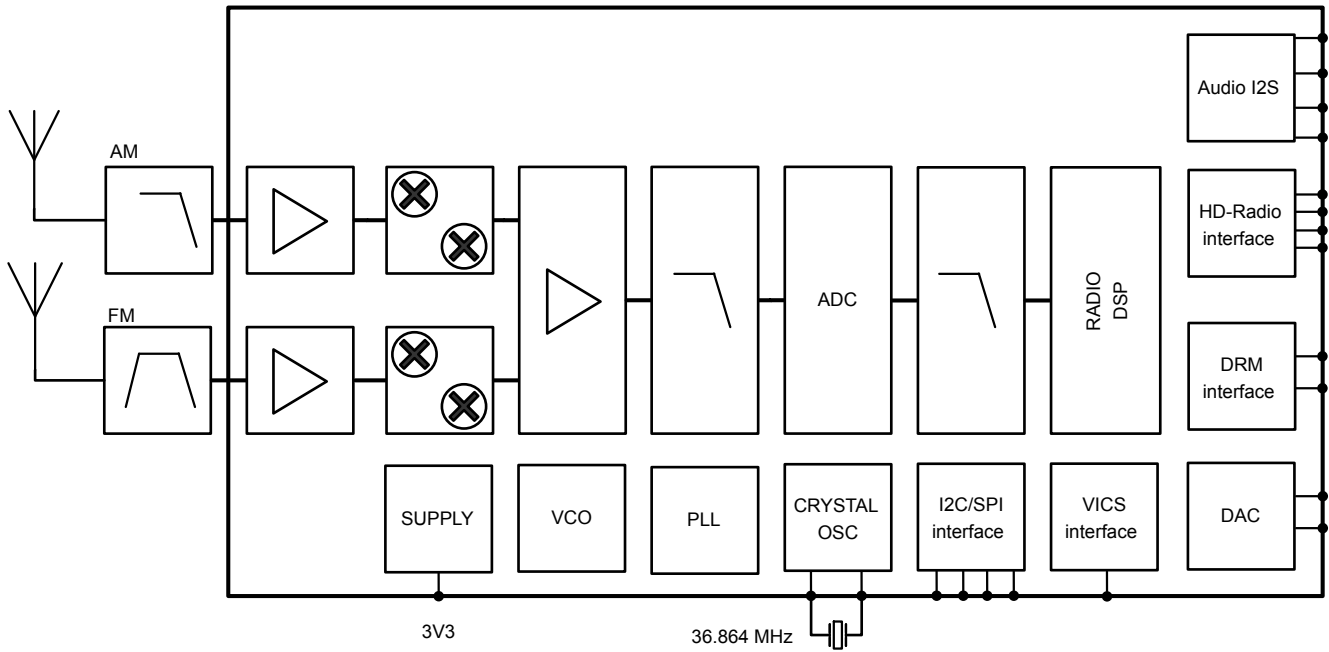

2 Electrical specification

2.1 Absolute maximum ratings

Table 1. Absolute maximum ratings

Symbol	Parameter	Test condition	Min	Typ	Max	Units
V _{CC}	Abs. supply voltage	-	-0.5	-	3.6	V
T _{stg}	Storage temperature	-	-55	-	150	°C
V _{ESD}	ESD absolute minimum withstand voltage	Human Body model	> ±2000 ⁽¹⁾			V
		Charged device model	> ±500 ⁽²⁾			
		Charged device model, corner pins	> ±750			
-	Max. input current at any pin (latch-up characteristic)	I _{INMAX}	±100			mA

1. |±1000| on AM_IN pin

2. |±400| on AM_IN pin

2.2 Thermal data

Table 2. Thermal data

Symbol	Parameter	Test condition	Value	Units
R _{th j-amb}	Thermal resistance junction-to-ambient	Multilayer 2s2p as per JEDEC JESD51-7	27	°C/W

2.3 General key parameters

Table 3. General key parameters

Symbol	Parameter	Test condition	Min	Typ	Max	Units
V _{CC}	3.3 V supply voltage	-	3.15	3.3	3.45	V
I _{CC}	Supply current	FM @108 MHz, active interfaces (10 pF load)	-	-	350	mA
T _{amb}	Ambient temperature range	-	-40	-	85	°C
T _{j_oper}	Operative junction temp	-	-	-	125	°C
P _{diss}	Dissipated power	R _{ext} = 12 Ohm	-	-	1	W

3 Package information

In order to meet environmental requirements, ST offers these devices in different grades of **ECOPACK** packages, depending on their level of environmental compliance. ECOPACK specifications, grade definitions and product status are available at: www.st.com. ECOPACK is an ST trademark.

3.1 VFQFPN-64 (9x9x1.0mm) package information

Figure 2. VFQFPN-64 (9x9x1.0 mm) package outline

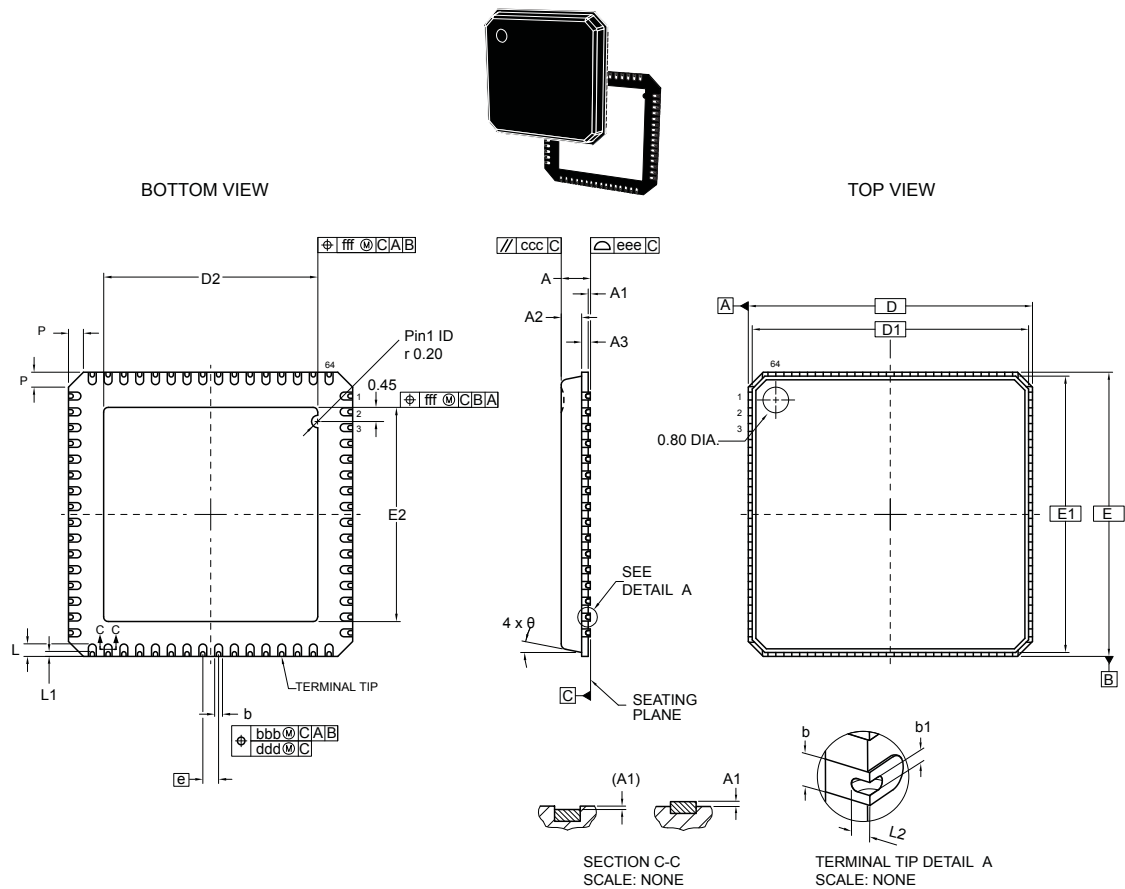

8511068_B_A02G

GAPGPS03460

Table 4. VFQFPN-64 (9x9x1.0 mm) package mechanical data

Ref.	Dimensions in mm		
	Min.	Typ.	Max.
Θ	-	-	14
A	-	-	1.0
A1	0.00	-	0.05
A2	0.55	-	0.80
A3	0.20 REF		
b ⁽¹⁾	0.18	0.25	0.30

Ref.	Dimensions in mm		
	Min.	Typ.	Max.
b1	-	0.15	-
D	9.00 BSC		
D1 ⁽²⁾	8.75 BSC		
D2	-	6.70	-
e	0.50 BSC		
E	9.00 BSC		
E1 ⁽²⁾	8.75 BSC		
E2	-	6.70	-
L	0.30	-	0.50
L1	0.15 REF		
L2	-	0.10	-
P	-	-	0.60
Tolerance of form and position			
aaa	0.15		
bbb	0.10		
ccc	0.10		
ddd	0.05		
eee	0.08		
fff	0.10		

1. Maximum allowable burr is 0.076 mm in all directions.

2. D1 and E1 are Maximum plastic body size dimensions including mold mismatch. Dimensions D1 and E1 do not include mold flash or protrusions. Allowable mold flash or protrusions is "0.25 mm (0.0098 inch)" per side.

Note: The package is compliant to IPC/JEDEC J-STD-020D June 2007 standard Moisture/Reflow Sensitivity Classification for Nonhermetic Solid State Surface Mount Devices, MSL Level 3.

Revision history

Table 5. Document revision history

Date	Revision	Changes
16-Dec-2014	1	Initial release.
29-Nov-2016	2	Fully revised.
15-May-2017	3	Added 'RDS demodulation' on Section Features .
25-Jan-2018	4	Updated Section Description and Device summary table on cover page.
25-Nov-2019	5	Updated Figure 1. Block diagram .

IMPORTANT NOTICE – PLEASE READ CAREFULLY

STMicroelectronics NV and its subsidiaries (“ST”) reserve the right to make changes, corrections, enhancements, modifications, and improvements to ST products and/or to this document at any time without notice. Purchasers should obtain the latest relevant information on ST products before placing orders. ST products are sold pursuant to ST’s terms and conditions of sale in place at the time of order acknowledgement.

Purchasers are solely responsible for the choice, selection, and use of ST products and ST assumes no liability for application assistance or the design of Purchasers’ products.

No license, express or implied, to any intellectual property right is granted by ST herein.

Resale of ST products with provisions different from the information set forth herein shall void any warranty granted by ST for such product.

ST and the ST logo are trademarks of ST. For additional information about ST trademarks, please refer to www.st.com/trademarks. All other product or service names are the property of their respective owners.

Information in this document supersedes and replaces information previously supplied in any prior versions of this document.

© 2019 STMicroelectronics – All rights reserved

Компания «Океан Электроники» предлагает заключение долгосрочных отношений при поставках импортных электронных компонентов на взаимовыгодных условиях!

Наши преимущества:

- Поставка оригинальных импортных электронных компонентов напрямую с производств Америки, Европы и Азии, а так же с крупнейших складов мира;
- Широкая линейка поставок активных и пассивных импортных электронных компонентов (более 30 млн. наименований);
- Поставка сложных, дефицитных, либо снятых с производства позиций;
- Оперативные сроки поставки под заказ (от 5 рабочих дней);
- Экспресс доставка в любую точку России;
- Помощь Конструкторского Отдела и консультации квалифицированных инженеров;
- Техническая поддержка проекта, помощь в подборе аналогов, поставка прототипов;
- Поставка электронных компонентов под контролем ВП;
- Система менеджмента качества сертифицирована по Международному стандарту ISO 9001;
- При необходимости вся продукция военного и аэрокосмического назначения проходит испытания и сертификацию в лаборатории (по согласованию с заказчиком);
- Поставка специализированных компонентов военного и аэрокосмического уровня качества (Xilinx, Altera, Analog Devices, Intersil, Interpoint, Microsemi, Actel, Aeroflex, Peregrine, VPT, Syfer, Eurofarad, Texas Instruments, MS Kennedy, Miteq, Cobham, E2V, MA-COM, Hittite, Mini-Circuits, General Dynamics и др.);

Компания «Океан Электроники» является официальным дистрибьютором и эксклюзивным представителем в России одного из крупнейших производителей разъемов военного и аэрокосмического назначения «JONHON», а так же официальным дистрибьютором и эксклюзивным представителем в России производителя высокотехнологичных и надежных решений для передачи СВЧ сигналов «FORSTAR».



JONHON

«JONHON» (основан в 1970 г.)

Разъемы специального, военного и аэрокосмического назначения:

(Применяются в военной, авиационной, аэрокосмической, морской, железнодорожной, горно- и нефтедобывающей отраслях промышленности)

«FORSTAR» (основан в 1998 г.)

ВЧ соединители, коаксиальные кабели, кабельные сборки и микроволновые компоненты:

(Применяются в телекоммуникациях гражданского и специального назначения, в средствах связи, РЛС, а так же военной, авиационной и аэрокосмической отраслях промышленности).



Телефон: 8 (812) 309-75-97 (многоканальный)

Факс: 8 (812) 320-03-32

Электронная почта: ocean@oceanchips.ru

Web: <http://oceanchips.ru/>

Адрес: 198099, г. Санкт-Петербург, ул. Калинина, д. 2, корп. 4, лит. А