

DATA SHEET

SURFACE-MOUNT CERAMIC MULTILAYER CHIP VARISTORS

VR0402/0603/0805/1206

3.3 V TO 110 V

RoHS compliant & Halogen Free



SCOPE

This specification describes chip varistors with lead-free terminations.

APPLICATIONS

- Consumer electronic equipment
- Telecommunications
- Notebook
- Electronic data processing

FEATURES

- Excellent clamping voltage
- Excellent energy dissipation capability
- Quick response time (<1n sec.)
- Adjustable capacitance values
- High reliability
- High transient current capability
- Symmetrical voltage-current characteristics

ORDERING INFORMATION-GLOBAL PART NUMBER, PHYCOMP

CTC & I2NC

All part numbers are identified by the series, size, tolerance, TC material, packing style, voltage, process code, termination and capacitance value.

YAGEO BRAND ordering code

GLOBAL PART NUMBER (PREFERRED)

VRS XXXX X **R** XXX XXX X
 (1) (2) (3) (4) (5)

(1) SIZE – INCH BASED (METRIC)

- 0402 (1005)
- 0603 (1608)
- 0805 (2012)
- 1206 (3216)

(2) TOLERANCE

- K = ±10%
- L = ±15%
- M = ±20%
- S = Normal range

(3) WORKING VOLTAGE

2 significant digits+number of zeros
 The 3rd digit signifies the multiplying factor, and letter R is decimal point
 Example: 33R = 33 × 10⁻¹ = 3.3 V, 111 = 11 × 10¹ = 110 V

(4) CAPACITANCE VALUE

2 significant digits+number of zeros
 The 3rd digit signifies the multiplying factor, and letter R is decimal point
 Example: 121 = 12 × 10¹ = 120 pF

(5) PROCESS CODE

- N = Normal
- A = Automotive

CONSTRUCTION

- Lead Free terminations, NiSn terminations
- Surface mount multilayer surge suppressor
- Very short response time (<1.0 nsec)
- Bidirectional clamping
- Low capacitance for high frequency applications
- Very low leakage current

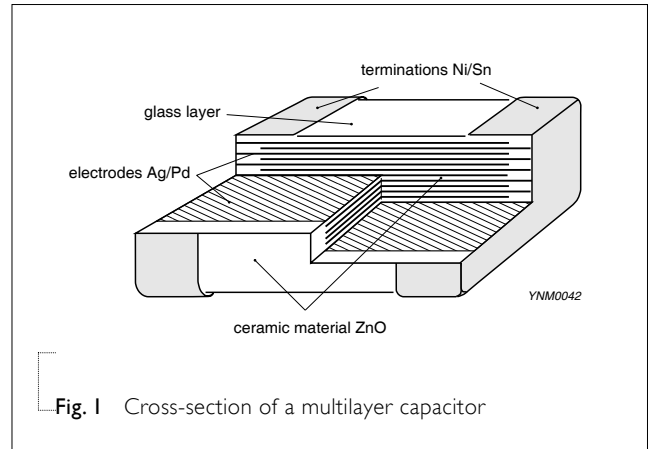

Fig. 1 Cross-section of a multilayer capacitor

DIMENSION

Table I For outlines see fig. 2

TYPE	L ₁ (mm)	W (mm)	T (MM)	L ₂ / L ₃ (mm)		L ₄ (mm)
				min.	max.	min.
0402	1.0 ±0.10	0.5 ±0.10	0.5 ±0.10	0.15	0.30	0.40
0603	1.6 ±0.20	0.8 ±0.10	0.8 ±0.10	0.20	0.60	0.40
0805	2.0 ±0.10	1.25 ±0.10	0.85 ±0.10	0.25	0.75	0.55
1206	3.2 ±0.15	1.6 ±0.15	0.85 ±0.10	0.25	0.75	1.40

OUTLINES

For dimension see Table I

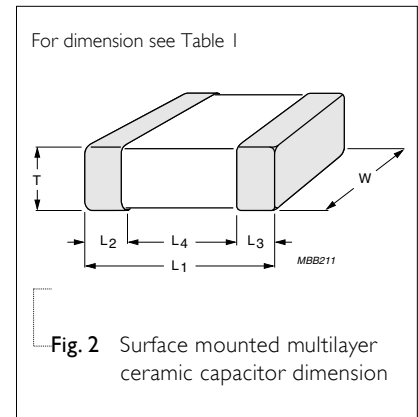

Fig. 2 Surface mounted multilayer ceramic capacitor dimension

ELECTRICAL CHARACTERISTICS
Table 2 Size 0402

PART NUMBER	VARISTOR/ BREAKDOWN VOL.	MAX. WORKING VOL.	CLAMPING VOL.@1A	PEAK CURRENT	LEAKAGE CURRENT R.T. (15~35 °C)		CAPACITANCE @ 1V (RMS)	
	DC @1mA	D.C (max.)	8/20 μS (max.)	8/20 μS (max.)	Voltage	Current	1KHz	1MHz
VRS0402SR55R220N	10 V ~ 14 V	5.5 V	22 V	2 A	3 V	3 μA	22 pF	12 pF
VRS0402SR55R330N	10 V ~ 14 V	5.5 V	22 V	4 A	3 V	3 μA	33 pF	20 pF
VRS0402SR55R500N	10 V ~ 14 V	5.5 V	22 V	6 A	3 V	3 μA	50 pF	30 pF
VRS0402SR55R101N	10 V ~ 14 V	5.5 V	22 V	10 A	3 V	3 μA	100 pF	60 pF
VRS0402MR55R101N	7.2 V ~ 10.8 V	5.5 V	15 V	10 A	3 V	3 μA	100 pF	60 pF
VRS0402MR55R201N	7.2 V ~ 10.8 V	5.5 V	15 V	15 A	3 V	3 μA	200 pF	130 pF
VRS0402MR55R361N	7.2 V ~ 10.8 V	5.5 V	15 V	20 A	3 V	3 μA	360 pF	220 pF
VRS0402MR55R481N	7.2 V ~ 10.8 V	5.5 V	15 V	20 A	3 V	3 μA	480 pF	290 pF
VRS0402MR55R651N	7.2 V ~ 10.8 V	5.5 V	14 V	30 A	3 V	3 μA	650 pF	390 pF
VRS0402KR090500N	10.8 V ~ 13.2 V	9 V	22 V	6 A	3 V	3 μA	50 pF	30 pF
VRS0402LR090201N	10.2 V ~ 13.8 V	9 V	22 V	15 A	3 V	3 μA	200 pF	120 pF
VRS0402SR140500N	18 V ~ 24 V	14 V	38 V	7 A	3 V	3 μA	50 pF	30 pF
VRS0402SR140101N	18 V ~ 24 V	14 V	38 V	15 A	3 V	3 μA	100 pF	60 pF
VRS0402SR140121N	18 V ~ 24 V	14 V	38 V	15 A	3 V	3 μA	120 pF	72 pF
VRS0402MR140161N	14.4 V ~ 21.6 V	14 V	35 V	20 A	3 V	3 μA	160 pF	96 pF
VRS0402KR140161N	16.2 V ~ 19.8 V	14 V	33 V	20 A	3 V	3 μA	160 pF	96 pF
VRS0402LR140251N	15.3 V ~ 20.7 V	14 V	33 V	20 A	3 V	3 μA	250 pF	150 pF
VRS0402SR180010N	90 V ~ 135 V	18 V	250 V	1 A	3 V	0.3 μA	---	1 pF
VRS0402SR180030N	50 V ~ 80 V	18 V	130 V	1 A	3 V	0.3 μA	3 pF	2 pF
VRS0402SR180050N	50 V ~ 80 V	18 V	130 V	2 A	3 V	0.3 μA	5 pF	3 pF
VRS0402SR180100N	24 V ~ 32 V	18 V	50 V	3 A	3 V	0.3 μA	10 pF	5.5 pF
VRS0402SR180150N	24 V ~ 32 V	18 V	50 V	3 A	3 V	0.3 μA	15 pF	9 pF
VRS0402SR180270N	24 V ~ 32 V	18 V	50 V	4 A	3 V	0.3 μA	27 pF	15 pF
VRS0402SR180400N	24 V ~ 32 V	18 V	50 V	4 A	3 V	0.3 μA	40 pF	22 pF
VRS0402SR180500N	24 V ~ 32 V	18 V	50 V	4 A	3 V	0.3 μA	50 pF	30 pF
VRS0402KR180820N	21.6 V ~ 26.4 V	18 V	45 V	10 A	3 V	0.3 μA	82 pF	50 pF
VRS0402SR180121N	24 V ~ 32 V	18 V	50 V	15 A	3 V	0.3 μA	120 pF	72 pF

ELECTRICAL CHARACTERISTICS

Table 3 Size 0603

PART NUMBER	VARISTOR/	MAX. WORKING	CLAMPING	PEAK	LEAKAGE CURRENT		CAPACITANCE	
	BREAKDOWN VOL.	VOL.	VOL.@1A	CURRENT	R.T. (15~35 °C)		@ IV (RMS)	
	DC @1mA	D.C (max.)	8/20 μS (max.)	8/20 μS (max.)	Voltage	Current	1KHz	1MHz
VRS0603MR33R152N	5 V ~ 7 V	3.3 V	12 V	30 A	3 V	5 μA	1,500 pF	900 pF
VRS0603SR55R181N	10 V ~ 14 V	5.5 V	20 V	20 A	3 V	3 μA	180 pF	100 pF
VRS0603MR55R301N	7.2 V ~ 10.8 V	5.5 V	15 V	30 A	3 V	3 μA	300 pF	180 pF
VRS0603MR55R361N	7.2 V ~ 10.8 V	5.5 V	15 V	30 A	3 V	3 μA	360 pF	180 pF
VRS0603SR55R471N	10 V ~ 14 V	5.5 V	19 V	30 A	3 V	3 μA	470 pF	280 pF
VRS0603MR55R681N	7.2 V ~ 10.8 V	5.5 V	15 V	30 A	3 V	3 μA	680 pF	410 pF
VRS0603MR55R751N	7.2 V ~ 10.8 V	5.5 V	15 V	30 A	3 V	3 μA	750 pF	450 pF
VRS0603MR55R901N	7.2 V ~ 10.8 V	5.5 V	15 V	30 A	3 V	3 μA	900 pF	540 pF
VRS0603SR090090N	18 V ~ 24 V	9 V	36 V	3 A	3 V	3 μA	9 pF	5.5 pF
VRS0603LR140361N	15.3 V ~ 20.7 V	14 V	33 V	30 A	3 V	3 μA	360 pF	216 pF
VRS0603SR180030N	50 V ~ 80 V	18 V	130 V	1 A	3 V	0.3 μA	3 pF	2 pF
VRS0603SR180050N	50 V ~ 80 V	18 V	130 V	2 A	3 V	0.3 μA	5 pF	3 pF
VRS0603SR180100N	24 V ~ 32 V	18 V	50 V	5 A	3 V	0.3 μA	10 pF	6 pF
VRS0603SR180150N	24 V ~ 32 V	18 V	50 V	3 A	3 V	0.3 μA	15 pF	10 pF
VRS0603SR180121N	24 V ~ 32 V	18 V	50 V	20 A	3 V	0.3 μA	120 pF	72 pF
VRS0603KR180151N	21.6 V ~ 26.4 V	18 V	44 V	20 A	3 V	0.3 μA	150 pF	90 pF
VRS0603KR180301N	21.6 V ~ 26.4 V	18 V	44 V	20 A	3 V	0.3 μA	300 pF	180 pF
VRS0603KR220241N	24.3 V ~ 29.7 V	22 V	46 V	20 A	3 V	0.3 μA	240 pF	144 pF
VRS0603KR260251N	29.7 V ~ 36.3 V	26 V	58 V	20 A	3 V	0.3 μA	250 pF	160 pF
VRS0603KR300121N	35.1 V ~ 42.9 V	30 V	70 V	20 A	3 V	0.3 μA	120 pF	72 pF
VRS0603KR310161N	35.1 V ~ 42.9 V	31 V	70 V	20 A	3 V	0.3 μA	160 pF	96 pF
VRS0603KR380101N	42.3 V ~ 51.7 V	38 V	85 V	15 A	3 V	0.3 μA	100 pF	60 pF
VRS0603KR450800N	50.4 V ~ 61.6 V	45 V	100 V	10 A	3 V	0.3 μA	80 pF	48 pF
VRS0603SR111300N	130 V ~ 160 V	110 V	300 V	5 A	3 V	0.3 μA	30 pF	18 pF

Table 4 Size 0805

PART NUMBER	VARISTOR/	MAX. WORKING	CLAMPING	PEAK	LEAKAGE CURRENT		CAPACITANCE	
	BREAKDOWN VOL.	VOL.	VOL.@1A	CURRENT	R.T. (15~35 °C)		@ IV (RMS)	
	DC @1mA	D.C (max.)	8/20 μS (max.)	8/20 μS (max.)	Voltage	Current	1KHz	1MHz
VRS0805MR55R112N	7.2 V ~ 10.8 V	5.5 V	18 V	40 A	1 V	35 μA	1,100 pF	660 pF
VRS0805MR55R302N	7.2 V ~ 10.8 V	5.5 V	17.5 V	120 A	1 V	35 μA	3,000 pF	1,800 pF
VRS0805MR55R701N	7.2 V ~ 10.8 V	5.5 V	17 V	30 A	1 V	10 μA	700 pF	420 pF
VRS0805LR120551N	13.6 V ~ 18.4 V	12 V	27 V	40 A	1 V	25 μA	550 pF	330 pF
VRS0805KR140601N	16.2 V ~ 19.8 V	14 V	29 V	40 A	1 V	15 μA	600 pF	360 pF
VRS0805KR180551N	21.6 V ~ 26.4 V	18 V	42 V	100 A	1 V	10 μA	550 pF	330 pF
VRS0805SR300161N	37 V ~ 46 V	30 V	72 V	30 A	1 V	10 μA	160 pF	96 pF
VRS0805KR380201N	42.3 V ~ 51.7 V	38 V	77 V	80 A	1 V	10 μA	200 pF	120 pF

ELECTRICAL CHARACTERISTICS

Table 5 Size 1206

PART NUMBER	VARISTOR/ BREAKDOWN VOL.	MAX. WORKING VOL.	CLAMPING VOL.@1A	PEAK CURRENT	LEAKAGE CURRENT R.T. (15~35 °C)		CAPACITANCE @ 1V (RMS)	
	DC @1mA	D.C (max.)	8/20 μS (max.)	8/20 μS (max.)	Voltage	Current	1KHz	1MHz
VRS1206MR180901N	19.2 V ~ 28.8 V	18 V	50 V	150 A	3 V	0.3 μA	900 pF	540 pF
VRS1206KR380501N	42.3 V ~ 51.7 V	38 V	77 V	180 A	3 V	0.3 μA	500 pF	300 pF
VRS1206SR420112N	46 V ~ 60 V	42 V	92 V	180 A	3 V	0.3 μA	1,100 pF	660 pF

STANDARD TESTING CONDITION

1. Temperature: 15 °C to 35 °C
2. Humidity: 25% RH to 85% RH
3. Atmospheric pressure: 86 to 106 kPa

ESD (ELECTROSTATIC DISCHARGE) TEST

ESD discharge circuit according to IEC 61000-4-2

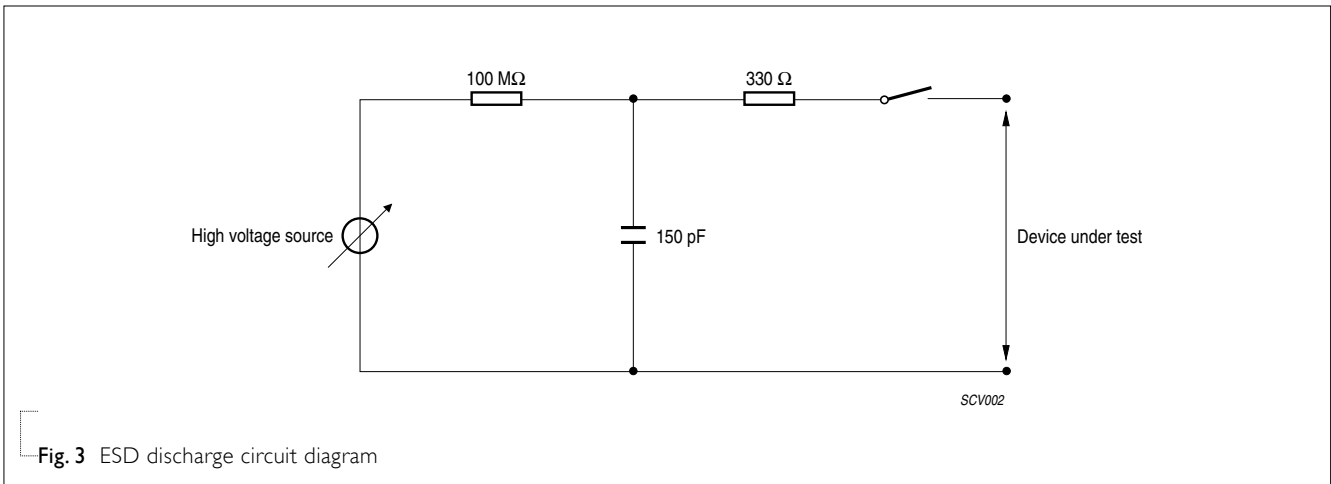

Fig. 3 ESD discharge circuit diagram

SPECIFICATION OF ELECTROSTATIC DISCHARGE (ESD) TEST:

According to standard EN 61000-4-2, up to 8 KV direct contact (contact discharge)

THICKNESS CLASSES AND PACKING QUANTITY

Table 6

SIZE CODE	THICKNESS CLASSIFICATION	TAPE WIDTH QUANTITY PER REEL	Ø180 MM / 7 INCH (PAPER)
0402	0.5 ±0.03 mm	8 mm	10,000
0603	0.8 ±0.1 mm	8 mm	4,000
0805	0.85 ±0.1 mm	8 mm	4,000
1206	0.85 ±0.1 mm	8 mm	4,000

METHOD OF MOUNTING

For normal use the varistor may be mounted on printed-circuit boards or ceramic substrates by applying wave soldering, reflow soldering (including vapour phase soldering) or conductive adhesive in accordance with CECC 00802 classification A. For advised soldering profiles see Figs 4, 5, and 6.

An improper combination of soldering, substrate and chip size can lead to a damaging of the component. The risk increases with the chip size and with temperature fluctuations (>100 °C). More detailed information is available on request.

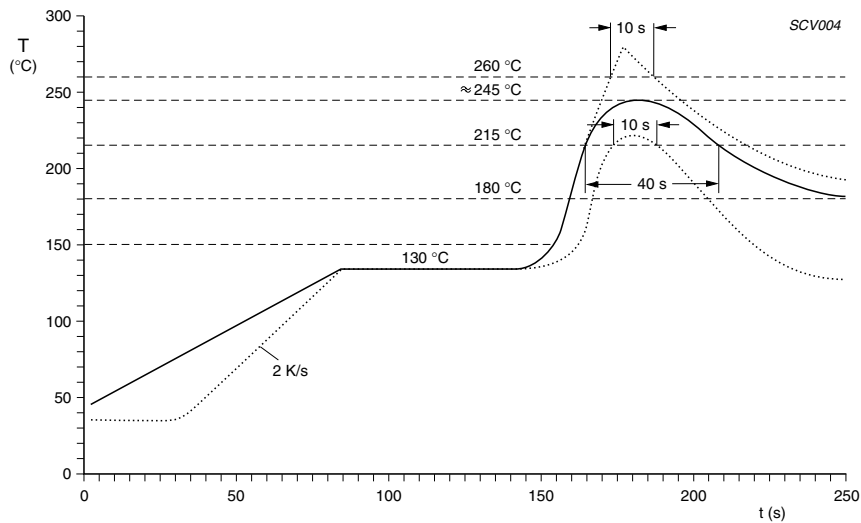

Fig. 4 Reflow soldering

Typical values (solid line) Process limits (dotted lines)

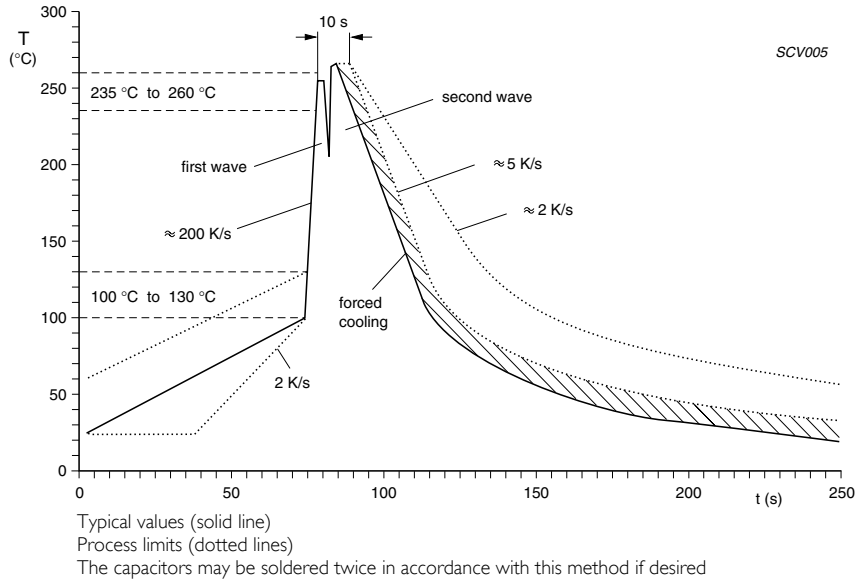

Fig. 5 Double wave soldering

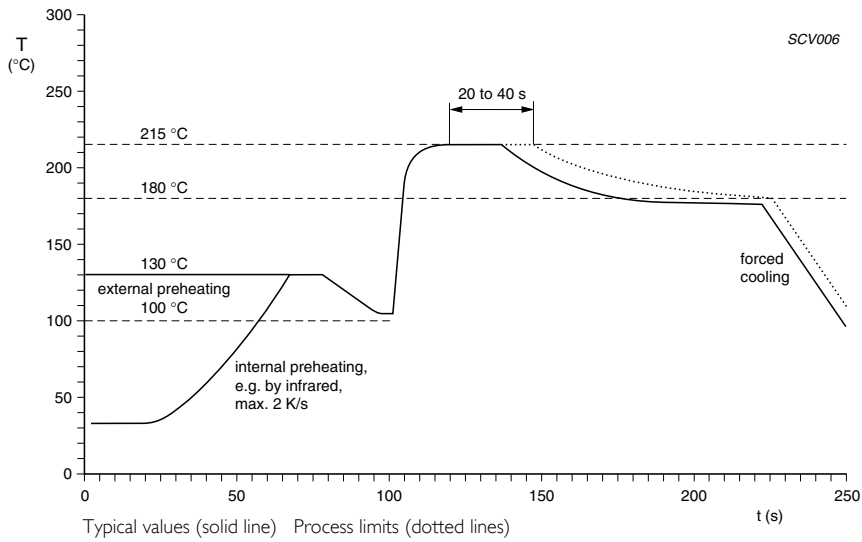

Fig. 6 Vapour phase soldering

TESTS AND REQUIREMENTS
Table 7 Test procedures and requirements

TEST	TEST METHOD		PROCEDURE	REQUIREMENTS
Capacitance	CECC4200 4.6	IEC1051 4.7	f = 1 KHz / 1 MHz Measuring voltage 1 Vrms at 25 °C	> 5 pF: ±30% at 1KHz 3 pF to 5 pF: +80% / -20% at 1KHz < 3 pF: +80% / -20% at 1MHz
Bond strength of plating on end face	4.9	4.10	To be soldered on the glass-epoxy (thickness 1.6 mm), the load shall be put on the board bends 1 mm	No visible damage
Solderability	4.10	4.11	Unmounted chips completely immersed for 2 ±0.5 seconds (dipping time) in a solder bath at 235 ±2 °C	The termination should be well tinned
Resistance to soldering heat	4.10.2	4.12	Solder bath temperature: 260 ±5 °C Dipping time: 10 ±0.5 seconds	Δ VImA / VImA <10%
Rapid change of temperature	4.12	4.13	5 cycles with following detail 30 minutes at -40°C 30 minutes at +85 °C	Δ VImA / VImA <10%
Damp heat with U _r load	4.17	4.18	Duration and conditions: 500 ±12 hours at 40 ±2 °C 90 to 95% RH; U _r applied	Δ VImA / VImA <10%
Endurance	4.19	4.20	Duration and conditions: 500 ±12 hours at 85 °C; U _r applied	Δ VImA / VImA <10%
Endurance at upper category temperature	4.20	4.20	Duration and conditions: 1,000 ±12 hours at 85 °C	Δ VImA / VImA <10%
Adhesion	IEC 60384-1 4.34		A force of 2N applied for 10 seconds to the line joining the terminations and in a plane parallel to the substrate	No visible damage
Cold temperature storae	4.25		Duration and conditions 1,000 ±12 hours at -40 ±2 °C	Δ VImA / VImA <10%

REVISION HISTORY

REVISION	DATE	CHANGE NOTIFICATION	DESCRIPTION
Version 1	Jul 22, 2010	-	- Dimension updated
Version 0	Jun 08, 2010	-	- New

Компания «Океан Электроники» предлагает заключение долгосрочных отношений при поставках импортных электронных компонентов на взаимовыгодных условиях!

Наши преимущества:

- Поставка оригинальных импортных электронных компонентов напрямую с производств Америки, Европы и Азии, а так же с крупнейших складов мира;
- Широкая линейка поставок активных и пассивных импортных электронных компонентов (более 30 млн. наименований);
- Поставка сложных, дефицитных, либо снятых с производства позиций;
- Оперативные сроки поставки под заказ (от 5 рабочих дней);
- Экспресс доставка в любую точку России;
- Помощь Конструкторского Отдела и консультации квалифицированных инженеров;
- Техническая поддержка проекта, помощь в подборе аналогов, поставка прототипов;
- Поставка электронных компонентов под контролем ВП;
- Система менеджмента качества сертифицирована по Международному стандарту ISO 9001;
- При необходимости вся продукция военного и аэрокосмического назначения проходит испытания и сертификацию в лаборатории (по согласованию с заказчиком);
- Поставка специализированных компонентов военного и аэрокосмического уровня качества (Xilinx, Altera, Analog Devices, Intersil, Interpoint, Microsemi, Actel, Aeroflex, Peregrine, VPT, Syfer, Eurofarad, Texas Instruments, MS Kennedy, Miteq, Cobham, E2V, MA-COM, Hittite, Mini-Circuits, General Dynamics и др.);

Компания «Океан Электроники» является официальным дистрибьютором и эксклюзивным представителем в России одного из крупнейших производителей разъемов военного и аэрокосмического назначения «JONHON», а так же официальным дистрибьютором и эксклюзивным представителем в России производителя высокотехнологичных и надежных решений для передачи СВЧ сигналов «FORSTAR».



JONHON

«JONHON» (основан в 1970 г.)

Разъемы специального, военного и аэрокосмического назначения:

(Применяются в военной, авиационной, аэрокосмической, морской, железнодорожной, горно- и нефтедобывающей отраслях промышленности)

«FORSTAR» (основан в 1998 г.)

ВЧ соединители, коаксиальные кабели, кабельные сборки и микроволновые компоненты:

(Применяются в телекоммуникациях гражданского и специального назначения, в средствах связи, РЛС, а так же военной, авиационной и аэрокосмической отраслях промышленности).



Телефон: 8 (812) 309-75-97 (многоканальный)

Факс: 8 (812) 320-03-32

Электронная почта: ocean@oceanchips.ru

Web: <http://oceanchips.ru/>

Адрес: 198099, г. Санкт-Петербург, ул. Калинина, д. 2, корп. 4, лит. А