



**MCP1601**  
**Evaluation Board (Rev. 1)**  
**User's Guide**

---

---

**Note the following details of the code protection feature on Microchip devices:**

- Microchip products meet the specification contained in their particular Microchip Data Sheet.
- Microchip believes that its family of products is one of the most secure families of its kind on the market today, when used in the intended manner and under normal conditions.
- There are dishonest and possibly illegal methods used to breach the code protection feature. All of these methods, to our knowledge, require using the Microchip products in a manner outside the operating specifications contained in Microchip's Data Sheets. Most likely, the person doing so is engaged in theft of intellectual property.
- Microchip is willing to work with the customer who is concerned about the integrity of their code.
- Neither Microchip nor any other semiconductor manufacturer can guarantee the security of their code. Code protection does not mean that we are guaranteeing the product as "unbreakable."

Code protection is constantly evolving. We at Microchip are committed to continuously improving the code protection features of our products. Attempts to break Microchip's code protection feature may be a violation of the Digital Millennium Copyright Act. If such acts allow unauthorized access to your software or other copyrighted work, you may have a right to sue for relief under that Act.

---

Information contained in this publication regarding device applications and the like is provided only for your convenience and may be superseded by updates. It is your responsibility to ensure that your application meets with your specifications. MICROCHIP MAKES NO REPRESENTATIONS OR WARRANTIES OF ANY KIND WHETHER EXPRESS OR IMPLIED, WRITTEN OR ORAL, STATUTORY OR OTHERWISE, RELATED TO THE INFORMATION, INCLUDING BUT NOT LIMITED TO ITS CONDITION, QUALITY, PERFORMANCE, MERCHANTABILITY OR FITNESS FOR PURPOSE. Microchip disclaims all liability arising from this information and its use. Use of Microchip's products as critical components in life support systems is not authorized except with express written approval by Microchip. No licenses are conveyed, implicitly or otherwise, under any Microchip intellectual property rights.

**Trademarks**

The Microchip name and logo, the Microchip logo, Accuron, dsPIC, KEELOQ, microID, MPLAB, PIC, PICmicro, PICSTART, PRO MATE, PowerSmart, rfPIC, and SmartShunt are registered trademarks of Microchip Technology Incorporated in the U.S.A. and other countries.

AmpLab, FilterLab, MXDEV, MXLAB, PICMASTER, SEEVAL, SmartSensor and The Embedded Control Solutions Company are registered trademarks of Microchip Technology Incorporated in the U.S.A.

Analog-for-the-Digital Age, Application Maestro, dsPICDEM, dsPICDEM.net, dsPICworks, ECAN, ECONOMONITOR, FanSense, FlexROM, fuzzyLAB, In-Circuit Serial Programming, ICSP, ICEPIC, Migratable Memory, MPASM, MPLIB, MPLINK, MPSIM, PICKit, PICDEM, PICDEM.net, PICLAB, PICtail, PowerCal, PowerInfo, PowerMate, PowerTool, rLAB, rfPICDEM, Select Mode, Smart Serial, SmartTel and Total Endurance are trademarks of Microchip Technology Incorporated in the U.S.A. and other countries.

SQTP is a service mark of Microchip Technology Incorporated in the U.S.A.

All other trademarks mentioned herein are property of their respective companies.

© 2004, Microchip Technology Incorporated, Printed in the U.S.A., All Rights Reserved.

 Printed on recycled paper.

**QUALITY MANAGEMENT SYSTEM**  
**CERTIFIED BY DNV**  
**== ISO/TS 16949:2002 ==**

*Microchip received ISO/TS-16949:2002 quality system certification for its worldwide headquarters, design and wafer fabrication facilities in Chandler and Tempe, Arizona and Mountain View, California in October 2003. The Company's quality system processes and procedures are for its PICmicro® 8-bit MCUs, KEELOQ® code hopping devices, Serial EEPROMs, microperipherals, nonvolatile memory and analog products. In addition, Microchip's quality system for the design and manufacture of development systems is ISO 9001:2000 certified.*



# MCP1601 Evaluation Board (Rev. 1) User Guide

---

---

## Table of Contents

---

---

<b>Preface</b> .....	<b>1</b>
<b>Chapter 1. Product Overview</b> .....	<b>5</b>
1.1 Introduction .....	5
1.2 What is the MCP1601 Evaluation Board (Rev. 1)? .....	6
1.3 What the MCP1601 Evaluation Board (Rev. 1) kit includes .....	6
<b>Chapter 2. MCP1601 Evaluation Board (Rev. 1)</b> .....	<b>7</b>
2.1 Introduction .....	7
2.2 Features .....	7
2.3 Getting Started .....	7
2.4 Test Points .....	9
<b>Appendix A. Schematic and Layouts</b> .....	<b>11</b>
A.1 Introduction .....	11
A.2 Board Schematic .....	12
A.3 Board - Top Layer .....	13
A.4 Board - Bottom Layer .....	14
<b>Appendix B. Bill-Of-Materials (BOM)</b> .....	<b>15</b>
<b>Worldwide Sales and Service</b> .....	<b>16</b>

# MCP1601 Evaluation Board (Rev. 1) User Guide

---

---

NOTES:

---

---

## Preface

---

---

### NOTICE TO CUSTOMERS

All documentation becomes dated, and this manual is no exception. Microchip tools and documentation are constantly evolving to meet customer needs, so some actual dialogs and/or tool descriptions may differ from those in this document. Please refer to our web site ([www.microchip.com](http://www.microchip.com)) to obtain the latest documentation available.

Documents are identified with a “DS” number. This number is located on the bottom of each page, in front of the page number. The numbering convention for the DS number is “DSXXXXA”, where “XXXX” is the document number and “A” is the revision level of the document.

For the most up-to-date information on development tools, see the MPLAB® IDE on-line help. Select the Help menu, and then Topics to open a list of available on-line help files.

## INTRODUCTION

This chapter contains general information that will be useful to know before using the MCP1601 Evaluation Board (Rev. 1). Items discussed in this chapter include:

- About This Guide
- Recommended Reading
- The Microchip Web Site
- Customer Support

## ABOUT THIS GUIDE

### Document Layout

This document describes how to use MCP1601 Evaluation Board (Rev. 1) as a development tool to emulate and debug firmware on a target board. The manual layout is as follows:

- **Chapter 1: Product Overview** – Important information about the MCP1601 Evaluation Board (Rev. 1).
- **Chapter 2: MCP1601 Evaluation Board (Rev. 1)** – Includes instructions on how to get started, as well as a description of the evaluation board.
- **Appendix A: Schematic and Layouts** – Shows the schematic and layout diagrams for the MCP1601 Evaluation Board (Rev. 1).
- **Appendix B: Bill-of-Materials** – Lists the parts used to build the MCP1601 Evaluation Board (Rev. 1).

# MCP1601 Evaluation Board (Rev. 1) User's Guide

## Conventions Used in this Guide

This manual uses the following documentation conventions:

### DOCUMENTATION CONVENTIONS

Description	Represents	Examples
<b>Arial font:</b>		
Italic characters	Referenced books	<i>MPLAB<sup>®</sup> IDE User's Guide</i>
	Emphasized text	...is the <i>only</i> compiler...
Initial caps	A window	the Output window
	A dialog	the Settings dialog
	A menu selection	select Enable Programmer
Quotes	A field name in a window or dialog	"Save project before build"
Underlined, italic text with right angle bracket	A menu path	<u><i>File</i></u> >Save
Bold characters	A dialog button	Click <b>OK</b>
	A tab	Click the <b>Power</b> tab
'bnnnn'	A binary number where <i>n</i> is a digit	'b00100, 'b10
Text in angle brackets < >	A key on the keyboard	Press <Enter>, <F1>
<b>Courier font:</b>		
Plain Courier	Sample source code	#define START
	Filenames	autoexec.bat
	File paths	c:\mcc18\h
	Keywords	_asm, _endasm, static
	Command-line options	-Opa+, -Opa-
	Bit values	0, 1
Italic Courier	A variable argument	<i>file.o</i> , where <i>file</i> can be any valid filename
0xnnnn	A hexadecimal number where <i>n</i> is a hexadecimal digit	0xFFFF, 0x007A
Square brackets [ ]	Optional arguments	mcc18 [options] <i>file</i> [options]
Curly brackets and pipe character: {   }	Choice of mutually exclusive arguments; an OR selection	errorlevel {0 1}
Ellipses...	Replaces repeated text	var_name [, var_name...]
	Represents code supplied by user	void main (void) { ... }

## RECOMMENDED READING

This user's guide describes how to use MCP1601 Evaluation Board (Rev. 1). Other useful documents are listed below and are available and recommended as supplemental reference resources.

### MCP1601 Data Sheet (DS21896)

This data sheet provides detailed information regarding the MCP1601 product family.

### Application Note 793, "Power Management in Portable Applications: Understanding the Buck Switchmode Power Converter", (DS00793)

This application note outlines a design procedure for buck regulators.

## THE MICROCHIP WEB SITE

Microchip provides online support via our web site at [www.microchip.com](http://www.microchip.com). This web site is used as a means to make files and information easily available to customers. Accessible by using your favorite Internet browser, the web site contains the following information:

- **Product Support** – Data sheets and errata, application notes and sample programs, design resources, user's guides and hardware support documents, latest software releases and archived software
- **General Technical Support** – Frequently Asked Questions (FAQ), technical support requests, online discussion groups, Microchip consultant program member listing
- **Business of Microchip** – Product selector and ordering guides, latest Microchip press releases, listing of seminars and events, listings of Microchip sales offices, distributors and factory representatives

## CUSTOMER SUPPORT

Users of Microchip products can receive assistance through several channels:

- Distributor or Representative
- Local Sales Office
- Field Application Engineer (FAE)
- Technical Support
- Development Systems Information Line

Customers should contact their distributor, representative or field application engineer (FAE) for support. Local sales offices are also available to help customers. A listing of sales offices and locations is included in the back of this document.

Technical support is available through the web site at: <http://support.microchip.com>

In addition, there is a Development Systems Information Line which lists the latest versions of Microchip's development systems software products. This line also provides information on how customers can receive currently available upgrade kits.

The Development Systems Information Line numbers are:

1-800-755-2345 – United States and most of Canada

1-480-792-7302 – Other International Locations

# MCP1601 Evaluation Board (Rev. 1) User's Guide

---

---

NOTES:



**Chapter 1. Product Overview**

**1.1 INTRODUCTION**

The MCP1601 Evaluation Board (Rev. 1) is designed to demonstrate the use of the MCP1601 Synchronous Buck Regulator in a step-down, inductor-based DC/DC converter application.

This document describes the capabilities of the MCP1601 Evaluation Board (Rev. 1) and how to select the desired synchronous converter operating mode, and to program the output voltage.

**Note:** This users guide applies to the 102-00033 MCP1601 Evaluation Board (Rev. 1). There is another version of the MCP1601 evaluation board that uses a different component set and is supplied with a separate user's guide.

The MCP1601 Evaluation Board (Rev. 1) Schematic is shown is Figure 1-1.

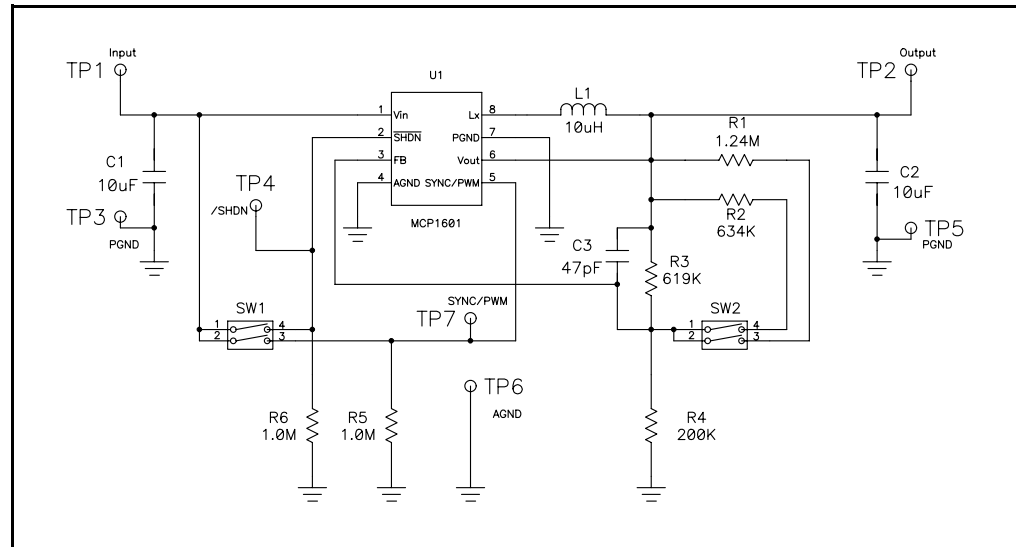

**FIGURE 1-1:** MCP1601 Evaluation Board (Rev. 1) Block Diagram.

# MCP1601 Evaluation Board (Rev. 1) User Guide

---

## 1.2 WHAT IS THE MCP1601 EVALUATION BOARD (REV. 1)?

The MCP1601 is a 500 mA synchronous buck regulator. Both the high-side buck P-channel and the low-side N-channel switches are integrated within the device. The integrated synchronous switch makes the MCP1601 very efficient, even when converting unregulated input voltages to low-voltage, fixed outputs. This evaluation board is designed for a wide range of output voltages and currents. For specific applications, smaller inductors, shielded inductors, tantalum capacitors and different output voltage settings can improve the total DC/DC converter performance and cost.

## 1.3 WHAT THE MCP1601 EVALUATION BOARD (REV. 1) KIT INCLUDES

This MCP1601 Evaluation Board (Rev. 1) Kit includes:

- The MCP1601 Evaluation Board (Rev. 1) (102-00033)
- MCP1601 Evaluation Board (Rev. 1) User's Guide (DS51511)
- MCP1601 Data Sheet (DS21762)

---

---

**Chapter 2. MCP1601 Evaluation Board (Rev. 1)**

---

---

**2.1 INTRODUCTION**

This chapter provides detailed information illustrating how to apply input power, connect load, select output voltage set points and select the operating mode for the MCP1601 Evaluation Board (Rev. 1). Board test point descriptions are also provided.

**2.2 FEATURES**

The MCP1601 device can operate in three different modes of operation to optimize the efficiency of the voltage conversion. The three operating modes are:

- Automatic switching from PFM mode to PWM mode, and back
- Synchronization to external oscillator
- Fixed-frequency forced PWM mode

The MCP1601 output voltage is adjustable and is set by two external divider resistors. A two-position switch is used on the MCP1601 Evaluation Board (Rev. 1) to change the resistance of the external divider and adjust the output voltage to four different settings. These output voltage settings are: 1.8V, 2.05V, 2.45V and 3.28V.

**2.3 GETTING STARTED****2.3.1 Applying Power to the Board**

Two surface-mount test points are used to apply power to the MCP1601 Evaluation Board (Rev. 1). For proper operation, the input voltage range is  $2.7V < +V_{IN} < +5.5V$  for all operating conditions. The MCP1601 has an internal Undervoltage Lockout (UVLO) that will prevent the board from operating when the input voltage is below the specified 2.7V minimum.

1. Connect the positive side of the external power supply (+) to the  $+V_{IN}$  test point.
2. Connect the negative side (GND) of the external power supply to the  $P_{GND}$  test point, located to the left of the  $+V_{IN}$  test point.

**2.3.2 Connecting a Load to the Board**

To connect an external load to the board, the  $+V_{OUT}$  and  $P_{GND}$  test points are used.

1. Connect the positive side of the load to the  $+V_{OUT}$  pin and the negative or ground side of the load to the  $P_{GND}$  test point, located to the right of the  $+V_{OUT}$  test point. The MCP1601 output is rated for 500 mA (maximum) continuous current. The output is protected against over current and short circuit conditions.

**2.3.3 Enabling the MCP1601 - Using Switch  $SW_1$ , Position 1**

Switch  $SW_1$ , position 1 is used to determine the Shutdown mode for the MCP1601 device. With switch  $SW_1$ , position 1 pushed to the right, the SHDN pin is pulled up and the output of the MCP1601 device is enabled. When switch  $SW_1$ , position 1 is to the left, the MCP1601 device is in a low quiescent current Shutdown mode and the output is disabled.

# MCP1601 Evaluation Board (Rev. 1) User Guide

## 2.3.4 Selecting the Operating Mode - Using Switch SW<sub>1</sub>, Position 2

The multi-function SYNC/PWM pin on the MCP1601 is used to set the operating mode of the device. The three operating modes are:

- Automatic switching from PFM mode to PWM mode, and back
- Synchronization to external oscillator
- Fixed-frequency forced PWM mode

To select automatic PFM/PWM mode:

1. Slide switch SW<sub>1</sub>, position 2 to the left (or off) position. While operating in this mode, the MCP1601 device will automatically select the most efficient operating mode by approximating the load current internally.

To synchronize the MCP1601 switching frequency to an external oscillator:

1. Slide switch SW<sub>1</sub>, position 2 to the left. Connect the external oscillator to the SYNC/PWM test point located below and to the right of switch SW<sub>1</sub> and the A<sub>GND</sub> test point. See the MCP1601 datasheet (DS21762) for external clock specifications. When synchronizing to an external oscillator, the MCP1601 will operate in the Fixed-frequency mode at the same frequency as the external oscillator.

To select the Fixed-frequency mode that operates off of the 750 kHz internal oscillator:

1. Slide switch SW<sub>1</sub>, position 2 to the right (or on) position. This will tie the SYNC/PWM pin high and force PWM operation from the internal oscillator, making the MCP1601 device independent of external load conditions.

## 2.3.5 Selecting the MCP1601 output voltage

Switch SW<sub>2</sub> is used to select the output voltage. Refer to Table 2-1 to choose one of the pre-selected output voltages.

**TABLE 2-1: SWITCH SETTINGS FOR PRE-SELECTED OUTPUT VOLTAGES**

SW <sub>2</sub> , Position 1	SW <sub>2</sub> , Position 2	V <sub>OUT</sub>
OFF	OFF	3.28V
OFF	ON	2.45V
ON	OFF	2.05V
ON	ON	1.8

The output voltage for the MCP1601 device is determined by using the following equation.

**EQUATION 2-1:**

$$V_{OUT} = V_{REF} \left( 1 + \frac{R_2}{R_4} \right)$$

Where:

V<sub>REF</sub> = 0.8V, typical

R<sub>4</sub> = 200 kΩ for the evaluation board

R<sub>2</sub> is set by the parallel combination of R<sub>1</sub>, R<sub>2</sub> and R<sub>3</sub>

## 2.4 TEST POINTS

### 2.4.1 Shutdown ( $\overline{\text{SHDN}}$ )

The  $\overline{\text{SHDN}}$  (or shutdown) test point can be used to either monitor the level of the shutdown pin or as an input to the shutdown pin of the MCP1601 device. With switch  $\text{SW}_1$ , position 1 in the off position, a 1 M $\Omega$  resistor will pull the pin low.

### 2.4.2 SYNC/PWM

The SYNC/PWM pin can be used to either monitor the level of the SYNC/PWM pin or as an input to the MCP1601 device. With switch  $\text{SW}_1$ , position 2 in the off position, a 1 M $\Omega$  resistor will pull the pin low.

To synchronize to an external oscillator:

1. With switch  $\text{SW}_1$ , position 2 in the off position, connect the external oscillator to the SYNC/PWM test point.

### 2.4.3 Analog Ground ( $A_{\text{GND}}$ )

The analog ground (or  $A_{\text{GND}}$ ) can be used as a quiet ground connection. When using the external oscillator synchronization function, connect the return or ground of the external oscillator to the  $A_{\text{GND}}$  test point.

# MCP1601 Evaluation Board (Rev. 1) User Guide

---

---

NOTES:

---

---

**Appendix A. Schematic and Layouts**

---

---

**A.1 INTRODUCTION**

This appendix contains the schematic and board layout diagrams for the MCP1601 Evaluation Board (Rev. 1).

The MCP1601 Evaluation Board (Rev. 1) is constructed using one silk-screen layer and two, 1 oz. metal wiring layers. The bottom metal wiring layer is a single ground plane routed to partition the P<sub>GND</sub> high-current return pin from the small-signal A<sub>GND</sub> return pin on the MCP1601 device.

Diagrams included in this appendix:

- Board Schematic
- Top Metal Layer
- Bottom Metal Layer

# MCP1601 Evaluation Board (Rev. 1) User Guide

## A.2 BOARD SCHEMATIC

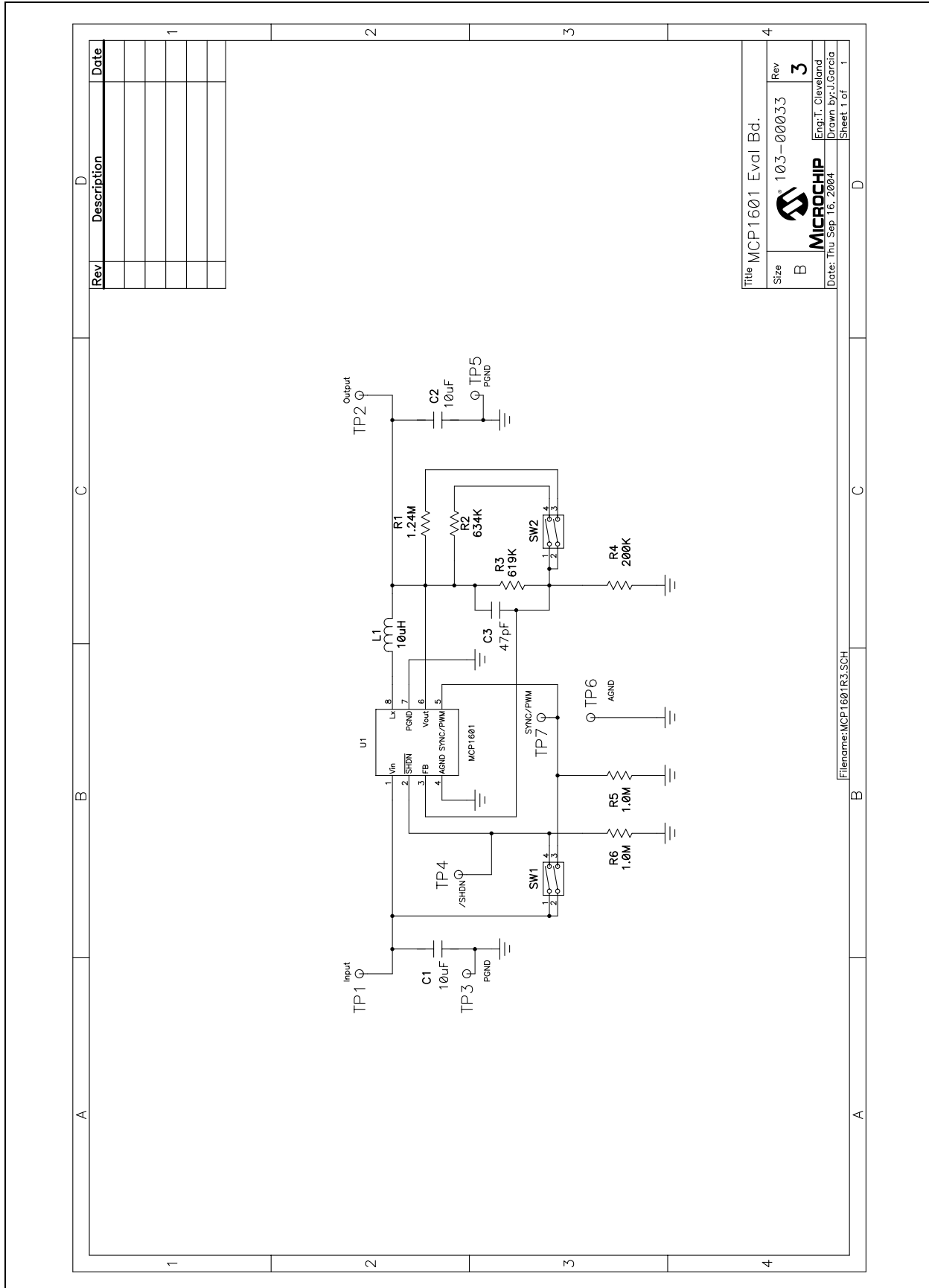

Rev	Description	Date

Title MCP1601 Eval Bd.		Rev	3
Size	B	103-00033	
 <b>MICROCHIP</b>		Eng: T. Cleveland Drawn by: J. Garcia Date: Thu Sep 16, 2004 Sheet 1 of 1	

Filename: MCP1601R3.SCH



A.3 BOARD - TOP LAYER

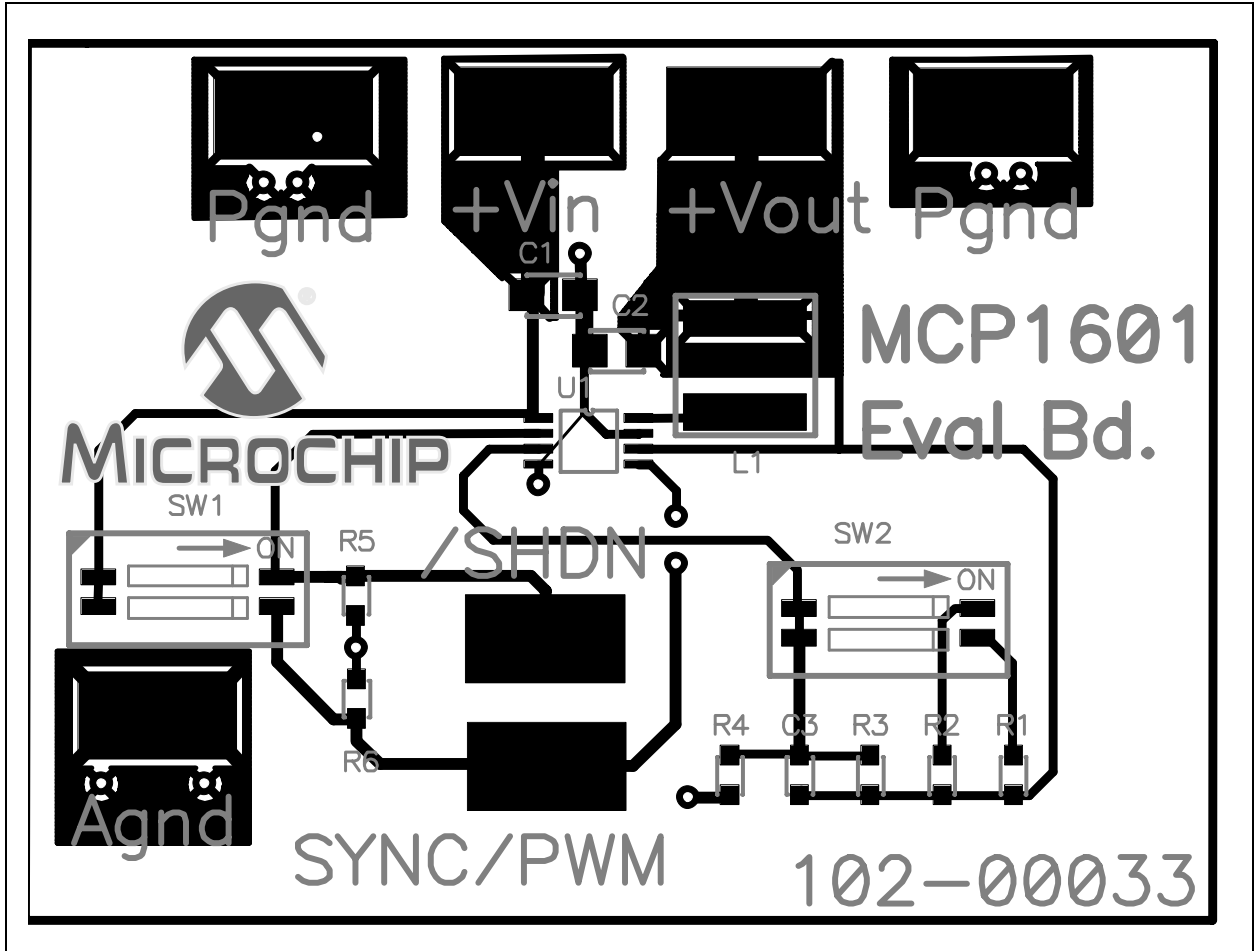

# MCP1601 Evaluation Board (Rev. 1) User Guide

## A.4 BOARD - BOTTOM LAYER

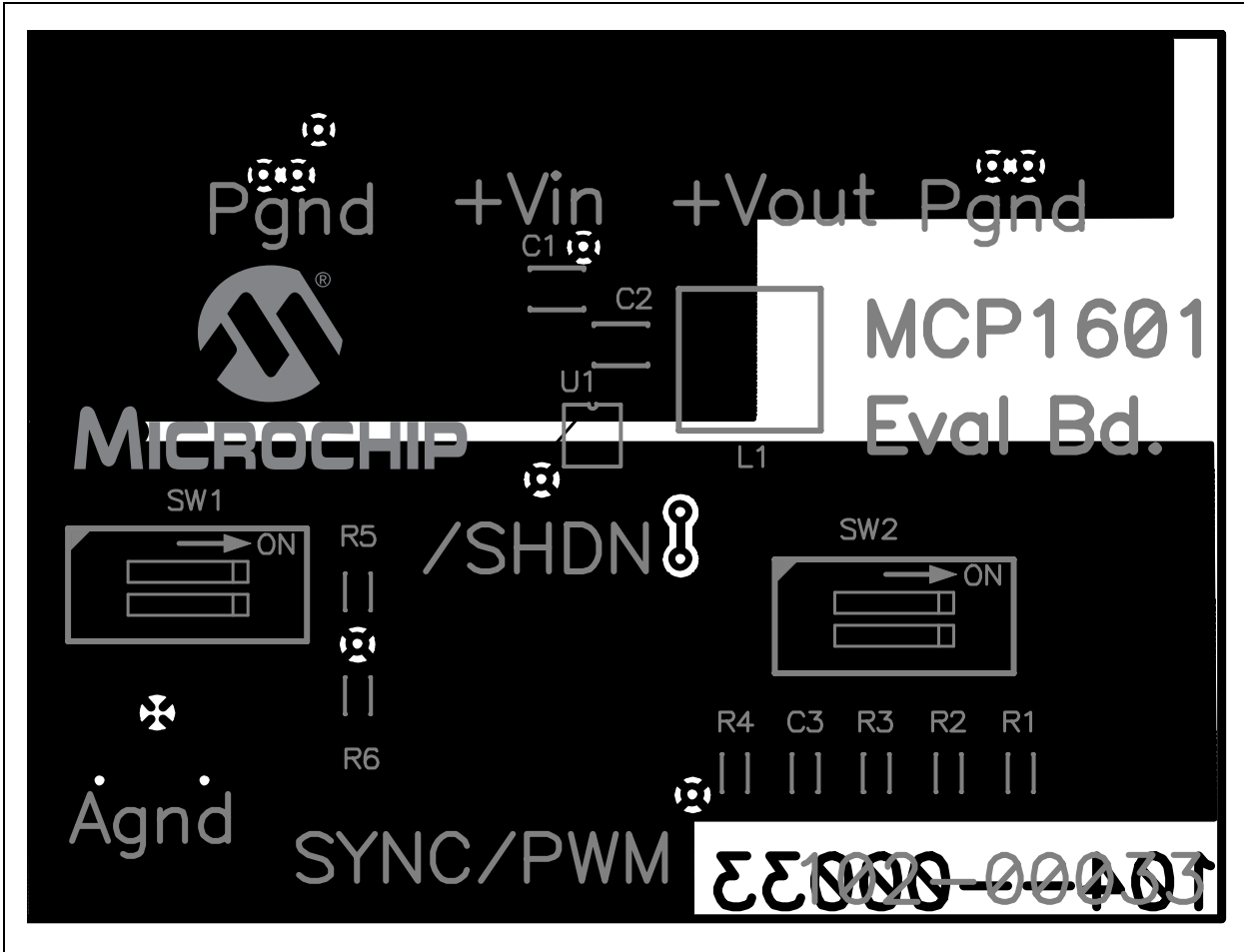

**Appendix B. Bill-Of-Materials (BOM)**

**TABLE B-1: BILL-OF-MATERIALS**

Qty	Reference	Description	Manufacturer	Part Number
1	R1	Resistor, 1.21 M $\Omega$ , 1/10W, 1%, 0603 SMD	Yageo America	9C06031A1214FKHFT
1	R2	Resistor, 634 k $\Omega$ , 1/16W, 1%, 0603 SMD	Panasonic <sup>®</sup> - ECG	ERJ-3EKF6343V
1	R3	Resistor, 619 k $\Omega$ , 1/16W, 1%, 0603 SMD	Panasonic - ECG	ERJ-3EKF6193V
1	R4	Resistor, 200 k $\Omega$ , 1/16W, 1%, 0603 SMD	Panasonic - ECG	ERJ-3EKF2003V
2	R5, R6	Resistor, 1.00 M $\Omega$ , 1/16W, 1%, 0603 SMD	Panasonic - ECG	ERJ-3EKF1004V
2	C1, C2	Capacitor, 10 $\mu$ F, 6.3V, Ceramic, X5R 0805	Panasonic - ECG	ECJ-2FB0J106M
1	C3	Capacitor, CERAMIC 68 pF 50V, 0603 SMD	Panasonic - ECG	ECJ-1VC1H680J
1	L1	Inductor Power Shield, 10 $\mu$ H, SMD	Coiltronics <sup>®</sup>	SD14-100
2	SW1, SW2	Switch Dip, 2pos, Half Pitch, SMT	C&K <sup>™</sup> .	TDA02H0SK1
2	PGND	Test Point Compact, SMT	Keystone Electronics <sup>®</sup>	5016
1	AGND	Test Point Compact, SMT	Keystone Electronics	5016
1	+VIN	Test Point Compact, SMT	Keystone Electronics	5016
1	+VOUT	Test Point Compact, SMT	Keystone Electronics	5016
1	SHDN	Test Point Compact, SMT	Keystone Electronics	5016
1	SYNC/PWM	Test Point Compact, SMT	Keystone Electronics	5016
4		Bumpons - Protective Products	3M <sup>®</sup>	SJ5003-0
1	U1	MCP1601 Buck Regulator	Microchip Technology Inc	MCP1601I



---

---

## WORLDWIDE SALES AND SERVICE

---

---

### AMERICAS

**Corporate Office**  
2355 West Chandler Blvd.  
Chandler, AZ 85224-6199  
Tel: 480-792-7200  
Fax: 480-792-7277  
Technical Support:  
http://support.microchip.com  
Web Address:  
www.microchip.com

**Atlanta**  
Alpharetta, GA  
Tel: 770-640-0034  
Fax: 770-640-0307

**Boston**  
Westford, MA  
Tel: 978-692-3848  
Fax: 978-692-3821

**Chicago**  
Itasca, IL  
Tel: 630-285-0071  
Fax: 630-285-0075

**Dallas**  
Addison, TX  
Tel: 972-818-7423  
Fax: 972-818-2924

**Detroit**  
Farmington Hills, MI  
Tel: 248-538-2250  
Fax: 248-538-2260

**Kokomo**  
Kokomo, IN  
Tel: 765-864-8360  
Fax: 765-864-8387

**Los Angeles**  
Mission Viejo, CA  
Tel: 949-462-9523  
Fax: 949-462-9608

**San Jose**  
Mountain View, CA  
Tel: 650-215-1444  
Fax: 650-961-0286

**Toronto**  
Mississauga, Ontario,  
Canada  
Tel: 905-673-0699  
Fax: 905-673-6509

### ASIA/PACIFIC

**Australia - Sydney**  
Tel: 61-2-9868-6733  
Fax: 61-2-9868-6755

**China - Beijing**  
Tel: 86-10-8528-2100  
Fax: 86-10-8528-2104

**China - Chengdu**  
Tel: 86-28-8676-6200  
Fax: 86-28-8676-6599

**China - Fuzhou**  
Tel: 86-591-750-3506  
Fax: 86-591-750-3521

**China - Hong Kong SAR**  
Tel: 852-2401-1200  
Fax: 852-2401-3431

**China - Shanghai**  
Tel: 86-21-5407-5533  
Fax: 86-21-5407-5066

**China - Shenyang**  
Tel: 86-24-2334-2829  
Fax: 86-24-2334-2393

**China - Shenzhen**  
Tel: 86-755-8203-2660  
Fax: 86-755-8203-1760

**China - Shunde**  
Tel: 86-757-2839-5507  
Fax: 86-757-2839-5571

**China - Qingdao**  
Tel: 86-532-502-7355  
Fax: 86-532-502-7205

### ASIA/PACIFIC

**India - Bangalore**  
Tel: 91-80-2229-0061  
Fax: 91-80-2229-0062

**India - New Delhi**  
Tel: 91-11-5160-8632  
Fax: 91-11-5160-8632

**Japan - Kanagawa**  
Tel: 81-45-471- 6166  
Fax: 81-45-471-6122

**Korea - Seoul**  
Tel: 82-2-554-7200  
Fax: 82-2-558-5932 or  
82-2-558-5934

**Singapore**  
Tel: 65-6334-8870  
Fax: 65-6334-8850

**Taiwan - Kaohsiung**  
Tel: 886-7-536-4818  
Fax: 886-7-536-4803

**Taiwan - Taipei**  
Tel: 886-2-2500-6610  
Fax: 886-2-2508-0102

**Taiwan - Hsinchu**  
Tel: 886-3-572-9526  
Fax: 886-3-572-6459

### EUROPE

**Austria - Weis**  
Tel: 43-7242-2244-399  
Fax: 43-7242-2244-393

**Denmark - Ballerup**  
Tel: 45-4420-9895  
Fax: 45-4420-9910

**France - Massy**  
Tel: 33-1-69-53-63-20  
Fax: 33-1-69-30-90-79

**Germany - Ismaning**  
Tel: 49-89-627-144-0  
Fax: 49-89-627-144-44

**Italy - Milan**  
Tel: 39-0331-742611  
Fax: 39-0331-466781

**Netherlands - Drunen**  
Tel: 31-416-690399  
Fax: 31-416-690340

**England - Berkshire**  
Tel: 44-118-921-5869  
Fax: 44-118-921-5820

09/27/04

Компания «Океан Электроники» предлагает заключение долгосрочных отношений при поставках импортных электронных компонентов на взаимовыгодных условиях!

Наши преимущества:

- Поставка оригинальных импортных электронных компонентов напрямую с производств Америки, Европы и Азии, а так же с крупнейших складов мира;
- Широкая линейка поставок активных и пассивных импортных электронных компонентов (более 30 млн. наименований);
- Поставка сложных, дефицитных, либо снятых с производства позиций;
- Оперативные сроки поставки под заказ (от 5 рабочих дней);
- Экспресс доставка в любую точку России;
- Помощь Конструкторского Отдела и консультации квалифицированных инженеров;
- Техническая поддержка проекта, помощь в подборе аналогов, поставка прототипов;
- Поставка электронных компонентов под контролем ВП;
- Система менеджмента качества сертифицирована по Международному стандарту ISO 9001;
- При необходимости вся продукция военного и аэрокосмического назначения проходит испытания и сертификацию в лаборатории (по согласованию с заказчиком);
- Поставка специализированных компонентов военного и аэрокосмического уровня качества (Xilinx, Altera, Analog Devices, Intersil, Interpoint, Microsemi, Actel, Aeroflex, Peregrine, VPT, Syfer, Eurofarad, Texas Instruments, MS Kennedy, Miteq, Cobham, E2V, MA-COM, Hittite, Mini-Circuits, General Dynamics и др.);

Компания «Океан Электроники» является официальным дистрибьютором и эксклюзивным представителем в России одного из крупнейших производителей разъемов военного и аэрокосмического назначения «JONHON», а так же официальным дистрибьютором и эксклюзивным представителем в России производителя высокотехнологичных и надежных решений для передачи СВЧ сигналов «FORSTAR».



## JONHON

«JONHON» (основан в 1970 г.)

Разъемы специального, военного и аэрокосмического назначения:

(Применяются в военной, авиационной, аэрокосмической, морской, железнодорожной, горно- и нефтедобывающей отраслях промышленности)

«FORSTAR» (основан в 1998 г.)

ВЧ соединители, коаксиальные кабели, кабельные сборки и микроволновые компоненты:

(Применяются в телекоммуникациях гражданского и специального назначения, в средствах связи, РЛС, а так же военной, авиационной и аэрокосмической отраслях промышленности).



Телефон: 8 (812) 309-75-97 (многоканальный)

Факс: 8 (812) 320-03-32

Электронная почта: [ocean@oceanchips.ru](mailto:ocean@oceanchips.ru)

Web: <http://oceanchips.ru/>

Адрес: 198099, г. Санкт-Петербург, ул. Калинина, д. 2, корп. 4, лит. А