

IS31LT3910

UNIVERSAL HIGH BRIGHTNESS LED DRIVER WITH TEMPERATURE COMPENSATION

November 2011

GENERAL DESCRIPTION

The IS31LT3910 is a peak current mode control LED driver IC. The IS31LT3910 operates in constant off-time mode. It allows efficient operation of High Brightness (HB) LEDs with voltage sources ranging from 8VDC to 450DC or 110VAC/220VAC. The IS31LT3910 includes a PWM dimming input that can accept an external control signal with a duty ratio of 0 - 100% and a frequency of up to a few kilohertz. It also includes a 0 - 240mV linear dimming input which can be used both for linear dimming and temperature compensation of the LED current.

The IS31LT3910 is ideally suited for buck LED drivers. Since the IS31LT3910 operates in peak current mode control, the controller achieves good output current regulation without the need for any loop compensation. It achieves good PWM dimming response because the response time is limited only by the rate of rise and fall of the inductor current, enabling very fast rise and fall time.

FEATURES

- Wide input range from 8VDC to 450DC or 110VAC/220 VAC
- Temperature compensation to regulate LED current
- Application from a few mA to more than 1A output
- Constant off-time operation
- Linear and PWM dimming capability
- Switch mode controller for single switch LED drivers
- Requires few external components for operation

APPLICATIONS

- DC/DC or AC/DC LED driver applications
- General purpose constant current source
- Signal and decorative LED lighting
- backlighting LED driver

APPLICATION CIRCUIT

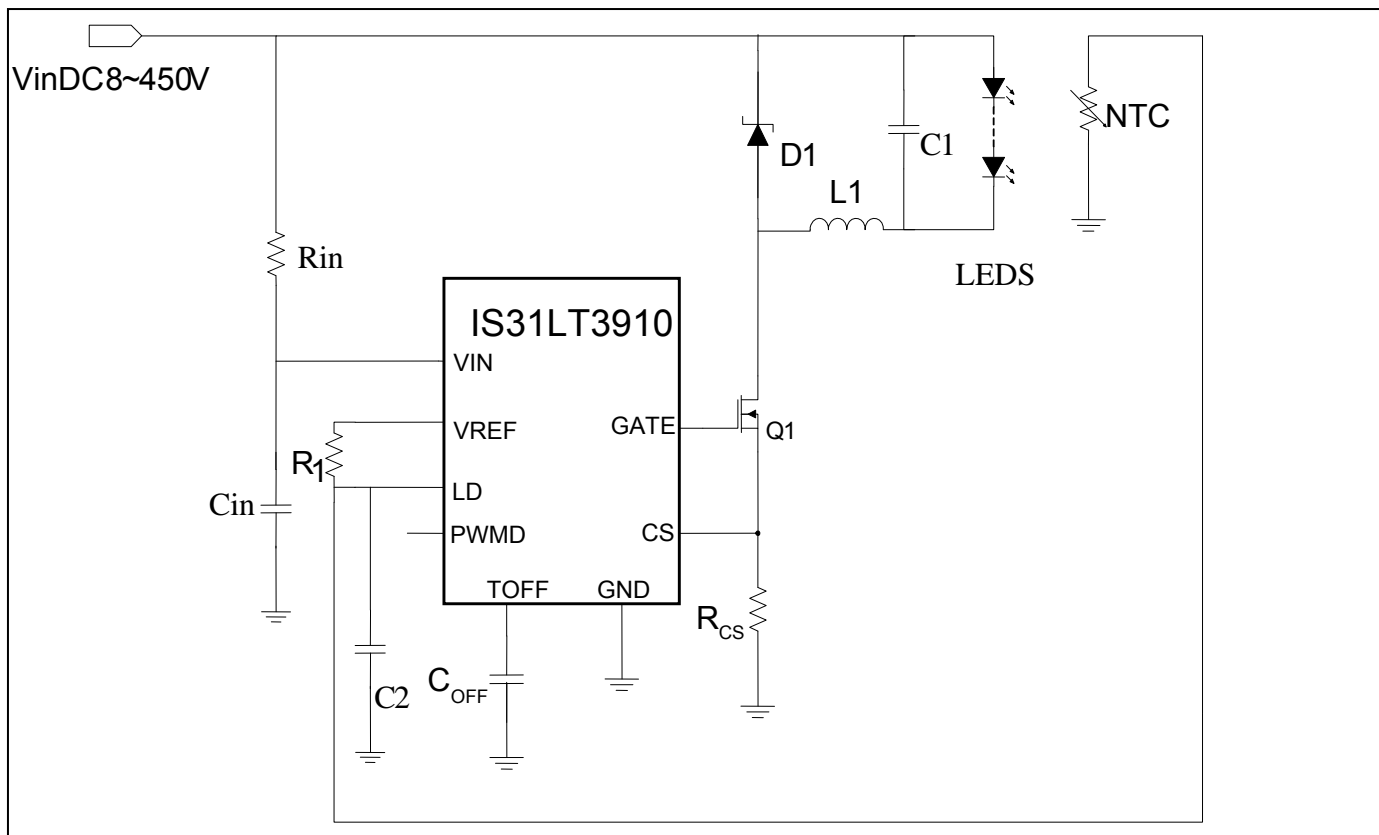

IS31LT3910

PIN CONFIGURATIONS

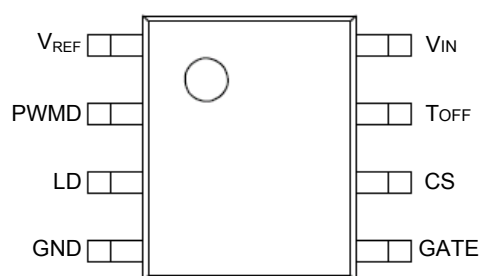
Package	Pin Configurations (Top View)
SOP-8	

PIN DESCRIPTION

Pin	Pin No.	Description
V_{REF}	1	This pin provides reference a voltage of 1.2V, no bypass capacitor is needed.
PWMD	2	This is the PWM dimming input of the IC. When this pin is pulled to GND, the gate driver is turned off. When the pin is pulled high, the gate driver operates normally.
LD	3	This pin is the linear dimming input and sets the current sense threshold as long as the voltage at the pin is less than 240mV (typ.). It can also used as temperature compensation threshold voltage.
GND	4	Ground return for all internal circuitry. This pin must be electrically connected to ground.
GATE	5	This pin is the output gate driver for an external N-channel power MOSFET.
CS	6	This pin is the current sense pin used to sense the MOSFET current by means of an external sense resistor. When this pin exceeds the lower of either the internal 240mV or the voltage at the LD pin, the gate output goes low.
T_{OFF}	7	This pin sets the off time of the power MOSFET. If left floating then the off time will be 510ns. When a capacitor is connected between T_{OFF} and GND, the off time is increased.
V_{IN}	8	This pin is the input of an 8V to 450V voltage supply through a resistor, clamped at 7.1V internally, it must be bypassed with a capacitor to GND.

Copyright © 2011 Integrated Silicon Solution, Inc. All rights reserved. ISSI reserves the right to make changes to this specification and its products at any time without notice. ISSI assumes no liability arising out of the application or use of any information, products or services described herein. Customers are advised to obtain the latest version of this device specification before relying on any published information and before placing orders for products. Integrated Silicon Solution, Inc. does not recommend the use of any of its products in life support applications where the failure or malfunction of the product can reasonably be expected to cause failure of the life support system or to significantly affect its safety or effectiveness. Products are not authorized for use in such applications unless Integrated Silicon Solution, Inc. receives written assurance to its satisfaction, that:

- a.) the risk of injury or damage has been minimized;
- b.) the user assume all such risks; and
- c.) potential liability of Integrated Silicon Solution, Inc is adequately protected under the circumstances



IS31LT3910

ORDERING INFORMATION

Industrial Range: -40°C to +85°C

Order Part No.	Package	QTY/Reel
IS31LT3910-GRLS2-TR	SOP-8, Lead-free	2500



IS31LT3910

ABSOLUTE MAXIMUM RATINGS

Parameter	Value
V _{IN} pin voltage to GND	-0.3V to 8V
CS, LD, PWMD, GATE, TOFF, VREF pin voltage to GND	-0.3V to 6V
V _{IN} pin Input Current Range (Note 1)	1mA to 10mA
Junction Temperature Range	-40°C to 150°C
Storage Temperature Range	-65°C to 150°C
ESD Human Model	2000V
R _{θJA}	80°C/W

Note: Stresses beyond those listed under absolute maximum ratings may cause permanent damage to the device. These are stress ratings only, and functional operation of the device at these or any other conditions beyond those indicated under recommended operating conditions is not implied. Exposure to absolute-maximum-rated conditions for extended periods may affect device reliability.

ELECTRICAL CHARACTERISTICS

(The specifications are at T_A=25°C and V_{INDC}=10V (Note 1), R_{IN}=2K, unless otherwise noted)

Symbol	Parameter	Conditions	Min.	Typ.	Max.	Unit
V _{INDC}	Input DC supply voltage range	Connect a decent resistor from DC supply voltage to V _{IN} pin (Note 2)	8		450	V
V _{IN_clamp}	V _{IN} clamp voltage	(Note 3)	6.6	7.1	7.6	V
I _{IN}	Operation current range	V _{IN} =6V GATE floating	0.32	0.5	0.64	mA
UVLO	Undervoltage lockout threshold	V _{IN} rising	6.0	6.5	6.9	V
ΔUVLO	Undervoltage lockout hysteresis	V _{IN} falling		500		mV
V _{EN(lo)}	Pin PWMD input low voltage				1.2	V
V _{EN(hi)}	Pin PWMD input high voltage		2			V
R _{EN}	Pin PWMD pull-up resistance		75	100	125	KΩ
V _{CS,TH}	Current sense pull-in threshold voltage		215	240	265	mV
V _{LD}	Linear Dimming pin voltage low threshold			0.05		mV
	Linear Dimming pin voltage high threshold			0.24		mV
T _{BLANK}	Current sense blanking interval		400	480	550	ns
t _{DELAY}	Delay to output	V _{CS} =V _{CS,TH} +50mV after T _{BLANK}		30		ns
T _{OFF}	Off Time	T _{OFF} pin Floating	420	510	600	ns
t _{RISE}	GATE output rise time	C _{GATE} =500pF		19		ns
t _{FALL}	GATE output fall time	C _{GATE} =500pF		29		ns
V _{REF}	REF pin voltage		1.12	1.20	1.30	V
V _{REFLOAD}	Load regulation of reference voltage	I _{REF} =0~500uA, PWMD=5.0V		0.5	5	mV

Note 1: All parameters are tested at 25°C. Specifications over temperature are guaranteed by design.

Note 2: V_{INDC} is the power supply to LED, and there should be an appropriate resistor between V_{INDC} and V_{IN}.

Note 3: Beyond the input current range, V_{IN} may not clamp at 7.1V.

IS31LT3910

APPLICATION INFORMATION

The IS31LT3910 is optimized to drive buck LED drivers using peak current mode control. This control method provides fairly accurate LED current control without the need for a high side current sensing or the design of any additional loop compensation. The IC uses very few external components and provides for either Linear or PWM control of the LED current.

A capacitor connected to the T_{off} pin programs the off-time of the oscillator inside. The oscillator produces pulses at regular intervals. These pulses set the SR flip-flop in the IS31LT3910 which causes the GATE driver to turn on. When the MOSFET turns on, the current through the inductor starts ramping up. This current flows through the external sense resistor R_{CS} and produces a ramp voltage at the CS pin. The comparators are constantly comparing the CS pin voltage to both the voltage at the LD pin and the internal 240mV. Once the blanking time is complete, the output of these comparators is allowed to reset the flip flop. When the output of either one of the two comparators goes high, the flip flop is reset and the GATE output goes low. If neither of the comparator goes high, the GATE keeps high. Assuming a 30% ripple in the inductor, the current sense resistor R_{CS} can be set by using:

$$R_{CS} = \frac{0.24V(orV_{LD})}{1.15 \bullet I_{LED}(A)}$$

A constant off-time peak current control scheme can easily operate at duty cycles greater than 0.5 and also gives inherent input voltage rejection making the LED current almost insensitive to input voltage variations.

INPUT VOLTAGE REGULATOR

When a voltage is applied through a suitable input resistor to the V_{IN} pin, the IS31LT3910 maintains a constant 7.1V (typ.) at the V_{IN} pin. This voltage is used to power the IC. The V_{IN} pin must be bypassed by a low ESR capacitor to provide a low impedance path for the high frequency current of the output GATE driver.

The input current drawn from the V_{IN} pin is a sum of the 0.5mA(typ) current drawn by the internal circuit and the current drawn by the GATE driver (which in turn depends on the switching frequency and the GATE charge of the external MOSFET).

$$I_{IN} \approx 0.5mA + Q_G \bullet f_s$$

In the above equation, f_s is the switching frequency and Q_G is the GATE charge of the external MOSFET (which can be obtained from the datasheet of the MOSFET).

CURRENT SENSE

The current sense input of the IS31LT3910 goes to the non-inverting inputs of two comparators. The inverting terminal of one comparator is tied to an internal 240mV reference whereas the inverting terminal of the other comparator is connected to the LD pin. The outputs of both these comparators are fed into an OR GATE and the output of the OR GATE is fed into the reset pin of the flip-flop. Thus, the comparator which has the lowest voltage at the inverting terminal determines when the GATE output is turned off.

The outputs of the comparators also include a typical 480ns blanking time which prevents spurious turn-offs of the external MOSFET due to the turn-on spike normally present in peak current mode control. In rare cases, this internal blanking time might not be enough to filter out the turn-on spike. In these cases, an external RC filter needs to be added between the external sense resistor (R_{CS}) and the CS pin.

Please note that the comparators are relatively fast with a typical 80ns response time. A proper layout minimizing external inductances will prevent false triggering of these comparators.

OSCILLATOR

The oscillator in the IS31LT3910 is controlled by a single capacitor connected at the T_{off} pin. The equation governing the Toff-time of oscillation period is given by:

$$T_{OFF_TIME} (s) = 0.51 \times 10^{-6} \times \left(1 + \frac{C_{OFF}}{10pF}\right)$$

LINEAR DIMMING

The Linear Dimming pin is used to control the LED current. An external voltage ranging from 50mV to 240mV can be applied to the LD pin to adjust the LED current during operation. There are two cases when it may be necessary to use the Linear Dimming pin.

► In some cases, it may not be possible to find the exact R_{CS} value required to obtain the LED current when the internal 240mV is used. In these cases, an external voltage divider from the V_{in} pin can be connected to the LD pin to obtain a voltage (less than 240mV) corresponding to the desired voltage across R_{CS} .

► Linear dimming may be desired to adjust the current level to reduce the brightness of the LEDs. Connecting a resistor between the V_{ref} pin and the LD pin, and also connecting an NTC thermistor between the LD pin and ground (refer to Application Circuit), the IS31LT3910 is able to realize the temperature compensation function

IS31LT3910

(See more detail in Temperature Compensation section).

To use the internal 240mV, the LD pin must be connected to PWMD pin.

PWM DIMMING

PWM Dimming can be achieved by driving the PWMD pin with a low frequency square wave signal. When the PWM signal is low, the GATE driver is disabled; and when the PWMD signal is high, the GATE driver is enabled. Since the PWMD signal does not turn off the other parts of the IC, the response of the IS31LT3910 to the PWMD signal is almost instantaneous. The rate of rise and fall of the LED current is thus determined solely by the rise and fall times of the inductor current.

To disable PWM dimming function, leave the PWMD pin floating.

TEMPERATURE COMPENSATION

IS31LT3910 provides thermal protection for your LEDs. Refer to application circuit, adding a NTC thermistor close to the LEDs string will realize the temperature compensation of LEDs current. If the temperature of the LEDs rises, the resistance of the NTC thermistor decreases until the voltage of the LD pin falls below 0.24V. Then the average current is controlled by the LD pin and the temperature compensation function starts. The formula is given as below:

$$\frac{R_{NTC} \cdot V_{ref}}{R_1 + R_{NTC}} = 0.24$$

Assuming a 30% ripple in the inductor, the temperature compensated continuous current may be computed as:

$$I_{out} = \frac{R_{NTC} \cdot V_{ref}}{(R_1 + R_{NTC}) \cdot R_S \cdot 1.15}$$

Make sure the value of R1 is more than 1K.

When the LD pin voltage reduces to less than 50mv, the chip is shutdown .

After the ambient temperature returns to a safe temperature, the current will return to the set value.

Example

DC input voltage: $V_{INDC}=230V$

Output LED strings: $V_O=134.4V$ (42 LEDs in series, 3.2V for each one),

$I_{O_AVG}=160mA$ (8 parallels LEDs, 20mA for each one)

IC INPUT RESISTOR (R_{IN}) AND HOLD CAPACITOR (C_{IN})

$$R_{IN} = \frac{V_{INDC} - V_{IN}}{I_{IN}} = \frac{230 - 7.0}{1} \approx 223K$$

parallel two 430 k Ω /0.5W resistor for lifetime consideration. C_{IN} is chosen to be 10uF/ 40V capacitor

T_{OFF} TIME REGULATION CAPACITOR (C_{OFF}) AND TOFF TIME

For high output voltage, low output current application, we need shorter T_{off} Time to obtain the smaller application inductor. For high output current application, it is suggested that the frequency is set to not more than 50KHz (typical 25~30KHz). In IS31LT3910,

$$T_{OFF_TIME} = 0.51 \times 10^{-6} \times \left(1 + \frac{C_{OFF}}{10pF}\right)$$

So, apply $C_{off}=150pF$, then $T_{off}=8.16us$

CURRENT SENSE RESISTOR (RCS)

Design for low current ripple will also improve current accuracy, but it will require a large value of inductor. High current ripple allows a lower cost inductor. So we need to consider these two factors when selecting an inductor.

A capacitor placed in parallel with the array of LEDs can be used to reduce the LED current ripple while keeping the same average current. A typical value is 1uF should be used.

Since the output average $I_{O_AVG} = 160mA$, Assume 50% current ripple, then

$$\frac{1}{2} I_{Ripple} = \frac{1}{2} \cdot 50\% \cdot 160mA = 40mA$$

$$I_{O_PEAK} = I_{O_AVG} + \frac{1}{2} I_{Ripple} = 200mA$$

$$R_{CS} = \frac{0.24V}{200mA} = 1.2\Omega$$

THE INDUCTOR (L1) CHOSEN

The inductor value depends on the ripple current in the LEDs. $T_{off}=8.16us$

$$L = \frac{V_O \times T_{OFF}}{I_{Ripple}} = \frac{134.4 \times 8.16}{80} \approx 13.7mH$$

The inductor chosen should have a saturation current higher than the peak output current and a continuous current rating above the required mean output current.



IS31LT3910

The DC resistance (DCR) of the inductor is also essential when choosing an inductor. Bigger DCR will lead to more heat. The value of the inductor will reduce as its temperature rises, leading to higher current ripple, which in turn, reduces the average output current.

MOSFET (Q1) AND DIODE (D1)

The peak voltage seen by the MOSFET is equal to the maximum input voltage. Using a 50% safety rating,

$$V_{FET} = 1.5 \times V_{INDC}$$

The maximum RMS current through the MOSFET depends on the maximum current. Hence, the current rating of the MOSFET is:

$$I_{FET} = I_{PEAK} \bullet 150\%$$

For this application, choose a MOSFET 600V, 1A to 2A. 2N60 is good choice.

The peak voltage rating of the diode is the same as the FET. The current range of the diode is:

$$I_{diode} = I_{PEAK} \bullet 150\%$$

For this example, 600V/1A fast recovery diode is recommended.

IS31LT3910

PACKAGE INFORMATION

SOP-8

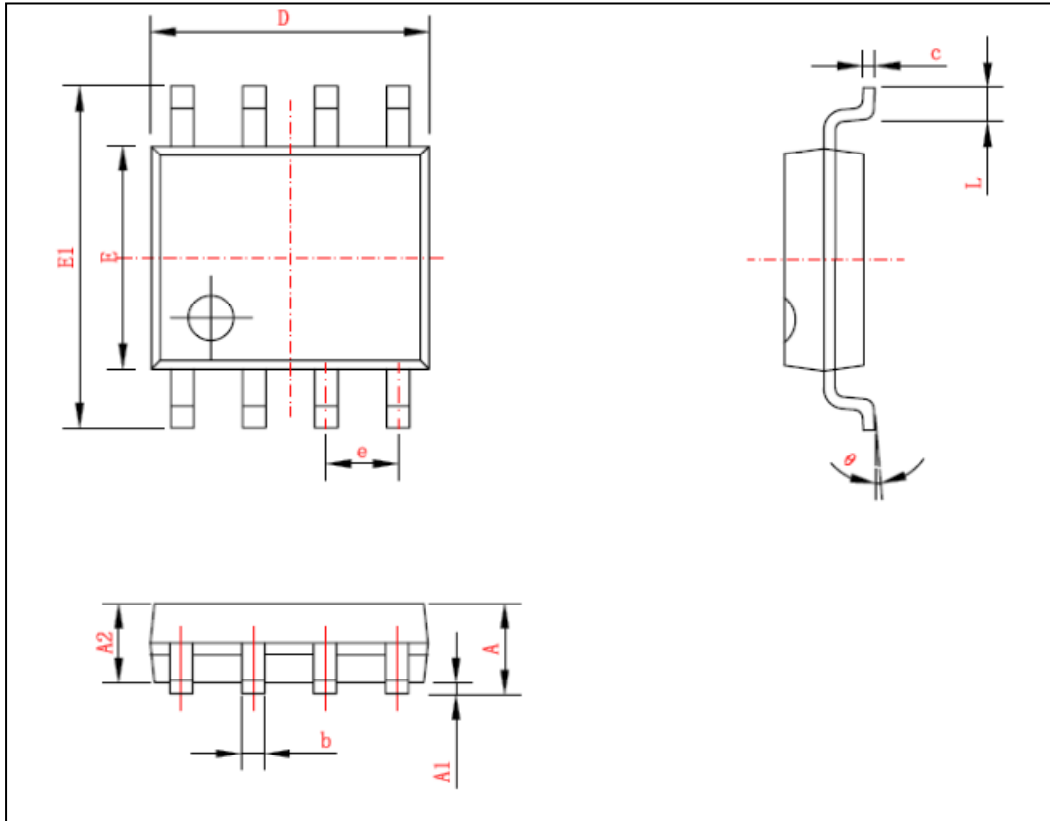

Symbol	Dimensions In Millimeters		Dimensions In Inches	
	Min	Max	Min	Max
A	1.350	1.750	0.053	0.069
A1	0.100	0.250	0.004	0.010
A2	1.450TYP		0.057TYP	
b	0.350	0.490	0.014	0.019
c	0.178	0.250	0.007	0.010
D	4.800	5.000	0.189	0.197
E	3.800	4.000	0.150	0.157
E1	5.800	6.240	0.228	0.246
e	1.270TYP		0.050TYP	
L	0.400	1.270	0.016	0.050
θ	0°	8°		

Компания «Океан Электроники» предлагает заключение долгосрочных отношений при поставках импортных электронных компонентов на взаимовыгодных условиях!

Наши преимущества:

- Поставка оригинальных импортных электронных компонентов напрямую с производств Америки, Европы и Азии, а так же с крупнейших складов мира;
- Широкая линейка поставок активных и пассивных импортных электронных компонентов (более 30 млн. наименований);
- Поставка сложных, дефицитных, либо снятых с производства позиций;
- Оперативные сроки поставки под заказ (от 5 рабочих дней);
- Экспресс доставка в любую точку России;
- Помощь Конструкторского Отдела и консультации квалифицированных инженеров;
- Техническая поддержка проекта, помощь в подборе аналогов, поставка прототипов;
- Поставка электронных компонентов под контролем ВП;
- Система менеджмента качества сертифицирована по Международному стандарту ISO 9001;
- При необходимости вся продукция военного и аэрокосмического назначения проходит испытания и сертификацию в лаборатории (по согласованию с заказчиком);
- Поставка специализированных компонентов военного и аэрокосмического уровня качества (Xilinx, Altera, Analog Devices, Intersil, Interpoint, Microsemi, Actel, Aeroflex, Peregrine, VPT, Syfer, Eurofarad, Texas Instruments, MS Kennedy, Miteq, Cobham, E2V, MA-COM, Hittite, Mini-Circuits, General Dynamics и др.);

Компания «Океан Электроники» является официальным дистрибьютором и эксклюзивным представителем в России одного из крупнейших производителей разъемов военного и аэрокосмического назначения «JONHON», а так же официальным дистрибьютором и эксклюзивным представителем в России производителя высокотехнологичных и надежных решений для передачи СВЧ сигналов «FORSTAR».



JONHON

«JONHON» (основан в 1970 г.)

Разъемы специального, военного и аэрокосмического назначения:

(Применяются в военной, авиационной, аэрокосмической, морской, железнодорожной, горно- и нефтедобывающей отраслях промышленности)

«FORSTAR» (основан в 1998 г.)

ВЧ соединители, коаксиальные кабели, кабельные сборки и микроволновые компоненты:

(Применяются в телекоммуникациях гражданского и специального назначения, в средствах связи, РЛС, а так же военной, авиационной и аэрокосмической отраслях промышленности).



Телефон: 8 (812) 309-75-97 (многоканальный)

Факс: 8 (812) 320-03-32

Электронная почта: ocean@oceanchips.ru

Web: <http://oceanchips.ru/>

Адрес: 198099, г. Санкт-Петербург, ул. Калинина, д. 2, корп. 4, лит. А