

Two Channel, Five Level, High Speed Ultrasound Driver IC

Features

- ▶ Advanced CMOS technology
- ▶ ± 4.75 to 12.9V gate drive voltage
- ▶ 2A output source and sink current
- ▶ 6.5ns rise and fall time with 1nF load
- ▶ 10ns propagation delay
- ▶ ± 2 ns matched delay times
- ▶ 12 matched channels
- ▶ 1.8V to 3.3V CMOS logic interface
- ▶ Smart logic threshold
- ▶ Low inductance package

Applications

- ▶ Medical ultrasound imaging
- ▶ Piezoelectric transducer drivers
- ▶ Metal flaw detection
- ▶ Non-Destructive Testing (NDT)

General Description

The Supertex MD1715, paired with the Supertex TC8020, forms a two channel, five level, high voltage, high speed transmit pulser chip set. The chip set is designed for medical ultrasound imaging applications, but can also be used for metal flaw detection, Non-Destructive Testing (NDT), and piezoelectric transducer drivers.

The MD1715 is a two channel logic controller circuit with 12 low impedance MOSFET gate drivers. There are two sets of control logic inputs, one each for channels A and B. Each channel consists of three pairs of MOSFET gate drivers. These drivers are designed to match the drive requirements of the Supertex TC8020.

The TC8020 is the output stage of the pulser, with six pairs of MOSFETs. Each pair consists of a P-channel and an N-channel MOSFET. They are designed to have the same impedance and can provide typical peak currents of ± 3.5 amps at 200V.

Typical Application Circuit

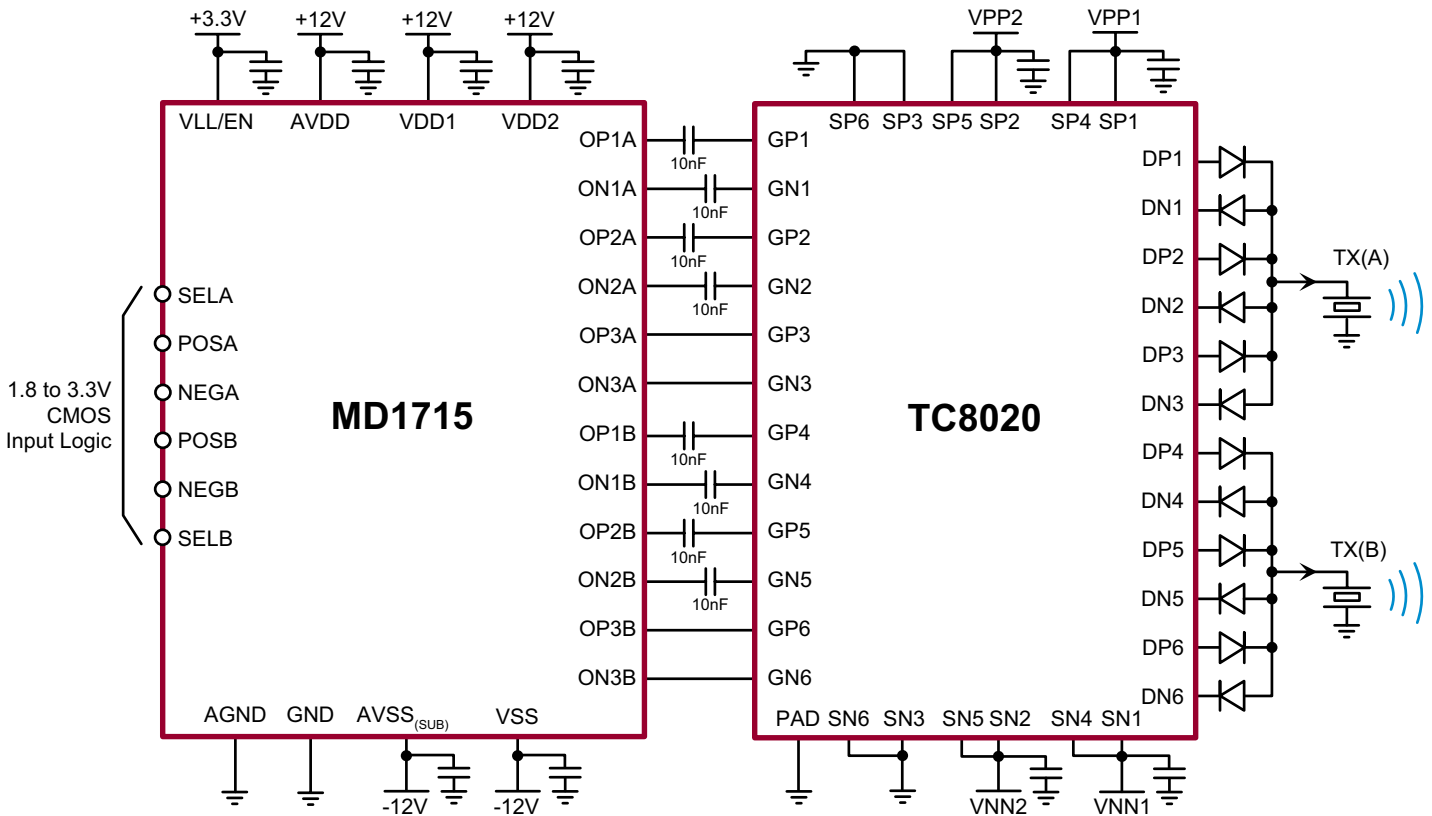

Ordering Information

Device	Package Option
	40-Lead QFN 6.00x6.00mm body 1.0mm height (max) 0.50mm pitch
MD1715	MD1715K6-G

-G indicates package is RoHS compliant ('Green')



Absolute Maximum Ratings

Parameter	Value
GND and AGND, Ground	0V
V_{LL} logic input pin	-0.5V to +5.5V
AV_{DD} , V_{DD1} , positive gate drive supply	-0.5V to +14.5V
V_{DD2} , positive gate drive supply	-0.5V to +14.5V
AV_{SS} , V_{SS} , negative gate drive supply	-14.5V to +0.5V
Storage temperature	-65°C to 150°C
Power dissipation*	1.3W

Absolute Maximum Ratings are those values beyond which damage to the device may occur. Functional operation under these conditions is not implied. Continuous operation of the device at the absolute rating level may affect device reliability. All voltages are referenced to device ground.

* 1.0oz 4-layer 3x4" PCB

Pin Configuration

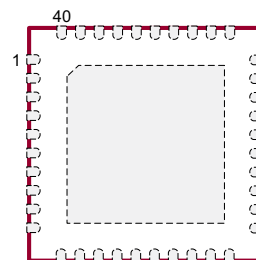

40-Lead QFN (K6)
(top view)

Package Marking



L = Lot Number
YY = Year Sealed
WW = Week Sealed
A = Assembler ID
C = Country of Origin
— = "Green" Packaging

Package may or may not include the following marks: Si or

40-Lead QFN (K6)

Operating Supply Voltages

Sym	Parameter	Min	Typ	Max	Units	Conditions
V_{LL}	Logic supply	1.8	3.3	3.6	V	---
AV_{DD}	Positive analog supply	8.0	-	12.9	V	$AV_{DD} \geq (V_{DD1} \text{ or } V_{DD2})$
V_{DD2} , V_{DD1}	Positive gate drive supply	4.75	-	12.9	V	---
AV_{SS} , V_{SS}	Negative gate drive supply	-12.9	-	-4.75	V	---

Operating Supply Current

(Over operating conditions unless otherwise specified, $V_{LL} = 3.3V$, $AV_{DD} = V_{DD1} = V_{DD2} = +12V$, $AV_{SS} = V_{SS} = -12V$, $T_A = 25^\circ C$)

Sym	Parameter	Min	Typ	Max	Units	Conditions
I_{VLL}	Logic reference current		10		μA	$V_{LL} = 3.3V$
I_{AVDDQ}	AV_{DD} power down current	-	0.4	-	mA	EN = 0, all inputs Low.
I_{VSSQ}	V_{SS} power down current	-	0.1	-		
I_{VDD1Q}	V_{DD1} power down current	-	10	25	μA	
I_{VDD2Q}	V_{DD2} power down current	-	10	25		

Operating Supply Current

(Over operating conditions unless otherwise specified, $V_{LL} = 3.3V$, $AV_{DD} = V_{DD1} = V_{DD2} = +12V$, $AV_{SS} = V_{SS} = -12V$, $T_A = 25^\circ C$)

Sym	Parameter	Min	Typ	Max	Units	Conditions
I_{AVDDEN}	AV_{DD} power up current	-	2.0	3.0	mA	EN = 1, all inputs low.
I_{VSSSEN}	V_{SS} power up current	-	0.7	1.0	mA	
I_{VDD1EN}	V_{DD1} power up current	-	10	-	μA	
I_{VDD2EN}	V_{DD2} power up current	-	10	-	μA	
I_{AVDDCW}	AV_{DD} CW 5MHz current	-	10	-	mA	A&B channel on at 5.0MHz no load, $V_{DD1} = 12V$, $V_{DD2} = 5.0V$
I_{VSSCW}	V_{SS} CW 5MHz current	-	5.0	-		
I_{VDD1CW}	V_{DD1} CW 5MHz current	-	25	-	mA	A&B channel on at 5.0MHz no load, $V_{DD1} = 5.0V$, $V_{DD2} = 12V$
I_{VDD2CW}	V_{DD2} CW 5MHz current	-	25	-	mA	A&B channel on at 5.0MHz no load, $V_{DD1} = 12V$, $V_{DD2} = 5.0V$

AC Electrical Characteristics

(Over operating conditions unless otherwise specified, $V_{LL} = 3.3V$, $AV_{DD} = V_{DD1} = V_{DD2} = +12V$, $AV_{SS} = V_{SS} = -12V$, $T_A = 25^\circ C$)

Sym	Parameter	Min	Typ	Max	Units	Conditions
t_{irf}	Input rise & fall time	-	-	10	ns	Logic input edge speed requirement
t_r	Output rise time	-	6.5	-	ns	1nF load, see timing diagram, input signal rise/fall time 2.0ns
t_f	Output fall time	-	6.5	-	ns	---
t_{dr}	Output rise delay	-	10	-	ns	---
t_{df}	Output fall delay	-	10	-	ns	---
$ t_r - t_f $	Rise and fall time matching	-	1.0	-	-	For each channel
$ t_{dr} - t_{df} $	Propagation delay matching	-	1.0	-	-	---
t_{dm}	Delay time matching	-	± 2.0	-	ns	Ch to Ch and Device to Device
Δt_j	Output jitter	-	20	-	ps	$V_{DD} = 10V$
t_{EN_ON}	IC enable time	-	25	50	μs	---
t_{EN_OFF}	IC disable time	-	0.5	2.0	μs	---
HD2	2 nd harmonic distortion	-40	-	-	dB	---

P-Channel Gate Driver Outputs

Sym	Parameter	Min	Typ	Max	Units	Conditions
R_{SINK}	Output sink resistance	-	5.0	6.0	Ω	$I_{SINK} = 100mA$
R_{SOURCE}	Output source resistance	-	5.0	6.0	Ω	$I_{SOURCE} = 100mA$
I_{SINK}	Peak output sink current	1.7	2.0	-	A	---
I_{SOURCE}	Peak output source current	1.7	2.0	-	A	---

N-Channel Gate Driver Outputs

Sym	Parameter	Min	Typ	Max	Units	Conditions
R_{SINK}	Output sink resistance	-	5.0	6.0	Ω	$I_{SINK} = 100mA$
R_{SOURCE}	Output source resistance	-	5.0	6.0	Ω	$I_{SOURCE} = 100mA$
I_{SINK}	Peak output sink current	1.7	2.0	-	A	---
I_{SOURCE}	Peak output source current	1.7	2.0	-	A	---

Logic Inputs

Sym	Parameter	Min	Typ	Max	Units	Conditions
V_{ENL}	Chip disable low voltage	0	-	0.3	V	VLL/EN is a dual function pin
V_{IH}	Input logic high voltage	$0.8V_{LL}$	-	V_{LL}	V	---
V_{IL}	Input logic low voltage	0	-	$0.2V_{LL}$	V	---
I_{IH}	Input logic high current	-	-	1.0	μA	---
I_{IL}	Input logic low current	-1.0	-	-	μA	---

Truth Table for Channels A and B

EN	Logic Inputs A			SP1 to DP1	SN1 to DN1	SP2 to DP2	SN2 to DN2	SP3 to DP3	SN3 to DN3
	SELA	POSA	NEGA						
1	0	0	0	OFF	OFF	OFF	OFF	ON	ON
1	0	0	1	OFF	OFF	OFF	ON	OFF	OFF
1	0	1	0	OFF	OFF	ON	OFF	OFF	OFF
1	0	1	1	OFF	OFF	OFF	OFF	OFF	OFF
1	1	0	0	OFF	OFF	OFF	OFF	ON	ON
1	1	0	1	OFF	ON	OFF	OFF	OFF	OFF
1	1	1	0	ON	OFF	OFF	OFF	OFF	OFF
1	1	1	1	OFF	OFF	OFF	OFF	OFF	OFF
EN	Logic Inputs B			SP4 to DP4	SN4 to DN4	SP5 to DP5	SN5 to DN5	SP6 to DP6	SN6 to DN6
	SELB	POSB	NEGB						
1	0	0	0	OFF	OFF	OFF	OFF	ON	ON
1	0	0	1	OFF	OFF	OFF	ON	OFF	OFF
1	0	1	0	OFF	OFF	ON	OFF	OFF	OFF
1	0	1	1	OFF	OFF	OFF	OFF	OFF	OFF
1	1	0	0	OFF	OFF	OFF	OFF	ON	ON
1	1	0	1	OFF	ON	OFF	OFF	OFF	OFF
1	1	1	0	ON	OFF	OFF	OFF	OFF	OFF
1	1	1	1	OFF	OFF	OFF	OFF	OFF	OFF
0	X	X	X	OFF	OFF	OFF	OFF	ON	ON
0→1	0	0	0	EN transitions from low to high or high to low should occur at all logic inputs low.					
1→0	0	0	0						

Circuit Pin Layout

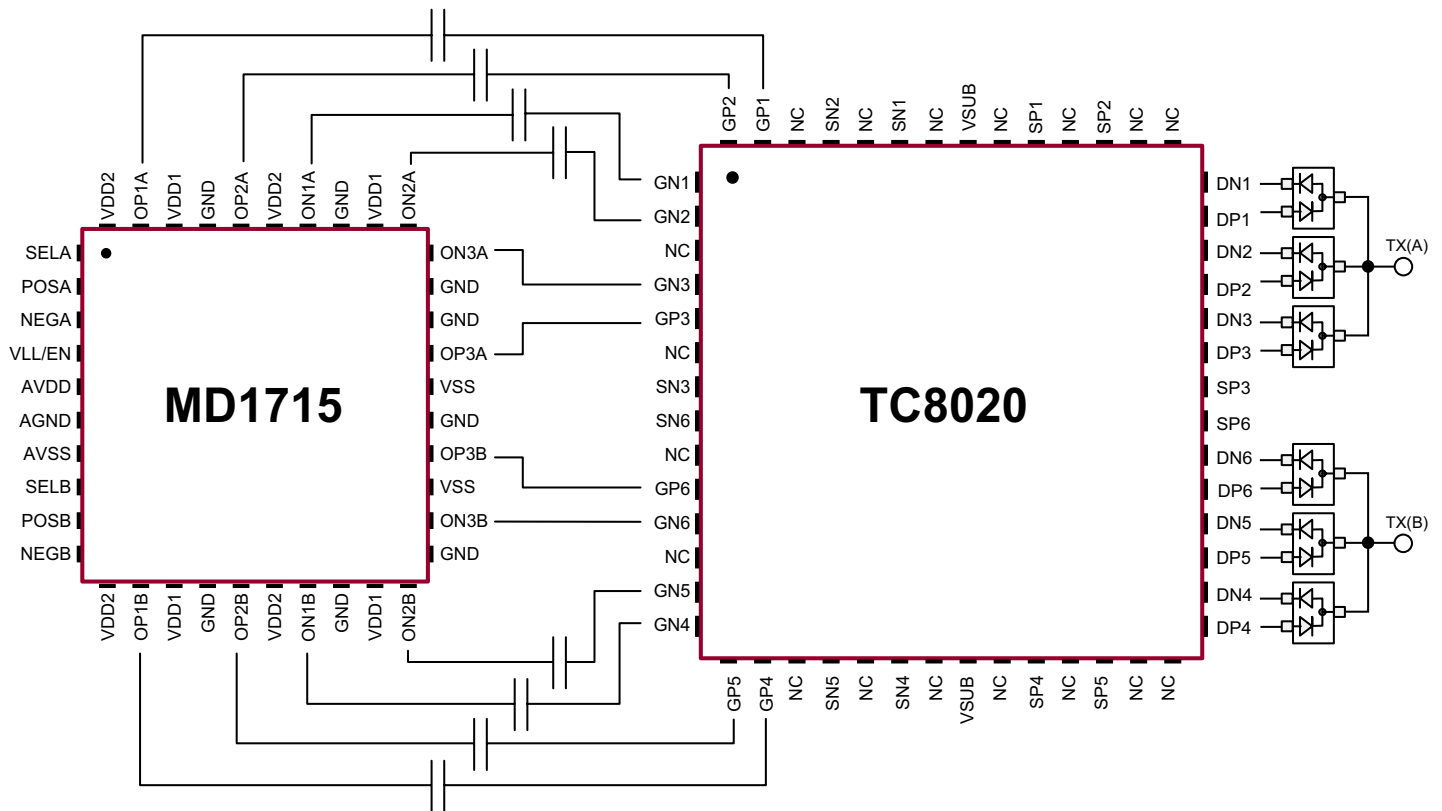

Timing Diagram

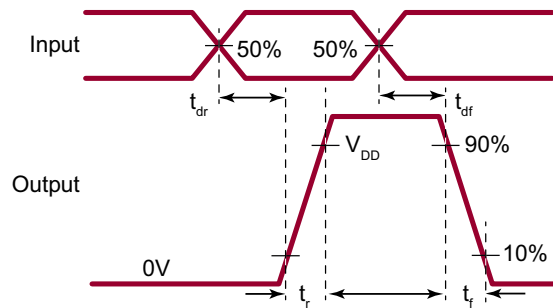

Detail Circuit

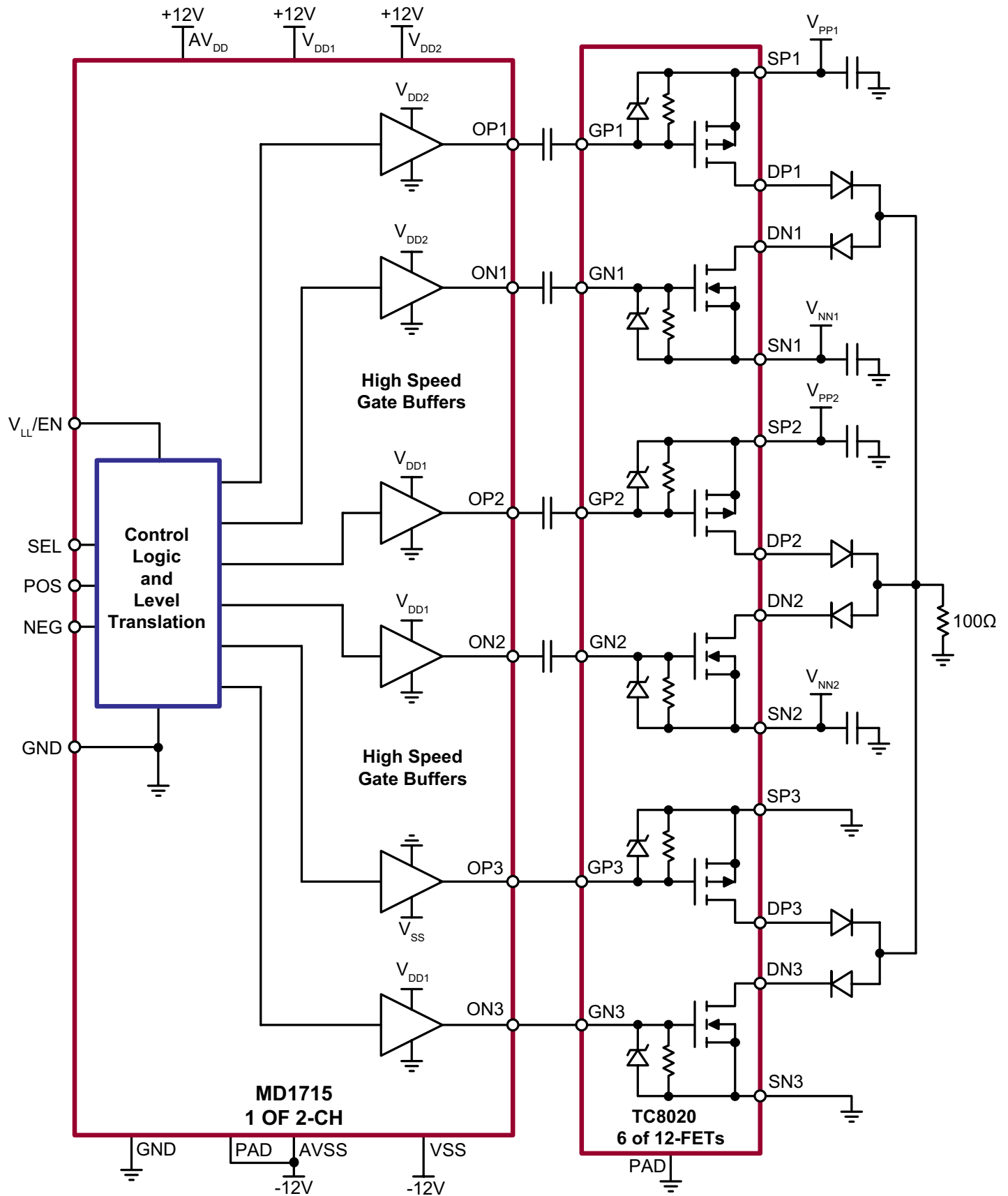

Pin Descriptions

Pin #	Name	Description
1	SELA	SEL input logic control for channel A. See logic truth table for details.
2	POSA	POS input logic control for channel A. See logic truth table for details.
3	NEGA	NEG input logic control for channel A. See logic truth table for details.
4	VLL/EN	Logic Hi reference voltage and chip enable input.
5	AVDD	Positive supply voltage of analog circuitry. AVDD should be same or higher potential than the highest voltages of VDD1 or VDD2.
6	AGND	Digital Ground.
7	AVSS	Negative supply voltage of analog circuitry and connection of IC substrate. Should be at the same potential as VSS.
8	SELB	SEL input logic control for channel B. See logic truth table for details.
9	POSB	POS input logic control for channel B. See logic truth table for details.
10	NEGB	NEG input logic control for channel B. See logic truth table for details.
11	VDD2	Positive supply voltage of the gate drivers for the output stage OP1, ON1 in A and B channels. VDD2 can be at a different voltage than VDD1.
12	OP1B	First output P-Channel gate drivers for channel B.
13	VDD1	Positive supply voltage of the gate drivers for the output stage for OP2, ON2, ON3 in A and B channels. VDD1 can be different voltage than VDD2.
14	GND	Power Ground.
15	OP2B	Second output P-Channel gate drivers for channel B.
16	VDD2	Positive supply voltage of the gate drivers for the output stage OP1, ON1 in A and B channels. VDD2 can be at a different voltage than VDD1.
17	ON1B	First output N-Channel gate drivers for channel B.
18	GND	Power Ground.
19	VDD1	Positive supply voltage of the gate drivers for the output stage for OP2, ON2, ON3 in A and B channels. VDD1 can be different voltage than VDD2.
20	ON2B	Second output N-Channel gate drivers for channel B.
21	GND	Power Ground.
22	ON3B	Damping output N-Channel gate drivers for channel B.
23	VSS	Negative supply voltage for gate drive of OP3. Should be the same voltage as AVSS.
24	OP3B	Damping output P-Channel gate drivers for channel B.
25	GND	Power Ground.
26	VSS	Negative supply voltage for gate drive of OP3. Should be the same voltage as AVSS.
27	OP3A	Damping output P-Channel gate drivers for channel A.
28	GND	Power Ground.
29	GND	Power Ground.
30	ON3A	Damping output N-Channel gate drivers for channel A.
31	ON2A	Second output N-Channel gate drivers for channel A.

Pin Descriptions (cont.)

Pin #	Name	Description
32	VDD1	Positive supply voltage of the gate drivers for the output stage for OP2, ON2, ON3 in A and B channels. VDD1 can be different voltage than VDD2.
33	GND	Power Ground.
34	ON1A	First output N-Channel gate drivers for channel A.
35	VDD2	Positive supply voltage of the gate drivers for the output stage OP1, ON1 in A and B channels. VDD2 can be at a different voltage than VDD1.
36	OP2A	Second output P-Channel gate drivers for channel A.
37	GND	Power Ground.
38	VDD1	Positive supply voltage of the gate drivers for the output stage for OP2, ON2, ON3 in A and B channels. VDD1 can be different voltage than VDD2.
39	OP1A	First output P-Channel gate drivers for channel A.
40	VDD2	Positive supply voltage of the gate drivers for the output stage OP1, ON1 in A and B channels. VDD2 can be at a different voltage than VDD1.
Center Pad	Thermal pad	IC substrate, must connect to AV_{SS} externally

40-Lead QFN Package Outline (K6)

6.00x6.00mm body, 1.00mm height (max), 0.50mm pitch

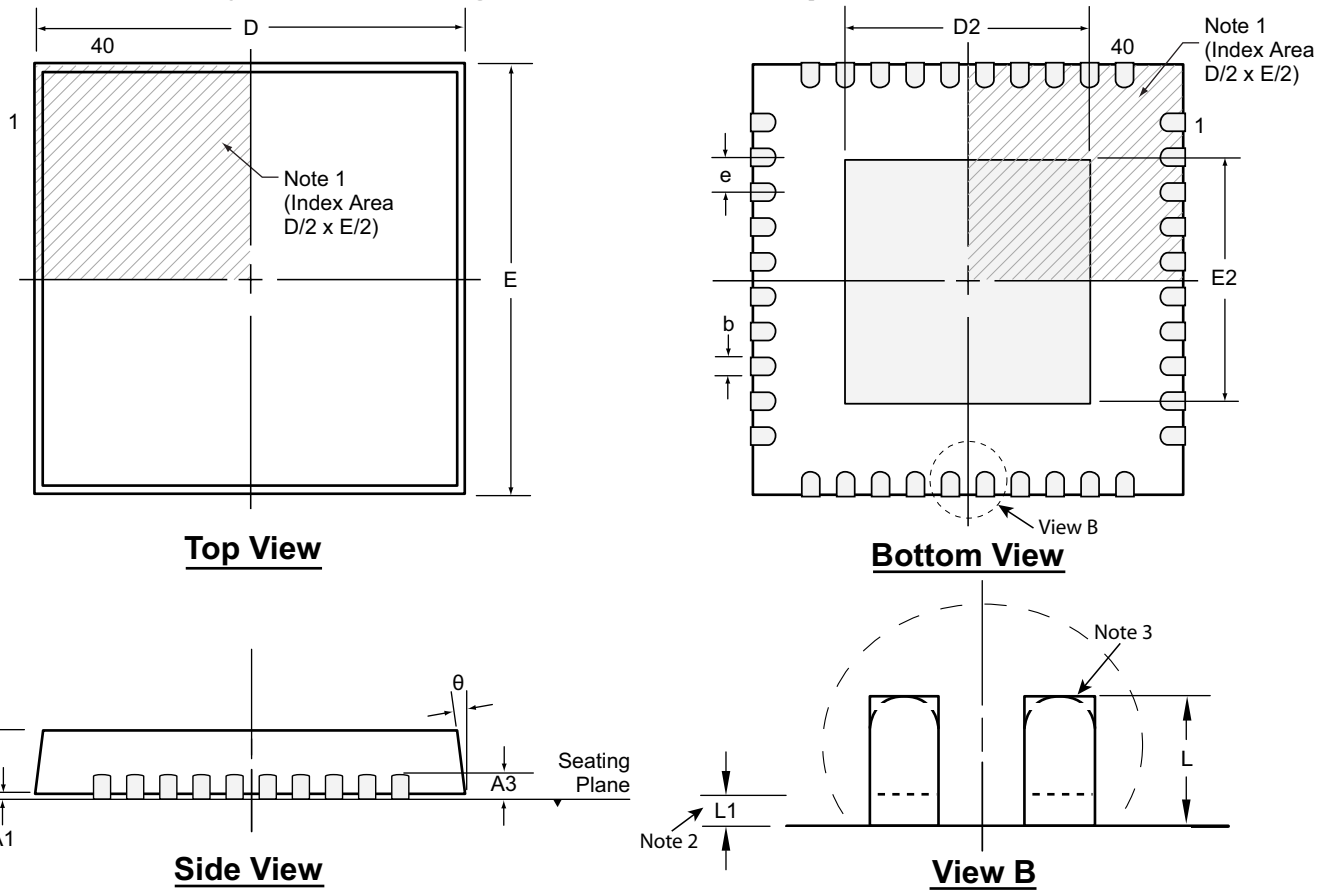

Notes:

1. A Pin 1 identifier must be located in the index area indicated. The Pin 1 identifier can be: a molded mark/identifier; an embedded metal marker; or a printed indicator.
2. Depending on the method of manufacturing, a maximum of 0.15mm pullback (L1) may be present.
3. The inner tip of the lead may be either rounded or square.

Symbol	A	A1	A3	b	D	D2	E	E2	e	L	L1	θ°	
Dimension (mm)	MIN	0.80	0.00	0.20 REF	0.18	5.85*	1.05	5.85*	1.05	0.50 BSC	0.30 [†]	0.00	0
	NOM	0.90	0.02		0.25	6.00	-	6.00	-		0.40 [†]	-	-
	MAX	1.00	0.05		0.30	6.15*	4.45	6.15*	4.45		0.50 [†]	0.15	14

JEDEC Registration MO-220, Variation VJJD-6, Issue K, June 2006.

* This dimension is not specified in the JEDEC drawing.

† This dimension differs from the JEDEC drawing.

Drawings not to scale.

Supertex Doc. #: DSPD-40QFNK66X6P050, Version C041009.

(The package drawing(s) in this data sheet may not reflect the most current specifications. For the latest package outline information go to <http://www.supertex.com/packaging.html>.)

Supertex inc. does not recommend the use of its products in life support applications, and will not knowingly sell them for use in such applications unless it receives an adequate "product liability indemnification insurance agreement." Supertex inc. does not assume responsibility for use of devices described, and limits its liability to the replacement of the devices determined defective due to workmanship. No responsibility is assumed for possible omissions and inaccuracies. Circuitry and specifications are subject to change without notice. For the latest product specifications refer to the Supertex inc. (website: <http://www.supertex.com>)

Компания «Океан Электроники» предлагает заключение долгосрочных отношений при поставках импортных электронных компонентов на взаимовыгодных условиях!

Наши преимущества:

- Поставка оригинальных импортных электронных компонентов напрямую с производств Америки, Европы и Азии, а так же с крупнейших складов мира;
- Широкая линейка поставок активных и пассивных импортных электронных компонентов (более 30 млн. наименований);
- Поставка сложных, дефицитных, либо снятых с производства позиций;
- Оперативные сроки поставки под заказ (от 5 рабочих дней);
- Экспресс доставка в любую точку России;
- Помощь Конструкторского Отдела и консультации квалифицированных инженеров;
- Техническая поддержка проекта, помощь в подборе аналогов, поставка прототипов;
- Поставка электронных компонентов под контролем ВП;
- Система менеджмента качества сертифицирована по Международному стандарту ISO 9001;
- При необходимости вся продукция военного и аэрокосмического назначения проходит испытания и сертификацию в лаборатории (по согласованию с заказчиком);
- Поставка специализированных компонентов военного и аэрокосмического уровня качества (Xilinx, Altera, Analog Devices, Intersil, Interpoint, Microsemi, Actel, Aeroflex, Peregrine, VPT, Syfer, Eurofarad, Texas Instruments, MS Kennedy, Miteq, Cobham, E2V, MA-COM, Hittite, Mini-Circuits, General Dynamics и др.);

Компания «Океан Электроники» является официальным дистрибьютором и эксклюзивным представителем в России одного из крупнейших производителей разъемов военного и аэрокосмического назначения «JONHON», а так же официальным дистрибьютором и эксклюзивным представителем в России производителя высокотехнологичных и надежных решений для передачи СВЧ сигналов «FORSTAR».



JONHON

«JONHON» (основан в 1970 г.)

Разъемы специального, военного и аэрокосмического назначения:

(Применяются в военной, авиационной, аэрокосмической, морской, железнодорожной, горно- и нефтедобывающей отраслях промышленности)

«FORSTAR» (основан в 1998 г.)

ВЧ соединители, коаксиальные кабели, кабельные сборки и микроволновые компоненты:

(Применяются в телекоммуникациях гражданского и специального назначения, в средствах связи, РЛС, а так же военной, авиационной и аэрокосмической отраслях промышленности).



Телефон: 8 (812) 309-75-97 (многоканальный)

Факс: 8 (812) 320-03-32

Электронная почта: ocean@oceanchips.ru

Web: <http://oceanchips.ru/>

Адрес: 198099, г. Санкт-Петербург, ул. Калинина, д. 2, корп. 4, лит. А