

### DESCRIPTION

The MP3387A is a step-up converter with 6-channel current sources designed to drive white LED arrays for backlighting in mid- to large-sized LCD panels.

The MP3387A uses peak-current mode as its PWM control architecture. The switching frequency can be programmed by a resistor. The MP3387M generates an output voltage up to 45V from a 3V-to-26V input supply. The MP3387A regulates the current in each LED string independently to the value set by an external current-setting resistor.

The MP3387A applies six internal current sources in each LED string terminal to achieve a current balance with 1.5% current regulation accuracy between strings. Its low 500mV regulation voltage on the LED current sources reduces power loss.

The MP3387A features external digital PWM dimming and analog dimming, both of which share a single input with a 25% PWM duty cycle as a transfer point. The mix-dimming strategy helps improve the dimming ratio. The MP3387A also transfers the PWM input signal from a 100Hz-to-20kHz frequency to 24kHz to 27.5kHz automatically to eliminate audible noise.

Full protection features include recoverable over-current protection (OCP), over-voltage protection (OVP), over-temperature protection (OTP), and short and open protection of any string on the LED.

The MP3387A is available in a TQFN-24 (4mmx4mm) package.

### FEATURES

- 6-String, Max 80mA/String
- 3V to 26V Input Voltage Range
- 1.5% Current Matching Accuracy between Strings
- Programmable Switching Frequency
- Selectable Combined Analog and PWM Dimming Mode or Direct PWM Dimming Mode
- Combined Analog and PWM Dimming Mode with 25% Dimming Transfer Point
- 24kHz to 27.5kHz Output Dimming Frequency to Eliminate Audible Noise
- Cascading Capability with a Single Power Source
- Programmable Over-Voltage Protection (OVP)
- Recoverable Thermal Shutdown Protection
- Cycle-by-Cycle Over-Current Protection (OCP)
- Under-Voltage Lockout (UVLO)
- Available in a TQFN-24 (4mmx4mm) Package

### APPLICATIONS

- Notebook PC
- Small LCD TV
- Handheld Terminal Display
- Automotive System and Tablet Computer

All MPS parts are lead-free, halogen-free, and adhere to the RoHS directive. For MPS green status, please visit the MPS website under Quality Assurance. "MPS" and "The Future of Analog IC Technology" are registered trademarks of Monolithic Power Systems, Inc.

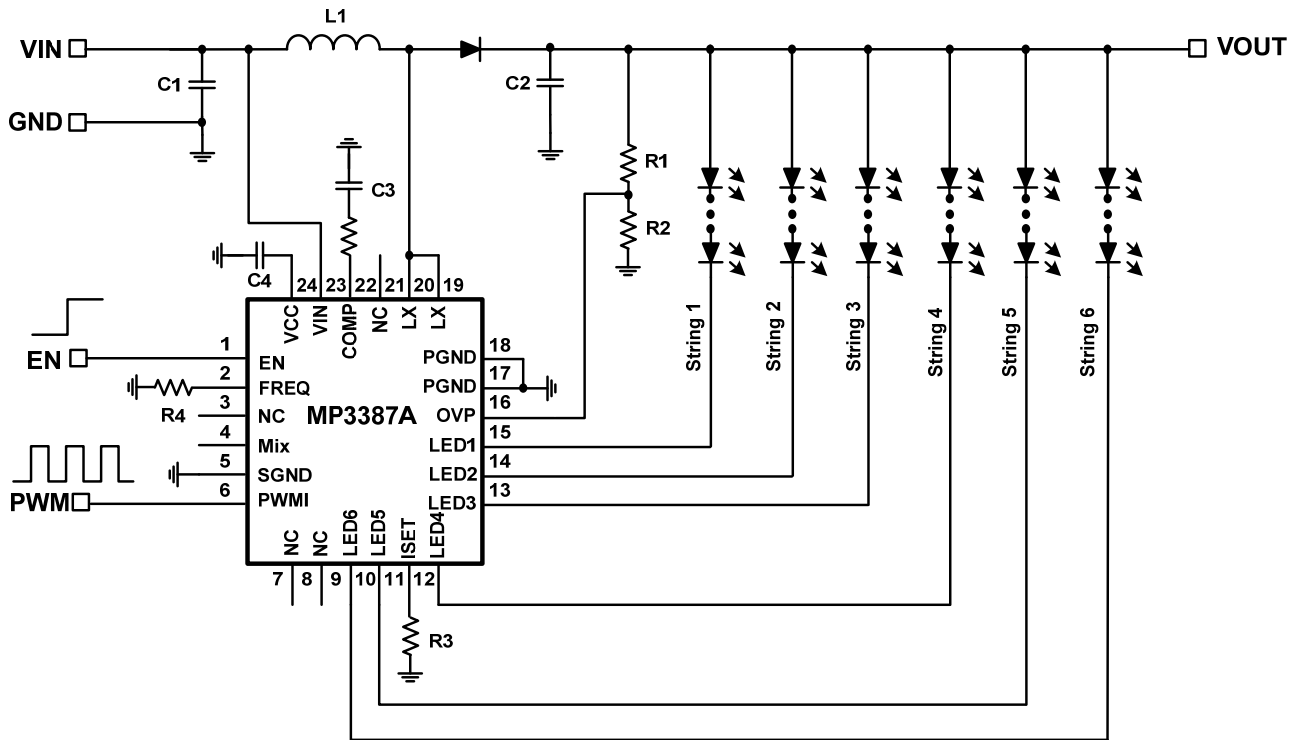
**TYPICAL APPLICATION**

### ORDERING INFORMATION

Part Number*	Package	Top Marking
MP3387AGRT	TQFN-24 (4mmx4mm)	See Below

\* For Tape & Reel, add suffix -Z (e.g. MP3387AGRT-Z)

### TOP MARKING

**MPSYWW**  
**M3387A**  
**LLLLLL**

MPS: MPS prefix  
 Y: Year code  
 WW: Week code  
 M3387A: Part number  
 LLLLLL: Lot number

### PACKAGE REFERENCE

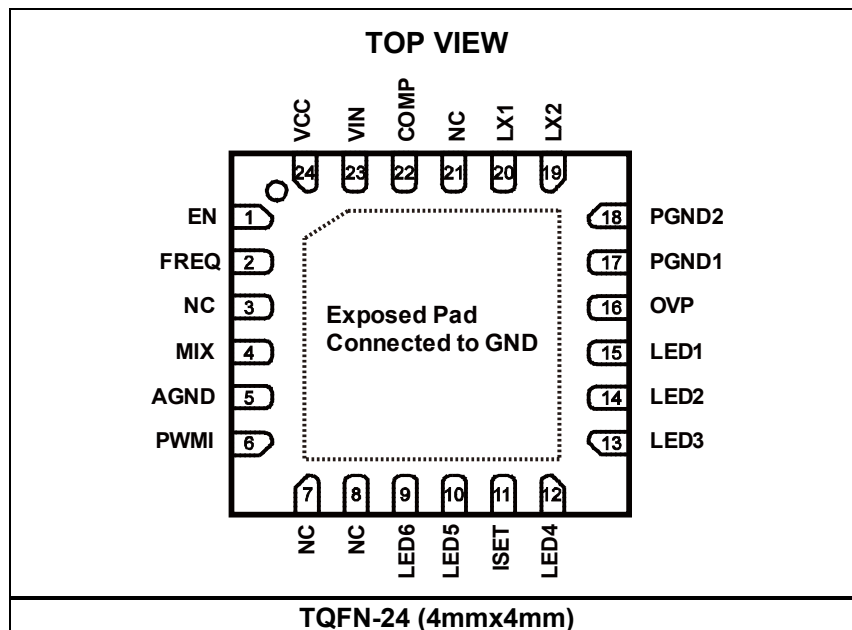

**ABSOLUTE MAXIMUM RATINGS** <sup>(1)</sup>

$V_{P\text{WMI}}, V_{\text{EN}}, V_{\text{IN}}$ .....	-0.3V to +30V
VCC .....	-0.3V to +6.5V
$V_{\text{LX}}, V_{\text{LED1}}$ to $V_{\text{LED6}}$ .....	-1V to +50V
All other pins .....	-0.3V to +6V
Junction temperature .....	150°C
Lead temperature .....	260°C
Continuous power dissipation ( $T_A = 25^\circ\text{C}$ ) <sup>(2)</sup>	
TQFN-24 (4mmx4mm).....	2.9W

**Recommended Operating Conditions** <sup>(3)</sup>

Supply voltage ( $V_{\text{IN}}$ ).....	3V to 26V
Operating junction temp.....	-40°C to +125°C

<b>Thermal Resistance</b> <sup>(4)</sup>	$\theta_{\text{JA}}$	$\theta_{\text{JC}}$	
TQFN-24 (4mmx4mm).....	42.....	9.....	°C/W

**NOTES:**

- 1) Exceeding these ratings may damage the device.
- 2) The maximum allowable power dissipation is a function of the maximum junction temperature  $T_{\text{J}}(\text{MAX})$ , the junction-to-ambient thermal resistance  $\theta_{\text{JA}}$ , and the ambient temperature  $T_{\text{A}}$ . The maximum allowable continuous power dissipation at any ambient temperature is calculated by  $P_{\text{D}}(\text{MAX}) = (T_{\text{J}}(\text{MAX}) - T_{\text{A}}) / \theta_{\text{JA}}$ . Exceeding the maximum allowable power dissipation produces an excessive die temperature, causing the regulator to go into thermal shutdown. Internal thermal shutdown circuitry protects the device from permanent damage.
- 3) The device is not guaranteed to function outside of its operating conditions.
- 4) Measured on JESD51-7, 4-layer PCB.

**ELECTRICAL CHARACTERISTICS**
 **$V_{IN} = 12V$ ,  $V_{EN} = 5V$ ,  $T_A = 25^{\circ}C$ , unless otherwise noted.**

Parameters	Symbol	Condition	Min	Typ	Max	Units
Operating input voltage	$V_{IN}$		3		26	V
Supply current (quiescent)	$I_Q$	$V_{IN} = 12V$ , $V_{EN} = 5V$ , no load		1.6		mA
Supply current (shutdown)	$I_{ST}$	$V_{EN} = 0V$ , $V_{IN} = 12V$			1	$\mu A$
LDO output voltage	$V_{CC}$	$V_{EN} = 5V$ , $6V < V_{IN} < 26V$ , $0 < I_{VCC} < 10mA$	4.5	5	5.5	V
VCC UVLO threshold	$V_{IN\_UVLO}$	Rising edge	2.4	2.55	2.7	V
VCC UVLO hysteresis				100		mV
EN on threshold	$V_{EN\_ON}$	$V_{EN}$ rising	1.5			V
EN off threshold	$V_{EN\_OFF}$	$V_{EN}$ falling			0.6	V
<b>Step-Up Converter</b>						
SW on resistance	$R_{DS(ON)}$	$I_{DS} = 20mA$		0.18	0.3	$\Omega$
SW leakage current	$I_{SW\_LK}$	$V_{SW} = 45V$			1	$\mu A$
Switching frequency	$F_{SW}$	$R_{FREQ} = 49.9k\Omega$	0.82	1.25	1.43	MHz
		$R_{FREQ} = 100k\Omega$	532	625	718	kHz
Maximum duty cycle	$D_{MAX}$		90	93	96	%
SW current limit	$I_{SW\_LIMIT}$	Duty = 90%	2	2.5		A
COMP transconductance	$G_{COMP}$	$\Delta I_{COMP} = \pm 10\mu A$		180		$\mu A/V$
COMP source current limit	$I_{COMP\_SOLI}$	$1V < COMP < 2.9V$		78		$\mu A$
COMP sink current limit	$I_{COMP\_SILI}$	$1V < COMP < 2.9V$		28		$\mu A$
<b>Current Dimming</b>						
PWMI input low threshold	$V_{PWMI\_LO}$	$V_{PWM}$ falling			0.4	V
PWMI input high threshold	$V_{PWMI\_HI}$	$V_{PWM}$ rising	1.5			V
MIX input low threshold	$V_{MIX\_LO}$	$V_{MIX}$ falling			0.4	V
MIX input high threshold	$V_{MIX\_HI}$	$V_{MIX}$ rising	1.5			V
PWMI dimming output frequency	$F_{PWMO}$		24		27.5	kHz
PWMI dimming input transfer point				25		%
PWMI dimming transfer point hysteresis				0.2		%
PWMI leakage current	$I_{PWMI\_LK}$	$V_{PWMI} = 5V$		10	15	$\mu A$
		$V_{PWMI} = 0V$			1	$\mu A$

**ELECTRICAL CHARACTERISTICS (continued)**
 $V_{IN} = 12V$ ,  $V_{EN} = 5V$ ,  $T_A = 25^{\circ}C$ , unless otherwise noted.

Parameters	Symbol	Condition	Min	Typ	Max	Units
<b>LED Current Regulation</b>						
LEDX average current	$I_{LED}$	$R_{ISET} = 62k\Omega$	19.7	20	20.3	mA
Current matching <sup>(5)</sup>		$I_{SET} = 20mA$			1.5	%
Maximum LED current per string	$I_{LEDmax}$		80			mA
ISET regulation voltage				1.24		V
LEDX regulation voltage	$V_{LEDX}$	$I_{LED} = 20mA$	400	500	600	mV
		$I_{LED} = 65mA$	720	820	920	mV
<b>Protection</b>						
Over-voltage protection threshold	$V_{OVP\_OV}$	Rising edge	1.16	1.2	1.24	V
OVP UVLO threshold	$V_{OVP\_UV}$	Step-up converter fails	50	80	110	mV
LEDX over-voltage threshold	$V_{LEDX\_OV}$	$V_{IN} > 5.5V$	5.1	5.5	5.9	V
LEDX UVLO threshold	$V_{LEDX\_UV}$		180	275	370	mV
Thermal shutdown threshold <sup>(6)</sup>	$T_{ST}$			150		$^{\circ}C$
Thermal shutdown hysteresis				20		$^{\circ}C$
LEDX over-voltage fault timer		$F_S = 1.25MHz$	1.3	1.6	1.9	ms

**NOTE:**

5) Matching is defined as the difference of maximum to minimum current divided by 2 times the setting current (for single IC).

6) Guaranteed by Design.

## TYPICAL PERFORMANCE CHARACTERISTICS

$V_{IN} = 12V$ , 10 LEDs in series, 6 strings, 20mA/string,  $T_A = 25^\circ C$ , unless otherwise noted.

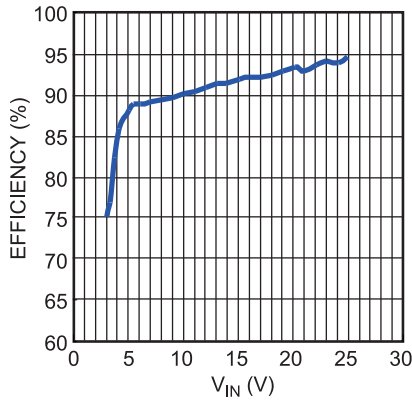
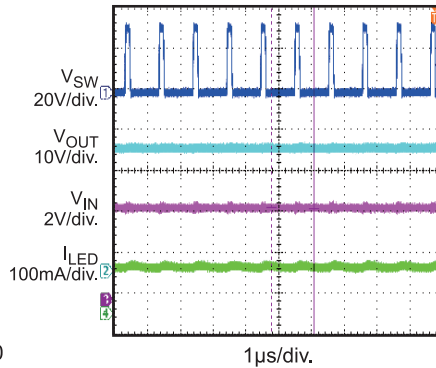
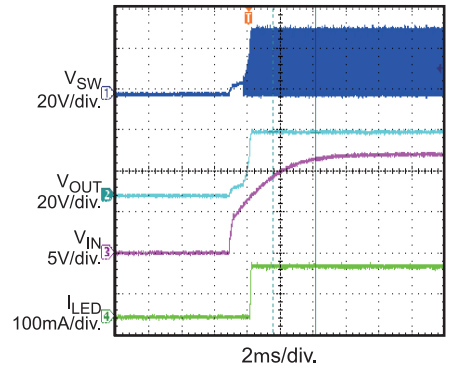
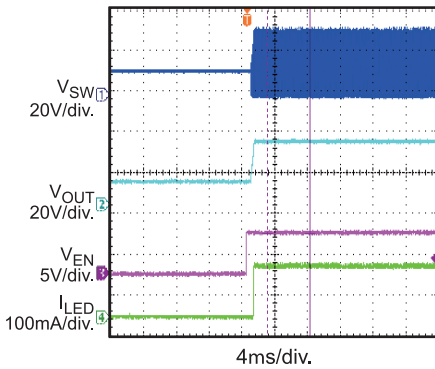
**Efficiency**

**Steady State**

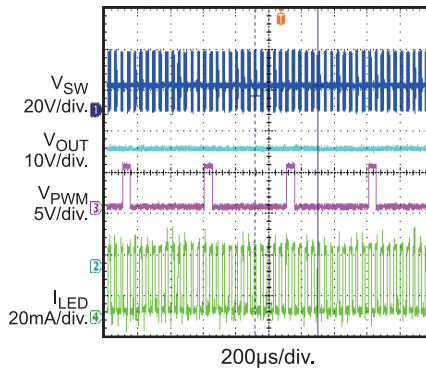
 **$V_{IN}$  Power On**

**EN Power On**

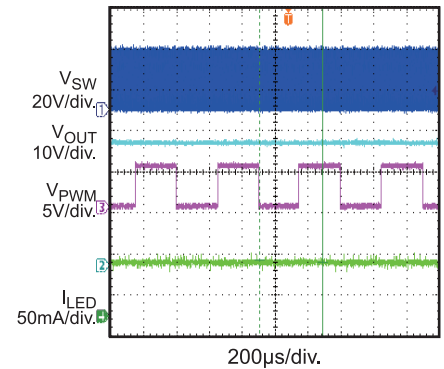
**Dimming in Mix Mode**

$f_{PWM} = 2kHz$ ,  $D_{PWM} = 10\%$

**Dimming in Mix Mode**

$f_{PWM} = 2kHz$ ,  $D_{PWM} = 50\%$

**Dimming in External PWM Mode**

$f_{PWM} = 2kHz$ ,  $D_{PWM} = 50\%$

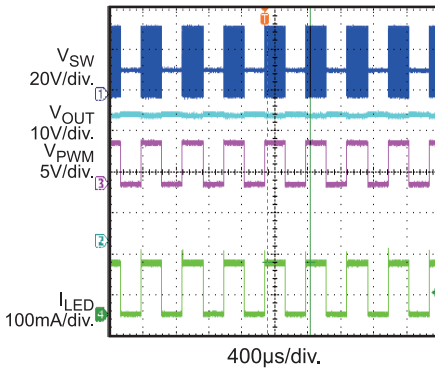
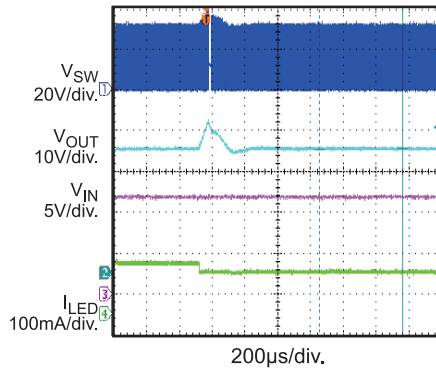
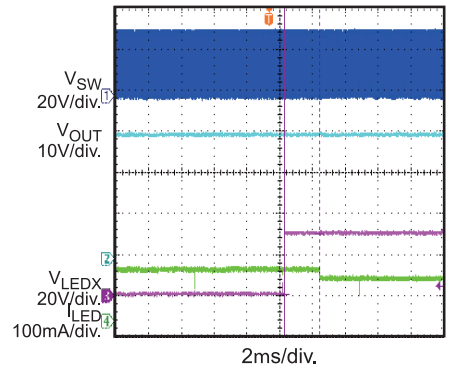
**Open LED Protection**

**Short LED Protection**

## PIN FUNCTIONS

Package Pin #	Name	Description
1	EN	<b>Enable control input.</b> EN is weakly pulled low internally.
2	FREQ	<b>Switching frequency setting.</b> Connect a resistor between FREQ and GND to set the converter's switching frequency.
3, 7, 8, 21	NC	<b>No connection.</b> Leave NC floating.
4	MIX	<b>Dimming mode selection.</b> Pull MIX high to select combined analog and PWM dimming mode with a 25% transfer point. Pull MIX low to select direct PWM dimming mode. MIX is pulled high by default.
5	AGND	<b>Analog ground.</b>
6	PWMI	<b>PWM signal input.</b> Apply a PWM signal on PWMI for brightness control. A 100Hz to 20kHz dimming signal is recommended. PWMI is weakly pulled low internally.
9	LED6	<b>LED string 6 current input.</b> LED6 is the open-drain output of an internal dimming control switch. Connect the LED string 6 cathode to LED6.
10	LED5	<b>LED string 5 current input.</b> LED5 is the open-drain output of an internal dimming control switch. Connect the LED string 5 cathode to LED5.
11	ISET	<b>LED current setting.</b> Tie a current setting resistor from ISET to GND to program the current in each LED string.
12	LED4	<b>LED string 4 current input.</b> LED4 is the open-drain output of an internal dimming control switch. Connect the LED string 4 cathode to LED4.
13	LED3	<b>LED string 3 current input.</b> LED3 is the open-drain output of an internal dimming control switch. Connect the LED string 3 cathode to LED3.
14	LED2	<b>LED string 2 current input.</b> LED2 is the open-drain output of an internal dimming control switch. Connect the LED string 2 cathode to LED2.
15	LED1	<b>LED string 1 current input.</b> LED1 is the open-drain output of an internal dimming control switch. Connect the LED string 1 cathode to LED1.
16	OVP	<b>Over-voltage protection input.</b> Connect a resistor divider from the output to OVP to program the OVP threshold.
17	PGND1	<b>Step-up converter power ground.</b> PGND1 and PGND2 should be shorted externally.
18	PGND2	<b>Step-up converter power ground.</b> PGND2 and PGND1 should be shorted externally.
19	LX2	<b>Step-up converter power switch output.</b> LX2 is the drain of the internal MOSFET switch. Connect the power inductor and output rectifier to LX2. LX2 and LX1 should be shorted externally.
20	LX1	<b>Step-up converter power switch output.</b> LX1 is the drain of the internal MOSFET switch. Connect the power inductor and output rectifier to LX1. LX1 and LX2 should be shorted externally.
22	COMP	<b>Step-up converter compensation.</b> COMP is used to compensate the regulation control loop. Connect a capacitor or a series R-C network from COMP to GND.
23	VIN	<b>Power supply input.</b> VIN supplies power to the IC. Drive VIN with a 3V to 26V power source. VIN must be bypassed locally.
24	VCC	<b>Internal 5V linear regulator output.</b> VCC provides a power supply for the internal MOSFET switch gate driver and the internal control circuitry. Bypass VCC to GND with a ceramic capacitor. If VIN is less than 5.5V, tie VIN and VCC together.



# BLOCK DIAGRAM

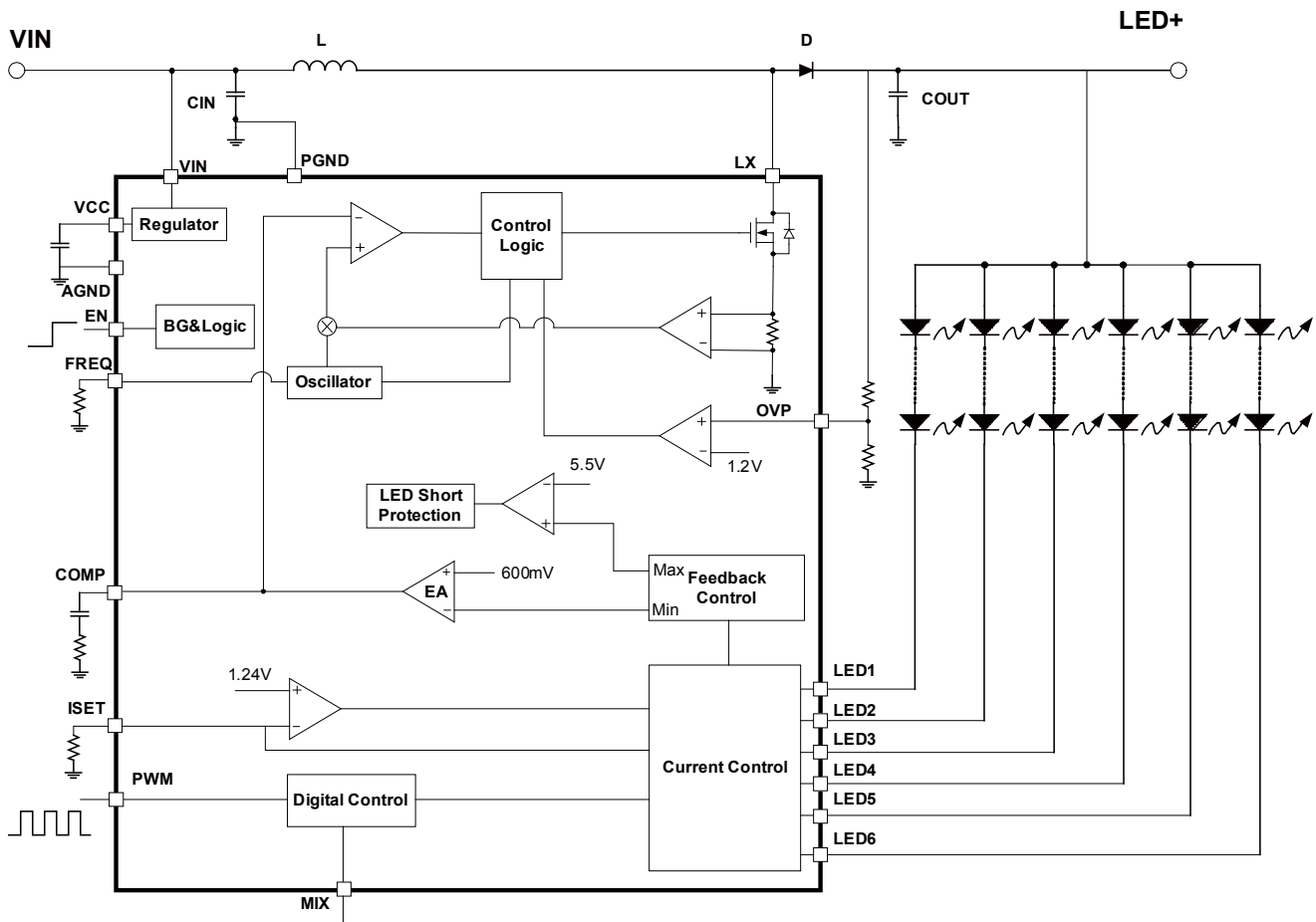

Figure 1: Functional Block Diagram

## OPERATION

The MP3387A employs a peak current as its PWM mode architecture and has 6-channel current sources to regulate the array of 6-string white LEDs.

### Internal 5V Regulator

The MP3387A includes an internal linear regulator (VCC). When VIN is greater than 5.5V, this regulator offers a 5V power supply for the internal MOSFET switch-gate driver and the internal control circuitry. The VCC voltage drops to 0V when the chip shuts down. If VIN is smaller than 5.5V, tie VCC and VIN together. The MP3387A features under-voltage lockout (UVLO), which disables the chip until VCC exceeds the UVLO threshold. The hysteresis of UVLO is 100mV, approximately.

### System Start-Up

When enabled, the MP3387A checks the topology connection first. The chip monitors the over-voltage protection (OVP) pin to determine whether the Schottky diode is connected or whether the boost output is shorted to GND. An OVP voltage less than 80mV will fail to switch. The MP3387A also checks other safety limits, including UVLO and over-temperature protection (OTP). If detections of all protections pass, the chip then begins boosting the step-up converter with an internal soft start.

It is recommended that the enable signal occur after the establishment of the input voltage and PWM dimming signal during the start-up sequence to prevent a large inrush current.

### Step-Up Converter

The converter operating frequency is programmed with an external resistor connected to OSC. This helps optimize efficiency and the size of the external components.

At the beginning of each switching cycle, the internal clock turns on the low side MOSFET. In normal operation, the minimum turn-on time is 100ns. A stabilizing ramp added to the output of the current sense amplifier prevents subharmonic oscillations for duty cycles greater than 50%. This result is fed into the PWM comparator. When this resulting voltage reaches the output voltage of the error amplifier (V<sub>COMP</sub>), the low side MOSFET turns off.

The output voltage of the internal error amplifier is an amplified signal of the difference between the reference voltage and the feedback voltage. The converter chooses the lowest active LEDX pin voltage automatically to provide a bus voltage high enough to power all of the LED arrays.

If the feedback voltage drops below the reference, the output of the error amplifier increases. This results in more current flowing through the MOSFET, which increases the power delivered to the output. This forms a closed loop that regulates the output voltage.

Under light-load operation, especially in the case of  $V_{OUT} \approx V_{IN}$ , the converter runs in pulse-skipping mode. In this mode, the MOSFET turns on for a minimum on-time of approximately 100ns, and then the converter discharges the power to the output for the remaining period. The low side MOSFET remains off until the output voltage needs to be boosted again.

### Dimming Control

The MP3387A provides two dimming methods: direct PWM dimming mode or combined analog and PWM dimming mode.

If MIX is pulled high, the MP3387A works in combined analog and PWM dimming mode with 25% as its transfer point. By default, MIX is pulled high. A PWM signal is applied to PWMI.

When the duty cycle of the PWM dimming signal is  $\geq 25\%$ , the IC dims the LED current with analog mode and the LED current amplitude is equal to  $I_{SET} * D_{DIM}$  (where  $I_{SET}$  is the LED current set by the resistor connected to ISET, and  $D_{DIM}$  is the duty cycle of PWM dimming signal). Analog dimming helps reduce LED power loss and prevent audible noise issues.

When the duty cycle of the PWM dimming signal is  $< 25\%$ , the IC dims the LED current in PWM mode. The LED current amplitude is fixed at  $25\% * I_{SET}$ , while the LED dimming duty is four times  $D_{DIM}$  to make the actual average LED current equal to  $I_{SET} * D_{DIM}$ . The actual LED current dimming frequency is switched automatically from 100Hz ~ 20kHz to 24kHz ~ 27.5kHz of the input PWM dimming signal frequency. By doing this, the MP3387A

improves the low LED current dimming ratio and prevents troublesome audible noise issues.

If MIX is pulled low, the MP3387A works with direct PWM dimming mode. The LED current is fixed to  $I_{SET}$ , and the output LED current is chopped following the direct PWM dimming signal duty cycle and frequency. The average output current is equal to  $I_{SET} * D_{DIM}$ .

### Output Over-Voltage Protection and Short Protection

In some unexpected cases, to prevent the IC from continuing to charge the output voltage, the MP3387A uses an OVP function to protect the components from being damaged by the output voltage. If the OVP high-protection threshold point (1.2V) has been reached, the chip stops switching and the output voltage drops. Switching resumes if the OVP point drops below the recovery threshold.

The MP3387A can also achieve an output short to GND or diode open protection by detecting the OVP voltage. The IC works in normal switching mode only when the OVP voltage is higher than 80mV.

### Open-String Protection

Open-string protection is achieved by detecting both the OVP pin and the LED (1 to 6) pins. If one or more strings (but not all strings) are open, the respective LEDX pins are pulled to ground, and the IC continues charging the output voltage until OVP reaches the 1.2V protection threshold. The chip stops switching and marks off the open strings that have an LEDX pin voltage lower than 275mV. Once marked, the remaining LED strings force the output voltage back into the correct regulation. The string with the largest voltage drop determines the output regulation. The marked-off strings can resume normal operation after they are connected back to the system.

If all six strings are open (LED bar is open), the IC continues charging the output voltage until the OVP voltage reaches the 1.2V threshold and marks off the LED current regulator. The IC resumes normal current regulation until VIN or EN is reset.

### Short-String Protection

The MP3387A monitors the LEDX pin voltage to determine if a short string occurs. If one or more strings are short, the respective LEDX pins are pulled up to the boost output and tolerate high-voltage stress. If the LEDX pin voltage is higher than 5.5V, the short-string condition is detected on the respective string. When the short-string fault (LEDX over-voltage fault) continues for longer than 1.6ms ( $f_{sw}=1.25\text{MHz}$ ), the corresponding string current regulator is disabled and disconnects from the output voltage loop regulation. The LED string resumes normal current regulation when the short condition is removed.

### Thermal Shutdown

To prevent the IC from operating at exceedingly high temperatures, thermal shutdown is implemented by detecting the silicon die temperature. When the die temperature exceeds the upper threshold ( $T_{ST}$ ), the IC shuts down and resumes normal operation when the die temperature drops below the lower threshold. Typically, the hysteresis value is 20°C.

## APPLICATION INFORMATION

### Selecting the Switching Frequency

The switching frequency of the step-up converter is recommended to be between 500kHz and 1.2MHz for most applications. An oscillator resistor on **FREQ** sets the internal oscillator frequency for the step-up converter according to Equation (1):

$$f_{sw}(kHz) = \frac{62500}{R_{osc}(k\Omega)} \quad (1)$$

For  $R_{osc} = 100k\Omega$ , the switching frequency is 625kHz.

### Setting the LED Current

The current of each string is identical and set through the current setting resistor on **ISET**, which can be calculated with Equation (2):

$$I_{SET} = 1000 \times \frac{1.24(V)}{R_{SET}(k)} \quad (2)$$

For  $R_{SET} = 62k\Omega$ , the LED current is 20mA. **ISET** cannot be open.

### Selecting the Input Capacitor

The input capacitor reduces surge current drawn from the input supply and switching noise from the device. The input capacitor impedance at the switching frequency should be less than the input source impedance to prevent the high-frequency switching current from passing through to the input. Use ceramic capacitors with X5R or X7R dielectrics for their low ESR and small temperature coefficients. For most applications, a 4.7 $\mu$ F ceramic capacitor is sufficient.

### Selecting the Inductor

The MP3387A requires an inductor to supply a higher output voltage while being driven by the input voltage. A larger-value inductor results in less ripple current, lower peak inductor current, and less stress on the internal N-channel MOSFET. However, the larger-value inductor also has a larger physical size, higher series resistance, and lower saturation current.

Choose an inductor that will not saturate under worst-case load conditions. Select the minimum inductor value to ensure that the boost converter works in continuous conduction mode with high efficiency and good EMI performance.

Calculate the required inductance value using Equation (3) and Equation (4):

$$L \geq \frac{\eta \times V_{OUT} \times D \times (1-D)^2}{2 \times f_{sw} \times I_{LOAD}} \quad (3)$$

$$D = 1 - \frac{V_{IN}}{V_{OUT}} \quad (4)$$

Where  $V_{IN}$  is the input voltage,  $V_{OUT}$  is the output voltage,  $f_{sw}$  is the switching frequency,  $I_{LOAD}$  is the LED load current, and  $\eta$  is the efficiency.

With a given inductor value, the inductor DC current rating is at least 40% higher than the maximum input peak inductor current for most applications. The inductor's DC resistance should be as small as possible to achieve a higher efficiency.

### Selecting the Output Capacitor

The output capacitor keeps the output voltage ripple small and ensures feedback loop stability. The output capacitor impedance must be low at the switching frequency. Ceramic capacitors with X7R dielectrics are recommended for their low ESR characteristics. For most applications, a 2.2 $\mu$ F ceramic capacitor is sufficient.

### Setting the Over-Voltage Protection

Open-string protection is achieved through the detection of the voltage on **OVP**. In some unexpected cases, the part continues boosting the output voltage higher and higher. If the output voltage reaches the programmed **OVP** threshold, the protection triggers.

To ensure that the chip functions properly, select the resistor values for the **OVP** resistor divider to provide an appropriate set voltage. The recommended **OVP** point is about 1.1 to 1.2 times higher than the output voltage for normal operation. The **OVP** voltage can be calculated with Equation (5):

$$V_{OVP} = 1.2(V) \times \left(1 + \frac{R_{HIGH}}{R_{LOW}}\right) \quad (5)$$

### Selecting the Dimming Control Mode

The MP3387A provides two different dimming methods: direct PWM dimming and combined analog and PWM dimming.

#### 1) Direct PWM Dimming

Pull MIX low to operate the MP3387A in direct PWM dimming mode. Apply a PWM dimming signal to PWMI. The LED current is fixed to  $I_{SET}$ . The output LED current is chopped following the direct PWM dimming signal duty cycle and frequency. The average output current is equal to  $I_{SET} * D_{DIM}$ . The input PWM dimming frequency depends on the LED current dimming ratio. A lower input PWM dimming frequency results in a better LED dimming ratio. Usually, a 200Hz to 2kHz PWM signal is sufficient for most applications.

#### 2) Combined Analog and PWM Dimming

Pull MIX high to operate the MP3387A in combined analog and PWM dimming mode with 25% as its transfer point. In default, MIX is pulled high. A PWM signal is applied to PWMI. When the duty cycle of the PWM dimming signal is  $\geq 25\%$ , the IC dims the LED current with analog mode, and the LED current amplitude is equal to  $I_{SET} * D_{DIM}$  (where  $I_{SET}$  is the LED current set by resistor connected to ISET, and  $D_{DIM}$  is the duty cycle of PWM dimming signal). Analog dimming helps reduce LED power loss and prevent audible noise issues. When the duty cycle of the PWM dimming signal is  $< 25\%$ , the IC dims the LED current in PWM mode. The LED current amplitude is fixed to  $25\% * I_{SET}$ , while the LED dimming duty is four times  $D_{DIM}$  to make the actual average LED current equal to  $I_{SET} * D_{DIM}$ .

The actual LED current dimming frequency is switched automatically from 100Hz ~ 20kHz to 24kHz ~ 27.5kHz of the input PWM dimming signal frequency. By doing this, the MP3387A can improve the low LED current dimming ratio and prevent troublesome audible noise issues.

### PCB Layout Guidelines

Careful attention must be paid to the PCB board layout and component placement. Proper layout of the high frequency switching path is critical to prevent noise and electromagnetic interference problems. For best results, refer to Figure 2 and follow the guidelines below.

1. Keep the loop of LX to PGND (U1), the output diode (D1), and the output capacitor (C2) as short as possible, since it is flowing with high frequency pulse current.
2. Connect the IC's exposed pad to GND internally.
3. Refer all logic signals to GND.
4. Connect PGND to GND externally.
5. Keep PGND away from the logic signals.

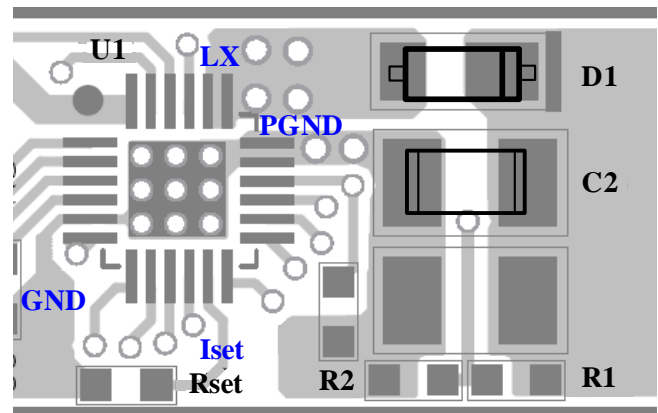

**Figure 2: Recommended Layout**

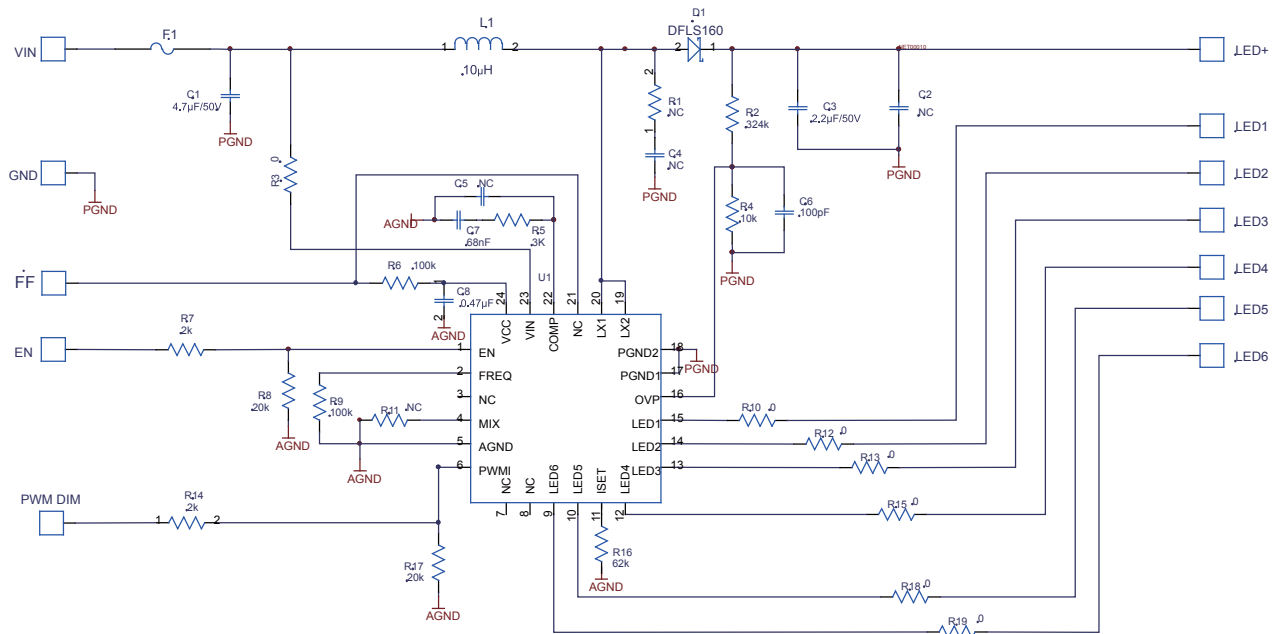
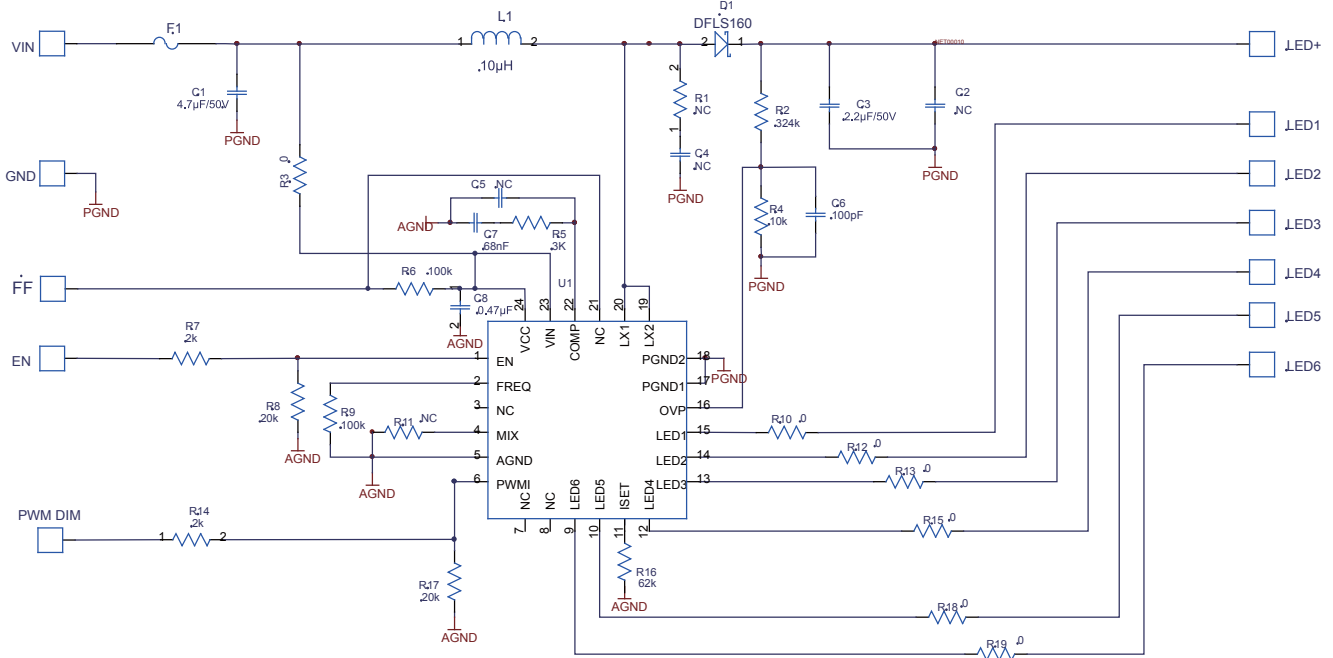
**TYPICAL APPLICATION CIRCUITS**

**Figure 3: VIN > 5.5V, 6-String, 20mA/String Application**

**Figure 4: VIN < 5.5V, 6-String, 20mA/String Application (tie VIN and VCC together)**



TYPICAL APPLICATION CIRCUITS (continued)

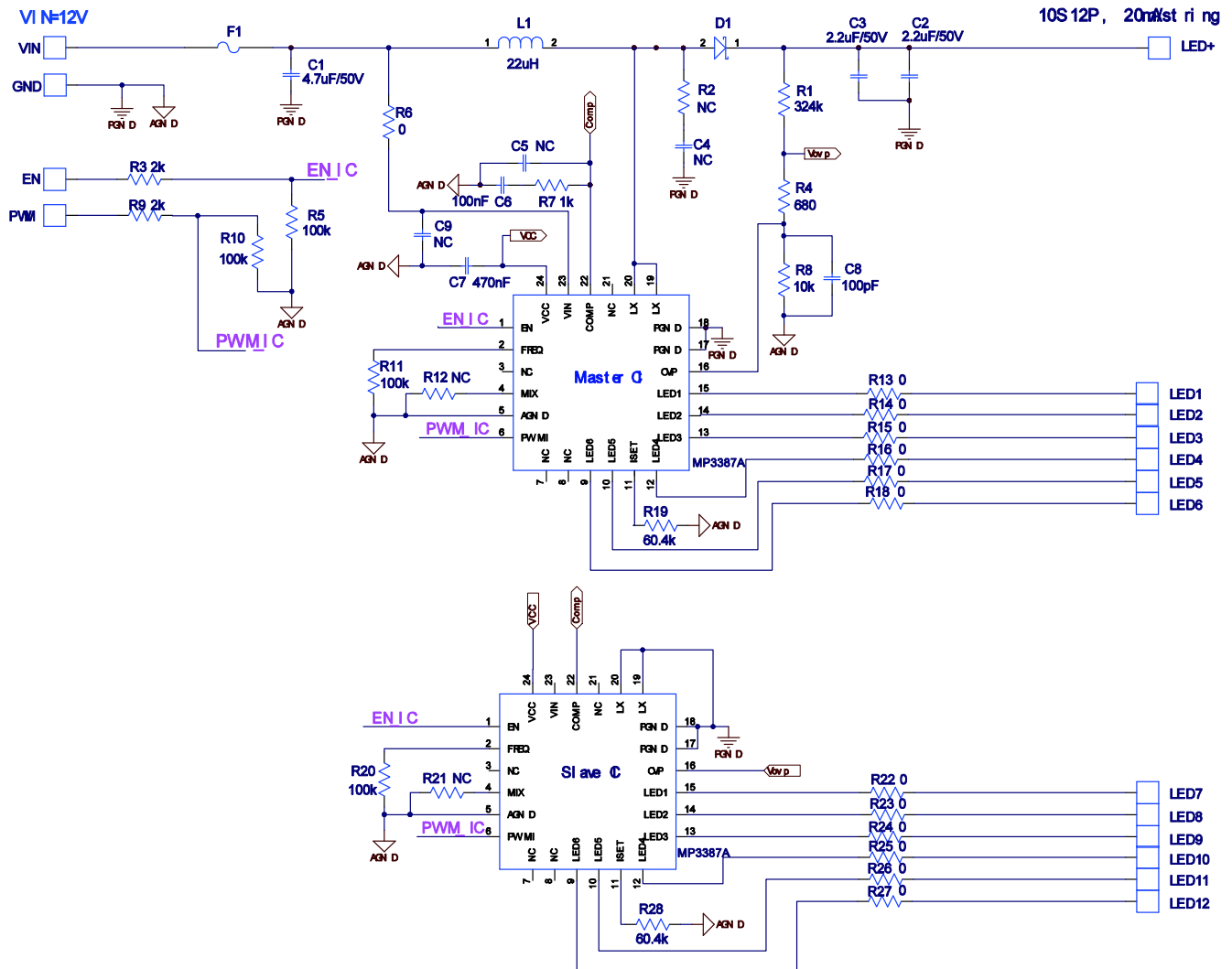
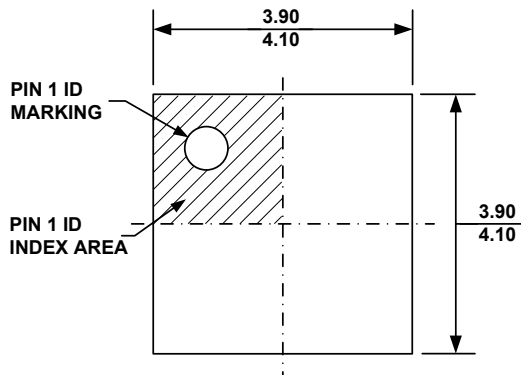

Figure 5: Driving 12 LED Strings with a Single Power (Cascade Structure)

NOTE: Some components are reasonably adjustable based on real cases.

# PACKAGE INFORMATION

## TQFN-24 (4mmX4mm)



**TOP VIEW**

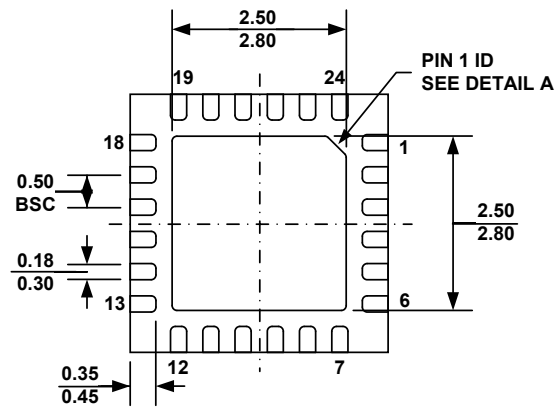

**BOTTOM VIEW**

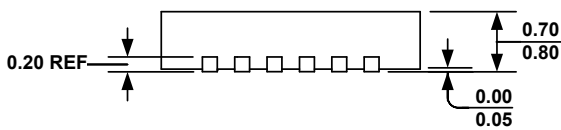

**SIDE VIEW**

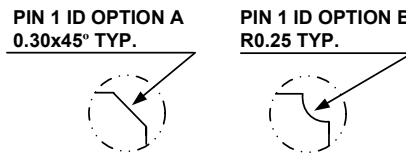

**DETAIL A**

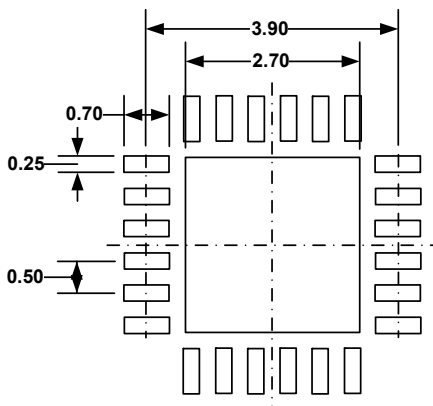

**RECOMMENDED LAND PATTERN**

**NOTE:**

- 1) ALL DIMENSIONS ARE IN MILLIMETERS.
- 2) EXPOSED PADDLE SIZE DOES NOT INCLUDE MOLD FLASH.
- 3) LEAD COPLANARITY SHALL BE 0.10 MILLIMETER MAX.
- 4) DRAWING CONFIRMS TO JEDEC MO-220, VARIATION WGGD.
- 5) DRAWING IS NOT TO SCALE.

**NOTICE:** The information in this document is subject to change without notice. Please contact MPS for current specifications. Users should warrant and guarantee that third party Intellectual Property rights are not infringed upon when integrating MPS products into any application. MPS will not assume any legal responsibility for any said applications.



Компания «Океан Электроники» предлагает заключение долгосрочных отношений при поставках импортных электронных компонентов на взаимовыгодных условиях!

Наши преимущества:

- Поставка оригинальных импортных электронных компонентов напрямую с производств Америки, Европы и Азии, а так же с крупнейших складов мира;
- Широкая линейка поставок активных и пассивных импортных электронных компонентов (более 30 млн. наименований);
- Поставка сложных, дефицитных, либо снятых с производства позиций;
- Оперативные сроки поставки под заказ (от 5 рабочих дней);
- Экспресс доставка в любую точку России;
- Помощь Конструкторского Отдела и консультации квалифицированных инженеров;
- Техническая поддержка проекта, помощь в подборе аналогов, поставка прототипов;
- Поставка электронных компонентов под контролем ВП;
- Система менеджмента качества сертифицирована по Международному стандарту ISO 9001;
- При необходимости вся продукция военного и аэрокосмического назначения проходит испытания и сертификацию в лаборатории (по согласованию с заказчиком);
- Поставка специализированных компонентов военного и аэрокосмического уровня качества (Xilinx, Altera, Analog Devices, Intersil, Interpoint, Microsemi, Actel, Aeroflex, Peregrine, VPT, Syfer, Eurofarad, Texas Instruments, MS Kennedy, Miteq, Cobham, E2V, MA-COM, Hittite, Mini-Circuits, General Dynamics и др.);

Компания «Океан Электроники» является официальным дистрибьютором и эксклюзивным представителем в России одного из крупнейших производителей разъемов военного и аэрокосмического назначения «JONHON», а так же официальным дистрибьютором и эксклюзивным представителем в России производителя высокотехнологичных и надежных решений для передачи СВЧ сигналов «FORSTAR».



## JONHON

«JONHON» (основан в 1970 г.)

Разъемы специального, военного и аэрокосмического назначения:

(Применяются в военной, авиационной, аэрокосмической, морской, железнодорожной, горно- и нефтедобывающей отраслях промышленности)

«FORSTAR» (основан в 1998 г.)

ВЧ соединители, коаксиальные кабели,  
кабельные сборки и микроволновые компоненты:

(Применяются в телекоммуникациях гражданского и специального назначения, в средствах связи, РЛС, а так же военной, авиационной и аэрокосмической отраслях промышленности).



Телефон: 8 (812) 309-75-97 (многоканальный)

Факс: 8 (812) 320-03-32

Электронная почта: [ocean@oceanchips.ru](mailto:ocean@oceanchips.ru)

Web: <http://oceanchips.ru/>

Адрес: 198099, г. Санкт-Петербург, ул. Калинина, д. 2, корп. 4, лит. А