

256-Kbit (32 K × 8) Serial (I²C) nvSRAM with Real Time Clock

Features

- 256-Kbit nonvolatile static random access memory (nvSRAM)
 - Internally organized as 32 K × 8
 - STORE to QuantumTrap nonvolatile elements initiated automatically on power-down (AutoStore) or by using I²C command (Software STORE) or HSB pin (Hardware STORE)
 - RECALL to SRAM initiated on power-up (Power-Up RECALL) or by I²C command (Software RECALL)
 - Automatic STORE on power-down with a small capacitor
- High reliability
 - Infinite read, write, and RECALL cycles
 - 1 million STORE cycles to QuantumTrap
 - Data retention: 20 years at 85 °C
- Real Time Clock (RTC)
 - Full-featured RTC
 - Watchdog timer
 - Clock alarm with programmable interrupts
 - Backup power fail indication
 - Square wave output with programmable frequency (1 Hz, 512 Hz, 4096 Hz, 32.768 kHz)
 - Capacitor or battery backup for RTC
 - Backup current of 0.45 μA (typical)
- High-speed I²C interface^[1]
 - Industry standard 100 kHz and 400 kHz speed
 - Fast mode Plus 1 MHz speed
 - High speed: 3.4 MHz
 - Zero cycle delay reads and writes
- Write protection
 - Hardware protection using Write Protect (WP) pin
 - Software block protection for one-quarter, one-half, or entire array
- I²C access to special functions
 - Nonvolatile STORE/RECALL
 - 8-byte serial number
 - Manufacturer ID and Product ID
 - Sleep mode
- Low power consumption
 - Average active current of 1 mA at 3.4 MHz operation
 - Average standby mode current of 250 μA
 - Sleep mode current of 8 μA
- Industry standard configurations
 - Operating voltages:
 - CY14C256I: V_{CC} = 2.4 V to 2.6 V
 - CY14B256I: V_{CC} = 2.7 V to 3.6 V
 - CY14E256I: V_{CC} = 4.5 V to 5.5 V
 - Industrial temperature
 - 16-pin small outline integrated circuit (SOIC) package
 - Restriction of hazardous substances (RoHS) compliant

Overview

The Cypress CY14C256I/CY14B256I/CY14E256I combines a 256-Kbit nvSRAM^[2] with a full-featured RTC in a monolithic integrated circuit with serial I²C interface. The memory is organized as 64 K words of 8 bits each. The embedded nonvolatile elements incorporate the QuantumTrap technology, creating the world's most reliable nonvolatile memory. The SRAM provides infinite read and write cycles, while the QuantumTrap cells provide highly reliable nonvolatile storage of data. Data transfers from SRAM to the nonvolatile elements (STORE operation) takes place automatically at power-down. On power-up, data is restored to the SRAM from the nonvolatile memory (RECALL operation). The STORE and RECALL operations can also be initiated by the user through I²C commands.

For a complete list of related documentation, click [here](#).

Logic Block Diagram

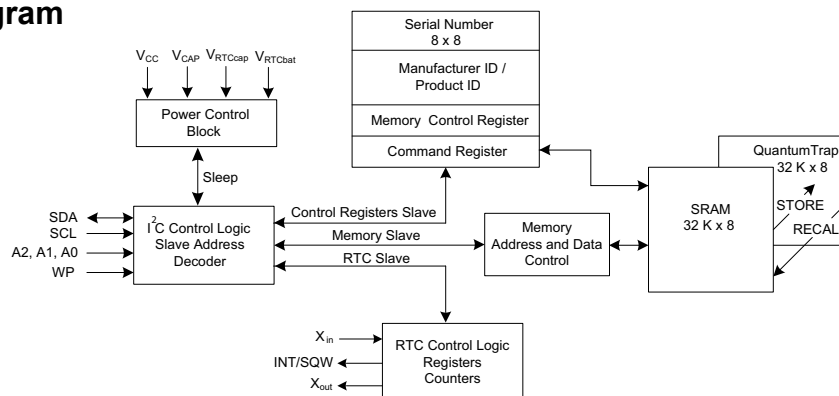

Notes

1. The I²C nvSRAM is a single solution which is usable for all four speed modes of operation. As a result, some I/O parameters are slightly different than those on chips which support only one mode of operation. Refer to AN87209 for more details.
2. Serial (I²C) nvSRAM will be referred to as nvSRAM throughout the datasheet.



Contents

| | | | |
|---|-----------|--|-----------|
| Pinouts | 3 | Watchdog Timer | 21 |
| Pin Definitions | 3 | Programmable Square Wave Generator | 22 |
| I2C Interface | 4 | Power Monitor | 22 |
| Protocol Overview | 4 | Backup Power Monitor | 22 |
| I2C Protocol – Data Transfer | 4 | Interrupts | 22 |
| Data Validity | 5 | Interrupt Register | 22 |
| START Condition (S) | 5 | Flags Register | 23 |
| STOP Condition (P) | 5 | RTC External Components | 24 |
| Repeated START (Sr) | 5 | PCB Design Considerations for RTC | 25 |
| Byte Format | 5 | Layout requirements | 25 |
| Acknowledge / No-acknowledge | 5 | Maximum Ratings | 30 |
| High-Speed Mode (Hs-mode) | 6 | Operating Range | 30 |
| Slave Device Address | 7 | DC Electrical Characteristics | 30 |
| Memory Control Register | 8 | Data Retention and Endurance | 31 |
| Command Register | 8 | Thermal Resistance | 31 |
| Write Protection (WP) | 9 | AC Test Loads and Waveforms | 32 |
| AutoStore Operation | 9 | AC Test Conditions | 32 |
| Hardware STORE and HSB pin Operation | 9 | RTC Characteristics | 32 |
| Hardware RECALL (Power Up) | 9 | AC Switching Characteristics | 33 |
| Write Operation | 10 | Switching Waveforms | 33 |
| Read Operation | 10 | nvSRAM Specifications | 34 |
| Memory Slave Access | 10 | Switching Waveforms | 34 |
| RTC Registers Slave Access | 14 | Software Controlled STORE/RECALL Cycles | 35 |
| Control Registers Slave | 16 | Switching Waveforms | 35 |
| Serial Number | 18 | Hardware STORE Cycle | 36 |
| Serial Number Write | 18 | Switching Waveforms | 36 |
| Serial Number Lock | 18 | Ordering Information | 37 |
| Serial Number Read | 18 | Ordering Code Definitions | 37 |
| Device ID | 19 | Package Diagram | 38 |
| Executing Commands Using Command Register | 19 | Acronyms | 39 |
| Real Time Clock Operation | 20 | Document Conventions | 39 |
| nvTIME Operation | 20 | Units of Measure | 39 |
| Clock Operations | 20 | Document History Page | 40 |
| Reading the Clock | 20 | Sales, Solutions, and Legal Information | 42 |
| Setting the Clock | 20 | Worldwide Sales and Design Support | 42 |
| Backup Power | 20 | Products | 42 |
| Stopping and Starting the Oscillator | 20 | PSoC® Solutions | 42 |
| Calibrating the Clock | 21 | Cypress Developer Community | 42 |
| Alarm | 21 | Technical Support | 42 |

Pinouts

Figure 1. 16-pin SOIC pinout

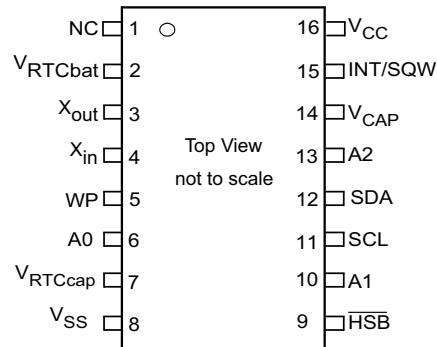

Pin Definitions

| Pin Name | I/O Type | Description |
|------------------------------------|--------------|---|
| SCL | Input | Clock: Runs at speeds up to a maximum of f_{SCL} . |
| SDA | Input/Output | I/O: Input/Output of data through I ² C interface. Output: Is open-drain and requires an external pull-up resistor. |
| WP | Input | Write Protect: Protects the memory from all writes. This pin is internally pulled LOW and hence can be left open if not connected. |
| A2–A0 | Input | Slave Address: Defines the slave address for I ² C. These pins are internally pulled LOW and hence can be left open if not connected. |
| HSB | Input/Output | Hardware STORE Busy: Output: Indicates busy status of nvSRAM when LOW. After each Hardware and Software STORE operation HSB is driven HIGH for a short time (t_{HHHD}) with standard output high current and then a weak internal pull-up resistor keeps this pin HIGH (External pull-up resistor connection optional). Input: Hardware STORE implemented by pulling this pin LOW externally. |
| V _{CAP} | Power supply | AutoStore Capacitor: Supplies power to the nvSRAM during power loss to STORE data from the SRAM to nonvolatile elements. If not required, AutoStore must be disabled and this pin left as No Connect. It must never be connected to ground. |
| V _{RTCcap} ^[3] | Power supply | Capacitor Backup for RTC: Left unconnected if V _{RTCbat} is used. |
| V _{RTCbat} ^[3] | Power supply | Battery Backup for RTC: Left unconnected if V _{RTCcap} is used. |
| X _{out} ^[3] | Output | Crystal output connection |
| X _{in} ^[3] | Input | Crystal input connection |
| INT/SQW ^[3] | Output | Interrupt Output/Calibration/Square Wave. Programmable to respond to the clock alarm, the watchdog timer, and the power monitor. Also programmable to either active HIGH (push or pull) or LOW (open drain). In Calibration mode, a 512 Hz square wave is driven out. In Square Wave mode, the user may select a frequency of 1 Hz, 512 Hz, 4096 Hz, or 32768 Hz to be used as a continuous output. |
| NC | No connect | No connect. This pin is not connected to the die. |
| V _{SS} | Power supply | Ground |
| V _{CC} | Power supply | Power supply |

Note

3. Left unconnected if RTC feature is not used.

I²C Interface

I²C bus consists of two lines – serial clock line (SCL) and serial data line (SDA) – that carry information between multiple devices on the bus. I²C supports multi-master and multi-slave configurations. The data is transmitted from the transmitter to the receiver on the SDA line and is synchronized with the clock SCL generated by the master.

The SCL and SDA lines are open-drain lines and are pulled up to V_{CC} using resistors. The choice of a pull-up resistor on the system depends on the bus capacitance and the intended speed of operation. The master generates the clock, and all the data I/Os are transmitted in synchronization with this clock. The CY14X256I supports up to 3.4 MHz clock speed on SCL line.

Protocol Overview

This device supports only a 7-bit addressable scheme. The master generates a START condition to initiate the communication followed by broadcasting a slave select byte. The slave select byte consists of a 7-bit slave address that the master intends to communicate with and R/W bit indicating a read or a write operation. The selected slave responds to this with an acknowledgement (ACK). After a slave is selected, the remaining part of the communication takes place between the master and the selected slave device. The other devices on the bus ignore the signals on the SDA line until a STOP or Repeated START condition is detected. The data transfer is done between the master and the selected slave device through the SDA pin synchronized with the SCL clock generated by the master.

I²C Protocol – Data Transfer

Each transaction in I²C protocol starts with the master generating a START condition on the bus, followed by a 7-bit slave address and eighth bit (R/W) indicating a read (1) or a write

(0) operation. All signals are transmitted on the open-drain SDA line and are synchronized with the clock on SCL line. Each byte of data transmitted on the I²C bus is acknowledged by the receiver by holding the SDA line LOW on the ninth clock pulse. The request for write by the master is followed by the memory address and data bytes on the SDA line. The writes can be performed in burst-mode by sending multiple bytes of data. The memory address increments automatically after the receive/transmit of each byte on the falling edge of the ninth clock cycle. The new address is latched just prior to sending/receiving the acknowledgment bit. This allows the next sequential byte to be accessed with no additional addressing. On reaching the last memory location, the address rolls back to 0x0000 and writes continue. The slave responds to each byte sent by the master during a write operation with an ACK. A write sequence can be terminated by the master generating a STOP or Repeated START condition.

A read request is performed at the current address location (address next to the last location accessed for read or write). The memory slave device responds to a read request by transmitting the data on the current address location to the master. A random address read may also be performed by first sending a write request with the intended address of read. The master must abort the write immediately after the last address byte and issue a Repeated START or STOP signal to prevent any write operation. The following read operation starts from this address. The master acknowledges the receipt of one byte of data by holding the SDA pin LOW for the ninth clock pulse. The reads can be terminated by the master sending a no-acknowledge (NACK) signal on the SDA line after the last data byte. The NACK signal causes the CY14X256I to release the SDA line and the master can then generate a STOP or a Repeated START condition to initiate a new operation.

Figure 2. System Configuration using Serial (I²C) nvSRAM

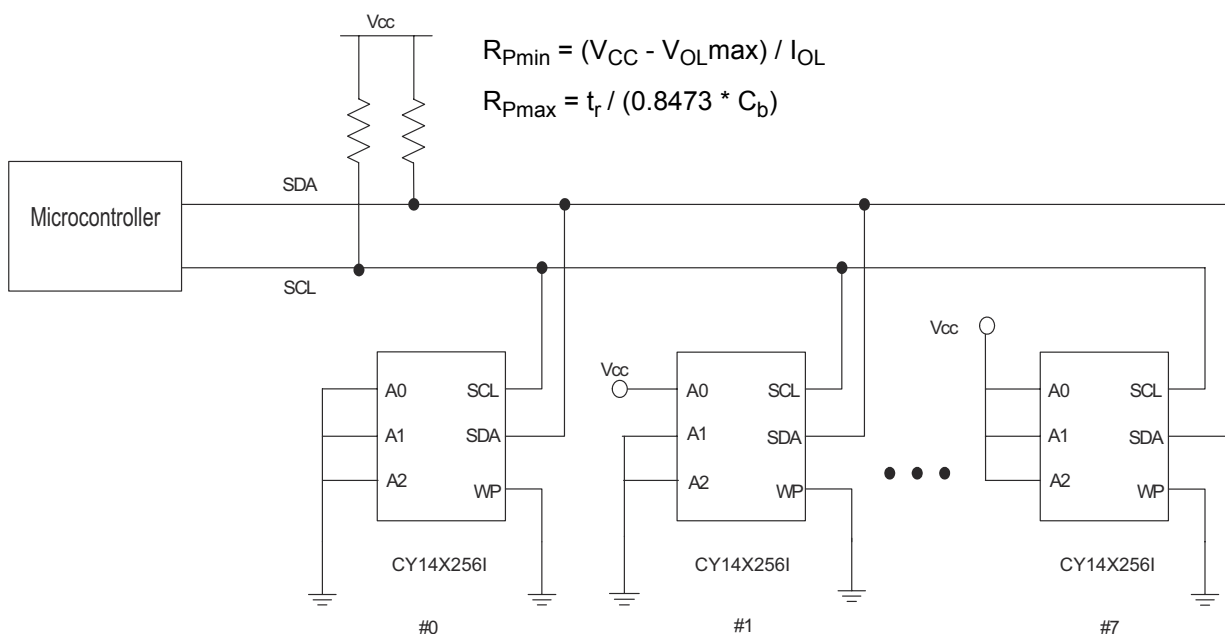

Data Validity

The data on the SDA line must be stable during the HIGH period of the clock. The state of the data line can only change when the clock on the SCL line is LOW for the data to be valid. There are only two conditions under which the SDA line may change state with SCL line held HIGH: START and STOP condition. The START and STOP conditions are generated by the master to signal the beginning and end of a communication sequence on the I²C bus.

START Condition (S)

A HIGH to LOW transition on the SDA line while SCL is HIGH indicates a START condition. Every transaction in I²C begins with the master generating a START condition.

STOP Condition (P)

A LOW to HIGH transition on the SDA line while SCL is HIGH indicates a STOP condition. This condition indicates the end of the ongoing transaction.

START and STOP conditions are always generated by the master. The bus is considered to be busy after the START condition. The bus is considered to be free again after the STOP condition.

Repeated START (Sr)

If a Repeated START condition is generated instead of a STOP condition, the bus continues to be busy. The ongoing transaction on the I²C lines is stopped and the bus waits for the master to send a slave ID for communication to restart.

Figure 3. START and STOP Conditions

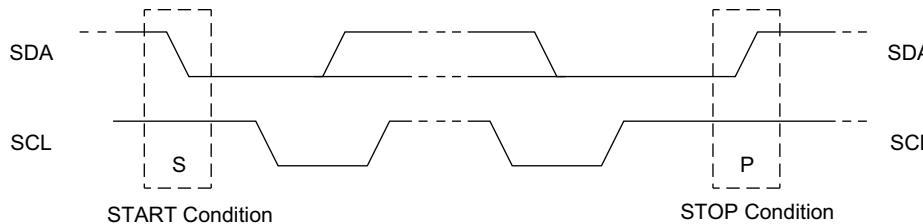
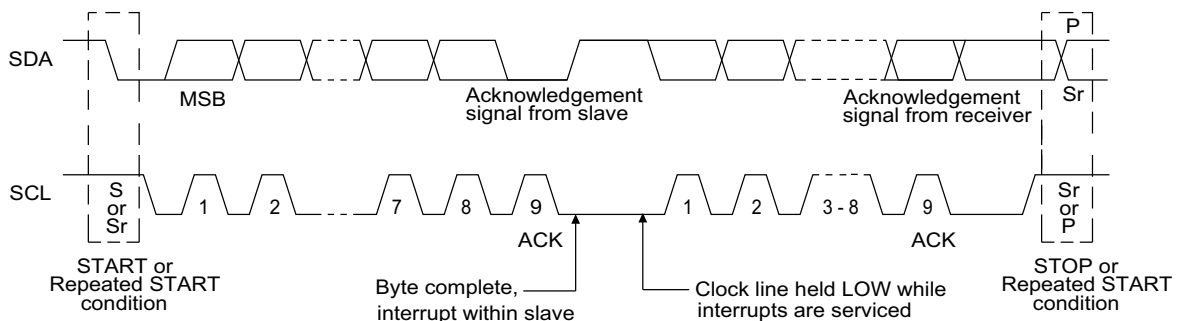

Figure 4. Data Transfer on the I²C Bus



Byte Format

Each operation in I²C is done using 8-bit words. The bits are sent in MSB first format on SDA line and each byte is followed by an ACK signal by the receiver.

An operation continues till a NACK is sent by the receiver or STOP or Repeated START condition is generated by the master. The SDA line must remain stable when the clock (SCL) is HIGH except for a START or STOP condition.

Acknowledge / No-acknowledge

After transmitting one byte of data or address, the transmitter releases the SDA line. The receiver pulls the SDA line LOW to acknowledge the receipt of the byte. Every byte of data transferred on the I²C bus needs a response with an ACK signal by the receiver to continue the operation. Failing to do so is considered as a NACK state. NACK is the state where receiver

does not acknowledge the receipt of data and the operation is aborted.

NACK can be generated by master during a READ operation in following cases:

- The master did not receive valid data due to noise.
- The master generates a NACK to abort the READ sequence. After a NACK is issued by the master, nvSRAM slave releases control of the SDA pin and the master is free to generate a Repeated START or STOP condition.

NACK can be generated by nvSRAM slave during a WRITE operation in these cases:

- nvSRAM did not receive valid data due to noise.
- The master tries to access write protected locations on the nvSRAM. Master must restart the communication by generating a STOP or Repeated START condition.

Figure 5. Acknowledge on the I²C Bus

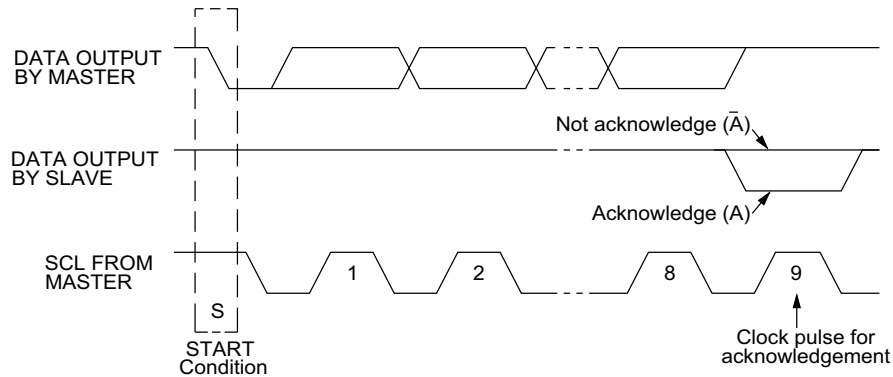

High-Speed Mode (Hs-mode)

In Hs-mode, nvSRAM can transfer data at bit rates of up to 3.4 Mbit/s. A master code (0000 1XXXb) must be issued to place the device in high-speed mode. This enables master/slave communication for speeds up to 3.4 MHz. A stop condition will exit Hs-mode.

Serial Data Format in Hs-mode

Serial data transfer format in Hs-mode meets the standard-mode I²C-bus specification. Hs-mode can only commence after the following conditions (all of which are in F/S-modes):

1. START condition (S)
2. 8-bit master code (0000 1XXXb)
3. No-acknowledge bit (\bar{A})

Single and multiple-byte reads and writes are supported. After the device enters into Hs-mode, data transfer continues in Hs-mode until stop condition is sent by master device. The slave switches back to F/S-mode after a STOP condition (P). To continue data transfer in Hs-mode, the master sends Repeated START (Sr).

See [Figure 13 on page 11](#) and [Figure 16 on page 12](#) for Hs-mode timings for read and write operation.

Figure 6. Data Transfer Format in Hs-mode

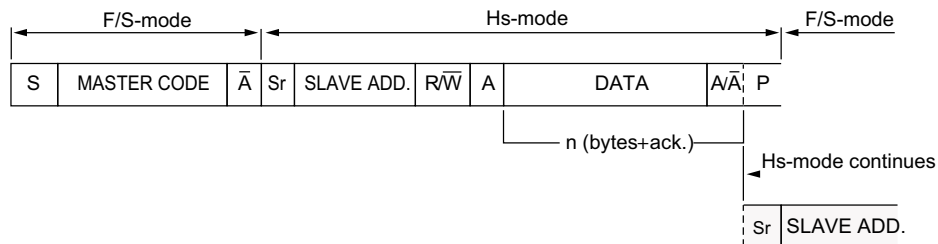

Slave Device Address

Every slave device on an I²C bus has a device select address. The first byte after START condition contains the slave device address with which the master intends to communicate. The seven MSBs are the device address and the LSB (R/W bit) is used for indicating Read or Write operation. The CY14X256I reserves three sets of upper 4 MSBs [7:4] in the slave device address field for accessing the Memory, RTC Registers, and

Control Registers. The accessing mechanism is described in the following section.

The nvSRAM product provides three different functionalities: Memory, RTC Registers and Control Registers functions (such as serial number and product ID). The three functions of the device are accessed through different slave device addresses. The first four most significant bits [7:4] in the device address register are used to select between the nvSRAM functions.

Table 1. Slave Device Addressing

| Bit 7 | Bit 6 | Bit 5 | Bit 4 | Bit 3 | Bit 2 | Bit 1 | Bit 0 | nvSRAM Function Select |
|-------|-------|-------|-------|------------------|-------|-------|-------|---------------------------|
| 1 | 0 | 1 | 0 | Device select ID | | | R/W | Selects Memory |
| 1 | 1 | 0 | 1 | Device select ID | | | R/W | Selects RTC Registers |
| 0 | 0 | 1 | 1 | Device select ID | | | R/W | Selects Control Registers |

CY14X256I Slave Devices

Memory, 32 K × 8

RTC Registers, 16 × 8

Control Registers

- Memory Control Register, 1 × 8
- Serial Number, 8 × 8
- Device ID, 4 × 8
- Command Register, 1 × 8

Memory Slave Device

The nvSRAM device is selected for read/write if the master issues the slave address as 1010b followed by three bits of device select. If the slave address sent by the master matches with the Memory Slave device address then depending on the R/W bit of the slave address, the data will be either read from (R/W = '1') or written to (R/W = '0') the nvSRAM.

The address length for CY14X256I is 15 bits, and thus it requires two address bytes to map the entire memory address location. The dedicated two address bytes represent bit A0 to A14. However, since the address is only 15-bits, it implies that the first MSB bit that is fed in is ignored by the device. Although this bit is 'don't care', Cypress recommends that this bit is treated as 0 to enable seamless transition to higher memory densities.

Figure 7. Memory Slave Device Address

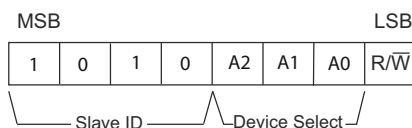

RTC Registers Slave Device

The RTC Registers is selected for read/write if the master issues the slave address as 1101b followed by three bits of device select. Then, depending on the R/W bit of the slave address, data is either read from (R/W = '1') or written to (R/W = '0') the RTC Registers. The RTC Registers slave address is followed by one byte address of RTC Register for read/write operation. The RTC Registers map is explained in the Table 10.

Figure 8. RTC Registers Slave Device Address

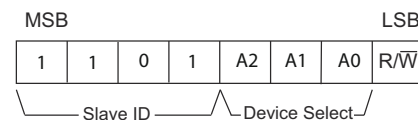

Control Registers Slave Device

The Control Registers Slave device includes the serial number, product ID, Memory Control, and Command Register.

The nvSRAM Control Register Slave device is selected for read/write if the master issues the slave address as 0011b followed by three bits of device select. Then, depending on the R/W bit of the slave address, data is either read from (R/W = '1') or written to (R/W = '0') the device.

Figure 9. Control Registers Slave Device Address

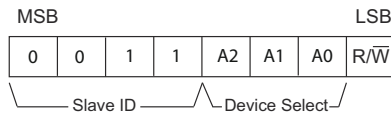

Table 2. Control Registers Map

| Address | Description | Read/Write | Details |
|---------|-------------------------|--|---|
| 0x00 | Memory Control Register | Read/Write | Contains Block Protect bits and Serial Number lock bit |
| 0x01 | Serial Number 8 bytes | Read/Write (Read only when SNL is set) | Programmable Serial Number. Locked by setting the Serial Number lock bit in the Memory Control Register to '1'. |
| 0x02 | | | |
| 0x03 | | | |
| 0x04 | | | |
| 0x05 | | | |
| 0x06 | | | |
| 0x07 | | | |
| 0x08 | | | |
| 0x09 | Device ID | Read only | Device ID is factory programmed |
| 0x0A | | | |
| 0x0B | | | |
| 0x0C | | | |
| 0x0D | Reserved | Reserved | Reserved |
| 0xAA | Command Register | Write only | Allows commands for STORE, RECALL, AutoStore Enable/Disable, SLEEP Mode |

Memory Control Register

The Memory Control Register contains the following bits:

Table 3. Memory Control Register Bits

| Bit 7 | Bit 6 | Bit 5 | Bit 4 | Bit 3 | Bit 2 | Bit 1 | Bit 0 |
|-------|---------|-------|-------|---------|---------|-------|-------|
| 0 | SNL (0) | 0 | 0 | BP1 (0) | BP0 (0) | 0 | 0 |

■ **BP1:BP0:** Block protect bits are used to protect 1/4, 1/2 or full memory array. These bits can be written through a write instruction to the 0x00 location of the Control Register Slave device. However, any STORE cycle transfers SRAM data into a nonvolatile cell regardless of whether or not the block is protected. The default value shipped from the factory for BP0 and BP1 is '0'.

Table 4. Block Protection

| Level | BP1:BP0 | Block Protection |
|-------|---------|------------------|
| 0 | 00 | None |
| 1/4 | 01 | 0x6000–0x7FFF |
| 1/2 | 10 | 0x4000–0x7FFF |
| 1 | 11 | 0x0000–0x7FFF |

■ **S/N Lock (SNL) Bit:** Serial Number Lock bit (SNL) is used to lock the serial number. After the bit is set to '1', the serial number registers are locked and no modification is allowed. This bit cannot be cleared to '0'. The serial number is secured on the next STORE operation (Software STORE or AutoStore). If AutoStore is not enabled, user must perform the Software STORE operation to secure the lock bit status. If a STORE was not performed, the serial number lock bit will not survive the power cycle. The default value shipped from the factory for SNL is '0'.

Command Register

The Command Register resides at address 'AA' of the Control Registers Slave device. This is a write only register. The byte written to this register initiates a STORE, RECALL, AutoStore Enable, AutoStore Disable, and Sleep mode operation as listed in Table 5. The section [Executing Commands Using Command Register on page 19](#) explains how you can execute Command Register bytes.

Table 5. Command Register Bytes

| Data Byte [7:0] | Command | Description |
|-----------------|---------|---|
| 0011 1100 | STORE | STORE SRAM data to nonvolatile memory |
| 0110 0000 | RECALL | RECALL data from nonvolatile memory to SRAM |
| 0101 1001 | ASENB | Enable AutoStore |
| 0001 1001 | ASDISB | Disable AutoStore |
| 1011 1001 | SLEEP | Enter Sleep Mode for low power consumption |

■ **STORE:** Initiates nvSRAM Software STORE. The nvSRAM cannot be accessed for t_{STORE} time after this instruction has been executed. When initiated, the device performs a STORE operation regardless of whether or not a write has been performed since the last NV operation. After the t_{STORE} cycle time is completed, the SRAM is activated again for read/write operations.

■ **RECALL:** Initiates nvSRAM Software RECALL. The nvSRAM cannot be accessed for t_{RECALL} time after this instruction has been executed. The RECALL operation does not alter the data in the nonvolatile elements. A RECALL may be initiated in two ways: Hardware RECALL, initiated on power-up; and Software RECALL, initiated by a I²C RECALL instruction.

■ **ASENB:** Enables nvSRAM AutoStore. The nvSRAM cannot be accessed for t_{SS} time after this instruction has been executed. This setting is not nonvolatile and needs to be followed by a manual STORE sequence if this is desired to survive the power cycle. The part comes from the factory with AutoStore Enabled and 0x00 written in all cells.

■ **ASDISB:** Disables nvSRAM AutoStore. The nvSRAM cannot be accessed for t_{SS} time after this instruction has been executed. This setting is not nonvolatile and needs to be followed by a manual STORE sequence if this is desired to survive power cycle.

Note If AutoStore is disabled and V_{CAP} is not required, it is required that the V_{CAP} pin is left open. V_{CAP} pin must never be



connected to ground. Power Up RECALL operation cannot be disabled in any case.

■ **SLEEP:** SLEEP instruction puts the nvSRAM in a sleep mode. When the SLEEP instruction is registered, the nvSRAM takes t_{SS} time to process the SLEEP request. Once the SLEEP command is successfully registered and processed, the nvSRAM toggles HSB LOW, performs a STORE operation to secure the data to nonvolatile memory and then enters into SLEEP mode. Whenever nvSRAM enters into sleep mode, it initiates non volatile STORE cycle which results in losing an endurance cycle per sleep command execution. A STORE cycle starts only if a write to the SRAM has been performed since the last STORE or RECALL cycle.

The nvSRAM enters into sleep mode in this manner:

1. The master sends a START command.
2. The master sends Control Registers Slave device ID with I²C write bit set (R/W = '0').
3. The slave (nvSRAM) sends an ACK back to the master.
4. The master sends Command Register address (0xAA).
5. The slave (nvSRAM) sends an ACK back to the master.
6. The master sends Command Register byte for entering into sleep mode.
7. The slave (nvSRAM) sends an ACK back to the master.
8. The master generates a STOP condition.

Once in sleep mode, the device starts consuming I_{ZZ} current t_{SLEEP} time after SLEEP instruction is registered. The device is not accessible for normal operations until it is out of sleep mode. The nvSRAM wakes up after t_{WAKE} duration after the device slave address is transmitted by the master.

Transmitting any of the three slave addresses wakes the nvSRAM from sleep mode. The nvSRAM device is not accessible during t_{SLEEP} and t_{WAKE} interval and any attempt to access the nvSRAM device by the master is ignored and nvSRAM sends NACK to the master. An alternate method of determining when the device is ready is for the master to send read or write commands and look for an ACK.

Write Protection (WP)

The Write Protect (WP) pin is an active HIGH pin and protects the entire memory and all registers from write operations. To inhibit all the write operations, this pin must be held HIGH. When this pin is HIGH, all memory and register writes are prohibited and the address counter is not incremented. This pin is internally pulled LOW and, therefore, can be left open if not used.

AutoStore Operation

The AutoStore operation is a unique feature of nvSRAM that automatically stores the SRAM data to QuantumTrap cells during power-down. This STORE makes use of an external capacitor (V_{CAP}) and enables the device to safely STORE the data in the nonvolatile memory when power goes down.

During normal operation, the device draws current from V_{CC} to charge the capacitor connected to the V_{CAP} pin. When the voltage on the V_{CC} pin drops below V_{SWITCH} during power-down, the device inhibits all memory accesses to nvSRAM and automatically performs a conditional STORE operation using the charge from the V_{CAP} capacitor. The AutoStore operation is not

initiated if no write cycle has been performed since the last STORE or RECALL.

Note If a capacitor is not connected to V_{CAP} pin, AutoStore must be disabled by issuing the AutoStore Disable instruction specified in [Command Register on page 8](#). If AutoStore is enabled without a capacitor on V_{CAP} pin, the device attempts an AutoStore operation without sufficient charge to complete the Store. This will corrupt the data stored in nvSRAM as well as the serial number and it will unlock the SNL bit.

[Figure 10](#) shows the proper connection of the storage capacitor (V_{CAP}) for AutoStore operation. See the [DC Electrical Characteristics on page 30](#) for the size of the V_{CAP} .

Figure 10. AutoStore Mode

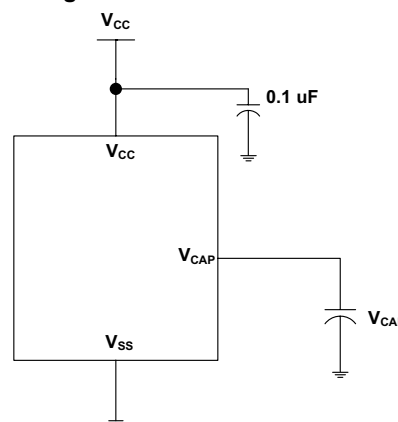

Hardware STORE and HSB pin Operation

The HSB pin in CY14X256I is used to control and acknowledge STORE operations. If no STORE or RECALL is in progress, this pin can be used to request a Hardware STORE cycle. When the HSB pin is driven LOW, the device conditionally initiates a STORE operation after t_{DELAY} duration. An actual STORE cycle starts only if a write to the SRAM has been performed since the last STORE or RECALL cycle. Reads and Writes to the memory are inhibited for t_{STORE} duration or as long as HSB pin is LOW.

The HSB pin also acts as an open drain driver (internal 100 k Ω weak pull-up resistor) that is internally driven LOW to indicate a busy condition when the STORE (initiated by any means) is in progress.

Note After each Hardware and Software STORE operation HSB is driven HIGH for a short time (t_{HHHD}) with standard output high current and then remains HIGH by internal 100 k Ω pull-up resistor.

Note For successful last data byte STORE, a hardware STORE should be initiated at least one clock cycle after the last data bit D0 is received.

Upon completion of the STORE operation, the nvSRAM memory access is inhibited for t_{LZHSB} time after HSB pin returns HIGH. Leave the HSB pin unconnected if not used.

Hardware RECALL (Power Up)

During power-up, when V_{CC} crosses V_{SWITCH} , an automatic RECALL sequence is initiated that transfers the content of nonvolatile memory to the SRAM. The data may have been

previously stored on the nonvolatile memory through a STORE sequence.

A Power Up RECALL cycle takes t_{FA} time to complete and the memory access is disabled during this time. HSB pin can be used to detect the ready status of the device.

Write Operation

The last bit of the slave device address indicates a read or a write operation. In case of a write operation, the slave device address is followed by the memory or register address and data. A write operation continues as long as a STOP or Repeated START condition is generated by the master or if a NACK is issued by the nvSRAM.

A NACK is issued from the nvSRAM under the following conditions:

1. A valid Device ID is not received.
2. A write (burst write) access to a protected memory block address returns a NACK from nvSRAM after the data byte is received. However, the address counter is set to this address and the following current read operation starts from this address.
3. A write/random read access to an invalid or out-of-bound memory address returns a NACK from the nvSRAM after the address is received. The address counter remains unchanged in such a case.

After a NACK is sent out from the nvSRAM, the write operation is terminated and any data on the SDA line is ignored till a STOP or a Repeated START condition is generated by the master.

For example, consider a case where the burst write access is performed on Control Register Slave address 0x01 for writing the serial number and continued to the address 0x09, which is a read-only register. The device returns a NACK and address counter is not incremented. A following read operation is started from the address 0x09. Further, any write operation which starts from a write protected address (say, 0x09) is responded by the nvSRAM with a NACK after the data byte is sent and set the address counter to this address. A following read operation starts from the address 0x09 in this case also.

Note In case you try to read/write access an address that does not exist (for example 0x0D in Control Register Slave or 0x3F in RTC registers), nvSRAM responds with a NACK immediately after the out-of-bound address is transmitted. The address counter remains unchanged and holds the previous successful read or write operation address.

A write operation is performed internally with no delay after the eighth bit of data is transmitted. If a write operation is not intended, the master must terminate the write operation before the eighth clock cycle by generating a STOP or Repeated START condition.

More details on write instructions are provided in the section [Memory Slave Access](#).

Read Operation

If the last bit of the slave device address is '1', a read operation is assumed and the nvSRAM takes control of the SDA line immediately after the slave device address byte is sent out by the master. The read operation starts from the current address location (the location following the previous successful write or read operation). When the last address is reached, the address counter loops back to the first address.

In case of the Control Register Slave, whenever a burst read is performed such that it flows to a non-existent address, the reads operation loops back to 0x00. This is applicable, in particular, for the Command Register.

Read operation can be ended using the following methods:

1. The master issues a NACK on the ninth clock cycle followed by a STOP or a Repeated START condition on the tenth clock cycle.
2. The master generates a STOP or Repeated START condition on the ninth clock cycle.

More details on write instruction are provided in the section [Memory Slave Access](#).

Memory Slave Access

The following sections describe the data transfer sequence required to perform read or write operations from nvSRAM.

Write nvSRAM

Each write operation consists of a slave address being transmitted after the start condition. The last bit of slave address must be set as '0' to indicate a Write operation. The master may write one byte of data or continue writing multiple consecutive address locations while the internal address counter keeps incrementing automatically. The address register is reset to 0x0000 after the last address in memory is accessed. The write operation continues till a STOP or Repeated START condition is generated by the master or a NACK is issued by the nvSRAM.

A write operation is executed only after nvSRAM receives all the eight data bits. The nvSRAM sends an ACK signal after a successful write operation. A write operation may be terminated by the master by generating a STOP condition or a Repeated START operation. If the master desires to abort the current write operation without altering the memory contents, this should be done using a START/STOP condition prior to the eighth data bit.

If the master tries to access a write protected memory address on the nvSRAM, a NACK is returned after the data byte intended to write the protected address is transmitted and address counter will not be incremented. Similarly, in a burst mode write operation, a NACK is returned when the data byte that attempts to write a protected memory location and the address counter is not incremented.

Figure 11. Single-Byte Write into nvSRAM (except Hs-mode)

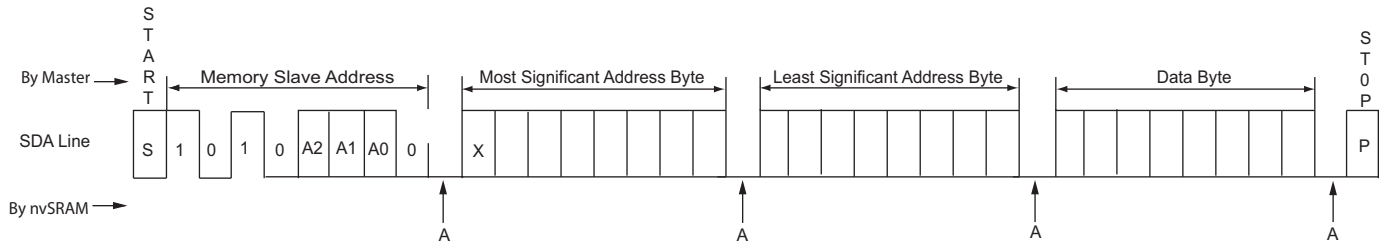

Figure 12. Multi-Byte Write into nvSRAM (except Hs-mode)

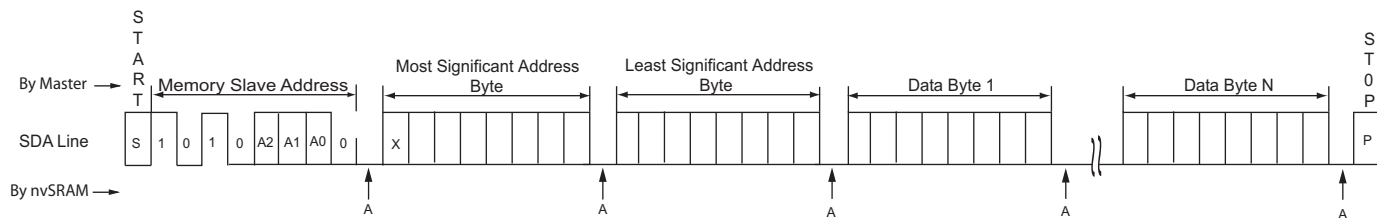

Figure 13. Single-Byte Write into nvSRAM (Hs-mode)

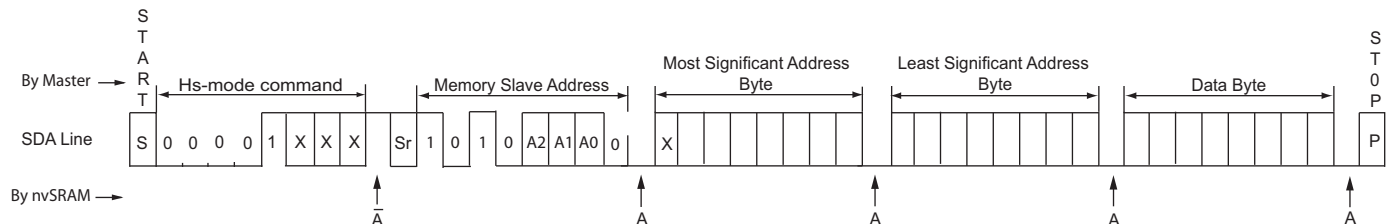
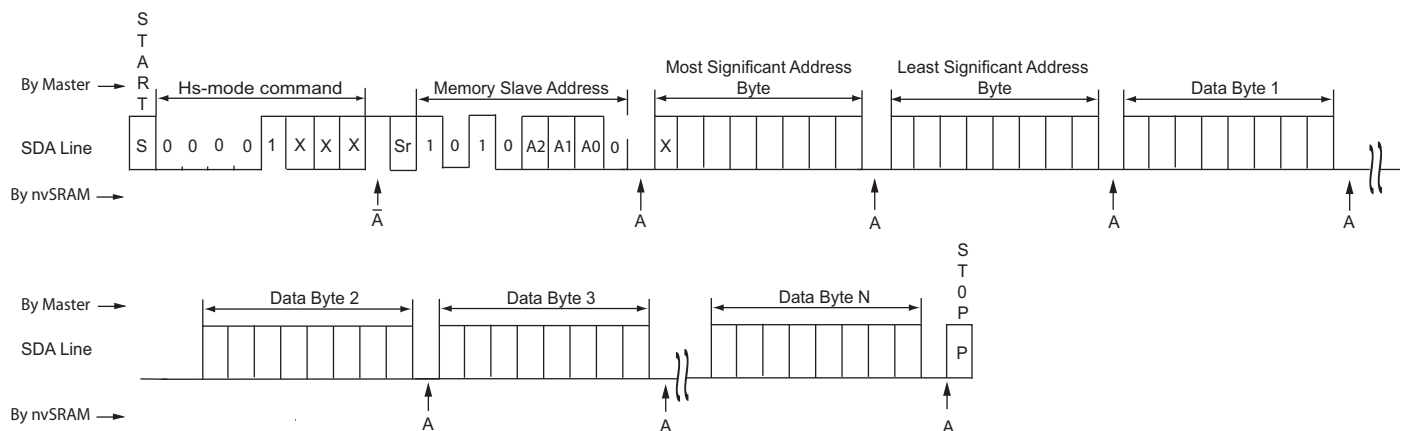

Figure 14. Multi-Byte Write into nvSRAM (Hs-mode)



Current nvSRAM Read

Each read operation starts with the master transmitting the nvSRAM slave address with the LSB set to '1' to indicate 'Read'. The reads start from the address on the address counter. The address counter is set to the address location next to the last accessed with a 'Write' or 'Read' operation. The master may

terminate a read operation after reading 1 byte or continue reading addresses sequentially till the last address in the memory after which the address counter rolls back to the address 0x0000. The valid methods of terminating read access are described in the section [Read Operation on page 10](#).

Figure 15. Current Location Single-Byte nvSRAM Read (except Hs-mode)

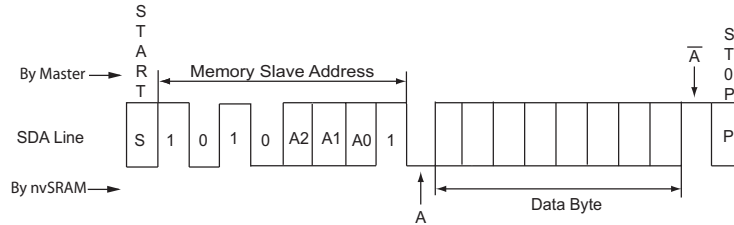

Figure 16. Current Location Multi-Byte nvSRAM Read (except Hs-mode)

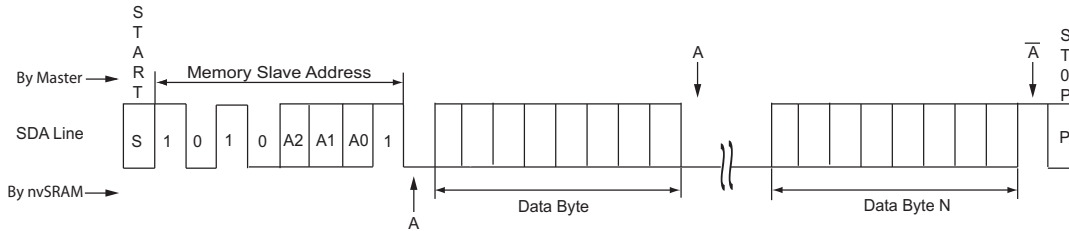

Figure 17. Current Location Single-Byte nvSRAM Read (Hs-mode)

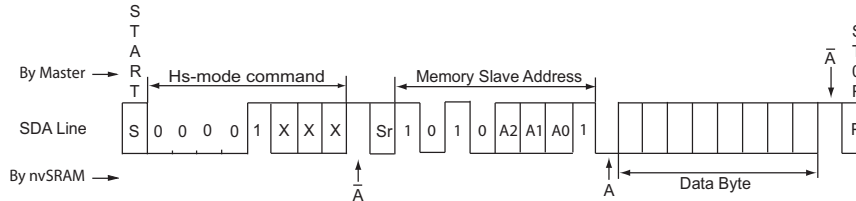
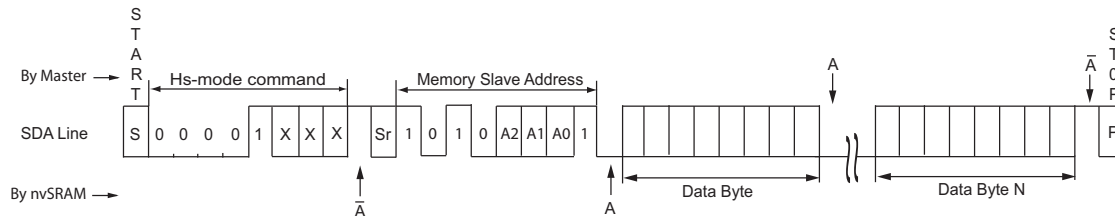

Figure 18. Current Location Multi-Byte nvSRAM Read (Hs-mode)



Random Address Read

A random address read is performed by first initiating a write operation and generating a Repeated START immediately after the last address byte is acknowledged. The address counter is set to this address and the next read access to this slave initiates

read operation from here. The master may terminate a read operation after reading 1 byte or continue reading addresses sequentially till the last address in the memory after which the address counter rolls back to the start address 0x0000.

Figure 19. Random Address Single-Byte Read (except Hs-mode)

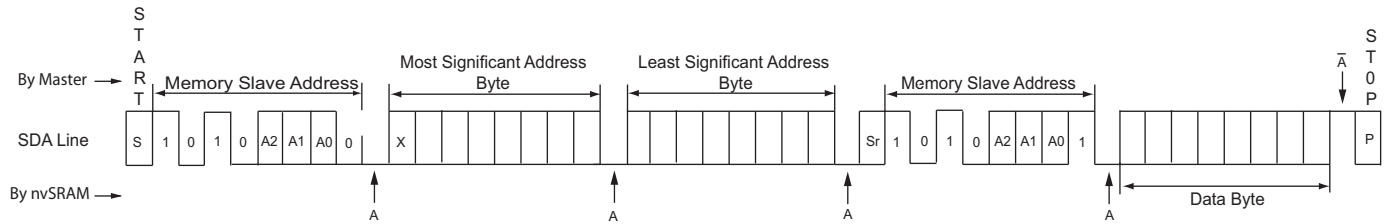

Figure 20. Random Address Multi-Byte Read (except Hs-mode)

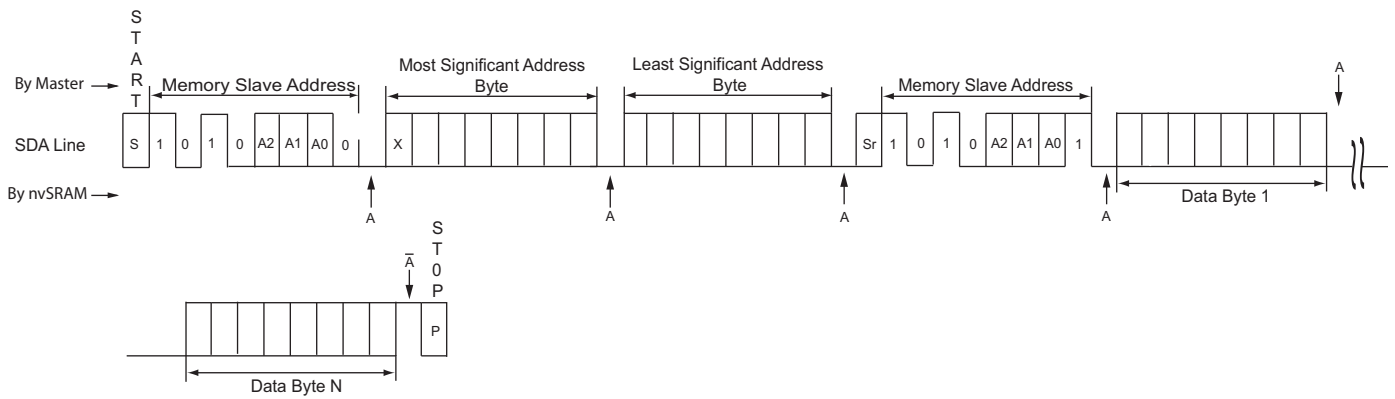

Figure 21. Random Address Single-Byte Read (Hs-mode)

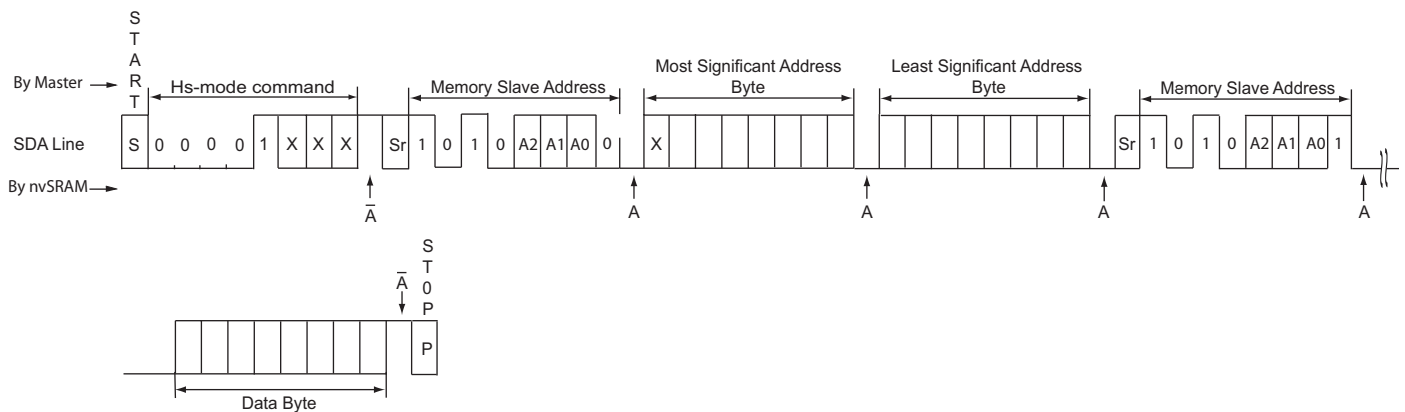
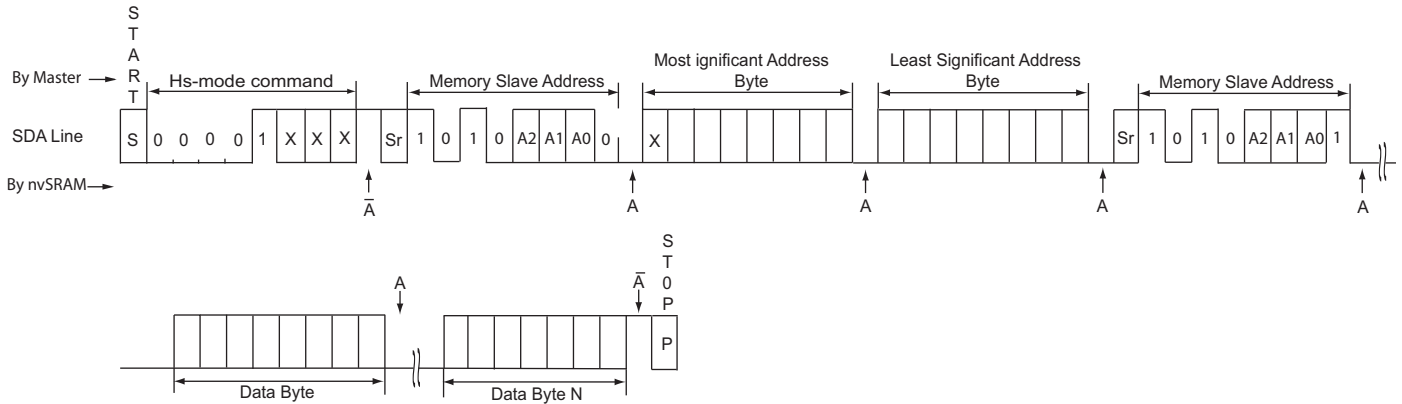

Figure 22. Random Address Multi-Byte Read (Hs-mode)



RTC Registers Slave Access

The following sections describe the data transfer sequence required to perform read or write operations from RTC registers.

Write RTC Registers

A write to RTC registers is initiated with the RTC Registers Slave address followed by one byte of address and data. The master may write one byte of data or continue writing multiple consecutive address locations while the internal address counter keeps incrementing automatically. The address register is reset to 0x00 after the last RTC register is accessed. The write operation continues till a STOP or Repeated START condition is

generated by the master or a NACK is issued by the nvSRAM RTC Registers Slave.

A write operation is executed only after all the eight data bits have been received by the nvSRAM. The nvSRAM sends an ACK signal after the successful operation of the write instruction. A write operation may be terminated by the master by generating a STOP condition or a Repeated START operation before the last data bit is sent.

If the master tries to access an out of bound memory address on the RTC Registers Slave, a NACK is returned after the address byte is transmitted. The address counter remains unaffected and the following current read operation starts from the address value held in the address counter.

Figure 23. Single-Byte Write into RTC Registers

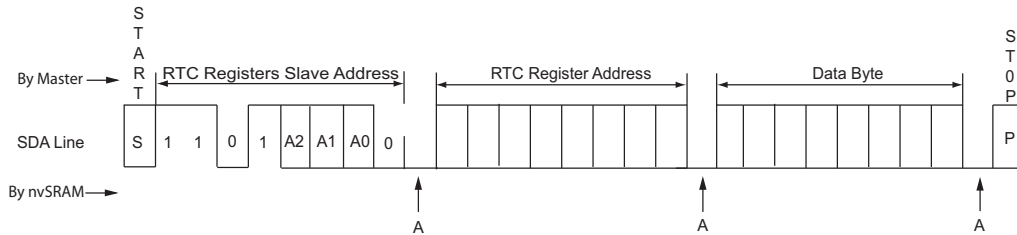
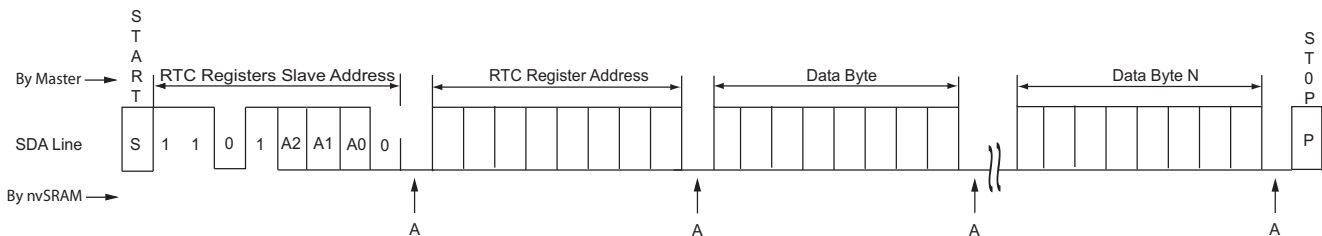

Figure 24. Multi-Byte Write into RTC Registers



Current Address RTC Registers Read

A current read of RTC registers starts with the master sending the RTC Registers Slave address after the START condition. All read operations begin from the current address (the address next to previously accessed address location). After the last address is read sequentially, the address latch loops back to the first location (0x00) and read operation continues. The master

may terminate a read operation after reading one byte or continue reading addresses sequentially till the last address in the memory after which the address counter rolls back to the address 0x00. A read operation may be terminated by the master by generating a STOP condition or a Repeated START operation or a NACK.

Figure 25. Current Address RTC Registers Single-Byte Read

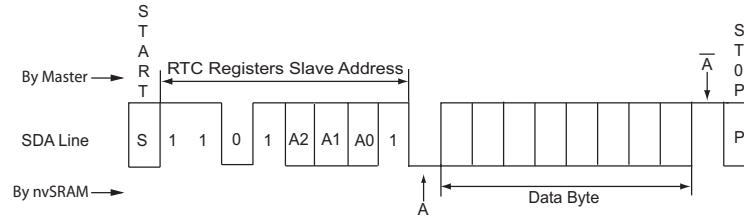
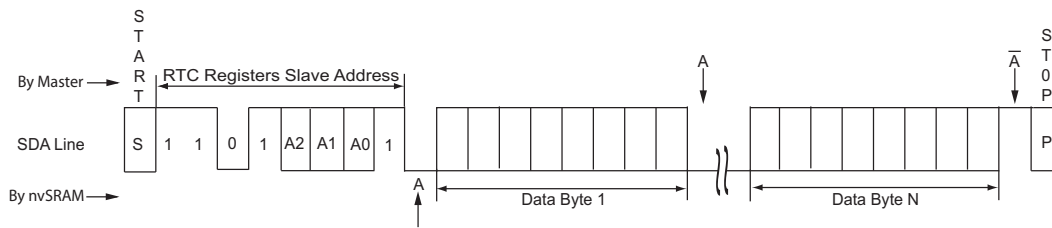

Figure 26. Current Address RTC Registers Multi-Byte Read



Random Address RTC Registers Read

A random address read is performed by first initiating a write operation and generating a Repeated START immediately after the last address byte is acknowledged. The address counter is set to this address and the next read access to this slave initiates the read operation from here. The master may terminate a read operation after reading one byte or continue reading addresses sequentially till the last address in the memory after which the

address counter rolls back to the start address location of RTC (0x00).

A random address read attempt on an out of bound memory address is responded back with a NACK from the nvSRAM after the address byte is transmitted. The address counter remains unaffected and the following current read operation starts from the address value held in the address counter.

Figure 27. Random Address RTC Registers Single-Byte Read

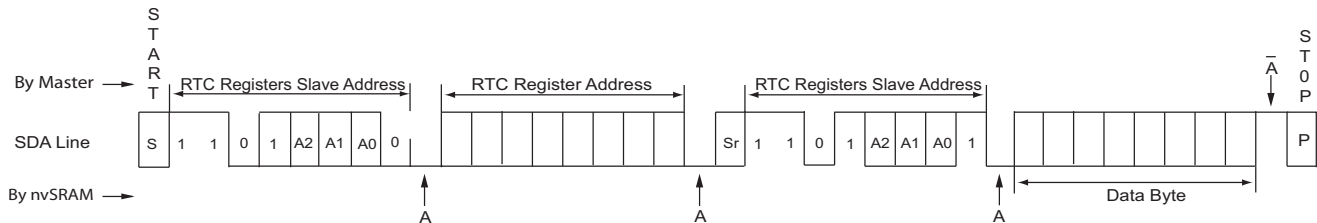
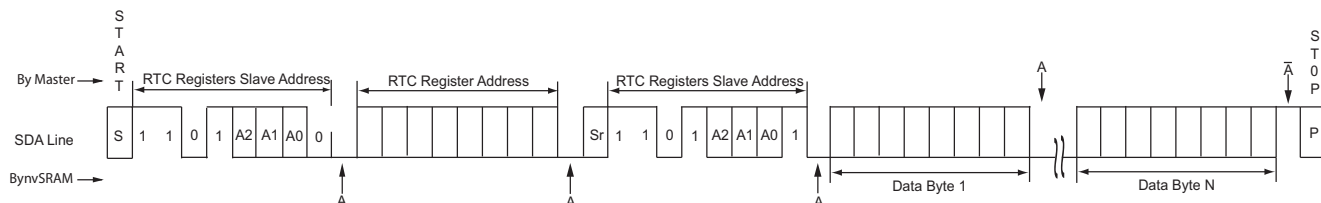

Figure 28. Random Address RTC Registers Multi-Byte Read



Control Registers Slave

The following sections describe the data transfer sequence required to perform read or write operations from Control Registers Slave.

Write Control Registers

To write the Control Registers Slave, the master transmits the Control Registers Slave address after generating the START condition. The write sequence continues from the address location specified by the master till the master generates a STOP condition or the last writable address location.

If a non-writable address location is accessed for write operation during a normal write or a burst, the slave generates a NACK after the data byte is sent and the write sequence terminates. Any following data bytes are ignored and the address counter is not incremented.

If a write operation is performed on the Command Register (0xAA), the following current read operation also begins from the

first address (0x00) as in this case, the current address is an out-of-bound address. The address is not incremented and the next current read operation begins from this address location. If a write operation is attempted on an out-of-bound address location, the nvSRAM sends a NACK immediately after the address byte is sent.

Further, if the serial number is locked, only two addresses (0xAA or Command Register, and 0x00 or Memory Control Register) are writable in the Control Registers Slave. On a write operation to any other address location, the device will acknowledge command byte and address bytes but it returns a NACK from the control Registers Slave for data bytes. In this case, the address will not be incremented and a current read will happen from the last acknowledged address.

The nvSRAM Control Registers Slave sends a NACK when an out of bound memory address is accessed for write operation, by the master. In such a case, a following current read operation begins from the last acknowledged address.

Figure 29. Single-Byte Write into Control Registers

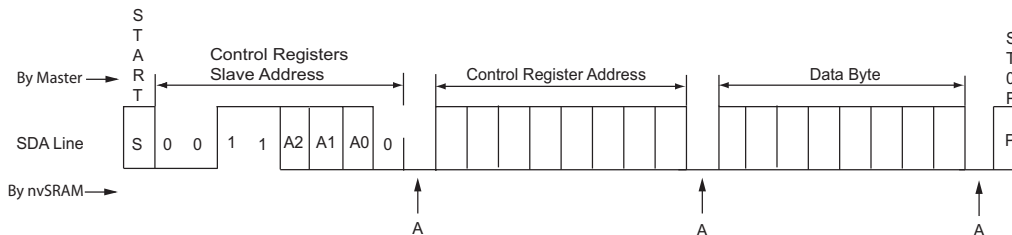
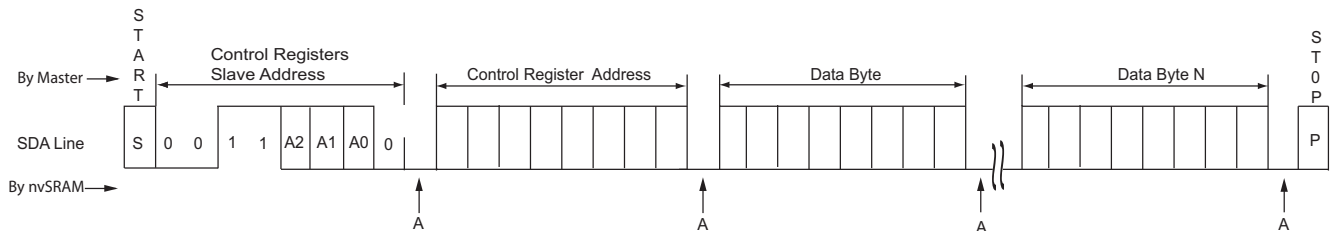

Figure 30. Multi-Byte Write into Control Registers



Current Control Registers Read

A read of Control Registers Slave is started with master sending the Control Registers Slave address after the START condition with the LSB set to '1'. The reads begin from the current address which is the next address to the last accessed location. The reads to Control Registers Slave continues until the last readable

address location and loops back to the first location (0x00). Note that the Command Register is a write only register and is not accessible through the sequential read operations. If a burst read operation begins from the Command Register (0xAA), the address counter wraps around to the first address in the register map (0x00).

Figure 31. Control Registers Single-Byte Read

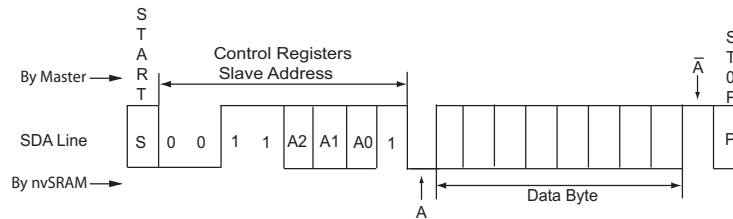
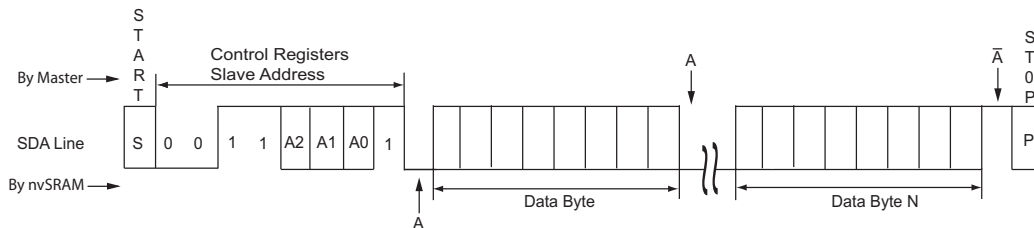

Figure 32. Current Control Registers Multi-Byte Read



Random Control Registers Read

A read of random address may be performed by initiating a write operation to the intended location of read and immediately following with a Repeated START operation. The reads to Control Registers Slave continues till the last readable address location and loops back to the first location (0x00). Note that the

Command Register is a write only register and is not accessible through the sequential read operations. A random read starting at the Command Register (0xAA) loops back to the first address in the Control Register register map (0x00). If a random read operation is initiated from an out-of-bound memory address, the nvSRAM sends a NACK after the address byte is sent.

Figure 33. Random Control Registers Single-Byte Read

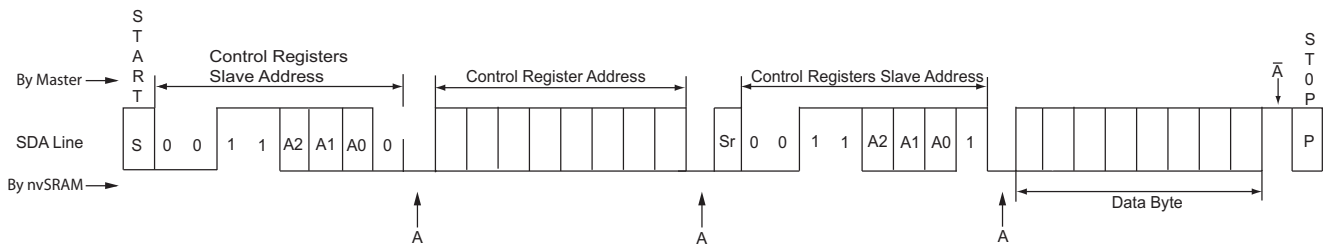
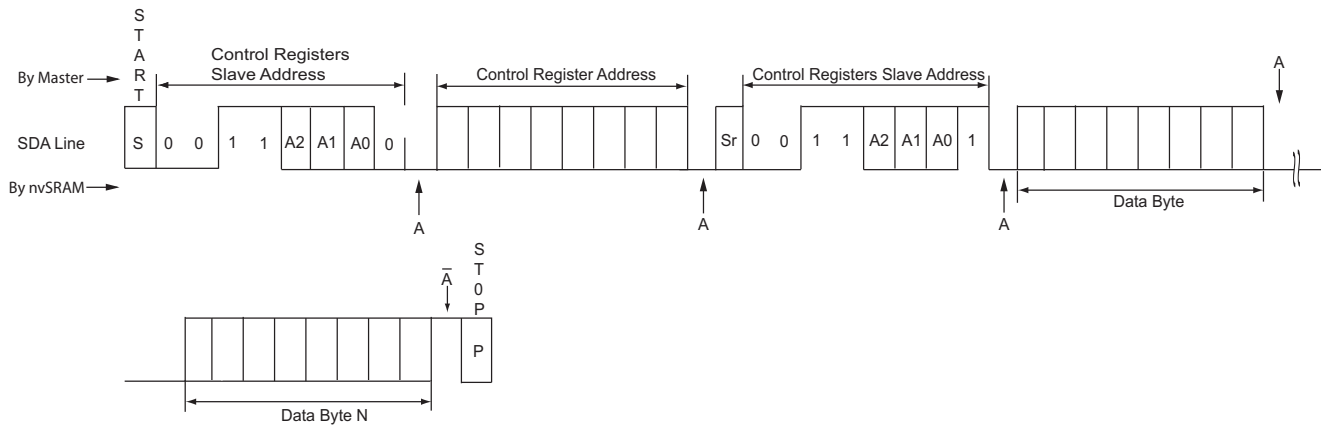

Figure 34. Random Control Registers Multi-Byte Read

Serial Number

Serial number is an 8 byte memory space provided to the user to uniquely identify this device. It typically consists of a two byte customer ID, followed by five bytes of unique serial number and one byte of CRC check. However, nvSRAM does not calculate the CRC and it is up to the user to utilize the eight byte memory space in the desired format. The default values for the eight byte locations are set to '0x00'.

Serial Number Write

The serial number can be accessed through the Control Registers Slave Device. To write the serial number, master transmits the Control Registers Slave address after the START condition and writes to the address location from 0x01 to 0x08. The content of Serial Number registers is secured to nonvolatile memory on the next STORE operation. If AutoStore is enabled, nvSRAM automatically stores the serial number in the nonvolatile memory on power-down. However, if AutoStore is disabled, user must perform a STORE operation to secure the contents of Serial Number registers.

Note If the serial number lock (SNL) bit is not set, the serial number registers can be re-written regardless of whether or not a STORE has happened. After the serial number lock bit is set, no writes to the serial number registers are allowed. If the master tries to perform a write operation to the serial number registers

when the lock bit is set, a NACK is returned and write is not performed.

Serial Number Lock

After writes to serial number registers is complete, the master is responsible for locking the serial number by setting the serial number lock bit to '1' in the Memory Control Register (0x00). The content of Memory Control Register and serial number are secured on the next STORE operation (STORE or AutoStore). If AutoStore is not enabled, user must perform the STORE operation to secure the lock bit status.

If a STORE was not performed, the serial number lock bit will not survive the power cycle. The serial number lock bit and 8-byte serial number is defaults to '0' at power-up.

Serial Number Read

Serial number can be read back by a read operation of the intended address of the Control Registers Slave. The Control Registers Device loops back from the last address (excluding the Command Register) to 0x00 address location while performing burst read operation. The serial number resides in the locations from 0x01 to 0x08. Even if the serial number is not locked, a serial number read operation returns the current values written to the serial number registers. The master may perform a serial number read operation to confirm if the correct serial number is written to the registers before setting the lock bit.

Device ID

Device ID is a 4-byte code consisting of JEDEC assigned manufacturer ID, product ID, density ID, and die revision. These registers are set in the factory and are read only registers for the user.

Table 6. Device ID

| Device | Device ID (4 bytes) | Device ID Description | | | |
|-----------|---------------------|-----------------------|----------------|--------------|--------------|
| | | 31–21 (11 bits) | 20–7 (14 bits) | 6–3 (4 bits) | 2–0 (3 bits) |
| | | Manufacturer ID | Product ID | Density ID | Die Rev |
| CY14C256I | 0x0681E290 | 00000110100 | 00001111000101 | 0010 | 000 |
| CY14B256I | 0x0681EA90 | 00000110100 | 00001111010101 | 0010 | 000 |
| CY14E256I | 0x0681F290 | 00000110100 | 00001111100101 | 0010 | 000 |

The device ID is divided into four parts as shown in [Table 6](#):

1. Manufacturer ID (11 bits)

This is the JEDEC assigned manufacturer ID for Cypress. JEDEC assigns the manufacturer ID in different banks. The first three bits of the manufacturer ID represent the bank in which ID is assigned. The next eight bits represent the manufacturer ID.

Cypress manufacturer ID is 0x34 in bank 0. Therefore the manufacturer ID for all Cypress nvSRAM products is as given below:

Cypress ID - 000_0011_0100

2. Product ID (14 bits)

The product ID for device is shown in the [Table 6](#).

3. Density ID (4 bits)

The 4-bit density ID is used as shown in [Table 6](#) for indicating the 256 Kb density of the product.

4. Die Rev (3 bits)

This is used to represent any major change in the design of the product. The initial setting of this is always 0x0.

Executing Commands Using Command Register

The Control Registers Slave allows different commands to be executed by writing the specific command byte in the Command Register (0xAA). The command byte codes for each command are specified in [Table 5 on page 8](#). During the execution of these commands the device is not accessible and returns a NACK if any of the three slave devices is selected. If an invalid command is sent by the master, the nvSRAM responds with an ACK indicating that the command has been acknowledged with NOP (No Operation). The address will rollover to 0x00 location.

Figure 35. Command Execution using Command Register

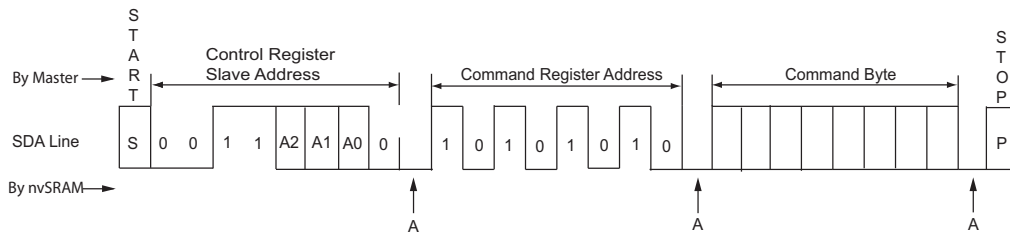



Real Time Clock Operation

nvTIME Operation

The CY14X256I offers internal registers that contain clock, alarm, watchdog, interrupt, and control functions. The RTC registers occupy a separate address space from nvSRAM and are accessible through the Read RTC register and Write RTC register sequence on register addresses 0x00 to 0x0F. Internal double buffering of the clock and the timer information registers prevents accessing transitional internal clock data during a read or write operation. Double buffering also circumvents disrupting normal timing counts or the clock accuracy of the internal clock when accessing clock data. Clock and alarm registers store data in BCD format.

Clock Operations

The clock registers maintain time up to 9,999 years in one-second increments. The time can be set to any calendar time and the clock automatically keeps track of days of the week and month, leap years, and century transitions. There are eight registers dedicated to the clock functions, which are used to set time with a write cycle and to read time with a read cycle. These registers contain the time of day in BCD format. Bits defined as '0' are currently not used and are reserved for future use by Cypress.

Reading the Clock

The double buffered RTC register structure reduces the chance of reading incorrect data from the clock. Internal updates to the CY14X256I time keeping registers are stopped when the read bit 'R' (in the flags register at 0x00) is set to '1' before reading clock data to prevent reading of data in transition. Stopping the register updates does not affect clock accuracy.

When a read sequence of RTC device is initiated, the update of the user timekeeping registers stops and does not restart until a STOP or a Repeated START condition is generated. The RTC registers are read while the internal clock continues to run. After the end of read sequence, all the RTC registers are simultaneously updated within 20 ms.

Setting the Clock

A write access to the RTC device stops updates to the time keeping registers and enables the time to be set when the write bit 'W' (in the flags register at 0x00) is set to '1'. The correct day, date, and time is then written into the registers and must be in 24 hour BCD format. The time written is referred to as the "Base Time". This value is stored in nonvolatile registers and used in the calculation of the current time. When the write bit 'W' is cleared by writing '0' to it and a STOP or Repeated START condition is encountered, the values of timekeeping registers are transferred to the actual clock counters after which the clock resumes normal operation. If a valid STOP or Repeated START condition is not generated by the master, the time written to the RTC registers is never transferred to the actual clock counters.

If the time written to the timekeeping registers is not in the correct BCD format, each invalid nibble of the RTC registers continue counting to 0xF before rolling over to 0x0 after which RTC resumes normal operation.

Note After 'W' bit is set to '0', values written into the timekeeping, alarm, calibration, and interrupt registers are transferred to the

RTC time keeping counters in t_{RTCP} time. These counter values must be saved to nonvolatile memory either by initiating a Software/Hardware STORE or AutoStore operation. While working in AutoStore disabled mode, perform a STORE operation after t_{RTCP} time while writing into the RTC registers for the modifications to be correctly recorded.

Backup Power

The RTC in the CY14X256I is intended for permanently powered operation. The V_{RTCcap} or V_{RTCbat} pin is connected depending on whether a capacitor or battery is chosen for the application. When the primary power, V_{CC} , fails and drops below V_{SWITCH} the device switches to the backup power supply.

The clock oscillator uses very little current, which maximizes the backup time available from the backup source. Regardless of the clock operation with the primary source removed, the data stored in the nvSRAM is secure, having been stored in the nonvolatile elements when power was lost.

During backup operation, the CY14X256I consumes a 0.45 μA (Typ) at room temperature. The user must choose capacitor or battery values according to the application.

Note: If a battery is applied to V_{RTCbat} pin prior to V_{CC} , the chip will draw high I_{BAK} current. This occurs even if the oscillator is disabled. In order to maximize battery life, V_{CC} must be applied before a battery is applied to V_{RTCbat} pin.

Backup time values based on maximum current specifications are shown in the following table. Nominal backup times are approximately two times longer.

Table 7. RTC Backup Time

| Capacitor Value | Backup Time (CY14B256I) |
|-----------------|-------------------------|
| 0.1 F | 60 hours |
| 0.47 F | 12 days |
| 1.0 F | 25 days |

Using a capacitor has the obvious advantage of recharging the backup source each time the system is powered up. If a battery backup is used, a 3-V lithium battery is recommended and the CY14X256I sources current only from the battery when the primary power is removed. However, the battery is not recharged at any time by the CY14X256I. The battery capacity must be chosen for total anticipated cumulative down time required over the life of the system.

Stopping and Starting the Oscillator

The OSCEN bit in the calibration register at 0x08 controls the enable and disable of the oscillator. This bit is nonvolatile and is shipped to customers in the "enabled" (set to '0') state. To preserve the battery life when the system is in storage, OSCEN must be set to '1'. This turns off the oscillator circuit, extending the battery life. If the OSCEN bit goes from disabled to enabled, it takes approximately one second (two seconds maximum) for the oscillator to start.

While system power is off, if the voltage on the backup supply (V_{RTCcap} or V_{RTCbat}) falls below their respective minimum level, the oscillator may fail. The CY14X256I has the ability to detect oscillator failure when system power is restored. This is recorded



in the Oscillator Fail Flag (OSCF) of the flags register at the address 0x00. When the device is powered on (V_{CC} goes above V_{SWITCH}) the OSCEN bit is checked for the 'enabled' status. If the OSCEN bit is enabled and the oscillator is not active within the first 5 ms, the OSCF bit is set to '1'. The system must check for this condition and then write '0' to clear the flag.

Note that in addition to setting the OSCF flag bit, the time registers are reset to the 'Base Time', which is the value last written to the timekeeping registers. The control or calibration registers and the OSCEN bit are not affected by the 'oscillator failed' condition.

The value of OSCF must be reset to '0' when the time registers are written for the first time. This initializes the state of this bit which may have become set when the system was first powered on.

To reset OSCF, set the write bit 'W' (in the flags register at 0x00) to a '1' to enable writes to the flags register. Write a '0' to the OSCF bit and then reset the write bit to '0' to disable writes.

Calibrating the Clock

The RTC is driven by a quartz-controlled crystal with a nominal frequency of 32.768 kHz. Clock accuracy depends on the quality of the crystal and calibration. The crystals available in the market typically have an error of ± 20 ppm to ± 35 ppm. However, CY14X256I employs a calibration circuit that improves the accuracy to ± 1 – ± 2 ppm at 25 °C. This implies an error of ± 2.5 seconds to ± 5 seconds per month.

The calibration circuit adds or subtracts counts from the oscillator divider circuit to achieve this accuracy. The number of pulses that are suppressed (subtracted, negative calibration) or split (added, positive calibration) depends upon the value loaded into the five calibration bits found in the calibration register at 0x08. The calibration bits occupy the five lower order bits in the calibration register. These bits are set to represent any value between '0' and 31 in binary form. Bit D5 is a sign bit, where a '1' indicates positive calibration and a '0' indicates negative calibration. Adding counts speeds the clock up and subtracting counts slows the clock down. If a binary '1' is loaded into the register, it corresponds to an adjustment of 4.068 or -2.034 ppm offset in oscillator error, depending on the sign.

Calibration occurs within a 64-minute cycle. The first 62 minutes in the cycle may, once per minute, have one second shortened by 128 or lengthened by 256 oscillator cycles. If a binary '1' is loaded into the register, only the first two minutes of the 64-minute cycle are modified. If a binary 6 is loaded, the first 12 are affected, and so on. Therefore, each calibration step has the effect of adding 512 or subtracting 256 oscillator cycles for every 125,829,120 actual oscillator cycles, that is, 4.068 or -2.034 ppm of adjustment per calibration step in the calibration register.

To determine the required calibration, the CAL bit in the flags register (0x00) must be set to '1'. This causes the INT pin to toggle at a nominal frequency of 512 Hz. Any deviation measured from the 512 Hz indicates the degree and direction of the required correction. For example, a reading of 512.01024 Hz indicates a ± 20 ppm error. Hence, a decimal value of -10 (001010b) must be loaded into the Calibration register to offset this error.

Note Setting or changing the calibration register does not affect the test output frequency.

To set or clear CAL, set the write bit 'W' (in the flags register at 0x00) to '1' to enable writes to the flags register. Write a value to CAL, and then reset the write bit to '0' to disable writes.

Alarm

The alarm function compares user programmed values of alarm time and date (stored in the registers 0x01-5) with the corresponding time of day and date values. When a match occurs, the alarm internal flag (AF) is set and an interrupt is generated on INT pin if alarm interrupt enable (AIE) bit is set.

There are four alarm match fields - date, hours, minutes, and seconds. Each of these fields has a match bit that is used to determine if the field is used in the alarm match logic. Setting the match bit to '0' indicates that the corresponding field is used in the match process. Depending on the match bits, the alarm occurs as specifically as once a month or as frequently as once every minute. Selecting none of the match bits (all 1s) indicates that no match is required and therefore, alarm is disabled. Selecting all match bits (all 0s) causes an exact time and date match.

There are two ways to detect an alarm event: by reading the AF flag or monitoring the INT pin. The AF flag in the flags register at 0x00 indicates that a date or time match has occurred. The AF bit is set to '1' when a match occurs. Reading the flags register clears the alarm flag bit (and all others). A hardware interrupt pin may also be used to detect an alarm event.

To set, clear or enable an alarm, set the 'W' bit (in flags register - 0x00) to '1' to enable writes to alarm registers. After writing the alarm value, clear the 'W' bit back to '0' for the changes to take effect.

Note CY14X256I requires the alarm match bit for seconds (bit 'D7' in Alarm-Seconds register 0x02) to be set to '0' for proper operation of Alarm Flag and Interrupt.

Watchdog Timer

The watchdog timer is a free running down counter that uses the 32 Hz clock (31.25 ms) derived from the crystal oscillator. The oscillator must be running for the watchdog to function. It begins counting down from the value loaded in the watchdog timer register.

The timer consists of a loadable register and a free running counter. On power-up, the watchdog time out value in register 0x07 is loaded into the Counter Load register. Counting begins on power-up and restarts from the loadable value any time the Watchdog Strobe (WDS) bit is set to '1'. The counter is compared to the terminal value of '0'. If the counter reaches this value, it causes an internal flag and an optional interrupt output. You can prevent the time out interrupt by setting WDS bit to '1' prior to the counter reaching '0'. This causes the counter to reload with the watchdog time out value and to be restarted. As long as the user sets the WDS bit prior to the counter reaching the terminal value, the interrupt and WDT flag never occur.

New time out values are written by setting the watchdog write bit to '0'. When the WDW is '0', new writes to the watchdog time out value bits D5-D0 are enabled to modify the time out value. When WDW is '1', writes to bits D5-D0 are ignored. The WDW function enables a user to set the WDS bit without concern that the watchdog timer value is modified. A logical diagram of the watchdog timer is shown in [Figure 36 on page 22](#). Note that

setting the watchdog time out value to '0' disables the watchdog function.

The output of the watchdog timer is the flag bit WDF that is set if the watchdog is allowed to time out. If the watchdog interrupt enable (WIE) bit in the Interrupt register is set, a hardware interrupt on INT pin is also generated on watchdog timeout. The flag and the hardware interrupt are both cleared when user reads the flag registers.

Figure 36. Watchdog Timer Block Diagram

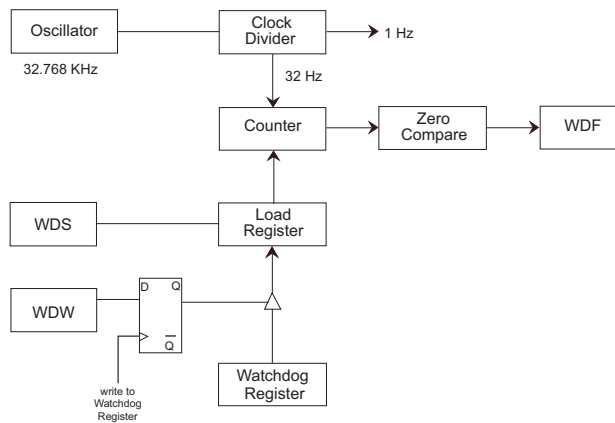

Programmable Square Wave Generator

The square wave generator block uses the crystal output to generate a desired frequency on the INT pin of the device. The output frequency can be programmed to be one of the following:

1. 1 Hz
2. 512 Hz
3. 4096 Hz
4. 32768 Hz

The square wave output is not generated while the device is running on backup power.

Power Monitor

The CY14X256I provides a power management scheme with power fail interrupt capability. It also controls the internal switch to back up power for the clock and protects the memory from low V_{CC} access. The power monitor is based on an internal band gap reference circuit that compares the V_{CC} voltage to V_{SWITCH} threshold.

When V_{SWITCH} is reached, as V_{CC} decays from power loss, a data store operation is initiated from SRAM to the nonvolatile elements, securing the last SRAM data state. Power is also switched from V_{CC} to the backup supply (battery or capacitor) to operate the RTC oscillator.

When operating from the backup source, read and write operations to nvSRAM are inhibited and the RTC functions are not available to the user. The RTC clock continues to operate in the background. The updated RTC time keeping registers are available to the user after V_{CC} is restored to the device (see [nvSRAM Specifications on page 34](#)).

Backup Power Monitor

The CY14X256I provides a backup power monitoring system that detects the backup power (either battery or capacitor backup) failure. The backup power fail flag (BPF) is issued on the next power-up in case of backup power failure. The BPF flag is set in the event of backup voltage falling lower than $V_{BAKFAIL}$. The backup power is monitored even while the RTC is running in backup mode. Low voltage detected during backup mode is flagged through the BPF flag. BPF can hold the data only until a defined low level of the back up voltage (V_{DR}).

Interrupts

The CY14X256I has a flags register, interrupt register, and interrupt logic that can signal interrupt to the microcontroller. There are three potential sources for interrupt: watchdog timer, power monitor, and alarm timer. Each of these can be individually enabled to drive the INT pin by appropriate setting in the interrupt register (0x06). In addition, each has an associated flag bit in the flags register (0x00) that the host processor uses to determine the cause of the interrupt. The INT pin driver has two bits that specify its behavior when an interrupt occurs.

An interrupt is raised only if both a flag is raised by one of the three sources and the respective interrupt enable bit in interrupts register is enabled (set to '1'). After an interrupt source is active, two programmable bits, H/L and P/L, determine the behavior of the output pin driver on INT pin. These two bits are located in the Interrupt register and can be used to drive level or pulse mode output from the INT pin. In pulse mode, the pulse width is internally fixed at approximately 200 ms. This mode is intended to reset a host microcontroller. In the level mode, the pin goes to its active polarity until the flags register is read by the user. This mode is used as an interrupt to a host microcontroller. The control bits are summarized in the following section.

Interrupts are only generated while working on normal power and are not triggered when system is running in backup power mode.

Note CY14X256I generates valid interrupts only after the Powerup RECALL sequence is completed. All events on INT pin must be ignored for t_{FA} duration after powerup.

Interrupt Register

Watchdog Interrupt Enable (WIE): When set to '1', the watchdog timer drives the INT pin and an internal flag when a watchdog time out occurs. When WIE is set to '0', the watchdog timer only affects the WDF flag in flags register.

Alarm Interrupt Enable (AIE): When set to '1', the alarm match drives the INT pin and an internal flag. When AIE is set to '0', the alarm match only affects the AF flag in the flags register.

Power Fail Interrupt Enable (PFE): When set to '1', the power fail monitor drives the pin and an internal flag. When PFE is set to '0', the power fail monitor only affects the PF flag in the flags register.

Square Wave Enable (SQWE): When set to '1', a square wave of programmable frequency is generated on the INT pin. The frequency is decided by the SQ1 and SQ0 bits of the interrupts register. This bit is nonvolatile and survives power cycle. The SQWE bit overrides all other interrupts. However, CAL bit will take precedence over the square wave generator. This bit defaults to '0' from the factory.

High/Low (H/L): When set to a '1', the INT pin is active HIGH and the driver mode is push pull. The INT pin drives HIGH only when V_{CC} is greater than V_{SWITCH} . When set to a '0', the INT pin is active LOW and the drive mode is open drain. The INT pin must be pulled up to V_{CC} by a 10 k resistor while using the interrupt in active LOW mode.

Pulse/Level (P/L): When set to a '1' and an interrupt occurs, the INT pin is driven for approximately 200 ms. When P/L is set to a '0', the INT pin is driven HIGH or LOW (determined by H/L) until the flags register is read.

SQ1 and SQ0. These bits are used together to fix the frequency of square wave on INT pin output when SQWE bit is set to '1'. These bits are nonvolatile and survive power cycle. The output frequency is decided as illustrated in this table.

Table 8. SQW Output Selection

| SQ1 | SQ0 | Frequency | Comment |
|-----|-----|-----------|-----------------------------|
| 0 | 0 | 1 Hz | 1 Hz signal |
| 0 | 1 | 512 Hz | 512 Hz clock output |
| 1 | 0 | 4096 Hz | 4 kHz clock output |
| 1 | 1 | 32768 Hz | Oscillator output frequency |

When an enabled interrupt source activates the INT pin, an external host reads the flag registers to determine the cause. Remember that all flags are cleared when the register is read. If the INT pin is programmed for Level mode, then the condition

clears and the INT pin returns to its inactive state. If the pin is programmed for Pulse mode, then reading the flag also clears the flag and the pin. The pulse does not complete its specified duration if the flags register is read. If the INT pin is used as a host reset, the flags register is not read during a reset.

Following is a summary table that shows the state of the INT pin,

Table 9. State of the INT pin

| CAL | SQWE | WIE/AIE/PFE | INT Pin Output |
|-----|------|-------------|--------------------|
| 1 | X | X | 512 Hz |
| 0 | 1 | X | Square wave output |
| 0 | 0 | 1 | Alarm |
| 0 | 0 | 0 | HI-Z |

Flags Register

The flags register has three flag bits: WDF, AF, and PF, which can be used to generate an interrupt. These flags are set by the watchdog timeout, alarm match, or power fail monitor respectively. The processor can either poll this register or enable interrupts to be informed when a flag is set. These flags are automatically reset after the register is read. The flags register is automatically loaded with the value 0x00 on power-up (except for the OSCF bit. See [Stopping and Starting the Oscillator on page 20](#)).

Figure 37. Interrupt Block Diagram

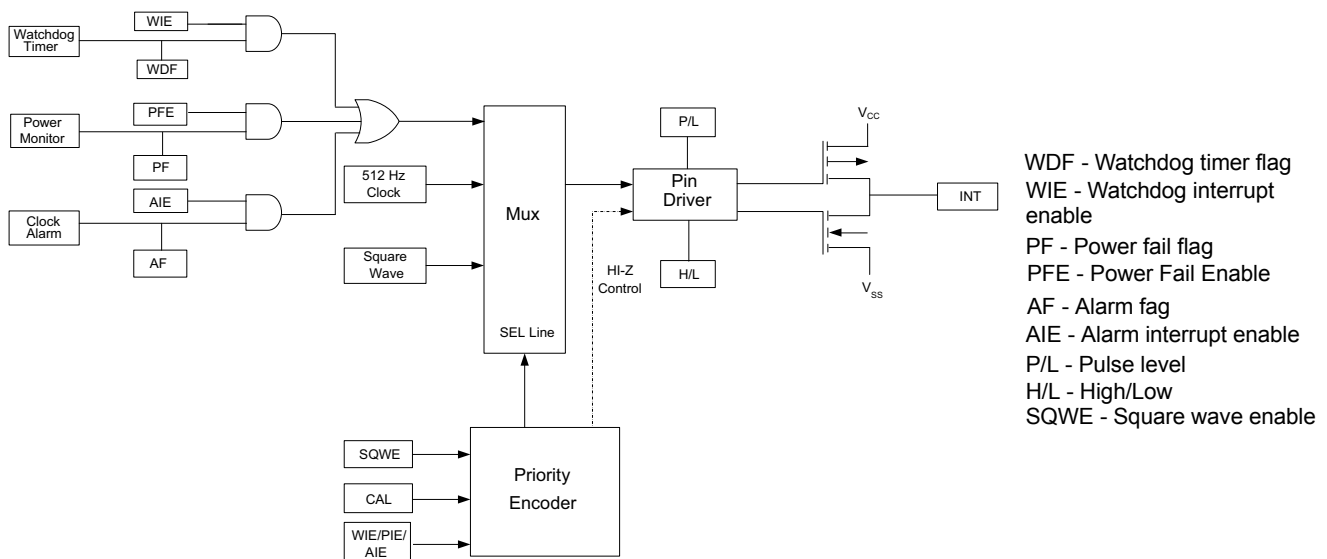

RTC External Components

The RTC requires connecting an external 32.768 kHz crystal and C_1 , C_2 load capacitance as shown in the [Figure 38](#). The figure shows the recommended RTC external component values. The

load capacitances C_1 and C_2 are inclusive of parasitic of the printed circuit board (PCB). The PCB parasitic includes the capacitance due to land pattern of crystal pads/pins, X_{in}/X_{out} pads and copper traces connecting crystal and device pins.

Figure 38. RTC Recommended Component Configuration ^[4]

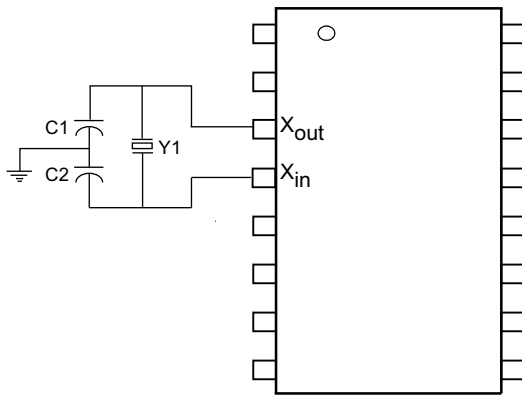

Recommended Values

$Y1 = 32.768 \text{ KHz (12.5 pF)}$

$C_1 = 12 \text{ pF}$

$C_2 = 69 \text{ pF}$

Note: The recommended values for C_1 and C_2 include board trace capacitance.

Note

- For nonvolatile static random access memory (nvSRAM) real time clock (RTC) design guidelines and best practices, refer application note [AN61546](#).

PCB Design Considerations for RTC

RTC crystal oscillator is a low current circuit with high impedance nodes on their crystal pins. Due to lower timekeeping current of RTC, the crystal connections are very sensitive to noise on the board. Hence it is necessary to isolate the RTC circuit from other signals on the board.

It is also critical to minimize the stray capacitance on the PCB. Stray capacitances add to the overall crystal load capacitance and therefore cause oscillation frequency errors. Proper bypassing and careful layout are required to achieve the optimum RTC performance.

Layout requirements

The board layout must adhere to (but not limited to) the following guidelines during routing RTC circuitry. Following these guidelines help you achieve optimum performance from the RTC design.

- It is important to place the crystal as close as possible to the X_{in} and X_{out} pins. Keep the trace lengths between the crystal and RTC equal in length and as short as possible to reduce the probability of noise coupling by reducing the length of the antenna.

- Keep X_{in} and X_{out} trace width lesser than 8 mils. Wider trace width leads to larger trace capacitance. The larger these bond pads and traces are, the more likely it is that noise can couple from adjacent signals.
- Shield the X_{in} and X_{out} signals by providing a guard ring around the crystal circuitry. This guard ring prevents noise coupling from neighboring signals.
- Take care while routing any other high speed signal in the vicinity of RTC traces. The more the crystal is isolated from other signals on the board, the less likely it is that noise is coupled into the crystal. Maintain a minimum of 200 mil separation between the X_{in} , X_{out} traces and any other high speed signal on the board.
- No signals should run underneath crystal components on the same PCB layer.
- Create an isolated solid copper plane on adjacent PCB layer and underneath the crystal circuitry to prevent unwanted noise coupled from traces routed on the other signal layers of the PCB. The local plane should be separated by at least 40 mils from the neighboring plane on the same PCB layer. The solid plane should be in the vicinity of RTC components only and its perimeter should be kept equal to the guard ring perimeter. [Figure 39](#) shows the recommended layout for RTC circuit.

Figure 39. Recommended Layout for RTC

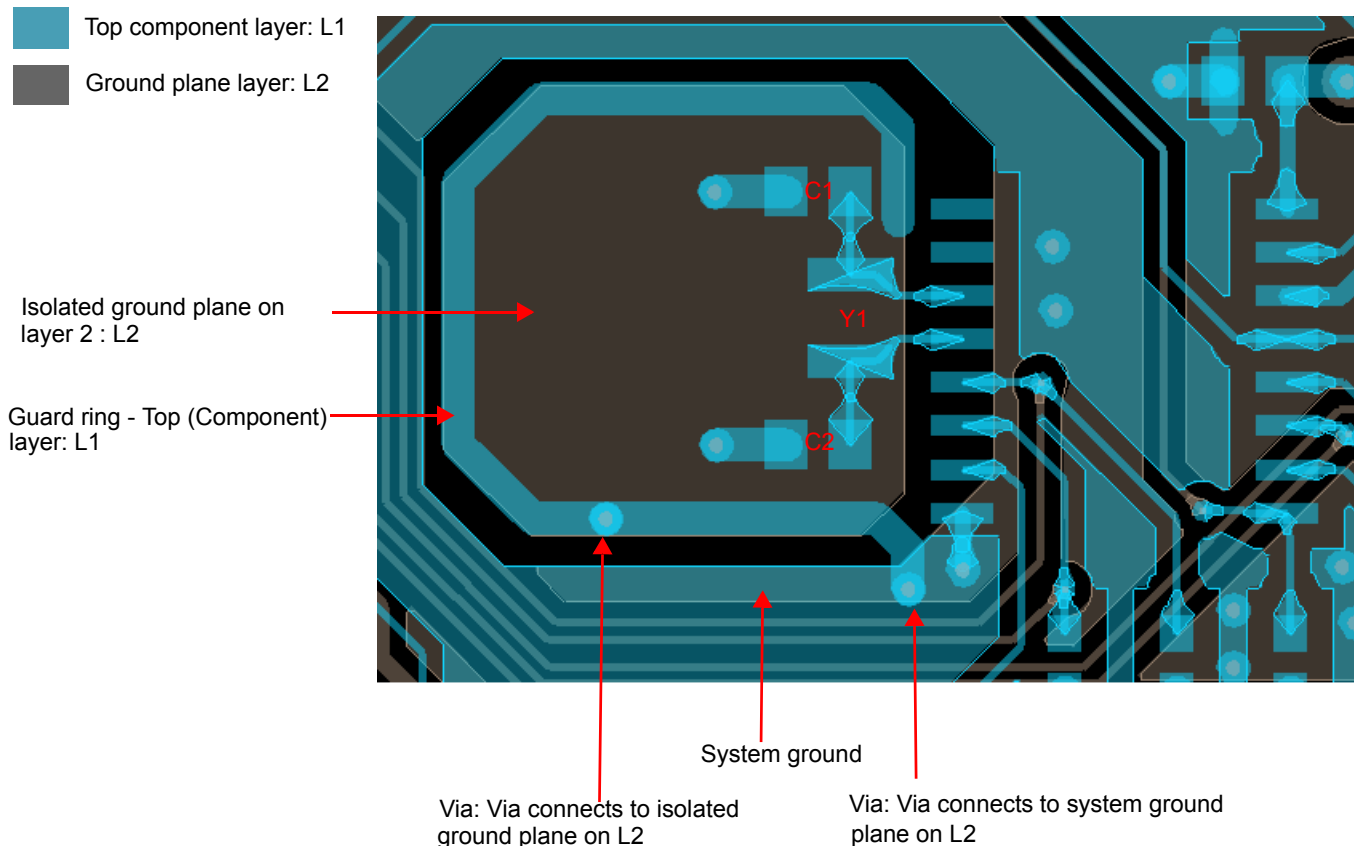



Table 10. RTC Register Map ^[5, 6]

| Register | BCD Format Data | | | | | | | | Function/Range |
|----------|-----------------|-------------------|------------------|---------------------|--------------------|-------------|---------|---------|-----------------------------------|
| | D7 | D6 | D5 | D4 | D3 | D2 | D1 | D0 | |
| 0x0F | 10s years | | | | Years | | | | Years: 00–99 |
| 0x0E | 0 | 0 | 0 | 10s months | Months | | | | Months: 01–12 |
| 0x0D | 0 | 0 | 10s day of month | | Day of month | | | | Day of month: 01–31 |
| 0x0C | 0 | 0 | 0 | 0 | 0 | Day of week | | | Day of week: 01–07 |
| 0x0B | 0 | 0 | 10s hours | | Hours | | | | Hours: 00–23 |
| 0x0A | 0 | 10s minutes | | | Minutes | | | | Minutes: 00–59 |
| 0x09 | 0 | 10s seconds | | | Seconds | | | | Seconds: 00–59 |
| 0x08 | OSCEN (0) | 0 | Cal Sign (0) | Calibration (00000) | | | | | Calibration Values ^[7] |
| 0x07 | WDS (0) | WDW (0) | WDT (000000) | | | | | | Watchdog ^[7] |
| 0x06 | WIE (0) | AIE (0) | PFE (0) | SQWE (0) | H/L (1) | P/L (0) | SQ1 (0) | SQ0 (0) | Interrupts ^[7] |
| 0x05 | M (1) | 0 | 10s alarm date | | Alarm day | | | | Alarm, day of month: 01–31 |
| 0x04 | M (1) | 0 | 10s alarm hours | | Alarm hours | | | | Alarm, hours: 00–23 |
| 0x03 | M (1) | 10s alarm minutes | | | Alarm minutes | | | | Alarm, minutes: 00–59 |
| 0x02 | M (1) | 10s alarm seconds | | | Alarm seconds | | | | Alarm, seconds: 00–59 |
| 0x01 | 10s centuries | | | | Centuries | | | | Centuries: 00–99 |
| 0x00 | WDF | AF | PF | OSCF ^[8] | BPF ^[8] | CAL (0) | W (0) | R (0) | Flags ^[7] |

Notes

5. () designates values shipped from the factory.
6. The unused bits of RTC registers are reserved for future use and should be set to '0'.
7. This is a binary value, not a BCD value.
8. When user resets OSCF and BPF flag bits, the flags register will be updated after t_{RTCp} time.

Table 11. Register Map Detail

| Register | Description | | | | | | | |
|------------------|--|-------------|------------------|-------------|--------------|-------------|----|----|
| 0x0F | Time Keeping - Years | | | | | | | |
| | D7 | D6 | D5 | D4 | D3 | D2 | D1 | D0 |
| | 10s years | | | | Years | | | |
| | Contains the lower two BCD digits of the year. Lower nibble (four bits) contains the value for years; upper nibble (four bits) contains the value for 10s of years. Each nibble operates from 0 to 9. The range for the register is 0–99. | | | | | | | |
| 0x0E | Time Keeping - Months | | | | | | | |
| | D7 | D6 | D5 | D4 | D3 | D2 | D1 | D0 |
| | 0 | 0 | 0 | 10s month | Months | | | |
| | Contains the BCD digits of the month. Lower nibble (four bits) contains the lower digit and operates from 0 to 9; upper nibble (one bit) contains the upper digit and operates from 0 to 1. The range for the register is 1–12. | | | | | | | |
| 0x0D | Time Keeping - Date | | | | | | | |
| | D7 | D6 | D5 | D4 | D3 | D2 | D1 | D0 |
| | 0 | 0 | 10s day of month | | Day of month | | | |
| | Contains the BCD digits for the date of the month. Lower nibble (four bits) contains the lower digit and operates from 0 to 9; upper nibble (two bits) contains the 10s digit and operates from 0 to 3. The range for the register is 1–31. Leap years are automatically adjusted for. | | | | | | | |
| 0x0C | Time Keeping - Day | | | | | | | |
| | D7 | D6 | D5 | D4 | D3 | D2 | D1 | D0 |
| | 0 | 0 | 0 | 0 | 0 | Day of week | | |
| | Lower nibble (three bits) contains a value that correlates to day of the week. Day of the week is a ring counter that counts from 1 to 7 then returns to 1. The user must assign meaning to the day value, because the day is not integrated with the date. | | | | | | | |
| 0x0B | Time Keeping - Hours | | | | | | | |
| | D7 | D6 | D5 | D4 | D3 | D2 | D1 | D0 |
| | 0 | 0 | 10s hours | | Hours | | | |
| | Contains the BCD value of hours in 24 hour format. Lower nibble (four bits) contains the lower digit and operates from 0 to 9; upper nibble (two bits) contains the upper digit and operates from 0 to 2. The range for the register is 0–23. | | | | | | | |
| 0x0A | Time Keeping - Minutes | | | | | | | |
| | D7 | D6 | D5 | D4 | D3 | D2 | D1 | D0 |
| | 0 | 10s minutes | | | Minutes | | | |
| | Contains the BCD value of minutes. Lower nibble (four bits) contains the lower digit and operates from 0 to 9; upper nibble (three bits) contains the upper minutes digit and operates from 0 to 5. The range for the register is 0–59. | | | | | | | |
| 0x09 | Time Keeping - Seconds | | | | | | | |
| | D7 | D6 | D5 | D4 | D3 | D2 | D1 | D0 |
| | 0 | 10s seconds | | | Seconds | | | |
| | Contains the BCD value of seconds. Lower nibble (four bits) contains the lower digit and operates from 0 to 9; upper nibble (three bits) contains the upper digit and operates from 0 to 5. The range for the register is 0–59. | | | | | | | |
| 0x08 | Calibration/Control | | | | | | | |
| | D7 | D6 | D5 | D4 | D3 | D2 | D1 | D0 |
| | OSCEN | 0 | Calibration sign | Calibration | | | | |
| OSCEN | Oscillator Enable. When set to '1', the oscillator is stopped. When set to '0', the oscillator runs. Disabling the oscillator saves battery or capacitor power during storage. | | | | | | | |
| Calibration Sign | Determines if the calibration adjustment is applied as an addition (1) to or as a subtraction (0) from the time-base. | | | | | | | |

Table 11. Register Map Detail (continued)

| Register | Description | | | | | | | |
|---|--|-----------|-----------------|-----------|-----------|-------------|-----------|-----------|
| Calibration | These five bits control the calibration of the clock. | | | | | | | |
| 0x07 | Watchdog Timer | | | | | | | |
| | D7 | D6 | D5 | D4 | D3 | D2 | D1 | D0 |
| | WDS | WDW | WDT | | | | | |
| WDS | Watchdog Strobe. Setting this bit to '1' reloads and restarts the watchdog timer. Setting the bit to '0' has no effect. The bit is cleared automatically after the watchdog timer is reset. The WDS bit is write only. Reading it always returns a 0. | | | | | | | |
| WDW | Watchdog Write Enable. Setting this bit to '1' disables any WRITE to the watchdog timeout value (D5–D0). This enables the user to set the watchdog strobe bit without disturbing the timeout value. Setting this bit to '0' allows bits D5–D0 to be written to the watchdog register when the next write cycle is complete. This function is explained in more detail in Watchdog Timer on page 21 . | | | | | | | |
| WDT | Watchdog timeout selection. The watchdog timer interval is selected by the 6-bit value in this register. It represents a multiplier of the 32 Hz count (31.25 ms). The range of timeout value is 31.25 ms (a setting of 1) to 2 seconds (setting of 3 Fh). Setting the watchdog timer register to '0' disables the timer. These bits can be written only if the WDW bit was set to 0 on a previous cycle. | | | | | | | |
| 0x06 | Interrupt Status/Control | | | | | | | |
| | D7 | D6 | D5 | D4 | D3 | D2 | D1 | D0 |
| | WIE | AIE | PFE | SQWE | H/L | P/L | SQ1 | SQ0 |
| WIE | Watchdog Interrupt Enable. When set to '1' and a watchdog timeout occurs, the watchdog timer drives the INT pin and the WDF flag. When set to '0', the watchdog timeout affects only the WDF flag. | | | | | | | |
| AIE | Alarm Interrupt Enable. When set to '1', the alarm match drives the INT pin and the AF flag. When set to '0', the alarm match only affects the AF flag. | | | | | | | |
| PFE | Power Fail Enable. When set to '1', the alarm match drives the INT pin and the PF flag. When set to '0', the power fail monitor affects only the PF flag. | | | | | | | |
| SQWE | Square Wave Enable. When set to '1', a square wave is driven on the INT pin with frequency programmed using SQ1 and SQ0 bits. The square wave output takes precedence over interrupt logic. If the SQWE bit is set to '1', when an enabled interrupt source becomes active, only the corresponding flag is raised and the INT pin continues to drive the square wave. | | | | | | | |
| H/L | High/Low. When set to '1', the INT pin is driven active HIGH. When set to '0', the INT pin is open drain, active LOW. | | | | | | | |
| P/L | Pulse/Level. When set to '1', the INT pin is driven active (determined by H/L) by an interrupt source for approximately 200 ms. When set to '0', the INT pin is driven to an active level (as set by H/L) until the flags register is read. | | | | | | | |
| SQ1, SQ0 | SQ1, SQ0. These bits are used to decide the frequency of the Square wave on the INT pin output when SQWE bit is set to '1'. The following is the frequency output for each combination of (SQ1, SQ0): (0, 0) - 1 Hz (0, 1) - 512 Hz (1, 0) - 4096 Hz (1, 1) - 32768 Hz | | | | | | | |
| 0x05 | Alarm - Day | | | | | | | |
| | D7 | D6 | D5 | D4 | D3 | D2 | D1 | D0 |
| | M | 0 | 10s alarm date | | | Alarm date | | |
| Contains the alarm value for the date of the month and the mask bit to select or deselect the date value. | | | | | | | | |
| M | Match. When this bit is set to '0', the date value is used in the alarm match. Setting this bit to '1' causes the match circuit to ignore the date value. | | | | | | | |
| 0x04 | Alarm - Hours | | | | | | | |
| | D7 | D6 | D5 | D4 | D3 | D2 | D1 | D0 |
| | M | 0 | 10s alarm hours | | | Alarm hours | | |
| Contains the alarm value for the hours and the mask bit to select or deselect the hours value. | | | | | | | | |
| M | Match. When this bit is set to '0', the hours value is used in the alarm match. Setting this bit to '1' causes the match circuit to ignore the hours value. | | | | | | | |



Table 11. Register Map Detail (continued)

| Register | Description | | | | | | | |
|----------|---|-------------------|----|------|-----------|---------------|----|----|
| 0x03 | Alarm - Minutes | | | | | | | |
| | D7 | D6 | D5 | D4 | D3 | D2 | D1 | D0 |
| | M | 10s alarm minutes | | | | Alarm minutes | | |
| | Contains the alarm value for the minutes and the mask bit to select or deselect the minutes value. | | | | | | | |
| M | Match. When this bit is set to '0', the minutes value is used in the alarm match. Setting this bit to '1' causes the match circuit to ignore the minutes value. | | | | | | | |
| 0x02 | Alarm - Seconds | | | | | | | |
| | D7 | D6 | D5 | D4 | D3 | D2 | D1 | D0 |
| | M | 10s alarm seconds | | | | Alarm seconds | | |
| | Contains the alarm value for the seconds and the mask bit to select or deselect the seconds' value. | | | | | | | |
| M | Match. When this bit is set to '0', the seconds value is used in the alarm match. Setting this bit to '1' causes the match circuit to ignore the seconds value. | | | | | | | |
| 0x01 | Time Keeping - Centuries | | | | | | | |
| | D7 | D6 | D5 | D4 | D3 | D2 | D1 | D0 |
| | 10s centuries | | | | Centuries | | | |
| | Contains the BCD value of centuries. Lower nibble contains the lower digit and operates from 0 to 9; upper nibble contains the upper digit and operates from 0 to 9. The range for the register is 0-99 centuries. | | | | | | | |
| 0x00 | Flags | | | | | | | |
| | D7 | D6 | D5 | D4 | D3 | D2 | D1 | D0 |
| | WDF | AF | PF | OSCF | BPF | CAL | W | R |
| WDF | Watchdog Timer Flag. This read only bit is set to '1' when the watchdog timer is allowed to reach '0' without being reset by the user. It is cleared to '0' when the flags register is read or on power-up | | | | | | | |
| AF | Alarm Flag. This read only bit is set to '1' when the time and date match the values stored in the alarm registers with the match bits = '0'. It is cleared when the flags register is read or on power-up. | | | | | | | |
| PF | Power Fail Flag. This read only bit is set to '1' when power falls below the power fail threshold V_{SWITCH} . It is cleared when the flags register is read. | | | | | | | |
| OSCF | Oscillator Fail Flag. Set to '1' on power-up if the oscillator is enabled and not running in the first 5 ms of operation. This indicates that RTC backup power failed and clock value is no longer valid. This bit survives power cycle and is never cleared internally by the chip. The user must check for this condition and write '0' to clear this flag. When user resets OSCF flag bit, the bit will be updated after t_{RTCp} time. | | | | | | | |
| BPF | Backup Power Fail Flag. Set to '1' on power-up if the backup power (battery or capacitor) failed. The backup power fail condition is determined by the voltage falling below their respective minimum specified voltage. BPF can hold the data only till a defined low level of the back up voltage (V_{DR}). User must reset this bit to clear this flag. When user resets BPF flag bit, the bit will be updated after t_{RTCp} time. | | | | | | | |
| CAL | Calibration Mode. When set to '1', a 512 Hz square wave is output on the INT pin. When set to '0', the INT pin resumes normal operation. This bit takes priority than SQ0/SQ1 and other functions. This bit defaults to '0' (disabled) on power-up. | | | | | | | |
| W | Write Enable: Setting the 'W' bit to '1' freezes updates of the RTC registers. The user can then write to RTC registers, alarm registers, calibration register, interrupt register and flags register. Setting the 'W' bit to '0' causes the contents of the RTC registers to be transferred to the time keeping counters if the time has changed. This transfer process takes t_{RTCp} time to complete. This bit defaults to 0 on power-up. | | | | | | | |
| R | Read Enable: Setting 'R' bit to '1', stops clock updates to user RTC registers so that clock updates are not seen during the reading process. Set 'R' bit to '0' to resume clock updates to the holding register. Setting this bit does not require 'W' bit to be set to '1'. This bit defaults to '0' on power-up. | | | | | | | |



Maximum Ratings

Exceeding maximum ratings may shorten the useful life of the device. These user guidelines are not tested.

Storage temperature -65 °C to +150 °C

Maximum accumulated storage time

At 150 °C ambient temperature 1000 h

At 85 °C ambient temperature 20 Years

Maximum junction temperature 150 °C

Supply voltage on V_{CC} relative to V_{SS}

CY14C256I: -0.5 V to +3.1 V

CY14B256I: -0.5 V to +4.1 V

CY14E256I: -0.5 V to +7.0 V

DC voltage applied to outputs

in high Z state -0.5 V to $V_{CC} + 0.5 V$

Input voltage -0.5 V to $V_{CC} + 0.5 V$

Transient voltage (< 20 ns) on any pin to ground potential -2.0 V to $V_{CC} + 2.0 V$

Package power dissipation capability ($T_A = 25 °C$) 1.0 W

Surface mount lead soldering temperature (3 seconds) +260 °C

DC output current (1 output at a time, 1s duration) 15 mA

Static discharge voltage (per MIL-STD-883, Method 3015) > 2001 V

Latch up current > 140 mA

Operating Range

| Product | Range | Ambient Temperature | V_{CC} |
|-----------|------------|---------------------|----------------|
| CY14C256I | Industrial | -40 °C to +85 °C | 2.4 V to 2.6 V |
| CY14B256I | | | 2.7 V to 3.6 V |
| CY14E256I | | | 4.5 V to 5.5 V |

DC Electrical Characteristics

Over the [Operating Range](#)

| Parameter | Description | Test Conditions | Min | Typ ^[9] | Max | Unit | |
|-----------------|--|--|-----------|--------------------|-----|---------------|---------------|
| V_{CC} | Power supply | CY14C256I | 2.4 | 2.5 | 2.6 | V | |
| | | CY14B256I | 2.7 | 3.0 | 3.6 | V | |
| | | CY14E256I | 4.5 | 5.0 | 5.5 | V | |
| I_{CC1} | Average V_{CC} current | $f_{SCL} = 3.4 \text{ MHz}$; Values obtained without output loads ($I_{OUT} = 0 \text{ mA}$) | - | - | 1 | mA | |
| | | $f_{SCL} = 1 \text{ MHz}$; Values obtained without output loads ($I_{OUT} = 0 \text{ mA}$) | CY14C256I | - | - | 400 | μA |
| | | | CY14E256I | - | - | 450 | μA |
| I_{CC2} | Average V_{CC} current during STORE | All inputs don't care, $V_{CC} = \text{max}$ Average current for duration t_{STORE} | - | - | 3 | mA | |
| I_{CC4} | Average V_{CAP} current during AutoStore cycle | All inputs don't care. Average current for duration t_{STORE} | - | - | 3 | mA | |
| I_{SB} | V_{CC} standby current | $SCL \geq (V_{CC} - 0.2 \text{ V})$. $V_{IN} \leq 0.2 \text{ V}$ or $\geq (V_{CC} - 0.2 \text{ V})$. 'W' bit set to '0'. Standby current level after nonvolatile cycle is complete. Inputs are static. $f_{SCL} = 0 \text{ MHz}$. | - | - | 250 | μA | |
| I_{ZZ} | Sleep mode current | t_{SLEEP} time after SLEEP Instruction is registered. All inputs are static and configured at CMOS logic level. | - | - | 8 | μA | |
| $I_{IX}^{[10]}$ | Input current in each I/O pin (except HSB) | $0.1 V_{CC} < V_i < 0.9 V_{CC} \text{ max}$ | -1 | - | +1 | μA | |
| | Input current in each I/O pin (for HSB) | | -100 | - | +1 | μA | |
| I_{OZ} | Output leakage current | | -1 | - | +1 | μA | |

Notes

9. Typical values are at 25 °C, $V_{CC} = V_{CC(TYP)}$. Not 100% tested.

10. Not applicable to WP, A2, A1 and A0 pins.



DC Electrical Characteristics (continued)

Over the [Operating Range](#)

| Parameter | Description | Test Conditions | Min | Typ ^[9] | Max | Unit | |
|--|--|---|------------------------|--------------------|-----------------------|-----------------------|----|
| C _i | Capacitance for each I/O pin | Capacitance measured across all input and output signal pin and V _{SS} . | – | – | 7 | pF | |
| V _{IH} | Input HIGH voltage | | 0.7 × V _{CC} | – | V _{CC} + 0.5 | V | |
| V _{IL} | Input LOW voltage | | – 0.5 | – | 0.3 × V _{CC} | V | |
| V _{OL} | Output LOW voltage | I _{OL} = 3 mA | 0 | – | 0.4 | V | |
| | | I _{OL} = 6 mA | 0 | – | 0.6 | V | |
| R _{in} ^[11] | Input resistance (WP, A2, A1, A0) | For V _{IN} = V _{IL} (Max) | 50 | – | – | KΩ | |
| | | For V _{IN} = V _{IH} (Min) | 1 | – | – | MΩ | |
| V _{hys} | Hysteresis of Schmitt trigger inputs | | 0.05 × V _{CC} | – | – | V | |
| V _{CAP} ^[12] | Storage capacitor | Between V _{CAP} pin and V _{SS} | CY14C256I | 170 | 220 | 270 | μF |
| | | | CY14B256I CY14E256I | 42 | 47 | 180 | μF |
| V _{V_{CAP}} ^[13, 14] | Maximum voltage driven on V _{CAP} pin by the device | V _{CC} = Max | CY14C256I CY14B256I | – | – | V _{CC} | V |
| | | | CY14E256I | – | – | V _{CC} – 0.5 | V |

Data Retention and Endurance

Over the [Operating Range](#)

| Parameter | Description | Min | Unit |
|-------------------|------------------------------|-------|-------|
| DATA _R | Data retention | 20 | Years |
| NV _C | Nonvolatile STORE operations | 1,000 | K |

Thermal Resistance

| Parameter ^[13] | Description | Test Conditions | 16-pin SOIC | Unit |
|---------------------------|--|---|-------------|------|
| θ _{JA} | Thermal resistance (junction to ambient) | Test conditions follow standard test methods and procedures for measuring thermal impedance, according to EIA / JESD51. | 56.68 | °C/W |
| θ _{JC} | Thermal resistance (junction to case) | | 32.11 | °C/W |

Notes

- The input pull-down circuit is stronger (50 kΩ) when the input voltage is below V_{IL} and weak (1 MΩ) when the input voltage is above V_{IH}.
- Min V_{CAP} value guarantees that there is a sufficient charge available to complete a successful AutoStore operation. Max V_{CAP} value guarantees that the capacitor on V_{CAP} is charged to a minimum voltage during a Power-Up RECALL cycle so that an immediate power-down cycle can complete a successful AutoStore. Therefore it is always recommended to use a capacitor within the specified min and max limits. Refer application note [AN43593](#) for more details on V_{CAP} options.
- Maximum voltage on V_{CAP} pin (V_{V_{CAP}}) is provided for guidance when choosing the V_{CAP} capacitor. The voltage rating of the V_{CAP} capacitor across the operating temperature range should be higher than the V_{V_{CAP}} voltage.
- These parameters are guaranteed by design and are not tested.

AC Test Loads and Waveforms

Figure 40. AC Test Loads and Waveforms

For 2.5 V (CY14C256I)

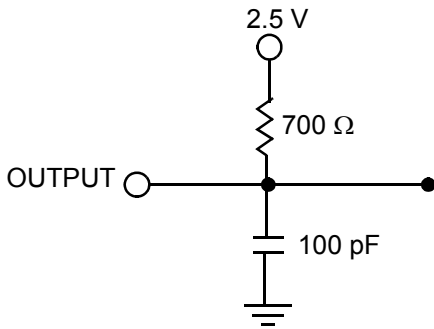

For 3.0 V (CY14B256I)

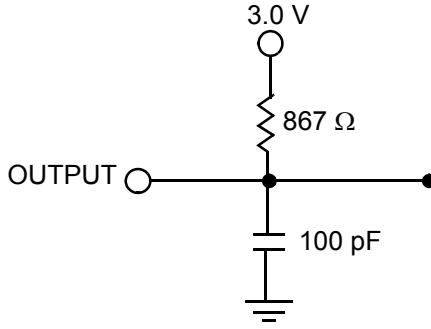

For 5.0 V (CY14E256I)

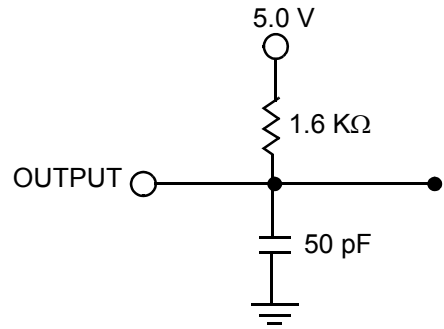

AC Test Conditions

| Description | CY14C256I | CY14B256I | CY14E256I |
|--|--------------|------------|------------|
| Input pulse levels | 0 V to 2.5 V | 0 V to 3 V | 0 V to 5 V |
| Input rise and fall times (10%–90%) | 10 ns | 10 ns | 10 ns |
| Input and output timing reference levels | 1.25 V | 1.5 V | 2.5 V |

RTC Characteristics

Over the [Operating Range](#)

| Parameter | Description | Min | Typ | Max | Units | |
|---------------------|---|-------------|-----|------|----------|---------|
| V_{RTCbat} | RTC battery pin voltage | 1.8 | – | 3.6 | V | |
| $I_{BAK}^{[15]}$ | RTC backup current (Refer Figure 38 for the recommended external components for RTC) | T_A (Min) | – | – | 0.45 | μA |
| | | 25 °C | – | 0.45 | – | μA |
| | | T_A (Max) | – | – | 0.60 | μA |
| $V_{RTCcap}^{[16]}$ | RTC capacitor pin voltage | T_A (Min) | 1.6 | – | 3.6 | V |
| | | 25 °C | 1.5 | 3.0 | 3.6 | V |
| | | T_A (Max) | 1.4 | – | 3.6 | V |
| $V_{BAKFAIL}$ | Backup failure threshold | 1.8 | – | 2.2 | V | |
| V_{DR} | BPF flag retention voltage | 1.6 | – | – | V | |
| t_{OCS} | RTC oscillator time to start | – | 1 | 2 | sec | |
| t_{RTCp} | RTC processing time from end of 'W' bit set to '0' | – | – | 1 | ms | |
| R_{BKCHG} | RTC backup capacitor charge current-limiting resistor | 350 | – | 850 | Ω | |

Notes

15. Current drawn from either V_{RTCcap} or V_{RTCbat} when $V_{CC} < V_{SWITCH}$.

16. If $V_{RTCcap} > 0.5$ V or if no capacitor is connected to V_{RTCcap} pin, the oscillator will start in t_{OCS} time. If a backup capacitor is connected and $V_{RTCcap} < 0.5$ V, the capacitor must be allowed to charge to 0.5 V for oscillator to start.

AC Switching Characteristics

Over the [Operating Range](#)

| Parameter ^[17] | Description | 3.4 MHz ^[18] | | 1 MHz ^[18] | | 400 kHz ^[18] | | Unit |
|---------------------------|---|-------------------------|------|-----------------------|------|-------------------------|-----|------|
| | | Min | Max | Min | Max | Min | Max | |
| f_{SCL} | Clock frequency, SCL | – | 3400 | – | 1000 | – | 400 | kHz |
| $t_{SU;STA}$ | Setup time for Repeated START condition | 160 | – | 250 | – | 600 | – | ns |
| $t_{HD;STA}$ | Hold time for START condition | 160 | – | 250 | – | 600 | – | ns |
| t_{LOW} | LOW period of the SCL | 160 | – | 500 | – | 1300 | – | ns |
| t_{HIGH} | HIGH period of the SCL | 60 | – | 260 | – | 600 | – | ns |
| $t_{SU;DATA}$ | Data in setup time | 10 | – | 100 | – | 100 | – | ns |
| $t_{HD;DATA}$ | Data hold time (In/Out) | 0 | – | 0 | – | 0 | – | ns |
| t_{DH} | Data out hold time | 0 | – | 0 | – | 0 | – | ns |
| $t_r^{[19]}$ | Rise time of SDA and SCL | – | 80 | – | 120 | – | 300 | ns |
| $t_f^{[19]}$ | Fall time of SDA and SCL | – | 80 | – | 120 | – | 300 | ns |
| $t_{SU;STO}$ | Setup time for STOP condition | 160 | – | 250 | – | 600 | – | ns |
| $t_{VD;DATA}$ | Data output valid time | – | 130 | – | 400 | – | 900 | ns |
| $t_{VD;ACK}$ | ACK output valid time | – | 130 | – | 400 | – | 900 | ns |
| $t_{OF}^{[19]}$ | Output fall time from $V_{IH\ min}$ to $V_{IL\ max}$ | – | 80 | – | 120 | – | 250 | ns |
| t_{BUF} | Bus free time between STOP and next START condition | 0.3 | – | 0.5 | – | 1.3 | – | us |
| t_{SP} | Pulse width of spikes that must be suppressed by input filter | – | 10 | – | 50 | – | 50 | ns |

Switching Waveforms

Figure 41. Timing Diagram

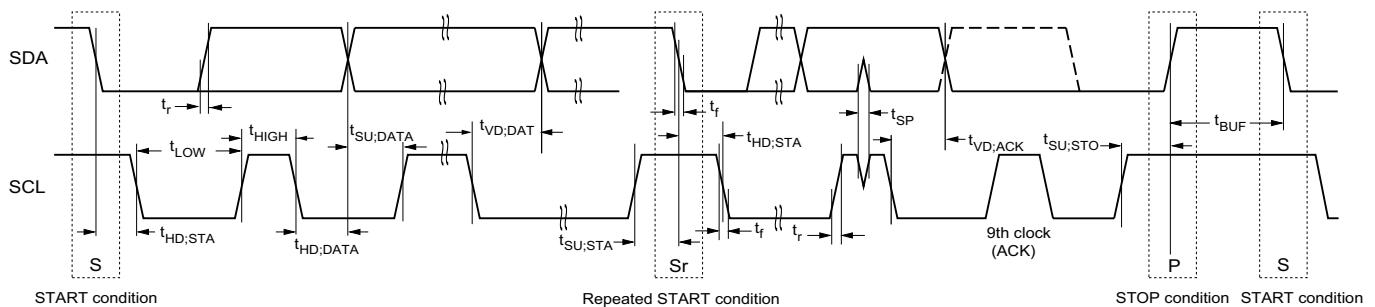

Note

17. Test conditions assume signal transition time of 10 ns or less, timing reference levels of $V_{CC}/2$, input pulse levels of 0 to $V_{CC(typ)}$, and output loading of the specified I_{OL} and load capacitance shown in [Figure 40](#).
18. Bus Load (C_b) considerations; $C_b < 500$ pF for I²C clock frequency (SCL) 100/400 KHz; $C_b < 550$ pF for SCL at 1000 kHz; $C_b < 100$ pF for SCL at 3.4 MHz.
19. These parameters are guaranteed by design and are not tested.



nvSRAM Specifications

Over the [Operating Range](#)

| Parameter | Description | | Min | Max | Unit |
|-----------------------|--|-----------|-----|------|---------|
| $t_{FA}^{[20]}$ | Power-up RECALL duration | CY14C256I | – | 40 | ms |
| | | CY14B256I | – | 20 | ms |
| | | CY14E256I | – | 20 | ms |
| $t_{STORE}^{[21]}$ | STORE cycle duration | | – | 8 | ms |
| $t_{DELAY}^{[22]}$ | Time allowed to complete SRAM write cycle | | – | 25 | ns |
| $t_{VCCRRISE}^{[23]}$ | V_{CC} rise time | | 150 | – | μ s |
| V_{SWITCH} | Low voltage trigger level | CY14C256I | – | 2.35 | V |
| | | CY14B256I | – | 2.65 | V |
| | | CY14E256I | – | 4.40 | V |
| $t_{LZHSB}^{[23]}$ | HSB high to nvSRAM active time | | – | 5 | μ s |
| $V_{HDIS}^{[23]}$ | HSB output disable voltage | | – | 1.9 | V |
| $t_{HHHD}^{[23]}$ | HSB HIGH active time | | – | 500 | ns |
| t_{WAKE} | Time for nvSRAM to wake up from SLEEP mode | CY14C256I | – | 40 | ms |
| | | CY14B256I | – | 20 | ms |
| | | CY14E256I | – | 20 | ms |
| t_{SLEEP} | Time to enter low power mode after issuing SLEEP instruction | | – | 8 | ms |
| $t_{SB}^{[23]}$ | Time to enter into standby mode after issuing STOP condition | | – | 100 | μ s |

Switching Waveforms

Figure 42. AutoStore or Power-Up RECALL [24]

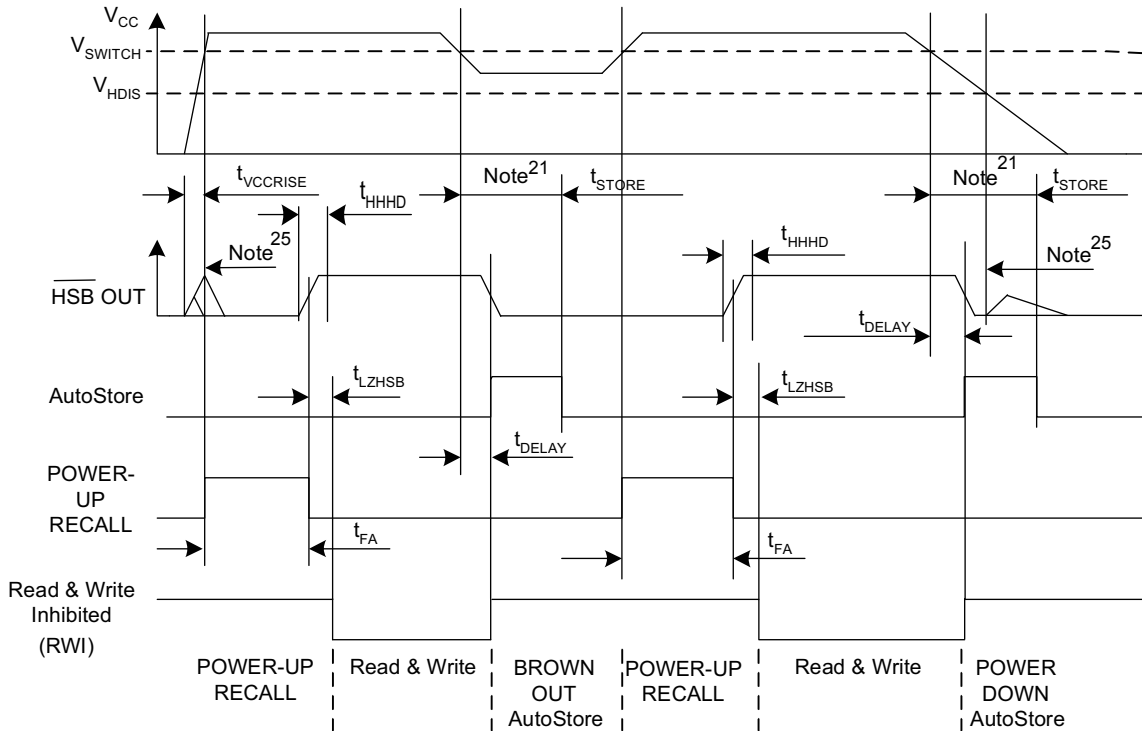

Notes

- 20. t_{FA} starts from the time V_{CC} rises above V_{SWITCH} .
- 21. If an SRAM write has not taken place since the last nonvolatile cycle, no AutoStore or Hardware STORE takes place.
- 22. On a Hardware STORE and AutoStore initiation, SRAM write operation continues to be enabled for time t_{DELAY} .
- 23. These parameters are guaranteed by design and are not tested.
- 24. Read and Write cycles are ignored during STORE, RECALL, and while V_{CC} is below V_{SWITCH} .
- 25. During power-up and power-down, HSB glitches when HSB pin is pulled up through an external resistor.

Software Controlled STORE/RECALL Cycles

Over the [Operating Range](#)

| Parameter | Description | CY14X256I | | Unit |
|----------------------------|-----------------------------------|-----------|-----|---------------|
| | | Min | Max | |
| t_{RECALL} | RECALL duration | – | 600 | μs |
| $t_{\text{SS}}^{[26, 27]}$ | Software sequence processing time | – | 500 | μs |

Switching Waveforms

Figure 43. Software STORE/RECALL Cycle

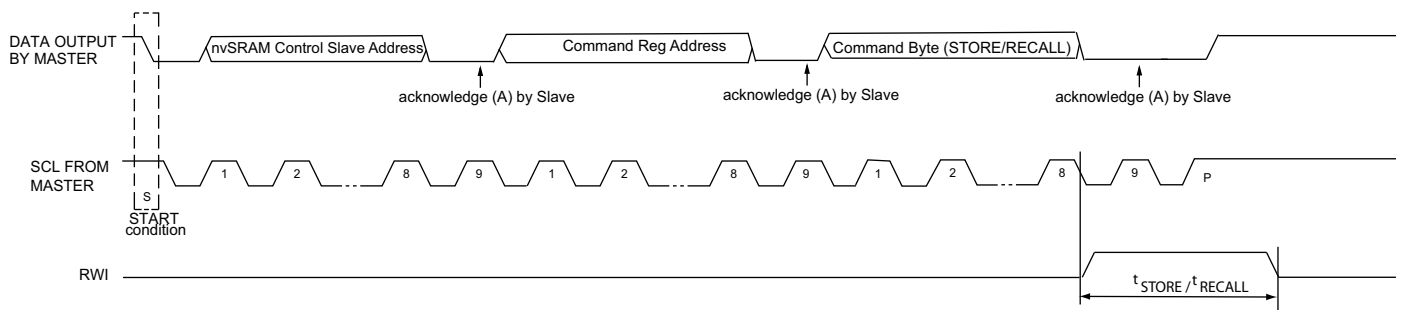
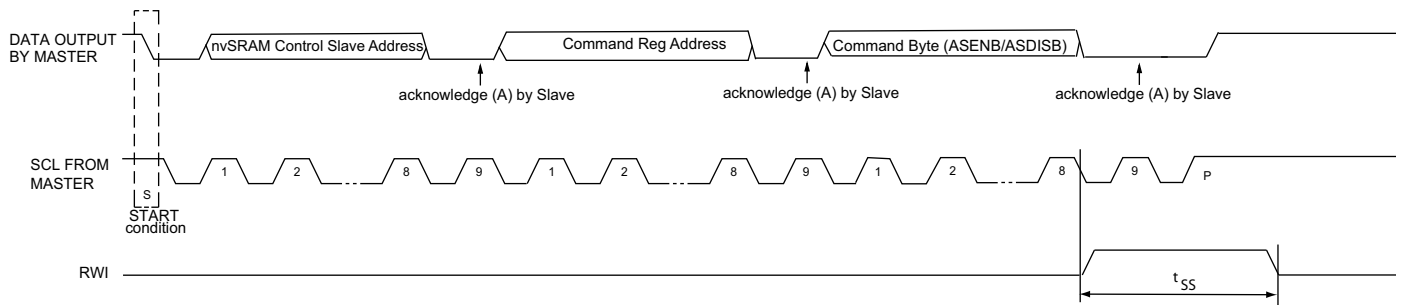

Figure 44. AutoStore Enable/Disable Cycle



Notes

26. This is the amount of time it takes to take action on a soft sequence command. Vcc power must remain HIGH to effectively register command.
 27. Commands such as STORE and RECALL lock out I/O until operation is complete which further increases this time. See the specific command.

Hardware STORE Cycle

Over the [Operating Range](#)

| Parameter | Description | CY14X256I | | Unit |
|------------|----------------------------|-----------|-----|------|
| | | Min | Max | |
| t_{PHSB} | Hardware STORE pulse width | 15 | – | ns |

Switching Waveforms

Figure 45. Hardware STORE Cycle ^[28]

Write Latch set

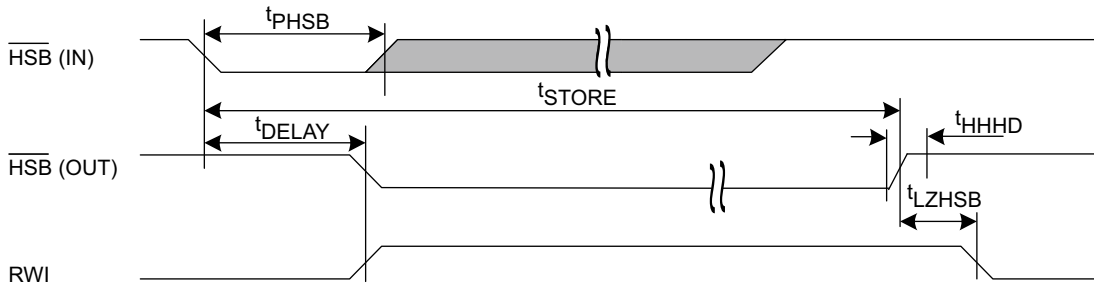

Write Latch not set

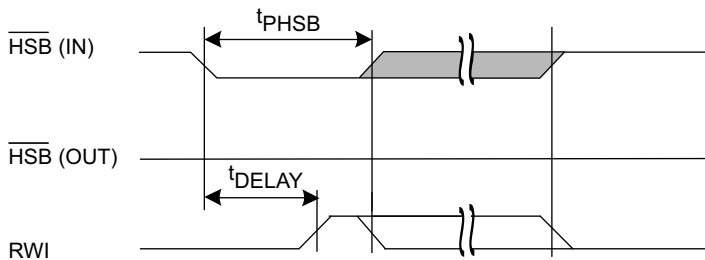

HSB pin is driven HIGH to V_{CC} only by Internal 100 K Ω resistor, HSB driver is disabled
 SRAM is disabled as long as HSB (IN) is driven LOW.

Note

28. If an SRAM write has not taken place since the last nonvolatile cycle, no AutoStore or Hardware STORE takes place.

Ordering Information

| Ordering Code | Package Diagram | Package Type | Operating Range |
|-----------------|-----------------|--------------|-----------------|
| CY14B256I-SFXI | 51-85022 | 16-pin SOIC | Industrial |
| CY14B256I-SFXIT | | | |

The above part is Pb-free. This table contains Final information. Contact your local Cypress sales representative for availability of these parts.

Ordering Code Definitions

CY 14 B 256 I - SF X I T

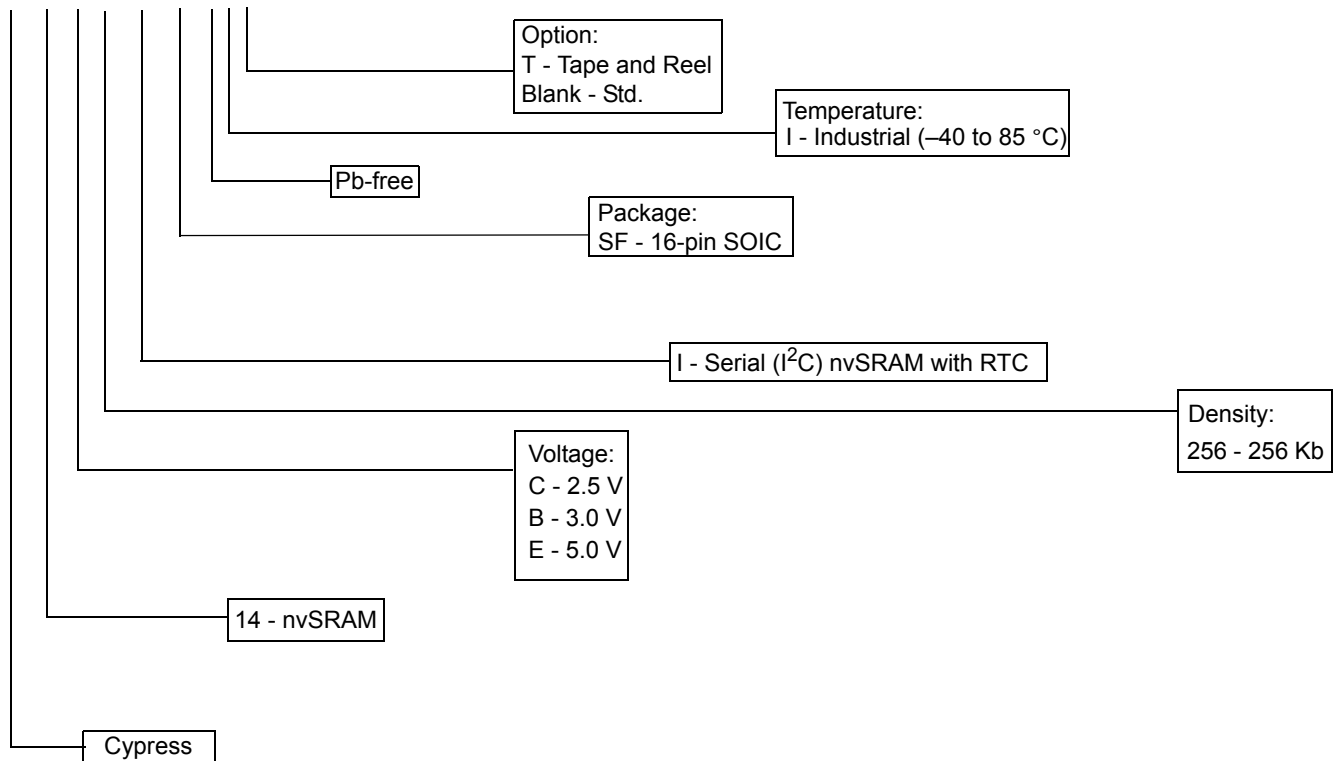

Package Diagram

Figure 46. 16-pin SOIC (0.413 × 0.299 × 0.0932) Inches Package Outline, 51-85022

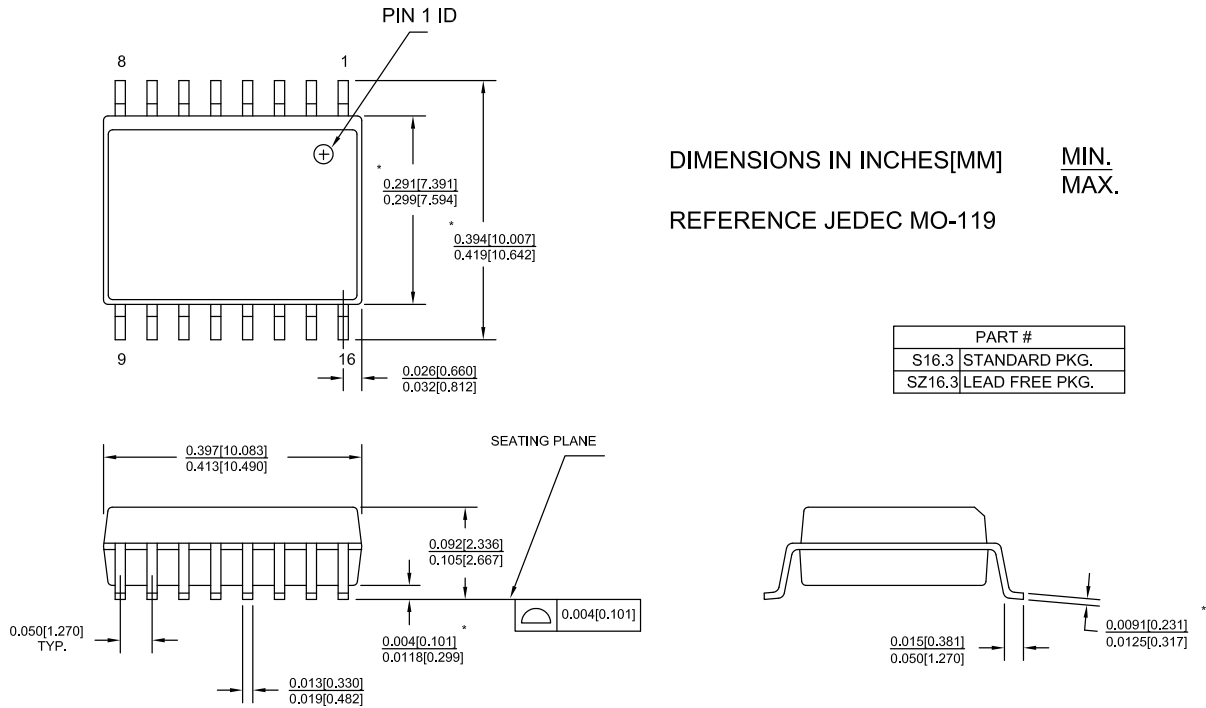

51-85022 *E



Acronyms

| Acronym | Description |
|------------------|--|
| ACK | Acknowledge |
| BCD | Binary Coded Decimal |
| CMOS | Complementary Metal Oxide Semiconductor |
| CRC | Cyclic Redundancy Check |
| EIA | Electronic Industries Alliance |
| I ² C | Inter-Integrated Circuit Bus |
| I/O | Input/Output |
| JEDEC | Joint Electron Devices Engineering Council |
| LSB | Least Significant Bit |
| MSB | Most Significant Bit |
| nvSRAM | Non-volatile Static Random Access Memory |
| OSCF | Oscillator Fail Flag |
| PCB | Printed circuit board |
| RoHS | Restriction of Hazardous Substances |
| R/W | Read/Write |
| RTC | Real Time Clock |
| RWI | Read and Write Inhibited |
| SCL | Serial Clock Line |
| SDA | Serial Data Line |
| SNL | Serial Number Lock |
| SOIC | Small Outline Integrated Circuit |
| SRAM | Static Random Access Memory |
| WP | Write Protect |

Document Conventions

Units of Measure

| Symbol | Unit of Measure |
|--------|-------------------|
| °C | degree Celsius |
| F | farad |
| Hz | hertz |
| kHz | kilohertz |
| kΩ | kilohm |
| MHz | megahertz |
| MΩ | megaohm |
| μA | microampere |
| μF | microfarad |
| μs | microsecond |
| mA | milliampere |
| ms | millisecond |
| ns | nanosecond |
| Ω | ohm |
| pF | picofarad |
| ppm | parts per million |
| V | volt |
| W | watt |



Document History Page

| Document Title: CY14C256I, CY14B256I, CY14E256I, 256-Kbit (32 K × 8) Serial (I ² C) nvSRAM with Real Time Clock Document Number: 001-65230 | | | | |
|--|---------|-----------------|-----------------|---|
| Rev. | ECN No. | Submission Date | Orig. of Change | Description of Change |
| ** | 3089600 | 11/18/2010 | GVCH | New data sheet. |
| *A | 3197569 | 03/16/2011 | GVCH | Updated AutoStore Operation (description). Updated Hardware STORE and HSB pin Operation (Added more clarity on HSB pin operation). Updated Table 6 (Product ID column). Updated Setting the Clock (description). Updated Figure (C1, C2 values to 12pF, 69pF from 10pF, 67pF respectively). Updated Table 11 ('W' bit description). Updated . Updated RTC Characteristics (Added t_{RTCp} parameter). Updated nvSRAM Specifications (description of t_{LZHSB} parameter). Fixed Typo error in Figure 42 . Updated in new template. |
| *B | 3248510 | 05/05/2011 | GVCH | Datasheet status changed from "Preliminary" to "Final" |
| *C | 3394987 | 11/28/2011 | GVCH | Updated Pin Definitions (SDA pin description). Added footnote 3 Updated Command Register (SLEEP description on page 9). Updated Device ID (Added device ID (4 bytes) column in Table 6). Updated Executing Commands Using Command Register (description). Added footnote 4 Updated DC Electrical Characteristics (Added I_{CC1} parameter value for 1 MHz frequency, changed I_{CC2} parameter value from 2 mA to 3 mA, removed I_{CC3} parameter, added Note 12 and referred the note in the V_{CAP} parameter). Updated RTC Characteristics table Updated AC Switching Characteristics (added Note 17 and referred the note in the Parameter column, updated t_{SP} max value from 5 ns to 10 ns for 3.4 MHz). Updated Software Controlled STORE/RECALL Cycles (Updated Figure 43 and Figure 44). Updated Package Diagram . |
| *D | 3676259 | 07/25/2012 | GVCH | Updated Real Time Clock Operation (description). Updated DC Electrical Characteristics (Added $V_{V_{CAP}}$ parameter and its details, added Note 13 and referred the same note in $V_{V_{CAP}}$ parameter, also referred Note 14 in $V_{V_{CAP}}$ parameter). |
| *E | 3757434 | 09/27/2012 | GVCH | Updated Maximum Ratings (Removed "Ambient temperature with power applied" and included "Maximum junction temperature"). |
| *F | 3905097 | 02/15/2013 | GVCH | Updated Features : Added Note 1 and referred the same note in "High-speed I ² C interface". |
| *G | 3985313 | 05/02/2013 | GVCH | Updated Features : Updated Note 1 . Updated DC Electrical Characteristics : Added one more condition " $I_{OL} = 6$ mA" for V_{OL} parameter and added respective values. Updated RTC Characteristics : Changed maximum value of $V_{BAKFAIL}$ parameter from 2 V to 2.2 V. Updated AC Switching Characteristics : Updated Note 18 . Changed value of t_{OF} parameter from 300 ns to 250 ns for 400 kHz frequency. Updated Package Diagram : spec 51-85022 – Changed revision from *D to *E. |

Document History Page

| Document Title: CY14C256I, CY14B256I, CY14E256I, 256-Kbit (32 K × 8) Serial (I ² C) nvSRAM with Real Time Clock | | | | |
|--|---------|-----------------|-----------------|--|
| Document Number: 001-65230 | | | | |
| Rev. | ECN No. | Submission Date | Orig. of Change | Description of Change |
| *H | 4039592 | 06/25/2013 | GVCH | Updated Real Time Clock Operation : Updated Backup Power (Added Note). Added RTC External Components . Moved Figure 38 from Flags Register section to RTC External Components section. Added PCB Design Considerations for RTC . Updated in new template. |
| *I | 4567905 | 11/12/2014 | GVCH | Added related documentation hyperlink in page 1. |
| *J | 6033841 | 01/16/2018 | GVCH | Updated to the new template. Completing the Sunset review. |



Sales, Solutions, and Legal Information

Worldwide Sales and Design Support

Cypress maintains a worldwide network of offices, solution centers, manufacturer's representatives, and distributors. To find the office closest to you, visit us at [Cypress Locations](#).

Products

| | |
|---|--|
| Arm [®] Cortex [®] Microcontrollers | cypress.com/arm |
| Automotive | cypress.com/automotive |
| Clocks & Buffers | cypress.com/clocks |
| Interface | cypress.com/interface |
| Internet of Things | cypress.com/iot |
| Memory | cypress.com/memory |
| Microcontrollers | cypress.com/mcu |
| PSoC | cypress.com/psoc |
| Power Management ICs | cypress.com/pmic |
| Touch Sensing | cypress.com/touch |
| USB Controllers | cypress.com/usb |
| Wireless Connectivity | cypress.com/wireless |

PSoC[®] Solutions

[PSoC 1](#) | [PSoC 3](#) | [PSoC 4](#) | [PSoC 5LP](#) | [PSoC 6 MCU](#)

Cypress Developer Community

[Community](#) | [Projects](#) | [Video](#) | [Blogs](#) | [Training](#) | [Components](#)

Technical Support

cypress.com/support

© Cypress Semiconductor Corporation, 2010-2018. This document is the property of Cypress Semiconductor Corporation and its subsidiaries, including Spansion LLC ("Cypress"). This document, including any software or firmware included or referenced in this document ("Software"), is owned by Cypress under the intellectual property laws and treaties of the United States and other countries worldwide. Cypress reserves all rights under such laws and treaties and does not, except as specifically stated in this paragraph, grant any license under its patents, copyrights, trademarks, or other intellectual property rights. If the Software is not accompanied by a license agreement and you do not otherwise have a written agreement with Cypress governing the use of the Software, then Cypress hereby grants you a personal, non-exclusive, nontransferable license (without the right to sublicense) (1) under its copyright rights in the Software (a) for Software provided in source code form, to modify and reproduce the Software solely for use with Cypress hardware products, only internally within your organization, and (b) to distribute the Software in binary code form externally to end users (either directly or indirectly through resellers and distributors), solely for use on Cypress hardware product units, and (2) under those claims of Cypress's patents that are infringed by the Software (as provided by Cypress, unmodified) to make, use, distribute, and import the Software solely for use with Cypress hardware products. Any other use, reproduction, modification, translation, or compilation of the Software is prohibited.

TO THE EXTENT PERMITTED BY APPLICABLE LAW, CYPRESS MAKES NO WARRANTY OF ANY KIND, EXPRESS OR IMPLIED, WITH REGARD TO THIS DOCUMENT OR ANY SOFTWARE OR ACCOMPANYING HARDWARE, INCLUDING, BUT NOT LIMITED TO, THE IMPLIED WARRANTIES OF MERCHANTABILITY AND FITNESS FOR A PARTICULAR PURPOSE. No computing device can be absolutely secure. Therefore, despite security measures implemented in Cypress hardware or software products, Cypress does not assume any liability arising out of any security breach, such as unauthorized access to or use of a Cypress product. In addition, the products described in these materials may contain design defects or errors known as errata which may cause the product to deviate from published specifications. To the extent permitted by applicable law, Cypress reserves the right to make changes to this document without further notice. Cypress does not assume any liability arising out of the application or use of any product or circuit described in this document. Any information provided in this document, including any sample design information or programming code, is provided only for reference purposes. It is the responsibility of the user of this document to properly design, program, and test the functionality and safety of any application made of this information and any resulting product. Cypress products are not designed, intended, or authorized for use as critical components in systems designed or intended for the operation of weapons, weapons systems, nuclear installations, life-support devices or systems, other medical devices or systems (including resuscitation equipment and surgical implants), pollution control or hazardous substances management, or other uses where the failure of the device or system could cause personal injury, death, or property damage ("Unintended Uses"). A critical component is any component of a device or system whose failure to perform can be reasonably expected to cause the failure of the device or system, or to affect its safety or effectiveness. Cypress is not liable, in whole or in part, and you shall and hereby do release Cypress from any claim, damage, or other liability arising from or related to all Unintended Uses of Cypress products. You shall indemnify and hold Cypress harmless from and against all claims, costs, damages, and other liabilities, including claims for personal injury or death, arising from or related to any Unintended Uses of Cypress products.

Cypress, the Cypress logo, Spansion, the Spansion logo, and combinations thereof, WICED, PSoC, CapSense, EZ-USB, F-RAM, and Traveo are trademarks or registered trademarks of Cypress in the United States and other countries. For a more complete list of Cypress trademarks, visit cypress.com. Other names and brands may be claimed as property of their respective owners.

Компания «Океан Электроники» предлагает заключение долгосрочных отношений при поставках импортных электронных компонентов на взаимовыгодных условиях!

Наши преимущества:

- Поставка оригинальных импортных электронных компонентов напрямую с производств Америки, Европы и Азии, а так же с крупнейших складов мира;
- Широкая линейка поставок активных и пассивных импортных электронных компонентов (более 30 млн. наименований);
- Поставка сложных, дефицитных, либо снятых с производства позиций;
- Оперативные сроки поставки под заказ (от 5 рабочих дней);
- Экспресс доставка в любую точку России;
- Помощь Конструкторского Отдела и консультации квалифицированных инженеров;
- Техническая поддержка проекта, помощь в подборе аналогов, поставка прототипов;
- Поставка электронных компонентов под контролем ВП;
- Система менеджмента качества сертифицирована по Международному стандарту ISO 9001;
- При необходимости вся продукция военного и аэрокосмического назначения проходит испытания и сертификацию в лаборатории (по согласованию с заказчиком);
- Поставка специализированных компонентов военного и аэрокосмического уровня качества (Xilinx, Altera, Analog Devices, Intersil, Interpoint, Microsemi, Actel, Aeroflex, Peregrine, VPT, Syfer, Eurofarad, Texas Instruments, MS Kennedy, Miteq, Cobham, E2V, MA-COM, Hittite, Mini-Circuits, General Dynamics и др.);

Компания «Океан Электроники» является официальным дистрибьютором и эксклюзивным представителем в России одного из крупнейших производителей разъемов военного и аэрокосмического назначения «JONHON», а так же официальным дистрибьютором и эксклюзивным представителем в России производителя высокотехнологичных и надежных решений для передачи СВЧ сигналов «FORSTAR».



JONHON

«JONHON» (основан в 1970 г.)

Разъемы специального, военного и аэрокосмического назначения:

(Применяются в военной, авиационной, аэрокосмической, морской, железнодорожной, горно- и нефтедобывающей отраслях промышленности)

«FORSTAR» (основан в 1998 г.)

ВЧ соединители, коаксиальные кабели,
кабельные сборки и микроволновые компоненты:

(Применяются в телекоммуникациях гражданского и специального назначения, в средствах связи, РЛС, а так же военной, авиационной и аэрокосмической отраслях промышленности).



Телефон: 8 (812) 309-75-97 (многоканальный)

Факс: 8 (812) 320-03-32

Электронная почта: ocean@oceanchips.ru

Web: <http://oceanchips.ru/>

Адрес: 198099, г. Санкт-Петербург, ул. Калинина, д. 2, корп. 4, лит. А