

APPROVAL SHEET

WW12X, WW08X, WW06X, WW04X

±1%, ±5%

Low ohmic chip resistors

Size 1206, 0805, 0603, 0402

Customer : _____
Approval No : _____
Issue Date : _____

Customer Approval :



FEATURE

1. High power rating and compact size
2. High reliability and stability
3. Reduced size of final equipment
4. Lead free product is upon customer requested.

APPLICATION

- Power supply
- PDA
- Digital meter
- Computer
- Automotives
- Battery charger
- DC-DC power converter

DESCRIPTION

The resistors are constructed in a high grade ceramic body (aluminum oxide). Internal metal electrodes are added at each end and connected by a resistive paste that is applied to the top surface of the substrate. The composition of the paste is adjusted to give the approximate resistance required and the value is trimmed to nominated value within tolerance which controlled by laser trimming of this resistive layer.

The resistive layer is covered with a protective coat. Finally, the two external end terminations are added. For ease of soldering the outer layer of these end terminations is a Lead-tin or Tin (lead free) alloy.

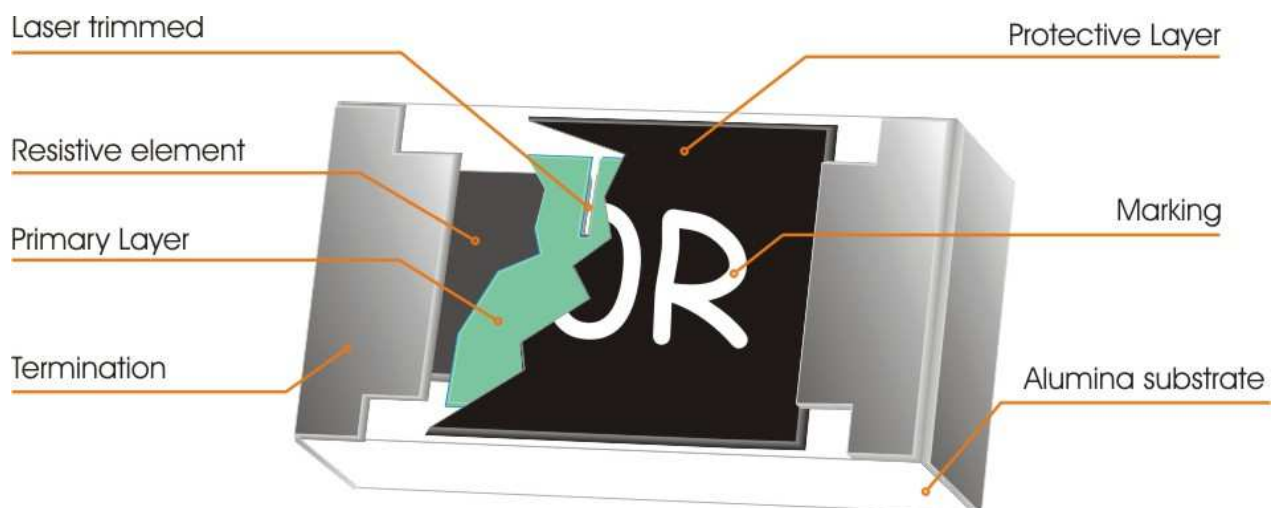

Fig 1. Construction of Chip-R



QUICK REFERENCE DATA

Item	General Specification			
Series No.	WW12X	WW08X	WW06X	WW04X
Size code	1206 (3216)	0805 (2012)	0603 (1608)	0402(1005)
Resistance Tolerance	±5%, ±1%			
Resistance Range	0.02Ω ~ 0.976Ω		0.10Ω ~ 0.976Ω	
TCR (ppm/°C)	0.02Ω ≤ Rn < 0.05Ω	≤ 2100 ppm/°C	≤ 1500 ppm/°C	N/a
	0.05Ω ≤ Rn < 0.10Ω	≤ 1000 ppm/°C	≤ 1000 ppm/°C	N/a
	0.10Ω ≤ Rn < 0.50Ω	≤ 500 ppm/°C	≤ 500 ppm/°C	≤ 500 ppm/°C
	0.50Ω ≤ Rn < 1Ω	≤ 400 ppm/°C	≤ 300 ppm/°C	≤ 600 ppm/°C
Max. dissipation at T _{amb} =70°C	1/4 W	1/8 W	1/10 W	1/16 W
Max. Operation Voltage (DC or RMS)	200V	100V	50V	
Climatic category (IEC 60068)	55/155/56			

Note :

1. This is the maximum voltage that may be continuously supplied to the resistor element, see “IEC publication 60115-8”
2. Max. Operation Voltage : So called RCWV (Rated Continuous Working Voltage) is determined by

$$RCWV = \sqrt{\text{Rated Power} \times \text{Resistance Value}}$$
or Max. RCWV listed above, whichever is lower.
3. Tolerance of TCR=±200ppm/°C
4. Lead free product is upon customer requested.

MECHANICAL DATA

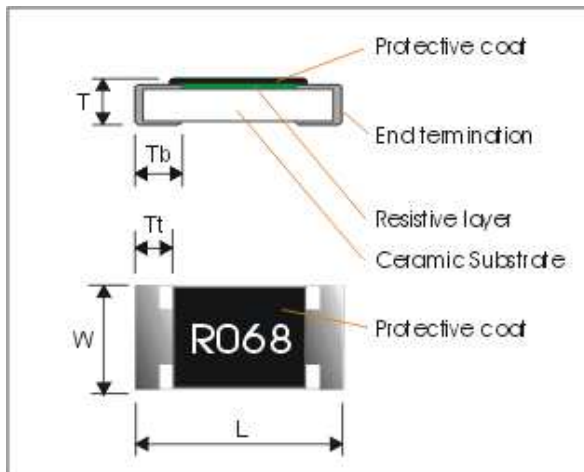

Symbol	WW12X	WW08X	WW06X	WW04X
L	3.10 ± 0.10	2.00 ± 0.10	1.60 ± 0.10	1.00 ± 0.05
W	1.60 ± 0.10	1.25 ± 0.10	0.80 ± 0.10	0.50 ± 0.05
T	0.60 ± 0.15	0.50 ± 0.15	0.45 ± 0.15	0.35 ± 0.05
Tt	0.50 ± 0.20	0.40 ± 0.20	0.30 ± 0.10	0.20 ± 0.10
Tb	0.45 ± 0.20	0.40 ± 0.20	0.30 ± 0.20	0.25 ± 0.10



MARKING

- **4-digits marking for 1206, 0805 size**

Each resistor is marked with a four-digit code on the protective coating to designate the nominal resistance value.

- **3-digits marking for 0603 size**

Each resistor is marked with a three -digit code on the protective coating to designate the nominal resistance value.

- WW04X series has no marking on the product overcoat for both 5% & 1%.

FUNCTIONAL DESCRIPTION

Product characterization

Standard values of nominal resistance are taken from the E96 & E24 series for resistors with a tolerance of $\pm 5\%$ & $\pm 1\%$. The values of the E24/E96 series are in accordance with "IEC publication 60063".

Derating curve

The power that the resistor can dissipate depends on the operating temperature; see Fig.2

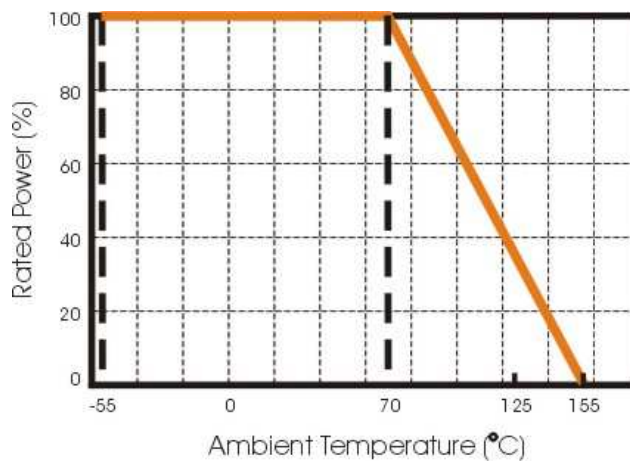

Figure 2 Maximum dissipation in percentage of rated power as a function of the ambient temperature

MOUNTING

Due to their rectangular shapes and small tolerances, Surface Mountable Resistors are suitable for handling by automatic placement systems.

Chip placement can be on ceramic substrates and printed-circuit boards (PCBs).

Electrical connection to the circuit is by individual soldering condition.

The end terminations guarantee a reliable contact.



SOLDERING CONDITION

The robust construction of chip resistors allows them to be completely immersed in a solder bath of 260°C for 10 seconds. Therefore, it is possible to mount Surface Mount Resistors on one side of a PCB and other discrete components on the reverse (mixed PCBs).

Surface Mount Resistors are tested for solderability at 245°C during 3 seconds. The test condition for no leaching is 260°C for 30 seconds. Typical examples of soldering processes that provide reliable joints without any damage are given in Fig 3.

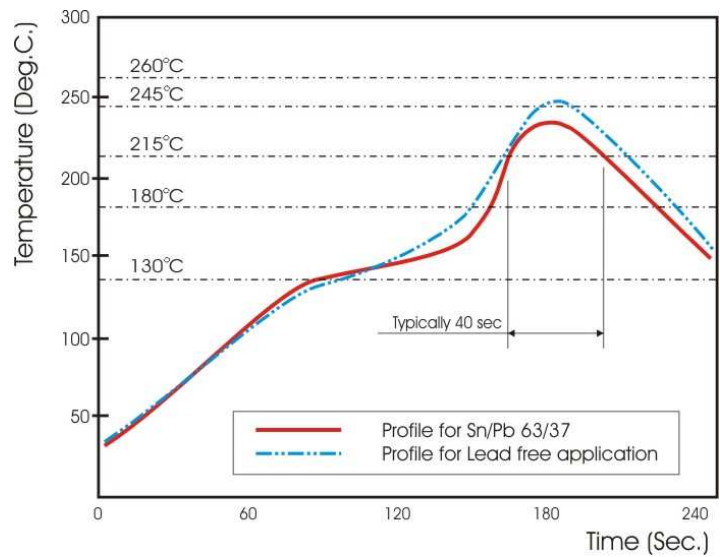

Fig 3. Infrared soldering profile

CATALOGUE NUMBERS

The resistors have a catalogue number starting with .

WW12	X	R020	J	T	L
Size code WW12 : 1206 WW08 : 0805 WW06 : 0603 WW04 : 0402	Type code X : Normal	Resistance code E96 +E24: R is first digit followed by 3 significant digits. 0.020Ω = R020 0.510Ω = R510 0.025Ω = R025	Tolerance J : ±5% G : ±2% F : ±1%	Packaging code T : 7" Reel taping	Termination code L = Sn base (lead free)

The resistors have a catalogue number starting with .

WW06	X	R100	J	T	L
Size code WW06 : 0603	Type code X : Normal	Resistance code E96 +E24: R is first digit followed by 2 significant digits. 0.200Ω = R20 0.510Ω = R51 0.499Ω = no marking	Tolerance J : ±5% G : ±2% F : ±1%	Packaging code T : 7" Reel taping	Termination code L = Sn base (lead free)

Tape packaging WW12,WW08,WW06 : 8mm width paper taping 5,000pcs per reel.

WW04: 8mm width paper taping 10,000pcs per reel.

TEST AND REQUIREMENTS(JIS C 5201-1 : 1998)

TEST	PROCEDURE	REQUIREMENT
Temperature Coefficient of Resistance(T.C.R) Clause 4.8	Natural resistance change per change in degree centigrade. $\frac{R_2 - R_1}{R_1(t_2 - t_1)} \times 10^6 \text{ (ppm/}^\circ\text{C)}$ $t_1 : 20^\circ\text{C}+5^\circ\text{C}-1^\circ\text{C}$ R ₁ : Resistance at reference temperature R ₂ : Resistance at test temperature	Refer to "QUICK REFERENCE DATA"
Short time overload (S.T.O.L) Clause 4.13	Permanent resistance change after a 5second application of a voltage 2.5 times RCWV or the maximum overload voltage specified in the above list, whichever is less.	ΔR/R max. ±(2%+0.005Ω) WW04X max ±(2%+0.010Ω)
Resistance to soldering heat(R.S.H) IEC 60068-2-58:2004	Un-mounted chips completely immersed for 10±1 second in a SAC solder bath at 255°C±5°C	no visible damage Δ R/R max. ±(1%+0.005Ω) WW04X max ±(1%+0.010Ω)
Solderability IEC 60068-2-58:2004	Un-mounted chips completely immersed for 3±0.3 second in a SAC solder bath at 245°C±5°C	good tinning (>95% covered) no visible damage
Temperature cycling Clause 4.19	30 minutes at -55°C±3°C, 2~3 minutes at 20°C+5°C-1°C, 30 minutes at +155°C±3°C, 2~3 minutes at 20°C+5°C-1°C, total 5 continuous cycles	no visible damage ΔR/R max. ±(1%+0.005Ω) WW04X max ±(1%+0.010Ω)
Load life (endurance) Clause 4.25	1000 +48/-0 hours, loaded with RCWV or Vmax in chamber controller 70±2°C, 1.5 hours on and 0.5 hours off	ΔR/R max. ±(3%+0.005Ω) WW04X max ±(5%+0.010Ω)
Load life in Humidity Clause 4.24	1000 +48/-0 hours, loaded with RCWV or Vmax in humidity chamber controller at 40°C±2°C and 90~95% relative humidity, 1.5hours on and 0.5 hours off	ΔR/R max. ±(3%+0.005Ω) WW04X max ±(5%+0.010Ω)
Bending strength Clause 4.33	Resistors mounted on a 90mm glass epoxy resin PCB(FR4); bending : 2 mm, once for 10 seconds	ΔR/R max. ±(1%+0.005Ω) WW04X max ±(1%+0.010Ω)
Adhesion Clause 4.32	Pressurizing force: 5N, Test time: 10±1sec.	No remarkable damage or removal of the terminations
Insulation Resistance JISC5201-1:1998 Clause 4.6	Apply the maximum overload voltage (DC) for 1minute	R ≥ 10GΩ
Dielectric Withstand Voltage JISC5201-1:1998 Clause 4.7	Apply the maximum overload voltage (AC) for 1 minute	No breakdown or flashover



PACKAGING

Paper Tape specifications (unit :mm)

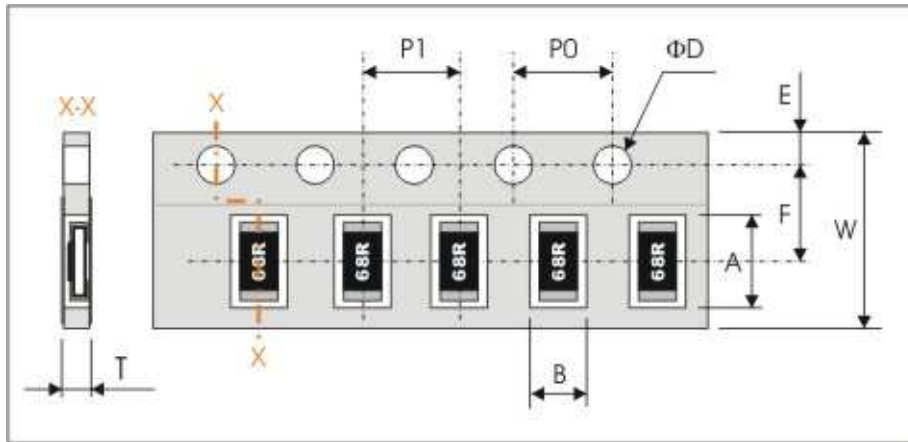

Series No.	A	B	W	F	E
WW12X	3.60±0.20	2.00±0.20	8.00±0.30	3.50±0.20	1.75±0.10
WW08X	2.40±0.20	1.65±0.20			
WW06X	1.90±0.20	1.10±0.20			
WW04X	1.20±0.10	0.70±0.10			

Series No.	P1	P0	ΦD	T
WW12X / WW08X	4.00±0.10	4.00±0.10	Φ1.50 ^{+0.1} _{-0.0}	Max. 1.0
WW06X				0.65±0.05
WW04X				0.40±0.05

Reel dimensions

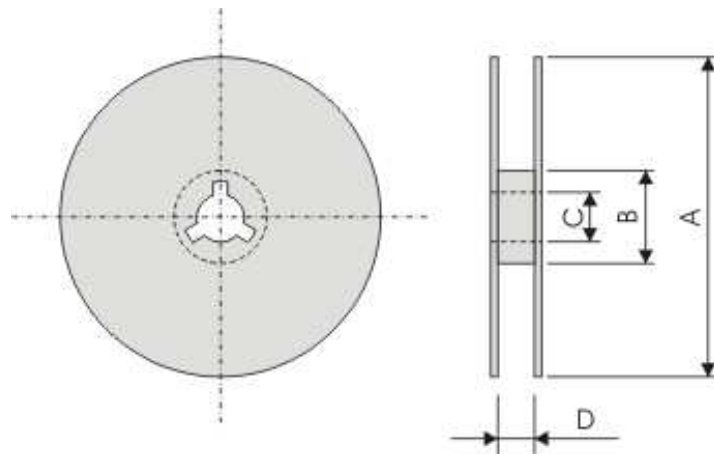

Symbol	A	B	C	D
(unit : mm)	Φ178.0±2.0	Φ60.0±1.0	13.0±0.2	9.0±0.5

Компания «Океан Электроники» предлагает заключение долгосрочных отношений при поставках импортных электронных компонентов на взаимовыгодных условиях!

Наши преимущества:

- Поставка оригинальных импортных электронных компонентов напрямую с производств Америки, Европы и Азии, а так же с крупнейших складов мира;
- Широкая линейка поставок активных и пассивных импортных электронных компонентов (более 30 млн. наименований);
- Поставка сложных, дефицитных, либо снятых с производства позиций;
- Оперативные сроки поставки под заказ (от 5 рабочих дней);
- Экспресс доставка в любую точку России;
- Помощь Конструкторского Отдела и консультации квалифицированных инженеров;
- Техническая поддержка проекта, помощь в подборе аналогов, поставка прототипов;
- Поставка электронных компонентов под контролем ВП;
- Система менеджмента качества сертифицирована по Международному стандарту ISO 9001;
- При необходимости вся продукция военного и аэрокосмического назначения проходит испытания и сертификацию в лаборатории (по согласованию с заказчиком);
- Поставка специализированных компонентов военного и аэрокосмического уровня качества (Xilinx, Altera, Analog Devices, Intersil, Interpoint, Microsemi, Actel, Aeroflex, Peregrine, VPT, Syfer, Eurofarad, Texas Instruments, MS Kennedy, Miteq, Cobham, E2V, MA-COM, Hittite, Mini-Circuits, General Dynamics и др.);

Компания «Океан Электроники» является официальным дистрибьютором и эксклюзивным представителем в России одного из крупнейших производителей разъемов военного и аэрокосмического назначения «JONHON», а так же официальным дистрибьютором и эксклюзивным представителем в России производителя высокотехнологичных и надежных решений для передачи СВЧ сигналов «FORSTAR».



JONHON

«JONHON» (основан в 1970 г.)

Разъемы специального, военного и аэрокосмического назначения:

(Применяются в военной, авиационной, аэрокосмической, морской, железнодорожной, горно- и нефтедобывающей отраслях промышленности)

«FORSTAR» (основан в 1998 г.)

ВЧ соединители, коаксиальные кабели, кабельные сборки и микроволновые компоненты:

(Применяются в телекоммуникациях гражданского и специального назначения, в средствах связи, РЛС, а так же военной, авиационной и аэрокосмической отраслях промышленности).



Телефон: 8 (812) 309-75-97 (многоканальный)

Факс: 8 (812) 320-03-32

Электронная почта: ocean@oceanchips.ru

Web: <http://oceanchips.ru/>

Адрес: 198099, г. Санкт-Петербург, ул. Калинина, д. 2, корп. 4, лит. А