



BIPOLAR ANALOG INTEGRATED CIRCUIT UPC2757TB / UPC2758TB

3 V, SUPER MINIMOLD SI MMIC DOWNCONVERTER

FEATURES

- **HIGH-DENSITY SURFACE MOUNTING:**
6 pin super minimold or SOT-363 package
- **WIDEBAND OPERATION:**
RF = 0.1 GHz to 2.0 GHz
IF = 20 MHz to 300 MHz
- **BUILT-IN POWER SAVE FUNCTION**
- **SUPPLY VOLTAGE:** $V_{CC} = 2.7$ TO 3.3 V

DESCRIPTION

The UPC2757TB and UPC2758TB are silicon RFICs manufactured using the NESAT™ III process. The devices consist of a mixer, an IF amplifier and an LO buffer amplifier. These devices are suitable as 1st IF downconverters for the receiver stage of cellular and other wireless systems. The UPC2757TB is designed for low power consumption while the UPC2758TB is designed for low distortion. The UPC2757TB/58TB are pin compatible and have comparable performance to the larger UPC2757T/58T, so they are suitable for use as a replacement to help reduce system size. The IC is housed in a 6 pin super minimold or SOT-363 package.

Stringent quality assurance and test procedures ensure the highest reliability and performance.

CONVERSION GAIN vs. LO FREQUENCY

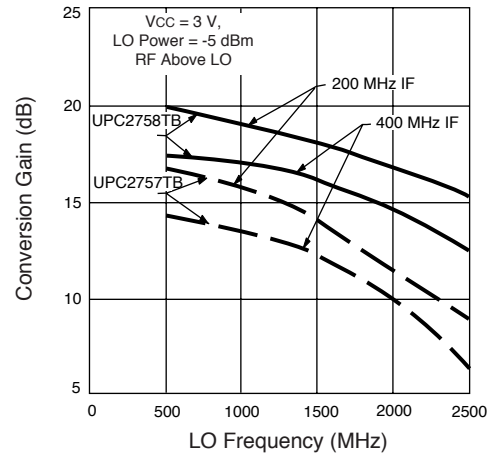

ELECTRICAL CHARACTERISTICS (TA = 25°C, VCC = VPS = 3.0 V, PLO = -10 dBm)

PART NUMBER PACKAGE OUTLINE			UPC2757TB S06			UPC2758TB S06		
SYMBOLS	PARAMETERS AND CONDITIONS	UNITS	MIN	TYP	MAX	MIN	TYP	MAX
ICC	Circuit Current, $V_{PS} = 3$ V $V_{PS} = 0.5$ V	mA μ A	3.7	5.6 0.1	7.7	6.6	11 0.1	14.8
fRF	RF Operating Frequency Range (The conversion gain at fRF is not more than 3 dB down from the gain at fRF = 800 MHz, fIF = 130 MHz)	GHz	0.1		2.0	0.1		2.0
fIF	IF Operating Frequency Range (The conversion gain at fIF is not more than 3 dB down from the gain at fRF = 800 MHz, fIF = 130 MHz)	MHz	20		300	20		300
CG	Conversion Gain ¹ , fRF = 800 MHz, fIF = 130 MHz fRF = 2.0 GHz, fIF = 250 MHz	dB	12	15	18	16	19	22
		dB	10	13	16	14	17	20
NF	Noise Figure, SSB fRF = 800 MHz, fIF = 130 MHz fRF = 2.0 GHz, fIF = 250 MHz	dB		10	13		9	12
		dB		13	16		13	15
PSAT	Saturated Output Power ² , fRF = 800 MHz, fIF = 100 MHz fRF = 2.0 GHz, fIF = 250 MHz	dBm	-11	-3		-7	+1	
		dBm	-11	-8		-7	-4	
P1dB	Output Power at 1dB compression point fRF = 800 MHz fIF = 100 MHz	dBm		-8			-3.5	
OIP3	Output 3rd Order Intercept Point, (SSB) PLO = -10 dBm fRF = 0.8~2.0 GHz, fIF = 100 MHz	dBm		+5			+11	
ISOL	LO Leakage, fLO = 0.8 ~2.0 GHz	at RF pin		-35			-30	
		at IF pin		-23			-15	
RTH (J-A)	Thermal Resistance (Junction to Ambient) Mounted on a 50 x 50 x 1.6 mm epoxy glass PWB	°C/W			325			325

Notes:

1. PRF = -40 dBm.
2. PRF = -10 dBm.

UPC2757TB, UPC2758TB

ABSOLUTE MAXIMUM RATINGS¹ (T_A = 25°C)

SYMBOLS	PARAMETERS	UNITS	RATINGS
V _{CC} , V _{PS}	Supply Voltage	V	5.5
P _T	Total Power Dissipation ²	mW	200
T _{OP}	Operating Temperature	°C	-40 to +85
T _{STG}	Storage Temperature	°C	-55 to +150

Notes:

- Operation in excess of any one of these parameters may result in permanent damage.
- Mounted on a 50 x 50 x 1.6 mm epoxy glass PWB (T_A = +85°C).

RECOMMENDED OPERATING CONDITIONS

SYMBOLS	PARAMETERS	UNITS	MIN	TYP	MAX
V _{CC}	Supply Voltage	V	2.7	3.0	3.3
T _{OP}	Operating Temperature	°C	-40	+25	+85
P _{LO}	LO Input Level	dBm	-15	-10	0

TEST CIRCUIT/BLOCK DIAGRAM

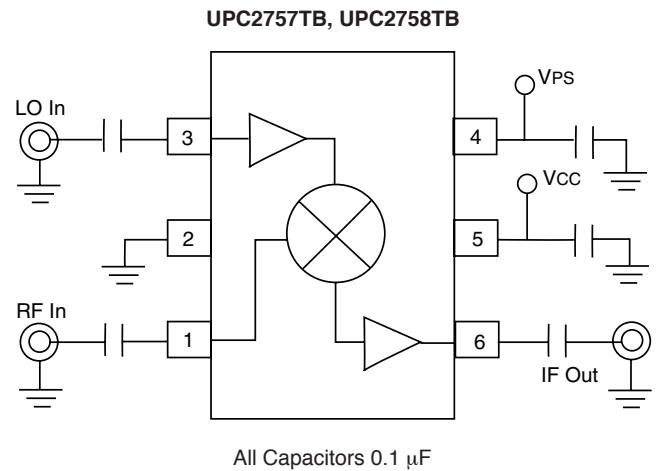

PIN DESCRIPTION

Pin No.	Pin Name	Applied Voltage (V)	Pin Voltage (V)	Description	Internal Equivalent Circuit						
1	RFIN	—	1.2	Signal input pin to double balanced mixer. This pin must be coupled to the signal source with a blocking capacitor.							
2	GND	0	—	Ground pin. This pin should be connected to system ground with minimum inductance. Ground pattern on the board should be formed as wide as possible.							
3	LOIN	—	1.3	LO input pin. The LO buffer is designed as a differential amplifier. Recommended input level is -15 to 0 dBm.							
4	VPS	VCC / GND	—	Power save control pin can control the On/Sleep state with bias as follows: <table border="1" style="margin-left: auto; margin-right: auto;"> <thead> <tr> <th>V_{PS} (V)</th> <th>STATE</th> </tr> </thead> <tbody> <tr> <td>≥2.5</td> <td>ON</td> </tr> <tr> <td>0 to 0.5</td> <td>SLEEP</td> </tr> </tbody> </table> Rise time/fall time using this pin is approximately 10 μs.	V _{PS} (V)	STATE	≥2.5	ON	0 to 0.5	SLEEP	
V _{PS} (V)	STATE										
≥2.5	ON										
0 to 0.5	SLEEP										
5	VCC	2.7 to 3.3	—	Power supply pin. This pin should be externally equipped with a bypass capacitor to minimize ground impedance.							
6	IFOUT	—	1.7	Output of single-ended push-pull IF buffer amplifier. This is an emitter-follower output with low impedance. This pin must be coupled to the next stage with a blocking capacitor.							

TYPICAL PERFORMANCE CURVES (TA = 25°C)

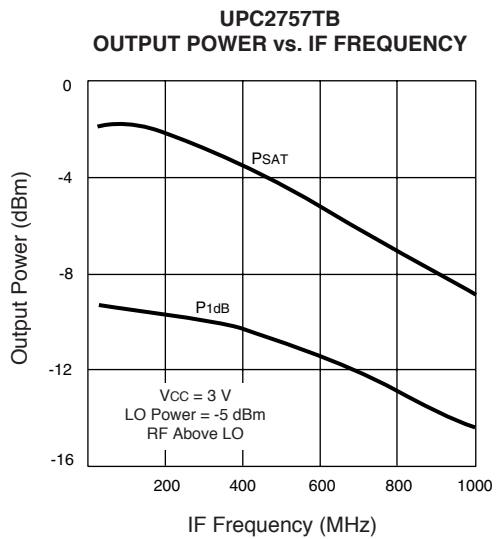
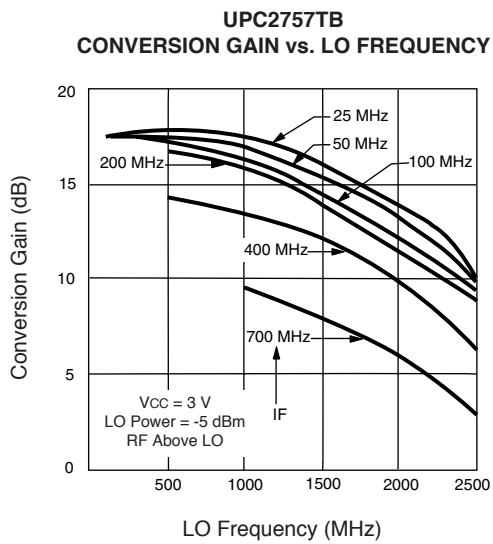
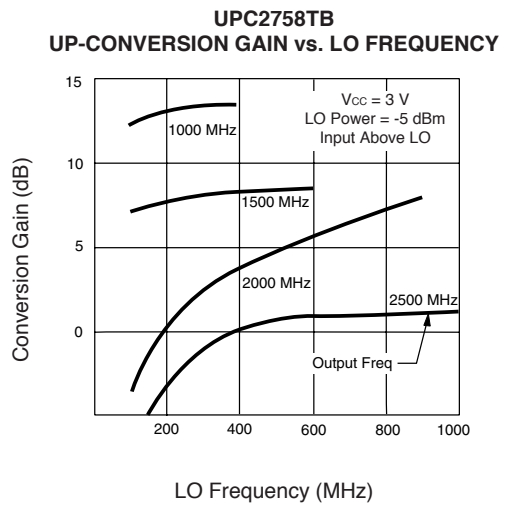
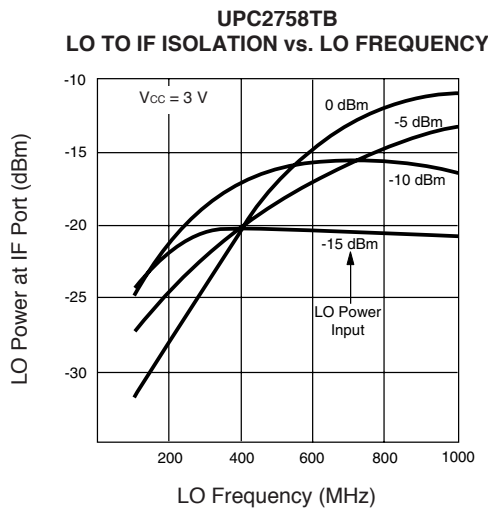
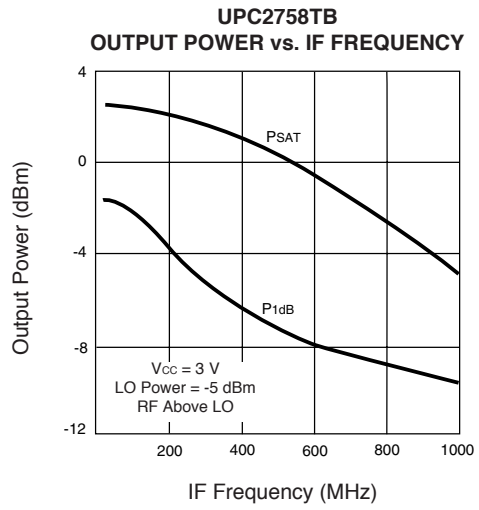
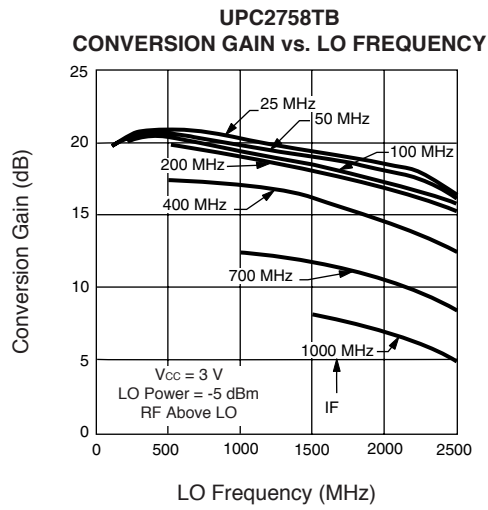

TYPICAL PERFORMANCE CURVES (T_A = 25°C)

UPC2757TB
LO TO IF ISOLATION vs. LO FREQUENCY

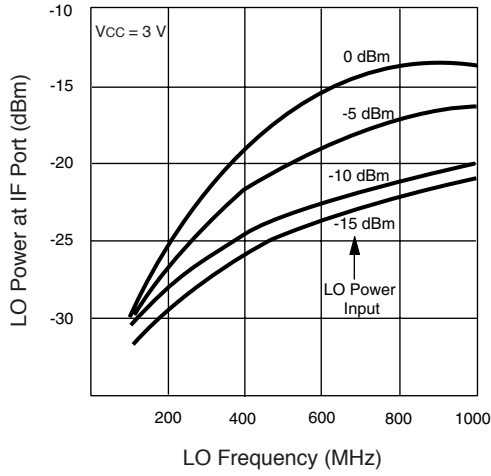

UPC2757TB
UP-CONVERSION GAIN vs. LO FREQUENCY

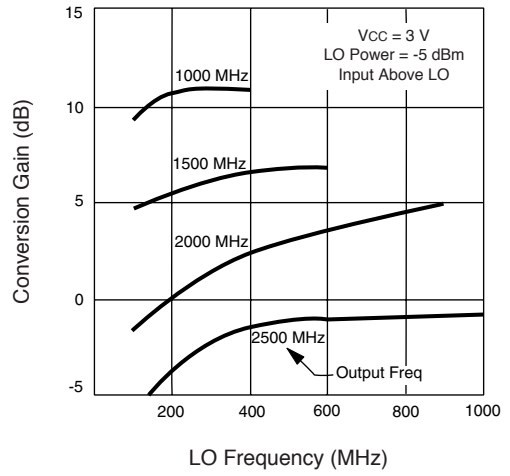

UPC2757TB
CONVERSION GAIN vs. LO FREQUENCY

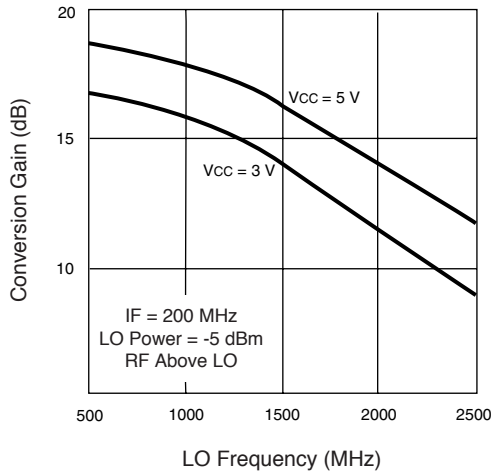

UPC2757TB
CONVERSION GAIN vs. LO POWER

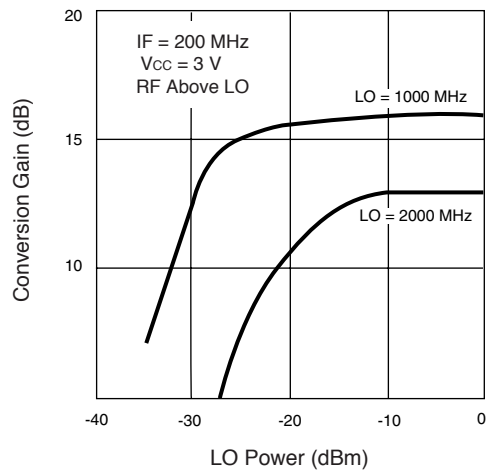

APPLICATION EXAMPLE

Digital Cellular Telephone

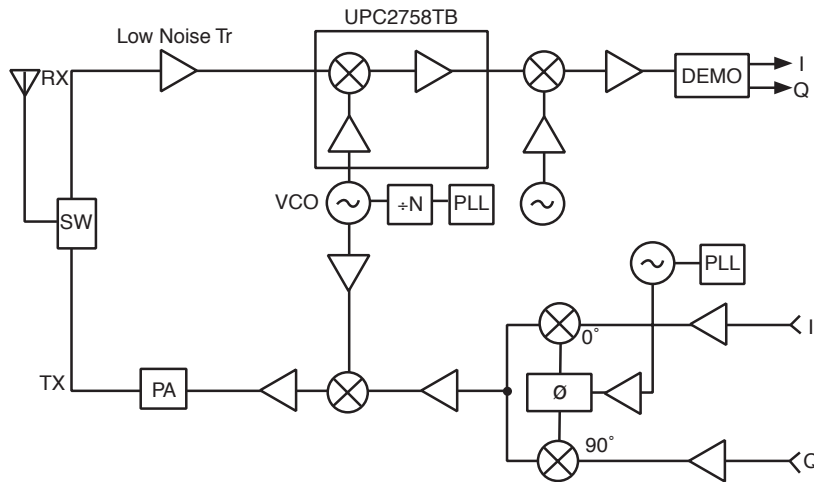

ORDERING INFORMATION

PART NUMBER	QTY
UPC2757TB-E3-A	3K/Reel
UPC2758TB-E3-A	3K/Reel

Note:
Embossed Tape, 8 mm wide,
Pins 1, 2, 3 are in tape pull-out direction.

OUTLINE DIMENSIONS

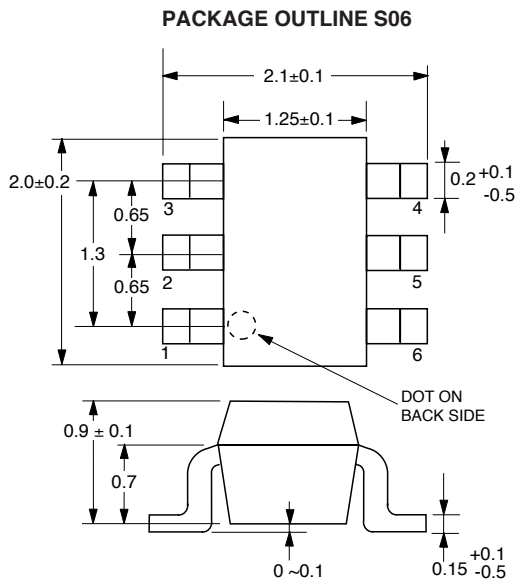

Note:
All dimensions are typical unless otherwise specified.

INTERNAL BLOCK DIAGRAM

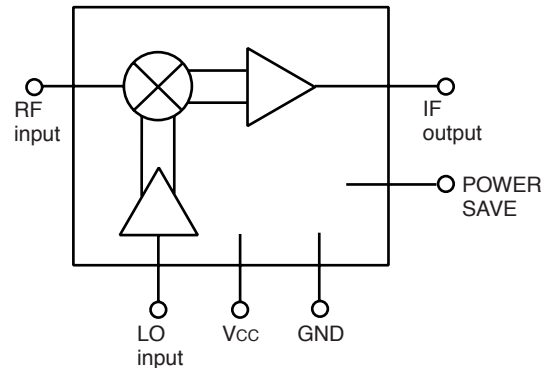

LEAD CONNECTIONS

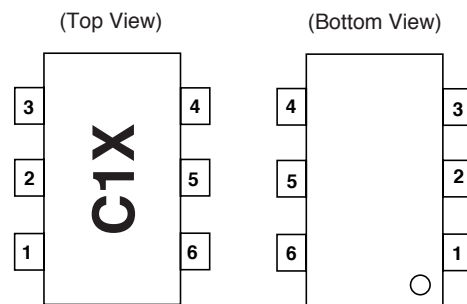

1. RF INPUT
2. GND
3. LO INPUT
4. PS
5. Vcc
6. IF OUTPUT

Note:
Package Markings:
C1X: UPC2757TB
C1Y: UPC2758TB

EXCLUSIVE NORTH AMERICAN AGENT FOR RF, MICROWAVE & OPTOELECTRONIC SEMICONDUCTORS

CEL CALIFORNIA EASTERN LABORATORIES • Headquarters • 4590 Patrick Henry Drive • Santa Clara, CA 95054-1817 • (408) 988-3500 • Telex 34-6393 • FAX (408) 988-0279
DATA SUBJECT TO CHANGE WITHOUT NOTICE

Internet: <http://WWW.CEL.COM>

10/24/2001

Компания «Океан Электроники» предлагает заключение долгосрочных отношений при поставках импортных электронных компонентов на взаимовыгодных условиях!

Наши преимущества:

- Поставка оригинальных импортных электронных компонентов напрямую с производств Америки, Европы и Азии, а так же с крупнейших складов мира;
- Широкая линейка поставок активных и пассивных импортных электронных компонентов (более 30 млн. наименований);
- Поставка сложных, дефицитных, либо снятых с производства позиций;
- Оперативные сроки поставки под заказ (от 5 рабочих дней);
- Экспресс доставка в любую точку России;
- Помощь Конструкторского Отдела и консультации квалифицированных инженеров;
- Техническая поддержка проекта, помощь в подборе аналогов, поставка прототипов;
- Поставка электронных компонентов под контролем ВП;
- Система менеджмента качества сертифицирована по Международному стандарту ISO 9001;
- При необходимости вся продукция военного и аэрокосмического назначения проходит испытания и сертификацию в лаборатории (по согласованию с заказчиком);
- Поставка специализированных компонентов военного и аэрокосмического уровня качества (Xilinx, Altera, Analog Devices, Intersil, Interpoint, Microsemi, Actel, Aeroflex, Peregrine, VPT, Syfer, Eurofarad, Texas Instruments, MS Kennedy, Miteq, Cobham, E2V, MA-COM, Hittite, Mini-Circuits, General Dynamics и др.);

Компания «Океан Электроники» является официальным дистрибьютором и эксклюзивным представителем в России одного из крупнейших производителей разъемов военного и аэрокосмического назначения «JONHON», а так же официальным дистрибьютором и эксклюзивным представителем в России производителя высокотехнологичных и надежных решений для передачи СВЧ сигналов «FORSTAR».



JONHON

«JONHON» (основан в 1970 г.)

Разъемы специального, военного и аэрокосмического назначения:

(Применяются в военной, авиационной, аэрокосмической, морской, железнодорожной, горно- и нефтедобывающей отраслях промышленности)

«FORSTAR» (основан в 1998 г.)

ВЧ соединители, коаксиальные кабели, кабельные сборки и микроволновые компоненты:

(Применяются в телекоммуникациях гражданского и специального назначения, в средствах связи, РЛС, а так же военной, авиационной и аэрокосмической отраслях промышленности).



Телефон: 8 (812) 309-75-97 (многоканальный)

Факс: 8 (812) 320-03-32

Электронная почта: ocean@oceanchips.ru

Web: <http://oceanchips.ru/>

Адрес: 198099, г. Санкт-Петербург, ул. Калинина, д. 2, корп. 4, лит. А