

## DESCRIPTION

Demonstration Circuit DC688 is a quad output power supply intended for use in small to medium size TFT panels. The circuit features the LT1942 quad output switching regulator and generates an LED driver along with the triple output supply required for the TFT panels. With an input voltage range of 3V to 4.2V, two step-up regulators and one inverting regulator provide  $AV_{DD}$ ,  $V_{ON}$  and  $V_{OFF}$  bias voltages for the LCD panels. Another high power boost is used to drive 12 LEDs (2 strings of 6 each). For 3V minimum input voltage, up to 20mA current is available for each LED string. A built-in LED ballast circuit is included to precisely match the LED currents in the two strings. The LED driver has a precise

dimming control. A voltage between 0.25V to 2.5V can be applied to CTRL4 pin to control the dimming level.

An internal high side PNP provides delayed turn on of the  $V_{ON}$  signal for panel protection. A P-channel MOSFET driven by the output of PGOOD pin is added at the output of  $AV_{DD}$  to provide output disconnect in shutdown.

All four switchers are synchronized to the internal 1MHz clock, allowing the use of low profile inductors and ceramic capacitors. Both the  $AV_{DD}$  boost converter and the LED driver have soft-start to limit inrush current.

**Design files for this circuit board are available. Call the LTC factory.**

**Table 1. Performance Summary**

PARAMETER	CONDITION	VALUE
Output Voltage $AV_{DD}$	$V_{IN} = 3V$ to 4.5V, $I_{OUT} = 0mA$ to 40mA	$5V \pm 4\%$
Maximum Output Current at $AV_{DD}$	$V_{IN} = 3V$ to 4.5V (Note 1)	40mA
Current at LED1 or LED2	$V_{IN} = 3V$ to 4.5V, $R7=4.99\Omega$	$20mA \pm 6\%$
Typical Output Ripple $AV_{DD}$	$V_{IN} = 4V$ , load at $AV_{DD} = 40mA$ (20MHz BW)	$8mV_{P-P}$
Typical Switching Frequency		1MHz
SHDN Control	Logic Low Voltage-Off, $T_A = 25^\circ C$	0.4V MAX
	Logic High Voltage-On, $T_A = 25^\circ C$	1.0V MIN

**Note 1: The  $AV_{DD}$  output can supply more current with a larger inductor. For example, it can deliver 50mA load current with Sumida CLS4D14-330 (33 $\mu$ H).**

## QUICK START PROCEDURE

Demonstration circuit 688 is easy to set up to evaluate the performance of the LT1942. Refer to Figure 1 for proper measurement equipment setup and follow the procedure below:

**When measuring the input or output voltage ripple, care must be taken to avoid a long ground lead on the oscilloscope probe. Measure the input or output voltage ripple by touching the probe tip directly across the input or one of the outputs and GND terminals. See Figure 2 for proper scope probe technique.**

1. With power off, connect the input power supply to Vin and GND.
2. Place JP1 in RUN position; JP2 in ON position.
3. Set the input voltage between 3V to 4.5V. Turn on the power at the input.
4. Check for the proper output voltages. If any output voltage is lower than the set value, temporarily disconnect the load to make sure that the load is not set too high.

# QUICK START GUIDE FOR DEMONSTRATION CIRCUIT 688

## QUAD OUTPUT SWITCHING REGULATORS FOR TFT SUPPLY AND LED DRIVER

- Once the proper output voltages are established, adjust the loads within the operating range and observe the output voltage regulation, ripple voltage, efficiency and other parameters.
- The LED driver can be turned off independently by putting JP2 in off position. LED dimming (2.5mA to

20mA each string) can be easily achieved by applying a voltage between 0.1V to 2.5V at CTRL4 pin. Refer to datasheet for more information.

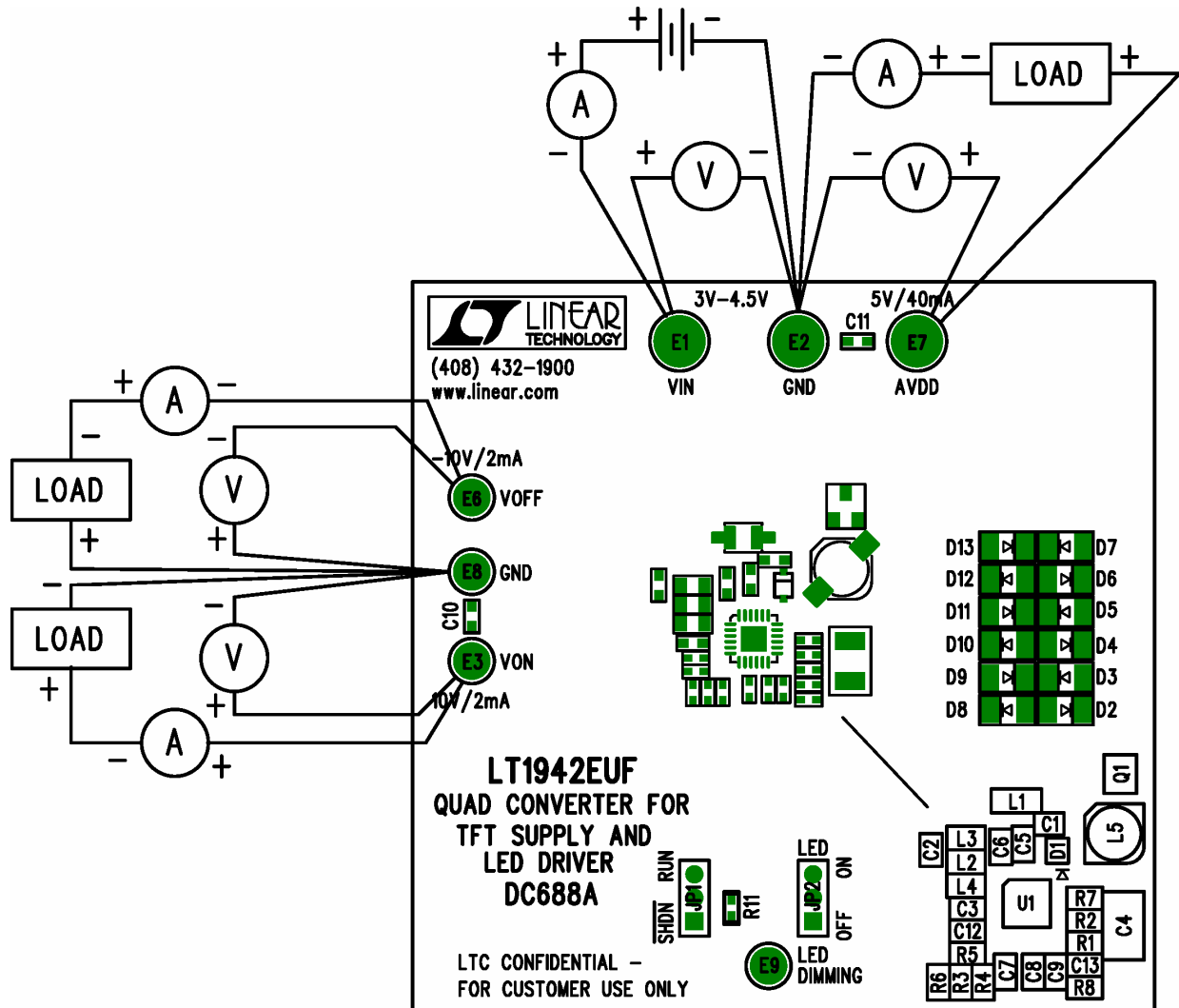

Figure 1. Proper Measurement Equipment Setup

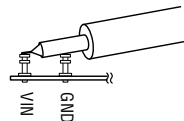

Figure 2. Measuring Input or Output Ripple

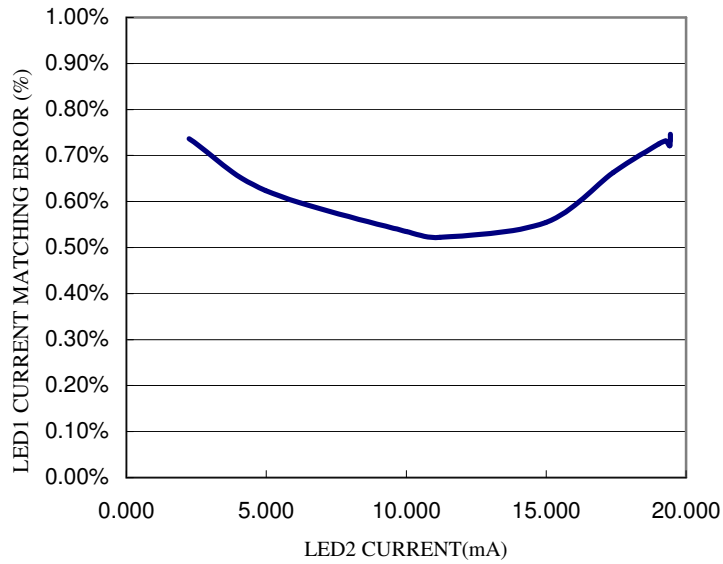
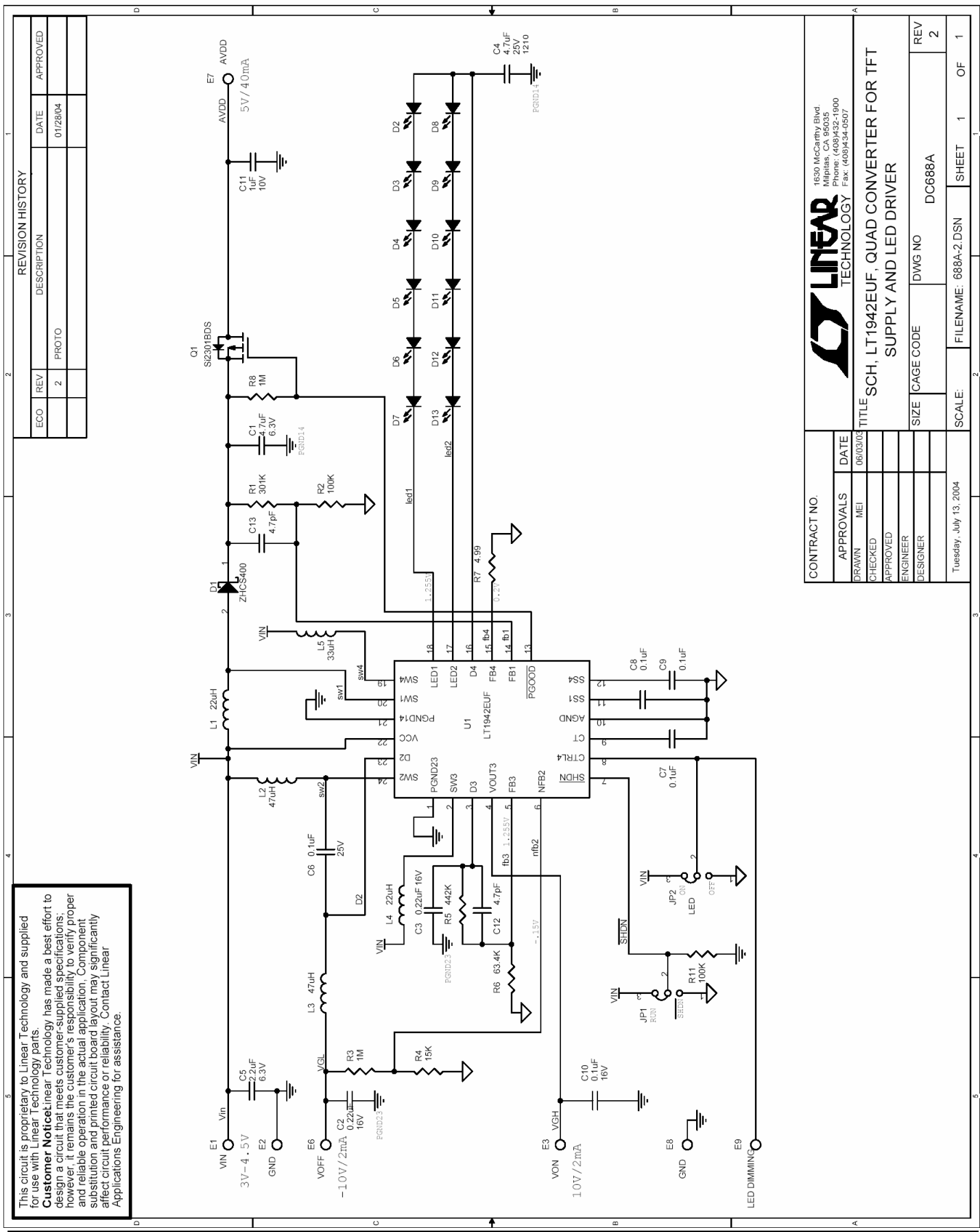

Figure 3. Typical current matching between LED1 and LED2

# QUICK START GUIDE FOR DEMONSTRATION CIRCUIT 688

## QUAD OUTPUT SWITCHING REGULATORS FOR TFT SUPPLY AND LED DRIVER



This circuit is proprietary to Linear Technology and supplied for use with Linear Technology parts.  
**Customer Notice:** Linear Technology has made a best effort to design a circuit that meets customer-supplied specifications; however, it remains the customer's responsibility to verify proper and reliable operation in the actual application. Component substitution and printed circuit board layout may significantly affect circuit performance or reliability. Contact Linear Applications Engineering for assistance.

REVISION HISTORY				
ECO	REV	DESCRIPTION	DATE	APPROVED
	2	PROTO	01/28/04	

CONTRACT NO.		DATE	
APPROVALS	MEI	06/03/03	
CHECKED			
APPROVED			
ENGINEER			
DESIGNER			
Tuesday, July 13, 2004		SCALE:	
FILENAME: 688A-2.DSN		SHEET 1 OF 1	

**LINEAR TECHNOLOGY**  
 1650 McCarthy Blvd.  
 Milpitas, CA 95035  
 Phone: (408)432-1900  
 Fax: (408)434-0507

**TITLE** SCH, LT1942EUF, QUAD CONVERTER FOR TFT SUPPLY AND LED DRIVER

**SIZE** ICAGE CODE DWG NO DC688A **REV** 2



Компания «Океан Электроники» предлагает заключение долгосрочных отношений при поставках импортных электронных компонентов на взаимовыгодных условиях!

Наши преимущества:

- Поставка оригинальных импортных электронных компонентов напрямую с производств Америки, Европы и Азии, а так же с крупнейших складов мира;
- Широкая линейка поставок активных и пассивных импортных электронных компонентов (более 30 млн. наименований);
- Поставка сложных, дефицитных, либо снятых с производства позиций;
- Оперативные сроки поставки под заказ (от 5 рабочих дней);
- Экспресс доставка в любую точку России;
- Помощь Конструкторского Отдела и консультации квалифицированных инженеров;
- Техническая поддержка проекта, помощь в подборе аналогов, поставка прототипов;
- Поставка электронных компонентов под контролем ВП;
- Система менеджмента качества сертифицирована по Международному стандарту ISO 9001;
- При необходимости вся продукция военного и аэрокосмического назначения проходит испытания и сертификацию в лаборатории (по согласованию с заказчиком);
- Поставка специализированных компонентов военного и аэрокосмического уровня качества (Xilinx, Altera, Analog Devices, Intersil, Interpoint, Microsemi, Actel, Aeroflex, Peregrine, VPT, Syfer, Eurofarad, Texas Instruments, MS Kennedy, Miteq, Cobham, E2V, MA-COM, Hittite, Mini-Circuits, General Dynamics и др.);

Компания «Океан Электроники» является официальным дистрибьютором и эксклюзивным представителем в России одного из крупнейших производителей разъемов военного и аэрокосмического назначения «JONHON», а так же официальным дистрибьютором и эксклюзивным представителем в России производителя высокотехнологичных и надежных решений для передачи СВЧ сигналов «FORSTAR».



## JONHON

«JONHON» (основан в 1970 г.)

Разъемы специального, военного и аэрокосмического назначения:

(Применяются в военной, авиационной, аэрокосмической, морской, железнодорожной, горно- и нефтедобывающей отраслях промышленности)

«FORSTAR» (основан в 1998 г.)

ВЧ соединители, коаксиальные кабели,  
кабельные сборки и микроволновые компоненты:

(Применяются в телекоммуникациях гражданского и специального назначения, в средствах связи, РЛС, а так же военной, авиационной и аэрокосмической отраслях промышленности).



Телефон: 8 (812) 309-75-97 (многоканальный)

Факс: 8 (812) 320-03-32

Электронная почта: [ocean@oceanchips.ru](mailto:ocean@oceanchips.ru)

Web: <http://oceanchips.ru/>

Адрес: 198099, г. Санкт-Петербург, ул. Калинина, д. 2, корп. 4, лит. А