

# NCP1031POEEVB

## NCP1031 6.5 W POE DC-DC Converter Evaluation Board User's Manual



ON Semiconductor®

<http://onsemi.com>

### EVAl BOARD USER'S MANUAL

#### Introduction

A solution to one aspect of Power Over Ethernet (POE) is presented here utilizing the ON Semiconductor NCP1031 series of monolithic, high voltage switching regulators with internal MOSFET. The evaluation board user's manual provides details for constructing an inexpensive, high efficiency, 5.0 V DC power supply with a power output of 5.0 to 6.5 W, (output power is conversion mode dependent – see DC to DC Converter Operation description below). The associated input circuitry for responding to POE detection and classification protocol is also included. ON Semiconductor also can provide a demonstration PC board with this circuitry upon request.

#### POE Background

As a result of IEEE Standard 802.3AF, it is now possible to inject DC power through Ethernet data transmission lines to power Ethernet communication devices as long as the end power requirement is less than 13 W. The parametric details of DC power transmission and the associated terminology is outlined in this IEEE document. POE consists of two power entities: Power Sourcing Equipment (PSE) and Powered Devices (PDs). The PSEs typically provides 48 Vdc nominal to the LAN cables while the PDs are small DC-DC

converters at the load end of the cables which transform the 48 V to logic levels such as 5.0 Vdc or 3.3 Vdc or both, to power the communications equipment. The PDs should be able to operate with a maximum average input power of 12.95 W, and should be able to tolerate an input voltage range of 36 to 57 Vdc. In addition, a certain "protocol" is required in which the PD is detected (Signature Mode) and then classified (Classification Mode) according to its maximum power level.

#### Signature Detection:

The upstream PSE equipment detects the PD by injecting two different voltages between 2.8 and 10 Vdc into the PD input terminals. If the detected impedance of the PD as measured by the V/I slope is above 23.7 k $\Omega$ , and below 26.25 k $\Omega$ , the PD is considered present. If the impedance is less than 15 k, or greater than 33 k, the PD is considered not present, and no further voltage will be applied.

#### Classification Mode:

To classify the PD according to its intended power level, the PSE will again source a voltage between 14.5 and 20.5 Vdc to the PD. The classification is determined by the current drawn by the PD upon application of this voltage, and is summarized in the Table 1.

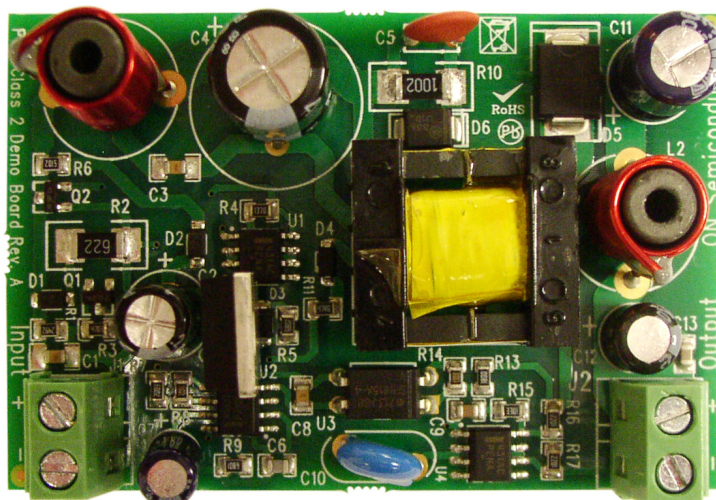

Figure 1. NCP1031 Evaluation Board

# NCP1031POEEVB

**Table 1. CLASSIFICATION**

Class	P <sub>min</sub>	P <sub>max</sub>	I <sub>class min</sub> *	I <sub>class max</sub> *	R <sub>class (R4)</sub> *
0	0.44 W	12.95 W	0 mA	4.0 mA	Open
1	0.44 W	3.84 W	9.0 mA	12 mA	217 Ω
2	3.84 W	6.49 W	17 mA	20 mA	135 Ω
3	6.49 W	12.95 W	26 mA	30 mA	91 Ω
4	TBD	TBD	36 mA	44 mA	62 Ω

\*Note that from the 4<sup>th</sup> and 5<sup>th</sup> columns on the table, that the current drawn from the PSE falls between the I<sub>class</sub> minimum and maximum values for a given power classification. The last column is the value of the resistor (R4) required for classification in the circuit described by this evaluation board user's manual.

## Additional Input Features

In addition to the signature and classification circuitry, the PD must also include circuitry to limit the inrush current from the PSE to 400 mA when the input voltage is applied, and to prevent any quiescent currents or impedances caused by the DC-to-DC converter to be ignored during the signature and classification processes.

## Signature/Classification Circuit Details

Referring to the schematic of Figure 3, the input signature and classification circuitry is designed around a few discrete and inexpensive ON Semiconductor parts that include the TL431 programmable reference, a 2N7002 signal level MOSFET, a 2N5550 NPN transistor, an NTD12N10 MOSFET and several Zener diodes and a few resistors and capacitors. For signature detection, a 24.9 K resistor (R1) is placed directly across the input. Note that during signature detection, the input voltage is below 10 V and the constant current source formed by U1, Q2 and R4 is off because of the 9.1 V Zener that must be overcome to bias this circuit. Note also that MOSFET Q3, which functions as a series input switch in the return leg of the DC-DC converter, will be off until the input voltage exceeds approximately 27 V. This voltage is the sum of D2's Zener voltage and the gate threshold of Q3.

As the voltage is ramped up to the classification level, D1 conducts above approximately 9.8 V and the current source formed by U1, Q2 and resistor R4 turns on and the current is precisely limited by the reference voltage of U1 (2.5 V) and the classification resistor R4.

Once classification is verified the input can now ramp up to the nominal 48 V. Once this voltage exceeds the sum of Q3's gate threshold and D2's Zener voltage, Q3 will start to turn on. It will not turn on abruptly, however, but will operate in its linear region momentarily due to the RC time constant created by R6 and C2. The momentary operation in the linear region allows for inrush current limiting because Q3 will act like a resistor during this period. D3 clamps the voltage on Q3's gate to 15 V, while R5 provides a discharge path for C2 when the input from the PSE is off. MOSFET Q1 will also turn on at the same voltage level as Q3, and this will switch off the U1/Q2 current source so as to reduce additional current drain from the input.

## DC to DC Converter Operation

The DC-to-DC converter is designed around ON Semiconductor's monolithic NCP1031 switching regulator IC (U2). For a 5.0 W maximum output, the converter is configured as a discontinuous mode (DCM) flyback topology with the conventional TL431 and optocoupler voltage feedback scheme. Modifications to the transformer design and the control loop compensation network for continuous conduction mode flyback operation will allow up to 6.5 W (1.3 A) output. The input utilizes a differential mode pi filter comprised of C3, L1 and C4. Control chip startup is accomplished when the undervoltage terminal at pin 6 exceeds 2.5 V. The resistor divider network of R7, R8, and R9 sets the chip's under and overvoltage levels to 35 and 80 V, respectively. Internal startup bias is provided thru pin 8, which drives a constant current source that charges V<sub>CC</sub> capacitor C7. Once U2 has started, the auxiliary winding on transformer T1 (pins 2, 3) provides the operating bias via diode D4 and resistor R11.

Voltage spikes caused by the leakage inductance of T1 are clamped by the network of C5, D6 and R10. The actual power rating on R10 will be a function of the primary-to-secondary leakage inductance of T1, and the lower the better. Capacitor C6 sets the switching frequency of the converter to approximately 220 kHz.

Because of the required secondary isolation, a TL431 (U4) is implemented as an error amplifier along with optocoupler U3 to create the voltage sensing and feedback circuitry. The internal error amplifier in U2 has been disabled by grounding pin 3, the voltage sense pin, and the amplifier's output compensation node on pin 4 is utilized to control the pulse width via the optocoupler's photo transistor. The output voltage sense is divided down to the 2.5 V reference level of the TL431 by R16 and R17, and closed loop bandwidth and phase margins are set by C9 and R15 for DCM operation. Additional components C14, C15 and R12 are required for feedback loop stabilization if configured for CCM flyback operation. C8 on the primary side provides noise decoupling and additional high frequency roll off for U2. This implementation provides output regulation better than 0.5% for both line and load changes, and a closed loop phase margin of better than 50°.

## NCP1031POEEVB

Output rectifier D5 is a three amp Schottky device for enhanced efficiency, and the output voltage is filtered by the pi network comprised of C11, L2 and C12. Typical peak-to-peak noise and ripple on the output are below 100 mV under all normal load and line conditions. C13 provides for additional high frequency noise attenuation. Typical input to output efficiency is in the area of 75% at full load. Higher efficiencies can be achieved by replacing D5 with a MOSFET based synchronous rectifier circuit (see ON Semiconductor evaluation board user's manual, EVBUM2132/D, for implementing a simple synchronous rectifier circuit to a flyback topology).

Overcurrent protection is provided by the internal peak current limit circuit in the NCP1031. The circuit can provide a continuous output current of 1.3 A at 25°C with surge up to 1.5 A when configured as a CCM flyback before overcurrent and/or overtemperature limiting ensues. When configured for the discontinuous mode, the current is limited to about 1.0 A with a 1.2 A peak.

### Magnetics Design

The discontinuous mode flyback transformer design is detailed in Figure 4 and the continuous mode transformer is shown in Figure 5. In the design of flyback transformers, it is essential to keep the windings in single layers and evenly spread over the window length of the core structure to keep leakage inductance minimized. In this application, this was easily achieved, with a small EF16 ferrite core from Ferroxcube.

### Discontinuous Versus Continuous Mode Operation

In discontinuous mode flyback operation, the inductor current falls to zero before the MOSFET switch is turned on again. This mode of operation causes the output to have a first order filter network characteristic and, as a consequence, feedback loop stabilization is simple and wide bandwidth for good output transient response can be achieved. This operational mode, unfortunately results in higher peak switch currents and limits the power output of this circuit due to the internal current limit set point and the thermal protection circuits in the NCP1031. With continuous current mode operation, where the MOSFET can

turn back on before the inductor current is zero, the peak switch current is less, so higher power outputs can be achieved without overcurrent protection intervention. There is a cost, however, to this latter mode of operation in that the control loop bandwidth must be made lower with a resulting poorer transient response to load and line variation. CCM operation introduces a right half-plane zero to the power topology response characteristic which may need to be compensated for with the additional feedback components shown in Figure 3, if proper feedback stability is to be achieved. CCM may also generate more EMI due to the fact that the output rectifier must now be force commutated off.

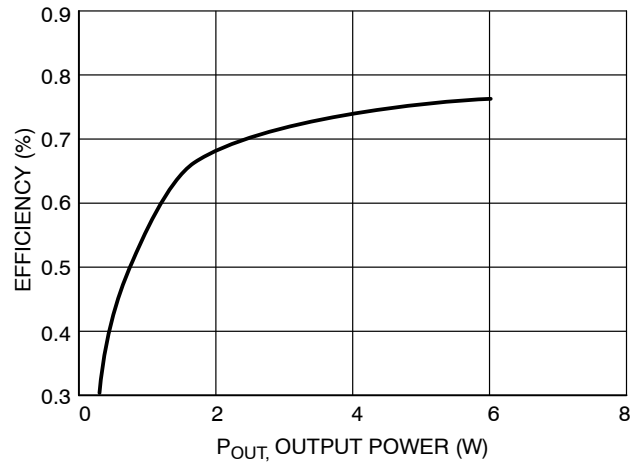

Figure 2. Efficiency Versus Output Power Graph

### References

1. IEEE Standard 802.3AF (Ethernet power transmission standards).
2. Power Electronic Technology Magazine, June 2004, Page 45.
3. ON Semiconductor Data Sheet – NCP1030, NCP1031.
4. On Semiconductor Application Note AND8119, “Design of an Isolated 2.0 W Bias Supply for Telecom Systems Using the NCP1030”.



# NCP1031POEEVB

Part Description: 5 W, 200 kHz POE Flyback Transform, 5 V<sub>OUT</sub>, 48 V<sub>IN</sub>

Schematic ID: T1

Core Type: Ferroxcube EF16 (E16/8/5); 3C95 Material Or Similar

Core Gap: Gap for 100 μH

Inductance: 90 – 100 μH

Bobbin Type: 8 Pin Horizontal Mount for EF16

**Windings (in order):**

Winding # / Type	Turns / Material / Gauge / Insulation Data
V <sub>CC</sub> / BOOST(2 – 3)	9 turns of #28HN spiral wound over 1 layer. Insulate with 1 layer of tape (250 V insulation to next winding).
Primary(1 – 4)	24 turns of #28HN over 1 layer. Insulate for 1.5 kV to the next winding.
5 V Secondary (5, 6 – 7, 8)	4 turns of 4 strands of #28HN flat wound over 1 layer evenly and terminated with 2 strands per pin. Insulate with tape.

NOTE: Vendor for this transform is Mesa Power Systems (Escondido, CA). Part# 131297.

Hipot: 1.5 kV from V<sub>CC</sub> Boost/Primary to Secondary.

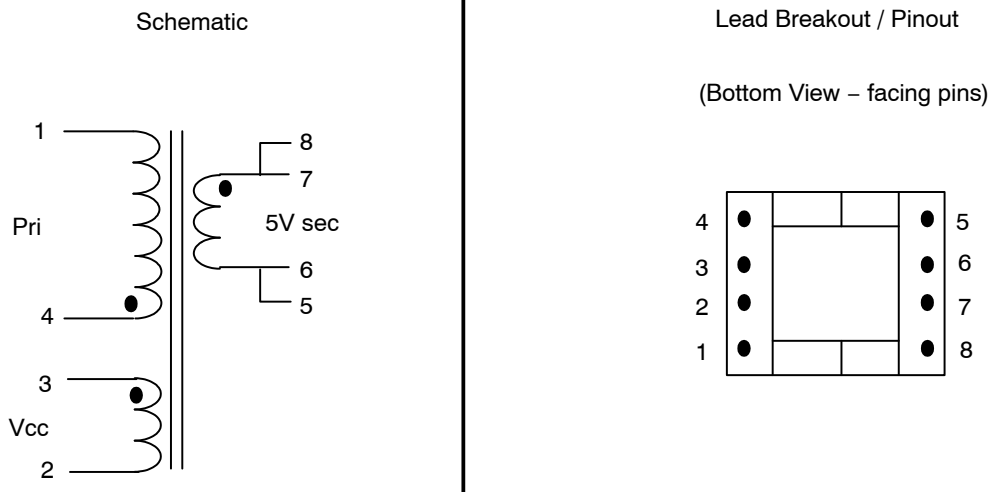

**Figure 4. DCM Flyback Transformer Design**

# NCP1031POEEVB

Part Description: 6.5 W, 220 kHz POE Flyback Transform, 5 V<sub>OUT</sub>, 48 V<sub>IN</sub>

Schematic ID: T1

Core Type: Ferroxcube EF16 (E16/8/5); 3C95 Material Or Similar

Core Gap: Gap for 250  $\mu$ H

Inductance: 250  $\pm$  15  $\mu$ H

Bobbin Type: 8 Pin Horizontal Mount for EF16

**Windings (in order):**

Winding # / Type	Turns / Material / Gauge / Insulation Data
V <sub>CC</sub> / BOOST(2 – 3)	18 turns of #28HN spiral wound over 1 layer. Insulate with 1 layer of tape (250 V insulation to next winding).
Primary(1 – 4)	48 turns of #28HN over 2 layer. Insulate for 1.5 kV to the next winding.
5 V Secondary (5, 6 – 7, 8)	8 turns of 2 strands of #28HN flat wound over 1 layer evenly and terminated with 2 strands per pin. Insulate with tape.

NOTE: Vendor for this transform is Mesa Power Systems (Escondido, CA). Part# 131294.

Hipot: 1.5 kV from V<sub>CC</sub> Boost/Primary to Secondary.

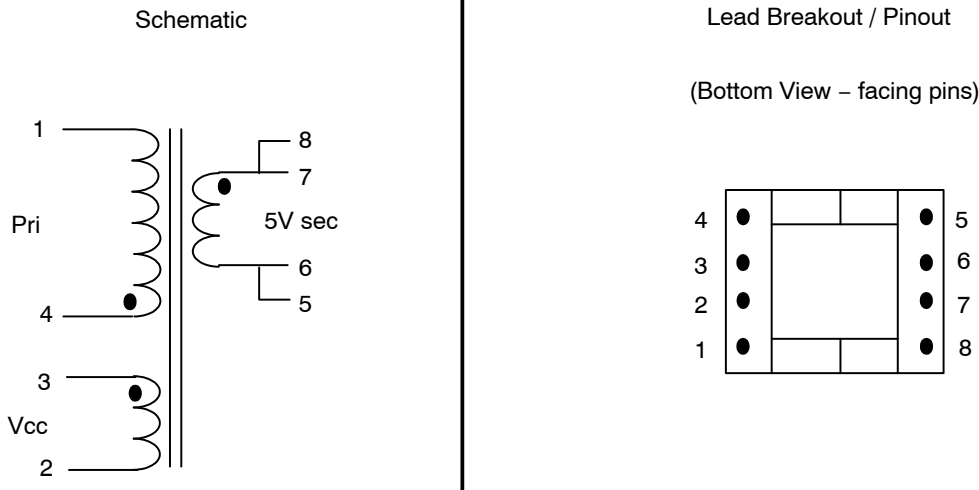

**Figure 5. CCM Flyback Transformer Design**

# NCP1031POEEVB

## TEST PROCEDURE

### Introduction

The POE (Power Over the Ethernet) evaluation board is a 6.5 W DC–DC converter using the ON Semiconductor NCP1031 monolithic controller/mosfet chip in a flyback topology. The input is 48 Vdc nominal and the output is 5 Vdc at 1.3 A maximum. There is additional input circuitry that responds to Ethernet protocol defined as “Signature” and “Classification” detection. Signature just indicates that the power supply does exist and classification allows the upstream Power Sourcing Equipment (PSE) to determine the rated power level of the supply or Powered Device (PD). Both of these detection modes are performed at low input voltages in which the main converter does not operate. The converter will only come on with  $V_{in}$  above 35 Vdc.

### Equipment Required

1. Adjustable bench power supply capable of up to 50 Vdc with an output current of up to 0.5 amps.
2. Digital volt/amp meters to measure input and output current and voltage to the evaluation board.
3. A variable electronic load or rheostat capable of up to a 2 amp load.
4. Oscilloscope with probe to monitor output ripple on the demo converter.

### Setup Procedure

Set the equipment as shown in the Figure 6 so that the input and output voltage and current to the evaluation board can be measured and the output ripple can be monitored.

### Test Procedure

1. Switch the electronic load on and set to zero load; switch all of the digital meters on (assuming they are wired properly for voltage and current sensing); turn the oscilloscope on with sensing in AC mode and 50 mV per division vertical and a sweep rate of 5  $\mu$ S per division. Connect the scope probe to the evaluation board’s output terminals.
2. Set the voltage adjust to zero on the bench supply and switch it on.

3. Adjust the bench supply to 5.00 volts output. The input current meter to the evaluation board should read between 0.190 mA and 0.230 mA. Both evaluation board output meters should read essentially zero.
4. Adjust the bench supply to 18.00 Vdc output. The input current to the board under test should read between 17 and 21 mA.
5. Adjust the bench supply to 48 Vdc output and the converter should start and show an output voltage of 4.9 to 5.1 Vdc. The scope should show less than 50 mV ripple and indicate output stability by a constant, non-jittering trace.
6. Adjust the electronic load slowly from zero to 1.3 amps as evidenced by the output current meter. The output should still be between 4.9 and 5.1 volts and the ripple on the scope should be less than 100 mV and indicate a stable output throughout this load range.
7. With 1.3 amps on the output check the input current and make sure it’s below 200 mA (efficiency check.)
8. Adjust the bench supply slowly down to approximately 35 Vdc. The converter should shut off between 34 and 36 Vdc and the output will go to zero. Adjust the input back to 38 Vdc and the converter should come back on with normal output.
9. Adjust the input voltage back to 48 Vdc and then slowly increase the load to over 1.5 amps. The output voltage should start collapsing around 1.4 to 1.6 amps indicating current limiting.
10. Set the current back to 1.3 amps and allow the evaluation board to run for about 5 minutes to assure that it doesn’t thermally limit by shutting down. Note: This last test may not be necessary after several evaluation boards and the test procedure are validated.
11. Turn the bench supply off and disconnect the evaluation board. Testing is complete.

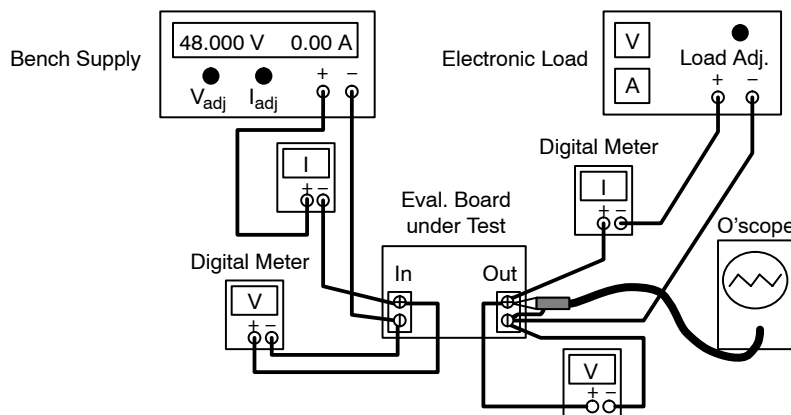

Figure 6. Setup Procedure Diagram

# NCP1031POEEVB

**Table 2. BILL OF MATERIAL FOR THE NCP1031 EVALUATION BOARD**

Designator	Qty.	Description	Value	Tolerance	Footprint	Manufacturer	Manufacturer Part Number	Substitution Allowed	Lead Free
D1	1	Zener Diode	9.1 V	NA	SOD-123	ON Semiconductor	MMSZ5239BT1,G	No	Yes
D6	1	Ultrafast Rectifier	1 A, 100 V	NA	SMA/SMB	ON Semiconductor	MURS110T3	No	Yes
D5	1	Schottky Rectifier	1 A, 40 V	NA	SMC	ON Semiconductor	MBRS340T3,G	No	Yes
D3	1	Zener Diode	15 V	5%	SOD-123	ON Semiconductor	MMSZ5245BT1,G	No	Yes
D2	1	Zener Diode	24 V	5%	SOD-123	ON Semiconductor	MMSZ5252BT1,G	No	Yes
			28 V				MMSZ5255BT1,G		
D4	1	Diode	100 V	NA	SOD-123	ON Semiconductor	MMSD4148,G	No	Yes
Q2	1	NPN Transistor	100 V	NA	SOT-23	ON Semiconductor	MMBT5550L,G	No	Yes
Q1	1	MOSFET	60 V, 115 mA	NA	SOT-23	ON Semiconductor	2N7002LT,G	No	Yes
Q3	1	Power MOSFET	100 V, 12 A	NA	DPAK-3	ON Semiconductor	NTD12N10	No	Yes
U1, U4	2	Programmable Zener	2.5-36 V	1%	SOIC-8	ON Semiconductor	TL431ACD	No	Yes
U3	1	Optocoupler	NA	NA	4 Pin	Vishay	SFH615A-4	No	Yes
U2	1	Integrated Controller	NA	NA	SO-8	ON Semiconductor	NCP1031DR2G	No	Yes
C10	1	WYO "Y" Cap	1.0 nF	20%	LS = 0.25"	Vishay	WYO102MCMBF0KR	No	Yes
C6	1	Ceramic Capacitor	1.0 nF, 100 V	5%	0805	AVX	08051C102JAT2A	Yes	Yes
C1, C3, C8	3	Ceramic Capacitor	10 nF, 100 V	5%	0805	AVX	08051C103JAT2A	Yes	Yes
C9, C13	2	Ceramic Capacitor	0.1 $\mu$ F, 50 V	10%	0805	AVX	08055C104JAT2A	Yes	Yes
C5	1	Ceramic Capacitor	2.2 nF, 1.0 kV	20%	LS = 0.25"	Vishay	562R5GAD22	Yes	Yes
C4	1	Electrolytic Capacitor	47 $\mu$ F or 60 $\mu$ F, 100 V	20%	LS = 0.2"	Rubycon, UCC	100 NA47M 10x20	Yes	Yes
C11	1	Electrolytic Capacitor	1,000 to 1,500 $\mu$ F, 6.3 V	20%	LS = 0.15"	Rubycon, UCC	6.3 NA1000M 10x16	Yes	Yes
C12	1	Electrolytic Capacitor	100 $\mu$ F, 10 V	20%	LS = 0.1"	Rubycon, UCC	10 NA100M 6.3x11	Yes	Yes
C7	1	Electrolytic Capacitor	10 $\mu$ F, 16 V	20%	LS = 0.1"	Rubycon, UCC	16 TWL10M 4x7	Yes	Yes
C2	1	Electrolytic Capacitor	1.0 $\mu$ F to 2.2 $\mu$ F, 35 V	20%	LS = 0.1"	Rubycon, UCC	50 TWL1M 5x11	Yes	Yes
R10	1	Resistor	10 k $\Omega$ , 1/2 W	5%	2010	Vishay	CRCW2010-10K	Yes	Yes
R2	1	Resistor	6.2 k $\Omega$ , 1/2 W	5%	2010	Vishay	CRCW2010-6.19K	Yes	Yes
R4	1	Resistor	137 $\Omega$ , 1/4 W	1%	0805	Vishay	CRCW0805-137	Yes	Yes
R1	1	Resistor	24.9 k $\Omega$ , 1/4 W	1%	0805	Vishay	CRCW0805-24.9K	Yes	Yes
R11	1	Resistor	47 $\Omega$ , 1/4 W	1%	0805	Vishay	CRCW0805-47	Yes	Yes
R13	1	Resistor	180 $\Omega$ , 1/4 W	1%	0805	Vishay	CRCW0805-180	Yes	Yes
R14	1	Resistor	1.0 k $\Omega$ , 1/4 W	1%	0805	Vishay	CRCW0805-1.0K	Yes	Yes
R16, R17	2	Resistor	2.2 k $\Omega$ , 1/4 W	1%	0805	Vishay	CRCW0805-2.2K	Yes	Yes
R9	1	Resistor	6.8 k $\Omega$ , 1/4 W	1%	0805	Vishay	CRCW0805-6.81K	Yes	Yes
R8	1	Resistor	9.1 k $\Omega$ , 1/4 W	1%	0805	Vishay	CRCW0805-9.09K	Yes	Yes
Not Used	0	Resistor (Not Used)	10 k $\Omega$ , 1/4 W	1%	0805	Vishay	CRCW0805-10K	Yes	Yes
R15	1	Resistor	3.3 k $\Omega$ , 1/4 W	1%	0805	Vishay	CRCW0805-3.3K	Yes	Yes
R6	1	Resistor	51 k $\Omega$ , 1/4 W	1%	0805	Vishay	CRCW0805-51.1K	Yes	Yes
R5	1	Resistor	68 k $\Omega$ , 1/4 W	1%	0805	Vishay	CRCW0805-68.1K	Yes	Yes
R7	1	Resistor	200 k $\Omega$ , 1/4 W	1%	0805	Vishay	CRCW0805-200K	Yes	Yes
R3	1	Resistor	470 k $\Omega$ , 1/4 W	1%	0805	Vishay	CRCW0805-470K	Yes	Yes
L1, L2	2	Inductor	4.7 $\mu$ H, 3.0 A	NA	LS = 0.4"	Coilcraft	PCV-0-472-03	No	Yes
T1	1	Transformer, 10 W Flyback (Custom)	NA	NA	TH	Mesa Power Systems	13-1269	No	No
Input, Output	2	Terminal Blocks	-	-	5.08 mm Pitch	On Shore Technology Inc.	OSTYC022150-ND	Yes	Yes



# NCP1031POEEVB

**ON Semiconductor** and **ON** are registered trademarks of Semiconductor Components Industries, LLC (SCILLC). SCILLC owns the rights to a number of patents, trademarks, copyrights, trade secrets, and other intellectual property. A listing of SCILLC's product/patent coverage may be accessed at [www.onsemi.com/site/pdf/Patent-Marking.pdf](http://www.onsemi.com/site/pdf/Patent-Marking.pdf). SCILLC reserves the right to make changes without further notice to any products herein. SCILLC makes no warranty, representation or guarantee regarding the suitability of its products for any particular purpose, nor does SCILLC assume any liability arising out of the application or use of any product or circuit, and specifically disclaims any and all liability, including without limitation special, consequential or incidental damages. "Typical" parameters which may be provided in SCILLC data sheets and/or specifications can and do vary in different applications and actual performance may vary over time. All operating parameters, including "Typicals" must be validated for each customer application by customer's technical experts. SCILLC does not convey any license under its patent rights nor the rights of others. SCILLC products are not designed, intended, or authorized for use as components in systems intended for surgical implant into the body, or other applications intended to support or sustain life, or for any other application in which the failure of the SCILLC product could create a situation where personal injury or death may occur. Should Buyer purchase or use SCILLC products for any such unintended or unauthorized application, Buyer shall indemnify and hold SCILLC and its officers, employees, subsidiaries, affiliates, and distributors harmless against all claims, costs, damages, and expenses, and reasonable attorney fees arising out of, directly or indirectly, any claim of personal injury or death associated with such unintended or unauthorized use, even if such claim alleges that SCILLC was negligent regarding the design or manufacture of the part. SCILLC is an Equal Opportunity/Affirmative Action Employer. This literature is subject to all applicable copyright laws and is not for resale in any manner.

## PUBLICATION ORDERING INFORMATION

### LITERATURE FULFILLMENT:

Literature Distribution Center for ON Semiconductor  
P.O. Box 5163, Denver, Colorado 80217 USA  
**Phone:** 303-675-2175 or 800-344-3860 Toll Free USA/Canada  
**Fax:** 303-675-2176 or 800-344-3867 Toll Free USA/Canada  
**Email:** [orderlit@onsemi.com](mailto:orderlit@onsemi.com)

**N. American Technical Support:** 800-282-9855 Toll Free  
USA/Canada  
**Europe, Middle East and Africa Technical Support:**  
Phone: 421 33 790 2910  
**Japan Customer Focus Center**  
Phone: 81-3-5817-1050

**ON Semiconductor Website:** [www.onsemi.com](http://www.onsemi.com)  
**Order Literature:** <http://www.onsemi.com/orderlit>  
For additional information, please contact your local  
Sales Representative

Компания «Океан Электроники» предлагает заключение долгосрочных отношений при поставках импортных электронных компонентов на взаимовыгодных условиях!

Наши преимущества:

- Поставка оригинальных импортных электронных компонентов напрямую с производств Америки, Европы и Азии, а так же с крупнейших складов мира;
- Широкая линейка поставок активных и пассивных импортных электронных компонентов (более 30 млн. наименований);
- Поставка сложных, дефицитных, либо снятых с производства позиций;
- Оперативные сроки поставки под заказ (от 5 рабочих дней);
- Экспресс доставка в любую точку России;
- Помощь Конструкторского Отдела и консультации квалифицированных инженеров;
- Техническая поддержка проекта, помощь в подборе аналогов, поставка прототипов;
- Поставка электронных компонентов под контролем ВП;
- Система менеджмента качества сертифицирована по Международному стандарту ISO 9001;
- При необходимости вся продукция военного и аэрокосмического назначения проходит испытания и сертификацию в лаборатории (по согласованию с заказчиком);
- Поставка специализированных компонентов военного и аэрокосмического уровня качества (Xilinx, Altera, Analog Devices, Intersil, Interpoint, Microsemi, Actel, Aeroflex, Peregrine, VPT, Syfer, Eurofarad, Texas Instruments, MS Kennedy, Miteq, Cobham, E2V, MA-COM, Hittite, Mini-Circuits, General Dynamics и др.);

Компания «Океан Электроники» является официальным дистрибьютором и эксклюзивным представителем в России одного из крупнейших производителей разъемов военного и аэрокосмического назначения «JONHON», а так же официальным дистрибьютором и эксклюзивным представителем в России производителя высокотехнологичных и надежных решений для передачи СВЧ сигналов «FORSTAR».



## JONHON

«JONHON» (основан в 1970 г.)

Разъемы специального, военного и аэрокосмического назначения:

(Применяются в военной, авиационной, аэрокосмической, морской, железнодорожной, горно- и нефтедобывающей отраслях промышленности)

«FORSTAR» (основан в 1998 г.)

ВЧ соединители, коаксиальные кабели, кабельные сборки и микроволновые компоненты:

(Применяются в телекоммуникациях гражданского и специального назначения, в средствах связи, РЛС, а так же военной, авиационной и аэрокосмической отраслях промышленности).



Телефон: 8 (812) 309-75-97 (многоканальный)

Факс: 8 (812) 320-03-32

Электронная почта: [ocean@oceanchips.ru](mailto:ocean@oceanchips.ru)

Web: <http://oceanchips.ru/>

Адрес: 198099, г. Санкт-Петербург, ул. Калинина, д. 2, корп. 4, лит. А