

Automotive-grade dual N-channel 60 V, 35 mΩ typ., 6.5 A STripFET™ F3 Power MOSFET in PowerFLAT™ 5x6 double island

Datasheet - production data

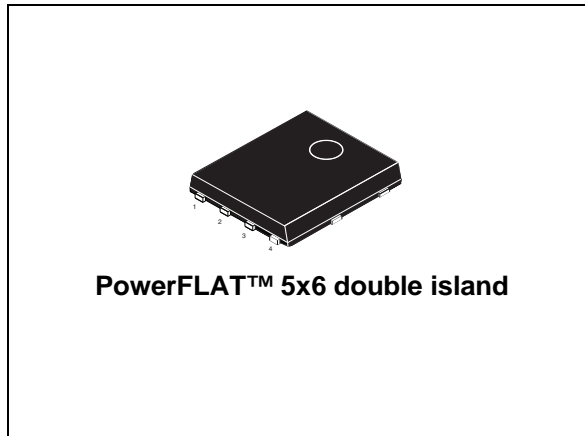
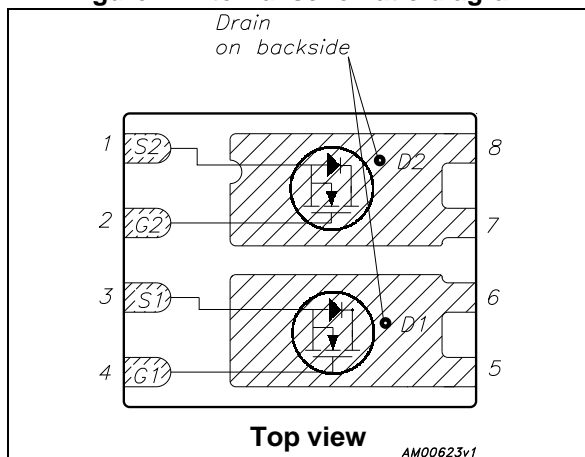

Figure 1. Internal schematic diagram



Features

Order code	V _{DS}	R _{DS(on)} max	I _D
STL7DN6LF3	60 V	43 mΩ	6.5 A

- Designed for automotive application and AEC-Q101 qualified
- Logic level V_{GS(th)}
- 175 °C junction temperature
- 100% avalanche rated
- Wettable flank package

Applications

- Switching applications

Description

This device is a dual N-channel Power MOSFET developed using STripFET™ F3 technology. It is designed to minimize on-resistance and gate charge to provide superior switching performance.

Table 1. Device summary

Order code	Marking	Package	Packaging
STL7DN6LF3	7DN6LF3	PowerFLAT™ 5x6 double island ⁽¹⁾	Tape and reel

1. For wettable flank option, please contact ST sale offices.

Contents

1	Electrical ratings	3
2	Electrical characteristics	4
2.1	Electrical characteristics (curves)	6
3	Test circuits	8
4	Package information	9
5	Packaging information	15
6	Revision history	17

1 Electrical ratings

Table 2. Absolute maximum ratings

Symbol	Parameter	Value	Unit
V_{DS}	Drain-source voltage	60	V
V_{GS}	Gate-source voltage	± 20	V
$I_D^{(1),(2)}$	Drain current (continuous) at $T_C = 25^\circ\text{C}$	20	A
$I_D^{(1)}$	Drain current (continuous) at $T_C = 100^\circ\text{C}$	16	A
$I_D^{(4)}$	Drain current (continuous) at $T_{pcb} = 25^\circ\text{C}$	6.5	A
$I_D^{(4)}$	Drain current (continuous) at $T_{pcb}=100^\circ\text{C}$	4.6	A
$I_{DM}^{(3),(4)}$	Drain current (pulsed)	26	A
P_{TOT}	Total dissipation at $T_C = 25^\circ\text{C}$	52	W
$P_{TOT}^{(4)}$	Total dissipation at $T_{pcb} = 25^\circ\text{C}$	4.3	W
I_{AV}	Not-repetitive avalanche current	6.5	A
$E_{AS}^{(5)}$	Single pulse avalanche energy	190	mJ
T_J T_{stg}	Operating junction temperature Storage temperature	-55 to 175	$^\circ\text{C}$

1. Specified by design. Not subject to production test.
2. Current is limited by bonding, with an $R_{thJC} = 2.9^\circ\text{C/W}$ the chip is able to carry 22 A at 25°C .
3. Pulse width limited by safe operating area
4. When mounted on FR-4 board of 1inch^2 , 2oz Cu, $t < 10\text{ sec}$
5. Starting $T_J = 25^\circ\text{C}$, $I_D = 8\text{ A}$, $V_{DD} = 25\text{ V}$

Table 3. Thermal resistance

Symbol	Parameter	Value	Unit
$R_{thj-case}$	Thermal resistance junction-case	2.9	$^\circ\text{C/W}$
$R_{thj-pcb}^{(1)}$	Thermal resistance junction-pcb	35	$^\circ\text{C/W}$

1. When mounted on FR-4 board of 1inch^2 , 2oz Cu, $t < 10\text{ sec}$

2 Electrical characteristics

($T_{CASE} = 25\text{ °C}$ unless otherwise specified)

Table 4. On/off states

Symbol	Parameter	Test conditions	Min.	Typ.	Max.	Unit
$V_{(BR)DSS}$	Drain-source breakdown voltage ($V_{GS} = 0$)	$I_D = 250\ \mu\text{A}$	60			V
I_{DSS}	Zero gate voltage drain current ($V_{GS} = 0$)	$V_{DS} = 60\ \text{V}$			1	μA
I_{GSS}	Gate body leakage current ($V_{DS} = 0$)	$V_{GS} = \pm 20\ \text{V}$			± 100	nA
$V_{GS(th)}$	Gate threshold voltage	$V_{DS} = V_{GS}$, $I_D = 250\ \mu\text{A}$	1		2.5	V
$R_{DS(on)}$	Static drain-source on-resistance	$V_{GS} = 10\ \text{V}$, $I_D = 3\ \text{A}$ $V_{GS} = 5\ \text{V}$, $I_D = 3\ \text{A}$		35 48	43 60	$\text{m}\Omega$ $\text{m}\Omega$

Table 5. Dynamic

Symbol	Parameter	Test conditions	Min.	Typ.	Max.	Unit
C_{iss}	Input capacitance	$V_{DS} = 25\ \text{V}$, $f = 1\ \text{MHz}$, $V_{GS} = 0$	-	432	-	pF
C_{oss}	Output capacitance		-	93	-	pF
C_{rss}	Reverse transfer capacitance		-	10.5	-	pF
Q_g	Total gate charge	$V_{DD} = 30\ \text{V}$, $I_D = 6.5\ \text{A}$ $V_{GS} = 10\ \text{V}$, Figure 13	-	8.7	-	nC
Q_{gs}	Gate-source charge		-	1.9	-	nC
Q_{gd}	Gate-drain charge		-	1.9	-	nC
R_G	Intrinsic gate resistance	$f = 1\ \text{MHz}$ open drain	-	6.3	-	Ω

Table 6. Switching times

Symbol	Parameter	Test conditions	Min.	Typ.	Max.	Unit
$t_{d(on)}$	Turn-on delay time	$V_{DD} = 30\ \text{V}$, $I_D = 3\ \text{A}$, $R_G = 4.7\ \Omega$, $V_{GS} = 10\ \text{V}$ Figure 12	-	6.7	-	ns
t_r	Rise time		-	10.4	-	ns
$t_{d(off)}$	Turn-off delay time		-	32.4	-	ns
t_f	Fall time		-	5.4	-	ns

Table 7. Source drain diode

Symbol	Parameter	Test conditions	Min	Typ.	Max	Unit
I_{SD}	Source-drain current		-		6.5	A
$I_{SDM}^{(1)}$	Source-drain current (pulsed)		-		26	A
$V_{SD}^{(2)}$	Forward on voltage	$I_{SD} = 6.5 \text{ A}, V_{GS} = 0$	-		1.3	V
t_{rr}	Reverse recovery time	$I_{SD} = 6.5 \text{ A},$ $di/dt = 100 \text{ A}/\mu\text{s},$ $V_{DD} = 48 \text{ V}, T_j = 150 \text{ }^\circ\text{C}$	-	24	-	ns
Q_{rr}	Reverse recovery charge		-	23.3	-	nC
I_{RRM}	Reverse recovery current		-	1.94	-	A

1. Pulse width limited by safe operating area
2. Pulsed: pulse duration= 300 μs , duty cycle 1.5%

2.1 Electrical characteristics (curves)

Figure 2. Safe operating area

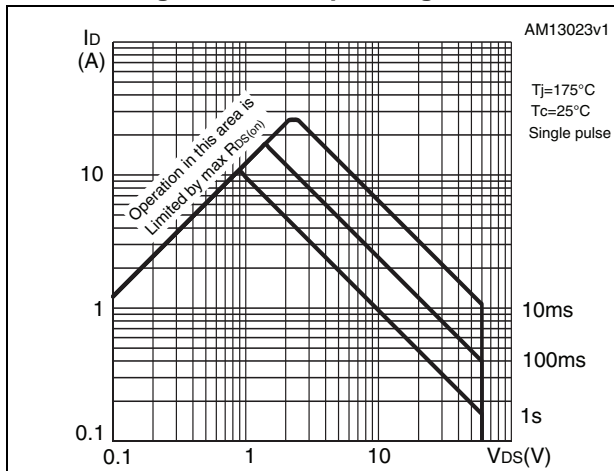

Figure 3. Thermal impedance

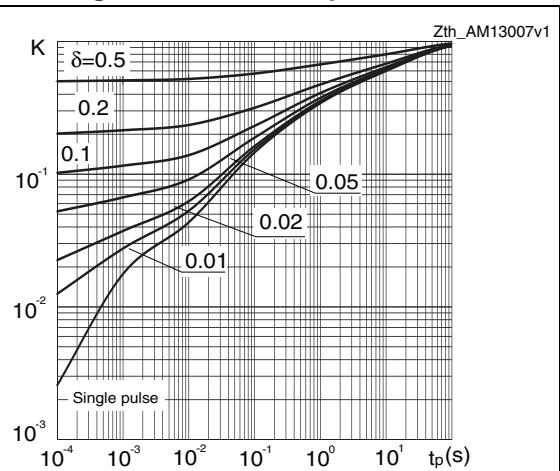

Figure 4. Output characteristics

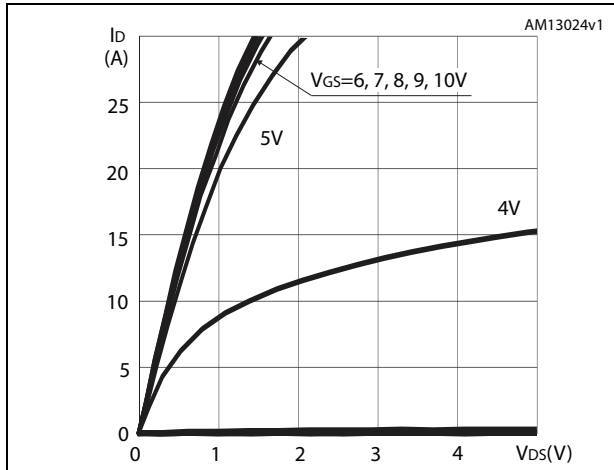

Figure 5. Transfer characteristics

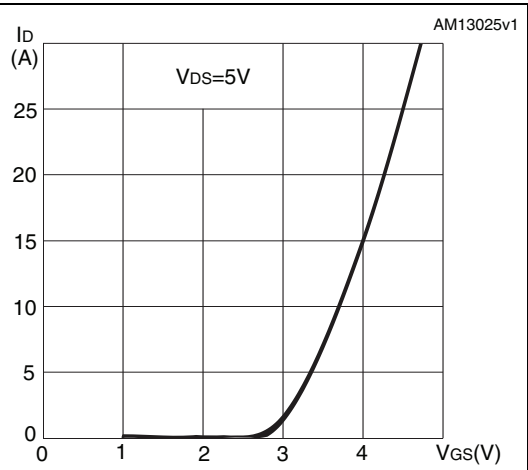

Figure 6. Normalized $V_{(BR)DSS}$ vs temperature

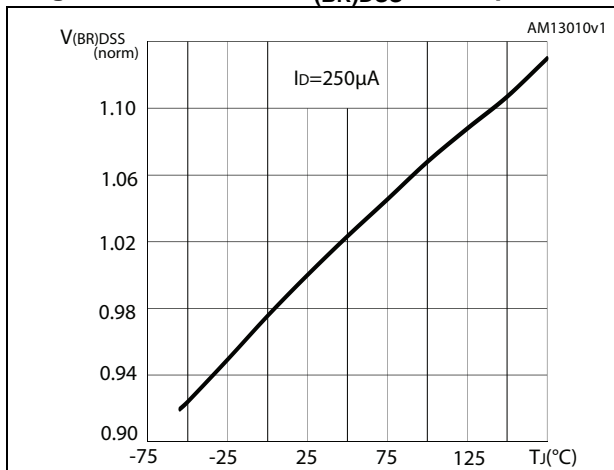

Figure 7. Static drain-source on-resistance

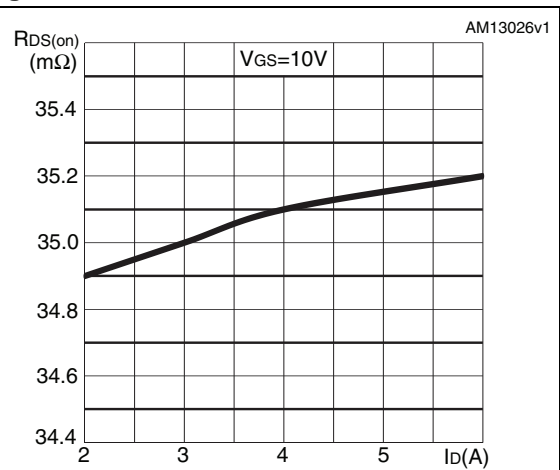

Figure 8. Gate charge vs gate-source voltage

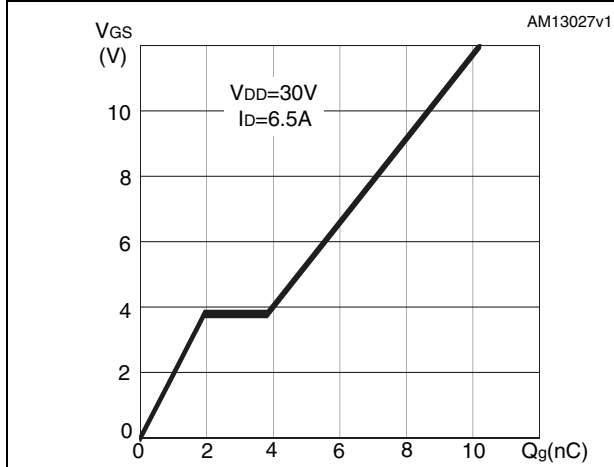

Figure 9. Capacitance variations

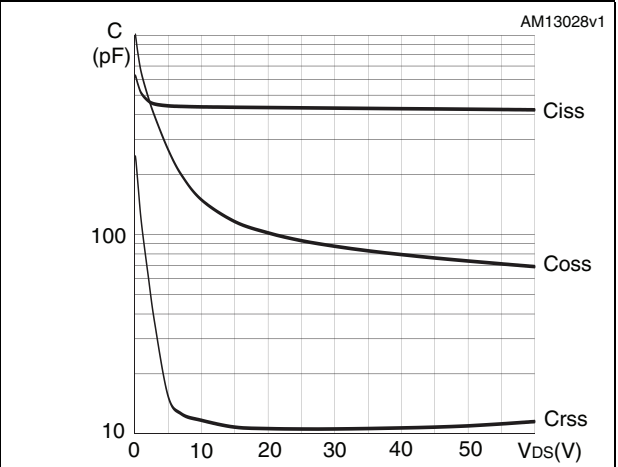

Figure 10. Normalized gate threshold voltage vs temperature

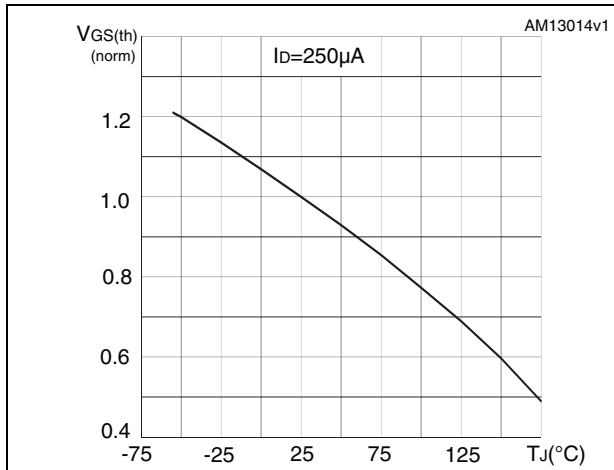
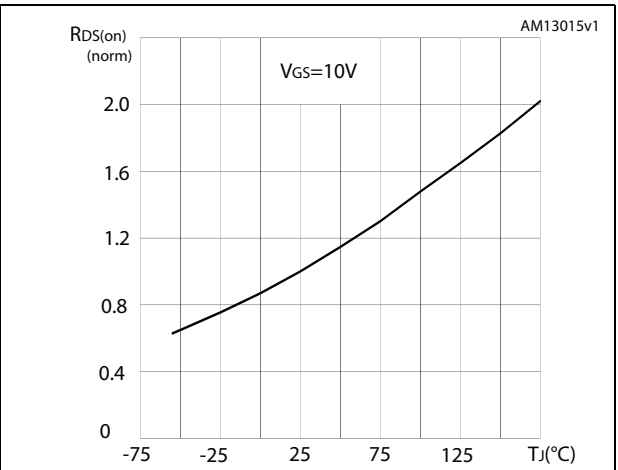

Figure 11. Normalized on-resistance vs temperature



3 Test circuits

Figure 12. Switching times test circuit for resistive load

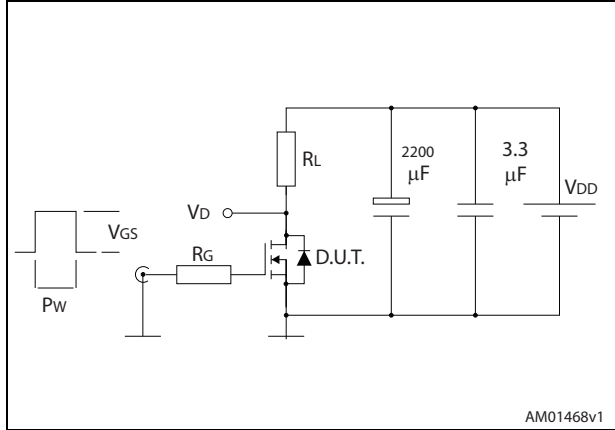

Figure 13. Gate charge test circuit

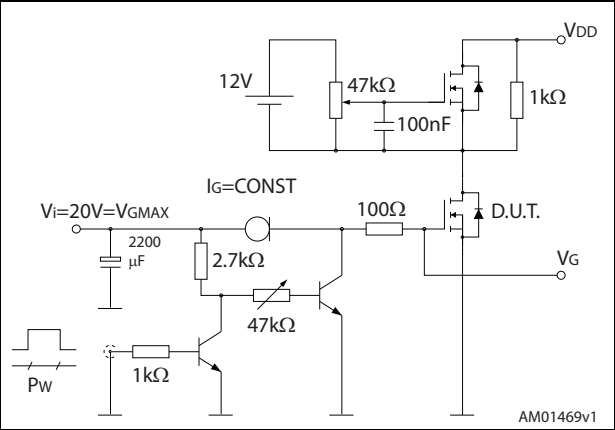

Figure 14. Test circuit for inductive load switching and diode recovery times

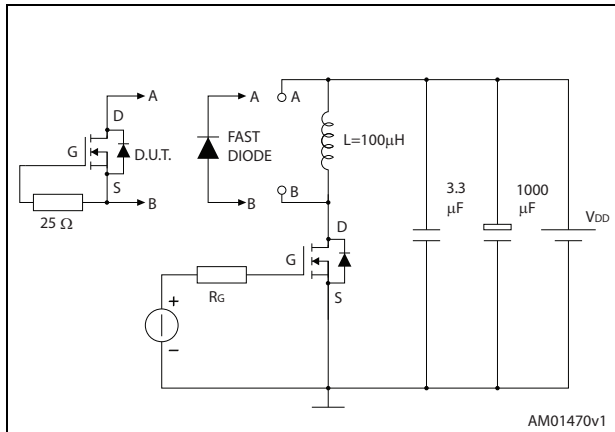

Figure 15. Unclamped inductive load test circuit

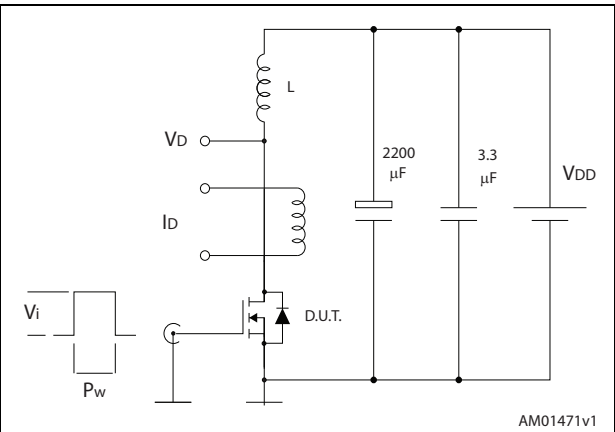

Figure 16. Unclamped inductive waveform

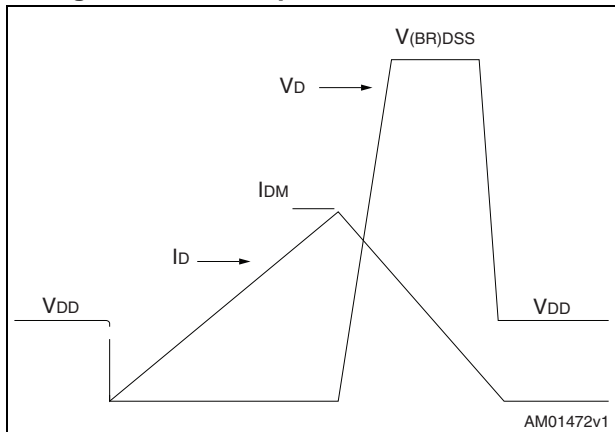
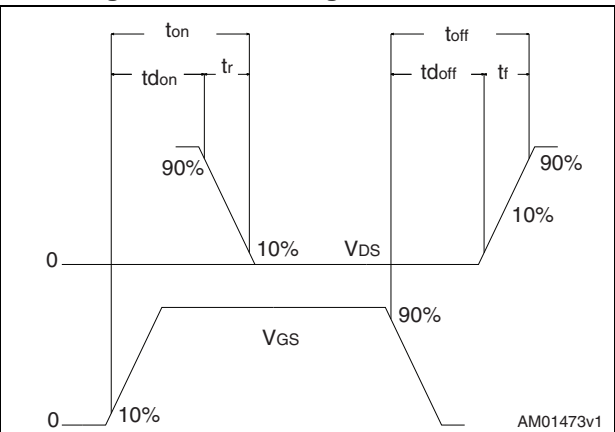

Figure 17. Switching time waveform



4 Package information

In order to meet environmental requirements, ST offers these devices in different grades of ECOPACK[®] packages, depending on their level of environmental compliance. ECOPACK[®] specifications, grade definitions and product status are available at: www.st.com. ECOPACK is an ST trademark.

Figure 18. PowerFLAT 5x6 double island type R outline

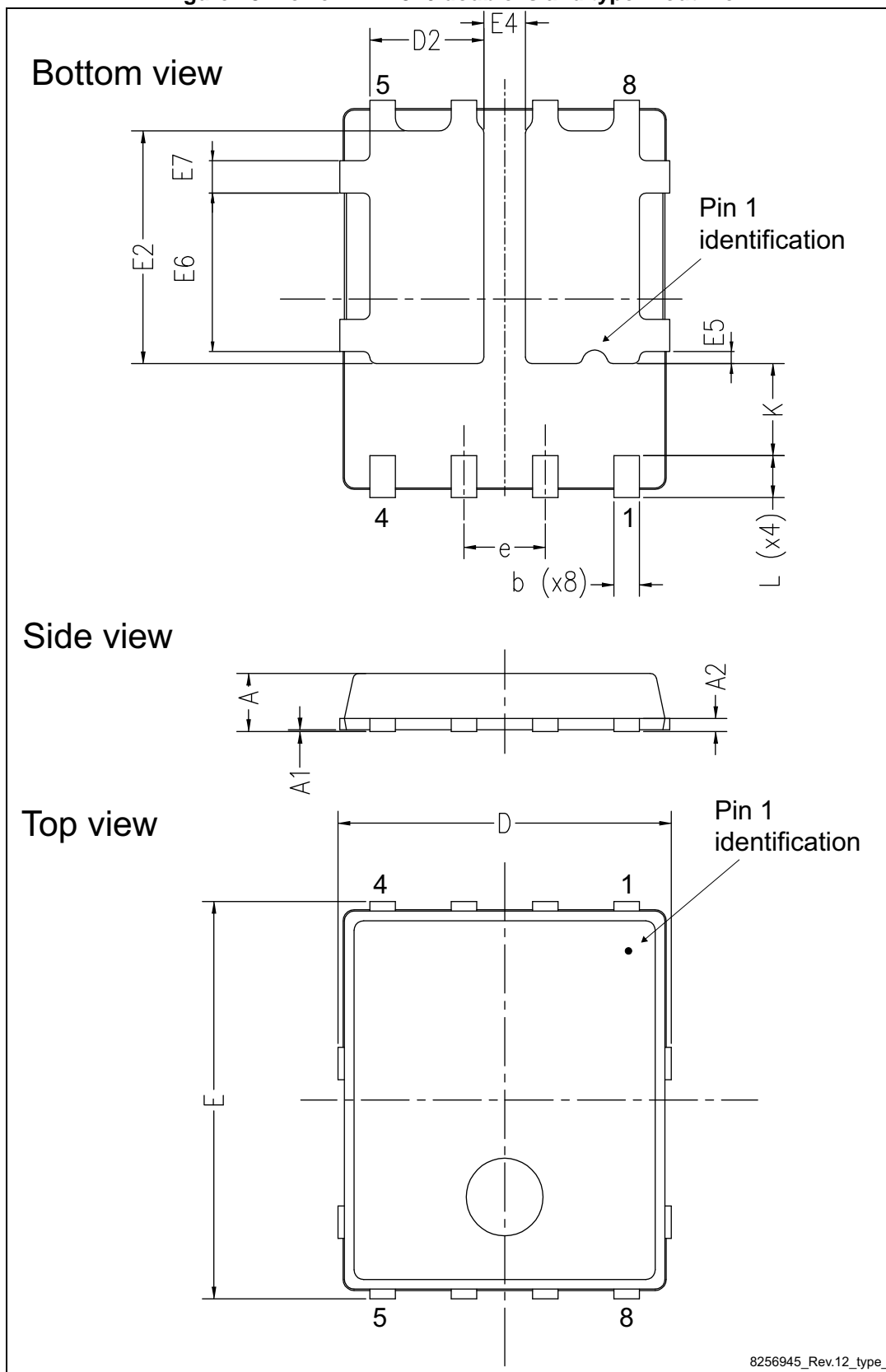

8256945_Rev.12_type_I

Table 8. PowerFLAT 5x6 double island type R mechanical data

Ref.	Dimensions (mm)		
	Min.	Typ.	Max.
A	0.80		1.00
A1	0.02		0.05
A2		0.25	
b	0.30		0.50
D	5.00	5.20	5.40
D2	1.68		1.88
E	5.95	6.15	6.35
E2	3.50		3.70
E4	0.55		0.75
E5	0.08		0.28
E6	2.35		2.55
E7	0.40		0.60
e		1.27	
L	0.60		0.80
K	1.275		1.575

Figure 19. PowerFLAT 5x6 double island WF type R outline

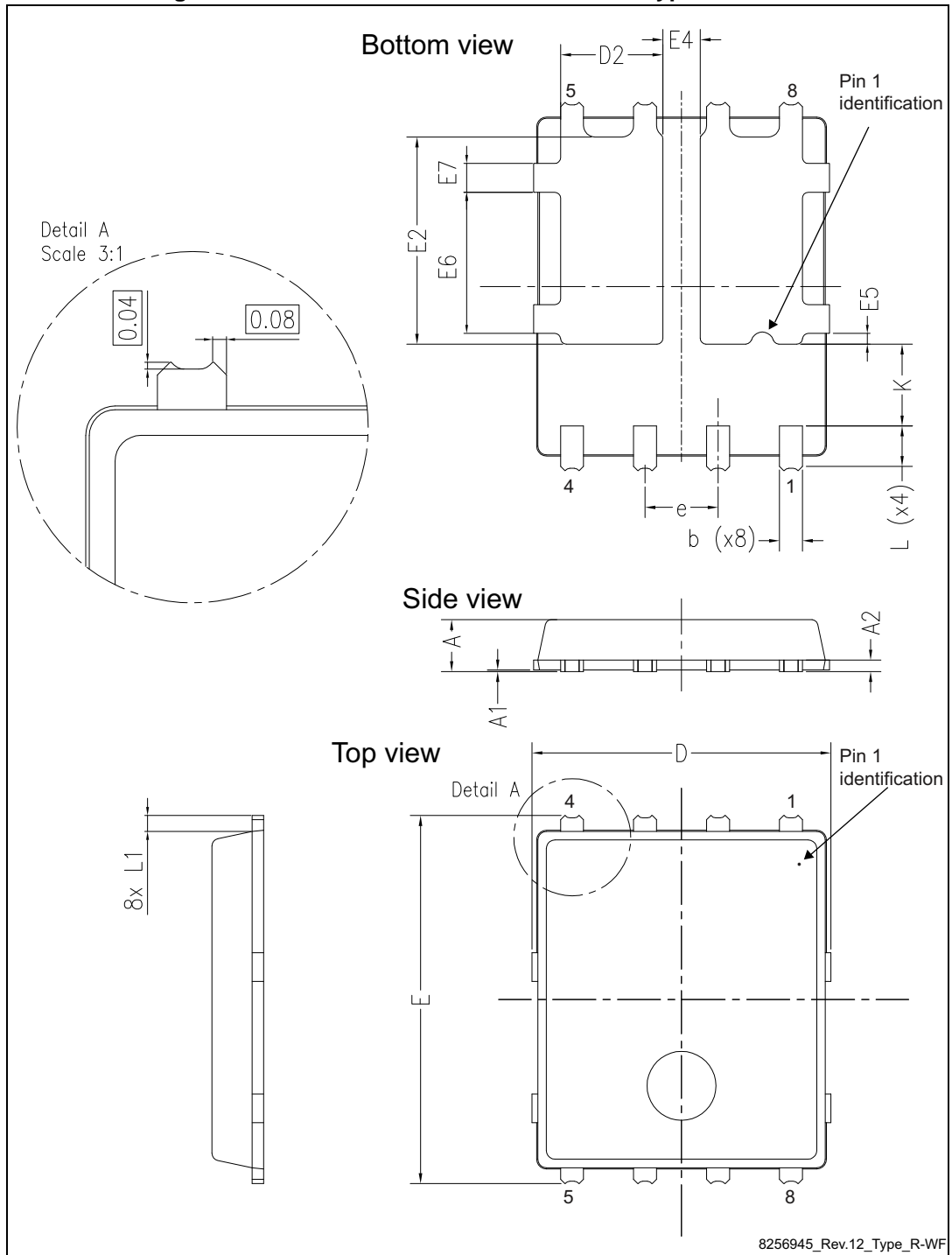

Table 9. PowerFLAT 5x6 double island WF type R mechanical data

Ref.	Dimensions (mm)		
	Min.	Typ.	Max.
A	0.80		1.00
A1	0.02		0.05
A2		0.25	
b	0.30		0.50
D	5.00	5.20	5.40
D2	1.68		1.88
E	6.20	6.40	6.60
E2	3.50		3.70
E4	0.55		0.75
E5	0.08		0.28
E6	2.35		2.55
E7	0.40		0.60
e		1.27	
L	0.70		0.90
L1		0.275	
K	1.275		1.575

5 Packaging information

Figure 21. PowerFLAT™ 5x6 tape^(a)

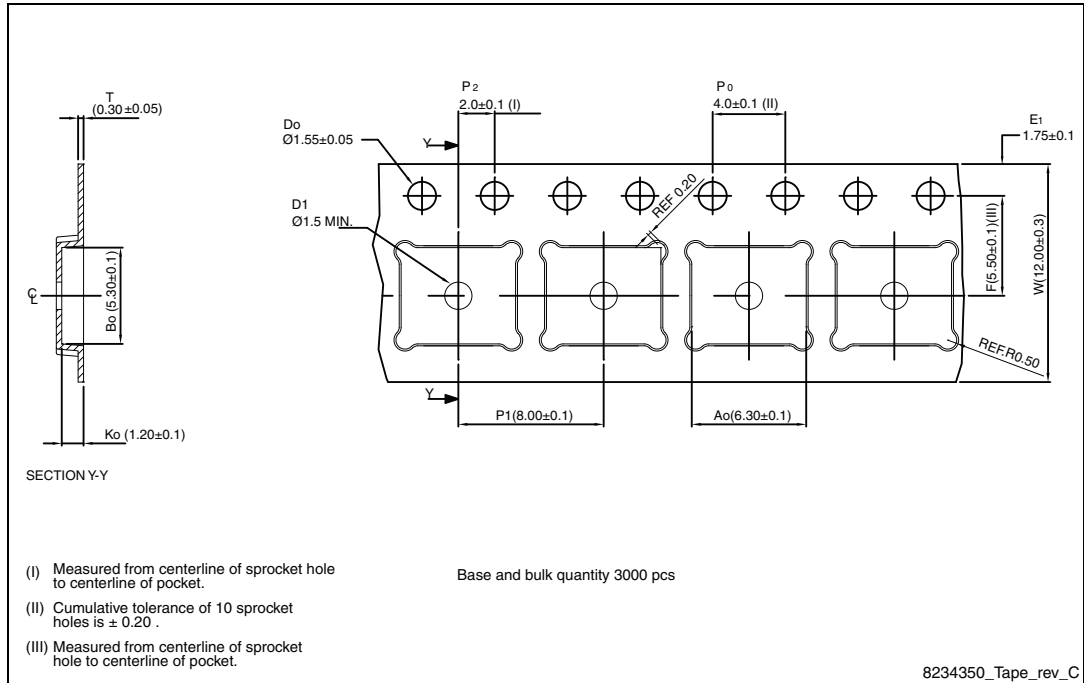
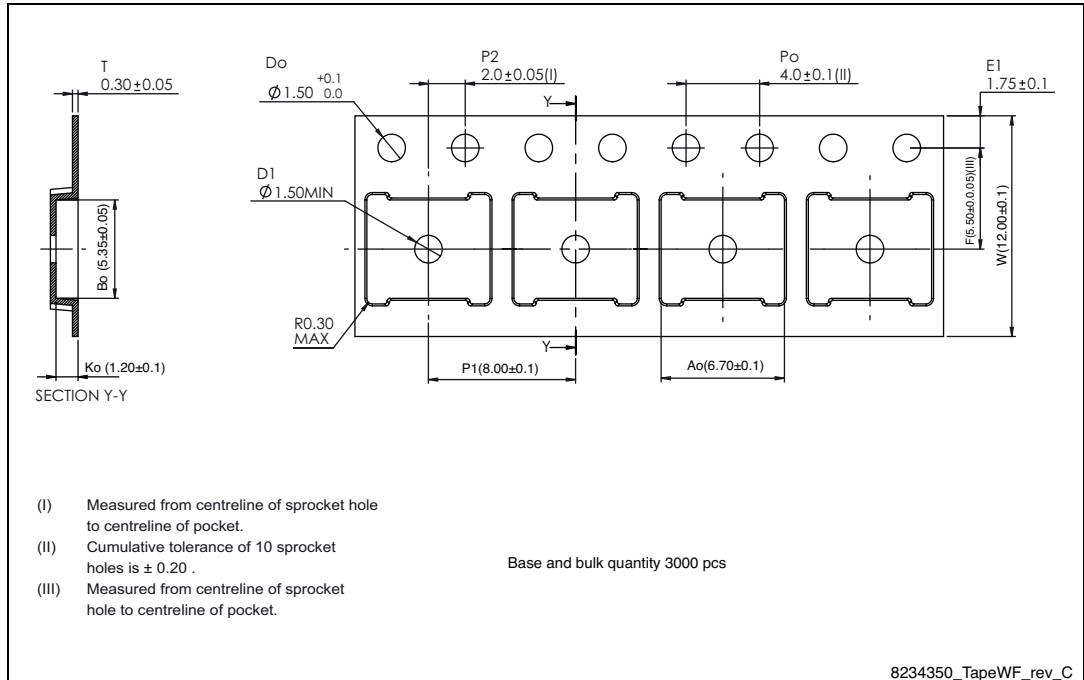

Figure 22. PowerFLAT 5x6 WF tape^(a)



a. All dimensions are in millimeters.

Figure 23. PowerFLAT™ 5x6 package orientation in carrier tape

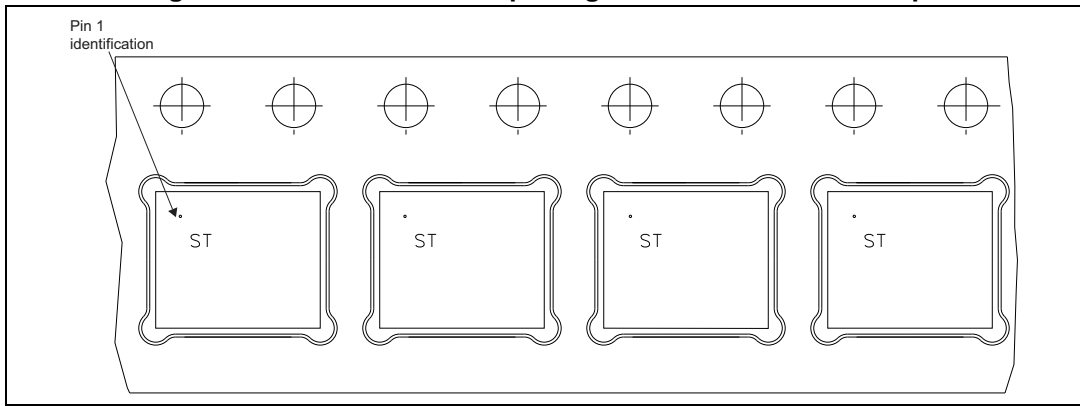
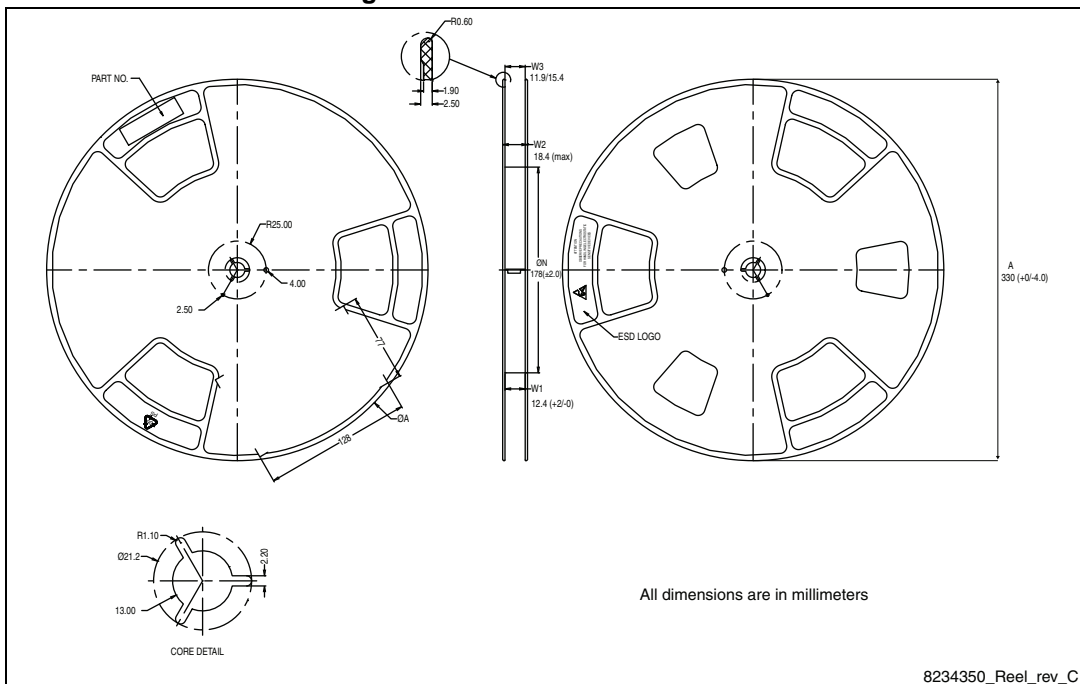

Figure 24. PowerFLAT™ 5x6 reel



8234350_Reel_rev_C

6 Revision history

Table 10. Document revision history

Date	Revision	Changes
28-Mar-2012	1	First release.
19-Jun-2012	2	Section 2.1: Electrical characteristics (curves) has been added. Updated Section 4: Package information and tile on the coverpage.
26-Jun-2012	3	Document status promoted from preliminary to production data.
23-Feb-2015	4	Updated title, features and description in cover page. Updated Table 5: Dynamic , Table 6: Switching times and Section 2.1: Electrical characteristics (curves) . Updated Section 4: Package information . Added Section 5: Packaging information . Minor text changes.

IMPORTANT NOTICE – PLEASE READ CAREFULLY

STMicroelectronics NV and its subsidiaries ("ST") reserve the right to make changes, corrections, enhancements, modifications, and improvements to ST products and/or to this document at any time without notice. Purchasers should obtain the latest relevant information on ST products before placing orders. ST products are sold pursuant to ST's terms and conditions of sale in place at the time of order acknowledgement.

Purchasers are solely responsible for the choice, selection, and use of ST products and ST assumes no liability for application assistance or the design of Purchasers' products.

No license, express or implied, to any intellectual property right is granted by ST herein.

Resale of ST products with provisions different from the information set forth herein shall void any warranty granted by ST for such product.

ST and the ST logo are trademarks of ST. All other product or service names are the property of their respective owners.

Information in this document supersedes and replaces information previously supplied in any prior versions of this document.

© 2015 STMicroelectronics – All rights reserved

Компания «Океан Электроники» предлагает заключение долгосрочных отношений при поставках импортных электронных компонентов на взаимовыгодных условиях!

Наши преимущества:

- Поставка оригинальных импортных электронных компонентов напрямую с производств Америки, Европы и Азии, а так же с крупнейших складов мира;
- Широкая линейка поставок активных и пассивных импортных электронных компонентов (более 30 млн. наименований);
- Поставка сложных, дефицитных, либо снятых с производства позиций;
- Оперативные сроки поставки под заказ (от 5 рабочих дней);
- Экспресс доставка в любую точку России;
- Помощь Конструкторского Отдела и консультации квалифицированных инженеров;
- Техническая поддержка проекта, помощь в подборе аналогов, поставка прототипов;
- Поставка электронных компонентов под контролем ВП;
- Система менеджмента качества сертифицирована по Международному стандарту ISO 9001;
- При необходимости вся продукция военного и аэрокосмического назначения проходит испытания и сертификацию в лаборатории (по согласованию с заказчиком);
- Поставка специализированных компонентов военного и аэрокосмического уровня качества (Xilinx, Altera, Analog Devices, Intersil, Interpoint, Microsemi, Actel, Aeroflex, Peregrine, VPT, Syfer, Eurofarad, Texas Instruments, MS Kennedy, Miteq, Cobham, E2V, MA-COM, Hittite, Mini-Circuits, General Dynamics и др.);

Компания «Океан Электроники» является официальным дистрибьютором и эксклюзивным представителем в России одного из крупнейших производителей разъемов военного и аэрокосмического назначения «JONHON», а так же официальным дистрибьютором и эксклюзивным представителем в России производителя высокотехнологичных и надежных решений для передачи СВЧ сигналов «FORSTAR».



JONHON

«JONHON» (основан в 1970 г.)

Разъемы специального, военного и аэрокосмического назначения:

(Применяются в военной, авиационной, аэрокосмической, морской, железнодорожной, горно- и нефтедобывающей отраслях промышленности)

«FORSTAR» (основан в 1998 г.)

ВЧ соединители, коаксиальные кабели,
кабельные сборки и микроволновые компоненты:

(Применяются в телекоммуникациях гражданского и специального назначения, в средствах связи, РЛС, а так же военной, авиационной и аэрокосмической отраслях промышленности).



Телефон: 8 (812) 309-75-97 (многоканальный)

Факс: 8 (812) 320-03-32

Электронная почта: ocean@oceanchips.ru

Web: <http://oceanchips.ru/>

Адрес: 198099, г. Санкт-Петербург, ул. Калинина, д. 2, корп. 4, лит. А