



# Differential LVPECL/LVECL/HSTL Receiver/Drivers

MAX9321/MAX9321A

## General Description

The MAX9321/MAX9321A are low-skew differential receiver/drivers designed for clock and data distribution. The differential input can be adapted to accept a single-ended input by connecting the on-chip  $V_{BB}$  supply to an input as a reference voltage.

The MAX9321/MAX9321A feature ultra-low propagation delay (172ps) and part-to-part skew (20ps) with 24mA maximum supply current, making these devices ideal for clock buffering or repeating. For interfacing to differential HSTL and LVPECL signals, these devices operate over a +2.25V to +3.8V supply range, allowing high-performance clock and data distribution in systems with a nominal +2.5V or +3.3V supply. For differential LVECL operation, these devices operate from a -2.25V to -3.8V supply. Multiple pinouts are provided to simplify routing across a backplane to either side of a double-sided board.

Both devices are offered in space-saving 8-pin SOT23, SO, and  $\mu$ MAX packages.

## Features

- ◆ Improved Second Source of the MC10LVEP16 (MAX9321)
- ◆ +2.25V to +3.8V Differential HSTL/LVPECL Operation
- ◆ -2.25V to -3.8V Differential LVECL Operation
- ◆ Low 17mA Supply Current
- ◆ 20ps Part-to-Part Skew
- ◆ 172ps Propagation Delay
- ◆ Minimum 300mV Output at 3GHz
- ◆ Output Low for Open Input
- ◆ ESD Protection >2kV (Human Body Model)
- ◆ On-Chip Reference for Single-Ended Input
- ◆ Available in Thermally Enhanced Exposed-Pad SO Package

## Applications

- Precision Clock Buffers
- Low-Jitter Data Repeaters

## Ordering Information

PART	TEMP RANGE	PIN-PACKAGE	TOP MARK
MAX9321EKA-T	-40°C to +85°C	8 SOT23-8	AALK
MAX9321EUA*	-40°C to +85°C	8 $\mu$ MAX	—
MAX9321ESA	-40°C to +85°C	8 SO	—
MAX9321A EKA-T	-40°C to +85°C	8 SOT23-8	AAIX
MAX9321AEUA*	-40°C to +85°C	8 $\mu$ MAX	—
MAX9321AES A	-40°C to +85°C	8 SO-EP**	—

\*Future product—contact factory for availability.

\*\*EP = Exposed pad.

## Pin Configurations

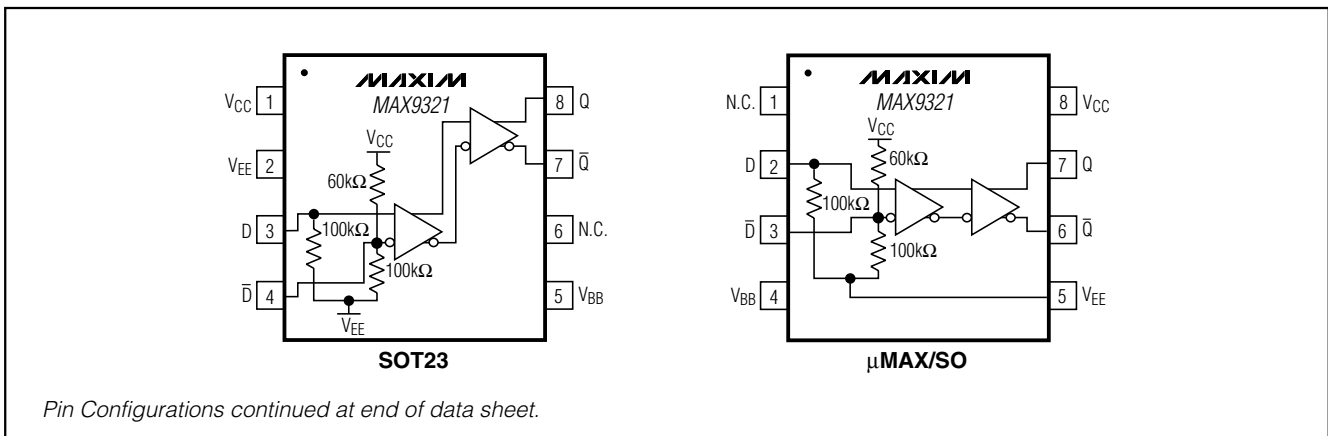

# Differential LVPECL/LVECL/HSTL Receiver/Drivers

## ABSOLUTE MAXIMUM RATINGS

V <sub>CC</sub> to V <sub>EE</sub> .....	+4.1V
D or $\bar{D}$ .....	V <sub>EE</sub> - 0.3V to V <sub>CC</sub> + 0.3V
D to $\bar{D}$ .....	±3.0V
Continuous Output Current .....	50mA
Surge Output Current .....	100mA
V <sub>BB</sub> Sink/Source Current .....	±0.6mA
Junction-to-Ambient Thermal Resistance in Still Air	
8-Pin SOT23 .....	+112°C/W
8-Pin $\mu$ MAX .....	+221°C/W
8-Pin SO-EP .....	+53°C/W
Junction-to-Ambient Thermal Resistance with 500 LFPM Airflow	
8-Pin SOT23 .....	+78°C/W
8-Pin $\mu$ MAX .....	+155°C/W
8-Pin SO .....	+99°C/W

## Junction-to-Case Thermal Resistance

8-Pin SOT23 .....	+80°C/W
8-Pin $\mu$ MAX .....	+39°C/W
8-Pin SO .....	+40°C/W
Operating Temperature Range .....	-40°C to +85°C
Junction Temperature .....	+150°C
Storage Temperature Range .....	-65°C to +150°C
ESD Protection	
Human Body Model (D, $\bar{D}$ , Q, $\bar{Q}$ , V <sub>BB</sub> ) .....	>2kV
Soldering Temperature (10s) .....	+300°C

Stresses beyond those listed under "Absolute Maximum Ratings" may cause permanent damage to the device. These are stress ratings only, and functional operation of the device at these or any other conditions beyond those indicated in the operational sections of the specifications is not implied. Exposure to absolute maximum rating conditions for extended periods may affect device reliability.

## DC ELECTRICAL CHARACTERISTICS

(V<sub>CC</sub> - V<sub>EE</sub> = +2.25V to +3.8V, outputs loaded with 50 $\Omega$  ±1% to V<sub>CC</sub> - 2.0V. Typical values are at V<sub>CC</sub> - V<sub>EE</sub> = +3.3V, V<sub>IHD</sub> = V<sub>CC</sub> - 1V, V<sub>ILD</sub> = V<sub>CC</sub> - 1.5V, unless otherwise noted.) (Notes 1–5)

PARAMETER	SYMBOL	CONDITIONS	-40°C			+25°C			+85°C			UNITS
			MIN	TYP	MAX	MIN	TYP	MAX	MIN	TYP	MAX	
<b>DIFFERENTIAL INPUT (D, <math>\bar{D}</math>)</b>												
Single-Ended Input High Voltage	V <sub>IH</sub>	V <sub>BB</sub> connected to $\bar{D}$ (V <sub>IL</sub> for V <sub>BB</sub> connected to D), Figure 1	V <sub>CC</sub> - 1.210		V <sub>CC</sub>	V <sub>CC</sub> - 1.145		V <sub>CC</sub>	V <sub>CC</sub> - 1.085		V <sub>CC</sub>	V
Single-Ended Input Low Voltage	V <sub>IL</sub>	V <sub>BB</sub> connected to $\bar{D}$ (V <sub>IH</sub> for V <sub>BB</sub> connected to D), Figure 1	V <sub>EE</sub>		V <sub>CC</sub> - 1.65	V <sub>EE</sub>		V <sub>CC</sub> - 1.545	V <sub>EE</sub>		V <sub>CC</sub> - 1.485	V
High Voltage of Differential Input	V <sub>IHD</sub>		V <sub>EE</sub> + 1.2		V <sub>CC</sub>	V <sub>EE</sub> + 1.2		V <sub>CC</sub>	V <sub>EE</sub> + 1.2		V <sub>CC</sub>	V
Low Voltage of Differential Input	V <sub>ILD</sub>		V <sub>EE</sub>		V <sub>CC</sub> - 0.1	V <sub>EE</sub>		V <sub>CC</sub> - 0.1	V <sub>EE</sub>		V <sub>CC</sub> - 0.1	V
Differential Input Voltage	V <sub>IHD</sub> - V <sub>ILD</sub>	For V <sub>CC</sub> - V <sub>EE</sub> < 3.0V	0.1		V <sub>CC</sub> - V <sub>EE</sub>	0.1		V <sub>CC</sub> - V <sub>EE</sub>	0.1		V <sub>CC</sub> - V <sub>EE</sub>	V
		For V <sub>CC</sub> - V <sub>EE</sub> ≥ 3.0V	0.1		3.0	0.1		3.0	0.1		3.0	
Input High Current	I <sub>IH</sub>				150			150			150	$\mu$ A
D Input Low Current	I <sub>ILD</sub>		-10		100	-10		100	-10		100	$\mu$ A
$\bar{D}$ Input Low Current	I <sub>IL<math>\bar{D}</math></sub>		-150		+150	-150		+150	-150		+150	$\mu$ A

# Differential LVPECL/LVECL/HSTL Receiver/Drivers

MAX9321/MAX9321A

## DC ELECTRICAL CHARACTERISTICS (continued)

( $V_{CC} - V_{EE} = +2.25V$  to  $+3.8V$ , outputs loaded with  $50\Omega \pm 1\%$  to  $V_{CC} - 2.0V$ . Typical values are at  $V_{CC} - V_{EE} = +3.3V$ ,  $V_{IHD} = V_{CC} - 1V$ ,  $V_{ILD} = V_{CC} - 1.5V$ , unless otherwise noted.) (Notes 1–5)

PARAMETER	SYMBOL	CONDITIONS	-40°C			+25°C			+85°C			UNITS
			MIN	TYP	MAX	MIN	TYP	MAX	MIN	TYP	MAX	
<b>DIFFERENTIAL OUTPUT (Q, <math>\bar{Q}</math>)</b>												
Single-Ended Output High Voltage	$V_{OH}$	Figure 1	$V_{CC} - 1.135$	$V_{CC} - 0.885$	$V_{CC} - 1.07$	$V_{CC} - 0.82$	$V_{CC} - 1.01$	$V_{CC} - 0.76$			V	
Single-Ended Output Low Voltage	$V_{OL}$	Figure 1	$V_{CC} - 1.935$	$V_{CC} - 1.685$	$V_{CC} - 1.87$	$V_{CC} - 1.62$	$V_{CC} - 1.81$	$V_{CC} - 1.56$			V	
Differential Output Voltage	$V_{OH} - V_{OL}$	Figure 1	550		550		550				mV	
<b>REFERENCE (<math>V_{BB}</math>)</b>												
Reference Voltage Output (Note 6)	$V_{BB}$	$I_{BB} = \pm 0.5mA$	$V_{CC} - 1.55$	$V_{CC} - 1.31$	$V_{CC} - 1.445$	$V_{CC} - 1.245$	$V_{CC} - 1.385$	$V_{CC} - 1.185$			V	
<b>POWER SUPPLY</b>												
Supply Current (Note 7)	$I_{EE}$		16	24	17	24	18	24			mA	

## AC ELECTRICAL CHARACTERISTICS

( $V_{CC} - V_{EE} = +2.25V$  to  $+3.8V$ , outputs loaded with  $50\Omega \pm 1\%$  to  $V_{CC} - 2V$ , input frequency =  $1.5GHz$ , input transition time =  $125ps$  (20% to 80%),  $V_{IHD} = V_{EE} + 1.2V$  to  $V_{CC}$ ,  $V_{ILD} = V_{EE}$  to  $V_{CC} - 0.15V$ ,  $V_{IHD} - V_{ILD} = 0.15V$  to the smaller of  $3V$  or  $V_{CC} - V_{EE}$ . Typical values are at  $V_{CC} - V_{EE} = 3.3V$ ,  $V_{IHD} = V_{CC} - 1V$ ,  $V_{ILD} = V_{CC} - 1.5V$ , unless otherwise noted.) (Notes 8, 11)

PARAMETER	SYMBOL	CONDITIONS	-40°C			+25°C			+85°C			UNITS
			MIN	TYP	MAX	MIN	TYP	MAX	MIN	TYP	MAX	
Differential Input-to-Output Delay	$t_{PLHD}$ , $t_{PHLD}$	Figure 2	145	184	235	145	172	245	130	167	230	ps
Part-to-Part Skew (Note 9)	$t_{SKPP}$			25	90		20	100		20	100	ps
Added Random Jitter (Note 10)	$t_{RJ}$	$f_{IN} = 1.5GHz$ , Clock pattern		1.7	2.8		1.7	2.8		1.7	2.8	ps (RMS)
		$f_{IN} = 3.0GHz$ , Clock pattern		0.6	1.5		0.6	1.5		0.6	1.5	

# Differential LVPECL/LVECL/HSTL Receiver/Drivers

## AC ELECTRICAL CHARACTERISTICS (continued)

( $V_{CC} - V_{EE} = +2.25V$  to  $+3.8V$ , outputs loaded with  $50\Omega \pm 1\%$  to  $V_{CC} - 2V$ , input frequency =  $1.5GHz$ , input transition time =  $125ps$  (20% to 80%),  $V_{IHD} = V_{EE} + 1.2V$  to  $V_{CC}$ ,  $V_{ILD} = V_{EE}$  to  $V_{CC} - 0.15V$ ,  $V_{IHD} - V_{ILD} = 0.15V$  to the smaller of  $3V$  or  $V_{CC} - V_{EE}$ . Typical values are at  $V_{CC} - V_{EE} = 3.3V$ ,  $V_{IHD} = V_{CC} - 1V$ ,  $V_{ILD} = V_{CC} - 1.5V$ , unless otherwise noted.) (Notes 8, 11)

PARAMETER	SYMBOL	CONDITIONS	-40°C			+25°C			+85°C			UNITS
			MIN	TYP	MAX	MIN	TYP	MAX	MIN	TYP	MAX	
Added Deterministic Jitter (Note 10)	$t_{DJ}$	3.0Gbps 2 <sup>23</sup> -1 PRBS pattern		57	80		57	80		57	80	ps (p-p)
Switching Frequency	$f_{MAX}$	$V_{OH} - V_{OL} \geq 300mV$ , Clock pattern, Figure 2	3.0			3.0			3.0			GHz
		$V_{OH} - V_{OL} \geq 550mV$ , Clock pattern, Figure 2	2.0			2.0			2.0			
Output Rise/ Fall Time (20% to 80%)	$t_R, t_F$	Figure 2	50	88	120	50	89	120	50	90	120	ps

**Note 1:** Guaranteed by design and characterization.

**Note 2:** Measurements are made with the device in thermal equilibrium.

**Note 3:** Current into a pin is defined as positive. Current out of a pin is defined as negative.

**Note 4:** DC parameters production tested at  $T_A = +25^\circ C$ . Guaranteed by design and characterization over the full operating temperature range.

**Note 5:** Single-ended input operation is limited to  $V_{CC} - V_{EE} \geq 3.0V$ .

**Note 6:** Use  $V_{BB}$  as a reference for inputs on the same device only.

**Note 7:** All pins open except  $V_{CC}$  and  $V_{EE}$ .

**Note 8:** Guaranteed by design and characterization. Limits are set at  $\pm 6$  sigma.

**Note 9:** Measured between outputs of different parts at the signal crossing points under identical conditions for a same-edge transition.

**Note 10:** Device jitter added to the input signal.

# Differential LVPECL/LVECL/HSTL Receiver/Drivers

## Typical Operating Characteristics

(SO packages) ( $V_{CC} = +3.3V$ ,  $V_{EE} = 0$ , input transition time = 125ps (20% to 80%),  $V_{IHD} = V_{CC} - 1V$ ,  $V_{ILD} = V_{CC} - 1.5V$ ,  $f_{IN} = 1.5GHz$ , outputs loaded with  $50\Omega$  to  $V_{CC} - 2V$ ,  $T_A = +25^\circ C$ , unless otherwise noted.)

**MAX9321/MAX9321A**

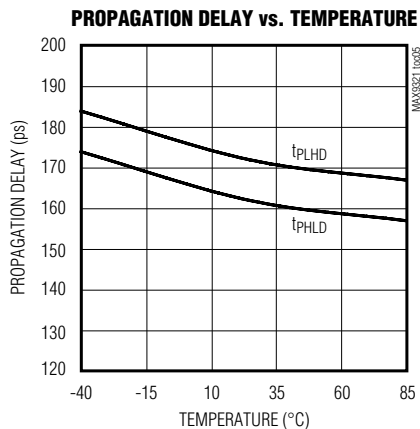
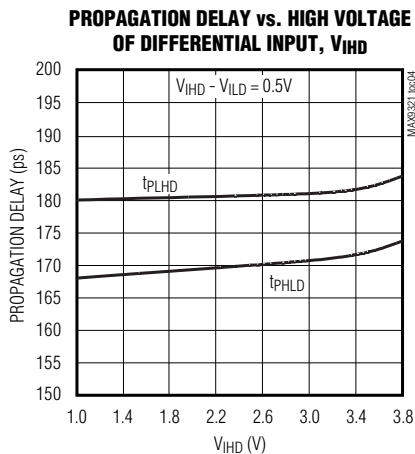
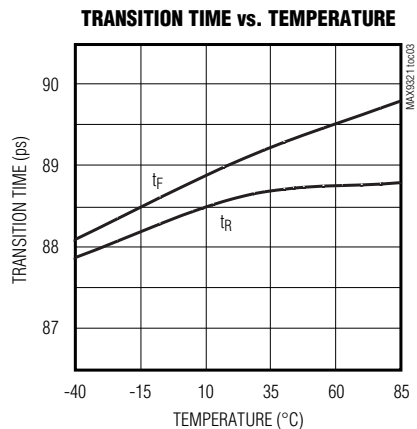
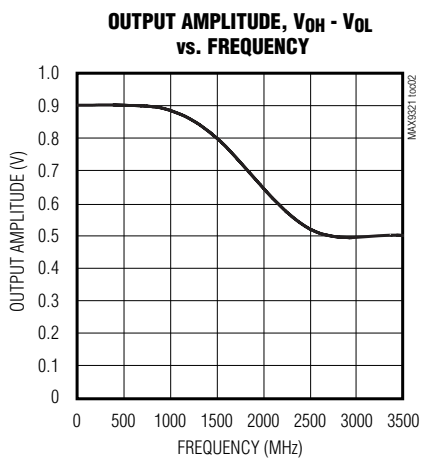
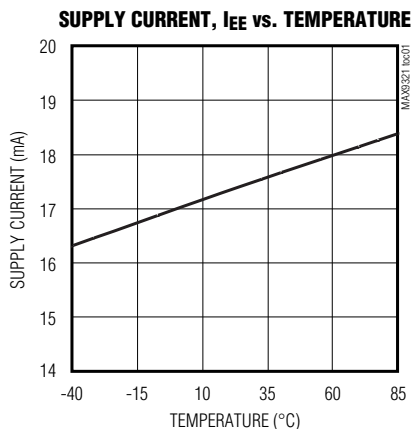

# Differential LVPECL/LVECL/HSTL Receiver/Drivers

## Pin Description (MAX9321)

PIN		NAME	FUNCTION
$\mu$ MAX/SO	SOT23		
1	6	N.C.	No Connection
2	3	D	Noninverting Differential Input. 100k $\Omega$ pulldown to V <sub>EE</sub> .
3	4	$\bar{D}$	Inverting Differential Input. 60k $\Omega$ pullup to V <sub>CC</sub> and 100k $\Omega$ pulldown to V <sub>EE</sub> .
4	5	V <sub>BB</sub>	Reference Output Voltage. Connect to the inverting or noninverting input to provide a reference for single-ended operation. When used, bypass with a 0.01 $\mu$ F ceramic capacitor to V <sub>CC</sub> ; otherwise leave open.
5	2	V <sub>EE</sub>	Negative Supply Voltage
6	7	$\bar{Q}$	Inverting Output. Typically terminate with 50 $\Omega$ resistor to V <sub>CC</sub> - 2V.
7	8	Q	Noninverting Output. Typically terminate with 50 $\Omega$ resistor to V <sub>CC</sub> - 2V.
8	1	V <sub>CC</sub>	Positive Supply Voltage. Bypass from V <sub>CC</sub> to V <sub>EE</sub> with 0.1 $\mu$ F and 0.01 $\mu$ F ceramic capacitors. Place the capacitors as close to the device as possible with the smaller value capacitor closest to the device.

## Pin Description (MAX9321A)

PIN		NAME	FUNCTION
$\mu$ MAX/SO	SOT23		
1	6	N.C.	No Connection
2	3	$\bar{D}$	Inverting Differential Input. 60k $\Omega$ pullup to V <sub>CC</sub> and 100k $\Omega$ pulldown to V <sub>EE</sub> .
3	4	D	Noninverting Differential Input. 100k $\Omega$ pulldown to V <sub>EE</sub> .
4	5	V <sub>BB</sub>	Reference Output Voltage. Connect to the inverting or noninverting input to provide a reference for single-ended operation. When used, bypass with a 0.01 $\mu$ F ceramic capacitor to V <sub>CC</sub> ; otherwise leave open.
5	2	V <sub>EE</sub>	Negative Supply Voltage
6	8	Q	Noninverting Output. Typically terminate with 50 $\Omega$ resistor to V <sub>CC</sub> - 2V.
7	7	$\bar{Q}$	Inverting Output. Typically terminate with 50 $\Omega$ resistor to V <sub>CC</sub> - 2V.
8	1	V <sub>CC</sub>	Positive Supply Voltage. Bypass from V <sub>CC</sub> to V <sub>EE</sub> with 0.1 $\mu$ F and 0.01 $\mu$ F ceramic capacitors. Place the capacitors as close to the device as possible with the smaller value capacitor closest to the device.

# Differential LVPECL/LVECL/HSTL Receiver/Drivers

MAX9321/MAX9321A

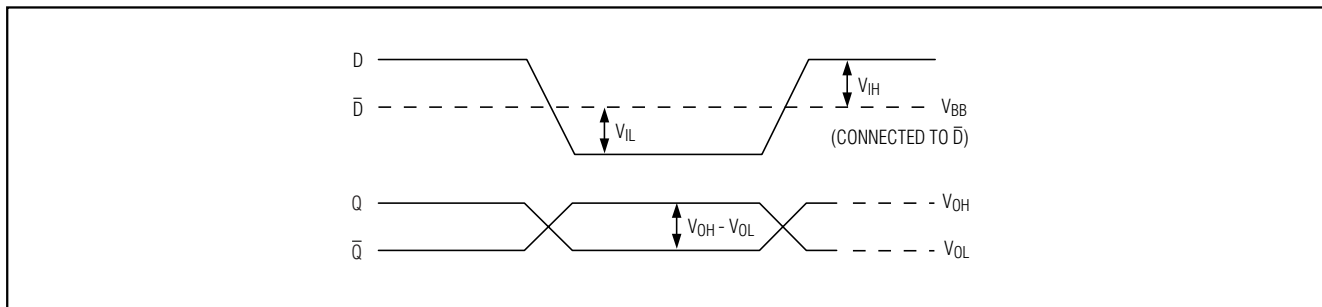

Figure 1. Switching with Single-Ended Input

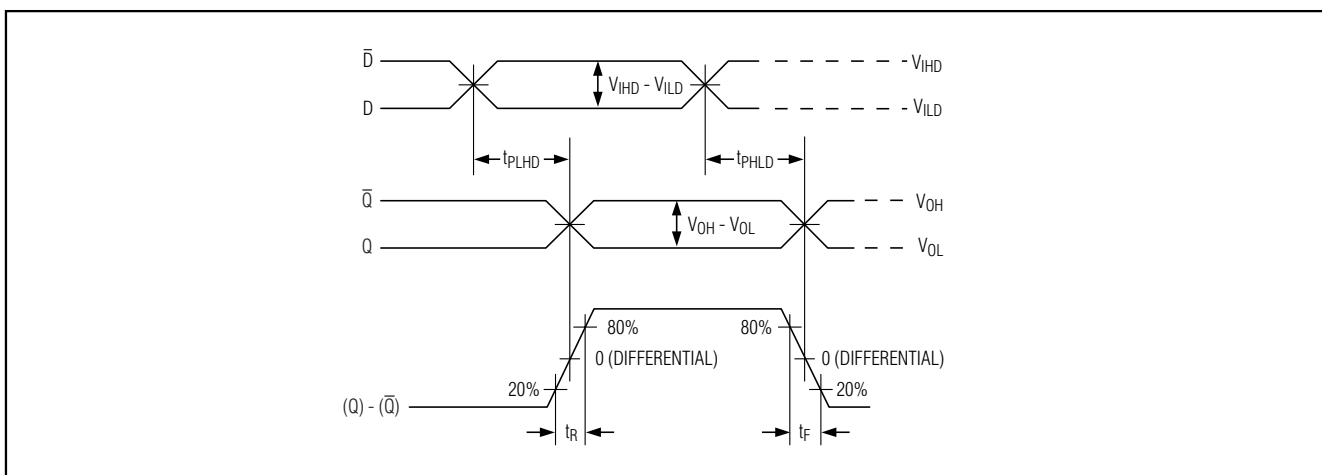

Figure 2. Differential Transition Time and Propagation Delay Timing Diagram

## Detailed Description

The MAX9321/MAX9321A are low-skew differential receiver/drivers designed for clock and data distribution. For interfacing to differential HSTL and LVPECL signals, these devices operate over a +2.25V to +3.8V supply range, allowing high-performance clock and data distribution in systems with a nominal +2.5V or +3.3V supply. For differential LVECL operation, these devices operate from a -2.25V to -3.8V supply.

## Inputs

The differential input can be configured to accept a single-ended input when operating at approximately  $V_{CC} - V_{EE} = 3.0V$  to  $3.8V$ . This is accomplished by connecting the on-chip reference voltage,  $V_{BB}$ , to an input as a reference. For example, the differential  $D$ ,  $\bar{D}$  input is converted to a noninverting, single-ended input by connecting  $V_{BB}$  to  $\bar{D}$  and connecting the single-ended input to  $D$ . An inverting input is obtained by connecting

$V_{BB}$  to  $D$  and connecting the single-ended input to  $\bar{D}$ . With the differential input configured as single ended (using  $V_{BB}$ ), the single-ended input can be driven to  $V_{CC}$  and  $V_{EE}$  or with a single-ended LVPECL/LVECL signal.

When the differential input is configured as a single-ended input (using  $V_{BB}$ ), the approximate supply range is  $V_{CC} - V_{EE} = 3.0V$  to  $3.8V$ . This is because one of the inputs must be  $V_{EE} + 1.2V$  or higher for proper operation of the input stage.  $V_{BB}$  must be at least  $V_{EE} + 1.2V$  because it becomes the high-level input when the other (single-ended) input swings below it. Therefore, minimum  $V_{BB} = V_{EE} + 1.2V$ .

The minimum  $V_{BB}$  output is  $V_{CC} - 1.510V$ . Substituting the minimum  $V_{BB}$  into  $V_{BB} = V_{EE} + 1.2V$  results in a minimum supply of  $2.71V$ . Rounding up to a standard supply gives the single-ended operating supply range of  $V_{CC} - V_{EE} = 3.0V$  to  $3.8V$ .

## Differential LVPECL/LVECL/HSTL Receiver/Drivers

When using the  $V_{BB}$  reference output, bypass it with a  $0.01\mu\text{F}$  ceramic capacitor to  $V_{CC}$ . If the  $V_{BB}$  reference is not used, it can be left open. The  $V_{BB}$  reference can source or sink  $0.5\text{mA}$ . Use  $V_{BB}$  only for an input on the same device as the  $V_{BB}$  reference.

The maximum magnitude of the differential input from  $D$  to  $\bar{D}$  is  $3.0\text{V}$  or  $V_{CC} - V_{EE}$ , whichever is less. This limit also applies to the difference between any reference voltage input and a single-ended input.

The differential input has bias resistors that drive the output to a differential low when the inputs are open. The inverting input is biased with a  $60\text{k}\Omega$  pullup to  $V_{CC}$  and a  $100\text{k}\Omega$  pulldown to  $V_{EE}$ . The noninverting input is biased with a  $100\text{k}\Omega$  pulldown to  $V_{EE}$ .

Specifications for the high and low voltage of the differential input ( $V_{IHD}$  and  $V_{ILD}$ ) and the differential input voltage ( $V_{IHD} - V_{ILD}$ ) apply simultaneously ( $V_{ILD}$  cannot be higher than  $V_{IHD}$ ).

### Outputs

Output levels are referenced to  $V_{CC}$  and are considered LVPECL or LVECL, depending on the level of the  $V_{CC}$  supply. With  $V_{CC}$  connected to a positive supply and  $V_{EE}$  connected to GND, the output is LVPECL. The output is LVECL when  $V_{CC}$  is connected to GND and  $V_{EE}$  is connected to a negative supply.

A single-ended input of at least  $V_{BB} \pm 100\text{mV}$  or a differential input of at least  $\pm 100\text{mV}$  switches the outputs to the  $V_{OH}$  and  $V_{OL}$  levels specified in the *DC Electrical Characteristics* table.

## Applications Information

### Supply Bypassing

Bypass  $V_{CC}$  to  $V_{EE}$  with high-frequency surface-mount ceramic  $0.1\mu\text{F}$  and  $0.01\mu\text{F}$  capacitors in parallel as close to the device as possible, with the  $0.01\mu\text{F}$  value

capacitor closest to the device. Use multiple parallel vias for low inductance. When using the  $V_{BB}$  reference output, bypass it with a  $0.01\mu\text{F}$  ceramic capacitor to  $V_{CC}$  (if the  $V_{BB}$  reference is not used, it can be left open).

### Traces

Input and output trace characteristics affect the performance of the MAX9321/MAX9321A. Connect each signal of a differential input or output to a  $50\Omega$  characteristic impedance trace. Minimize the number of vias to prevent impedance discontinuities. Reduce reflections by maintaining the  $50\Omega$  characteristic impedance through connectors and across cables. Reduce skew within a differential pair by matching the electrical length of the traces.

The exposed-pad (EP) SO package can be soldered to the PC board for enhanced thermal performance. If the EP is not soldered to the PC board, the thermal resistance is the same as the regular SO package. The EP is connected to the chip  $V_{EE}$  supply. Be sure that the pad does not touch signal lines or other supplies.

Contact Maxim's Packaging department for guidelines on the use of EP packages.

### Output Termination

Terminate outputs through  $50\Omega$  to  $V_{CC} - 2\text{V}$  or use an equivalent Thevenin termination. When a single-ended signal is taken from the differential output, terminate both outputs. For example, when  $Q$  is used as a single-ended output, terminate both  $Q$  and  $\bar{Q}$ .

## Chip Information

TRANSISTOR COUNT: 162

## Pin Configurations (continued)

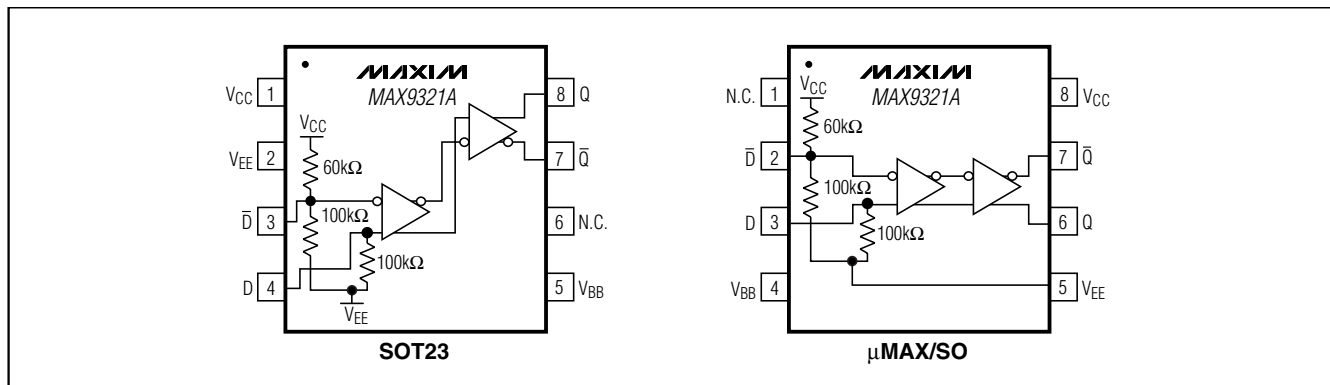



# Differential LVPECL/LVECL/HSTL Receiver/Drivers

## Package Information

(The package drawing(s) in this data sheet may not reflect the most current specifications. For the latest package outline information, go to [www.maxim-ic.com/packages](http://www.maxim-ic.com/packages).)

MAX9321/MAX9321A

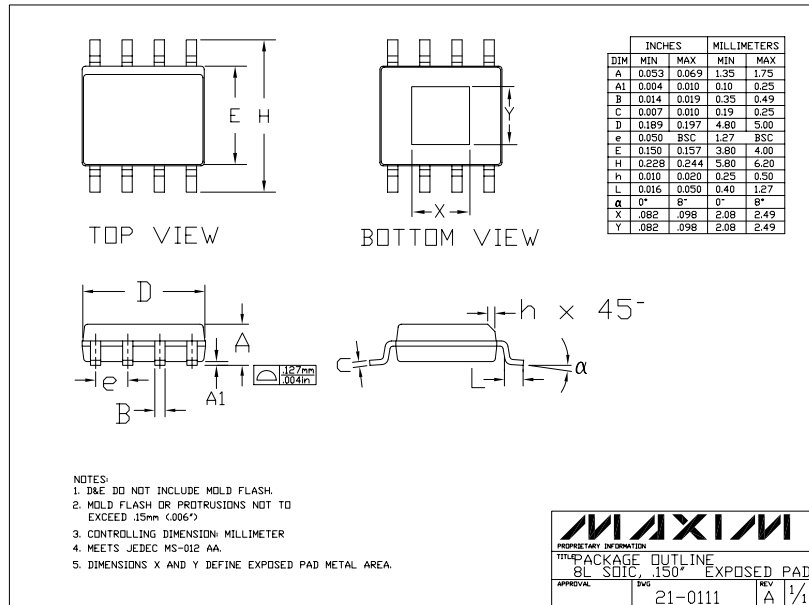
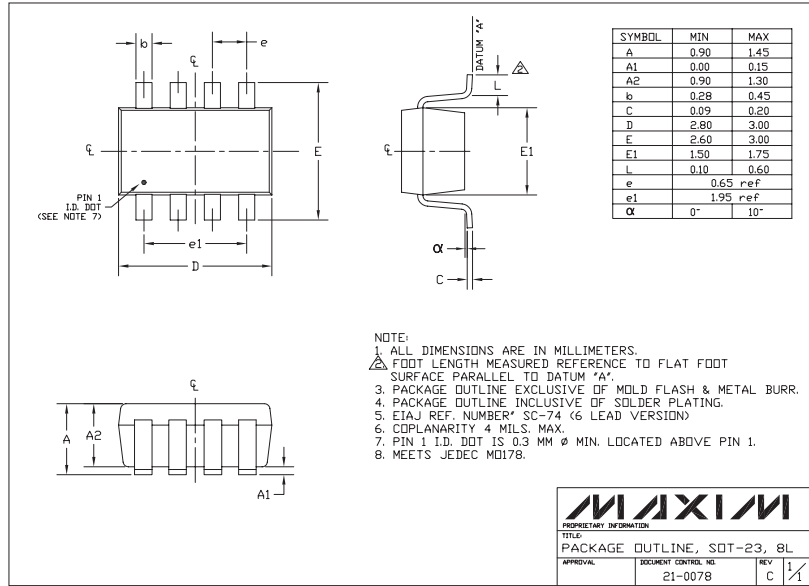

Maxim cannot assume responsibility for use of any circuitry other than circuitry entirely embodied in a Maxim product. No circuit patent licenses are implied. Maxim reserves the right to change the circuitry and specifications without notice at any time.

Maxim Integrated Products, 120 San Gabriel Drive, Sunnyvale, CA 94086 408-737-7600 9

Компания «Океан Электроники» предлагает заключение долгосрочных отношений при поставках импортных электронных компонентов на взаимовыгодных условиях!

Наши преимущества:

- Поставка оригинальных импортных электронных компонентов напрямую с производств Америки, Европы и Азии, а так же с крупнейших складов мира;
- Широкая линейка поставок активных и пассивных импортных электронных компонентов (более 30 млн. наименований);
- Поставка сложных, дефицитных, либо снятых с производства позиций;
- Оперативные сроки поставки под заказ (от 5 рабочих дней);
- Экспресс доставка в любую точку России;
- Помощь Конструкторского Отдела и консультации квалифицированных инженеров;
- Техническая поддержка проекта, помощь в подборе аналогов, поставка прототипов;
- Поставка электронных компонентов под контролем ВП;
- Система менеджмента качества сертифицирована по Международному стандарту ISO 9001;
- При необходимости вся продукция военного и аэрокосмического назначения проходит испытания и сертификацию в лаборатории (по согласованию с заказчиком);
- Поставка специализированных компонентов военного и аэрокосмического уровня качества (Xilinx, Altera, Analog Devices, Intersil, Interpoint, Microsemi, Actel, Aeroflex, Peregrine, VPT, Syfer, Eurofarad, Texas Instruments, MS Kennedy, Miteq, Cobham, E2V, MA-COM, Hittite, Mini-Circuits, General Dynamics и др.);

Компания «Океан Электроники» является официальным дистрибьютором и эксклюзивным представителем в России одного из крупнейших производителей разъемов военного и аэрокосмического назначения «JONHON», а так же официальным дистрибьютором и эксклюзивным представителем в России производителя высокотехнологичных и надежных решений для передачи СВЧ сигналов «FORSTAR».



## JONHON

«JONHON» (основан в 1970 г.)

Разъемы специального, военного и аэрокосмического назначения:

(Применяются в военной, авиационной, аэрокосмической, морской, железнодорожной, горно- и нефтедобывающей отраслях промышленности)

«FORSTAR» (основан в 1998 г.)

ВЧ соединители, коаксиальные кабели, кабельные сборки и микроволновые компоненты:

(Применяются в телекоммуникациях гражданского и специального назначения, в средствах связи, РЛС, а так же военной, авиационной и аэрокосмической отраслях промышленности).



Телефон: 8 (812) 309-75-97 (многоканальный)

Факс: 8 (812) 320-03-32

Электронная почта: [ocean@oceanchips.ru](mailto:ocean@oceanchips.ru)

Web: <http://oceanchips.ru/>

Адрес: 198099, г. Санкт-Петербург, ул. Калинина, д. 2, корп. 4, лит. А