

# LM2903, LM393/LM393A, LM293A

## Dual Differential Comparator

### Features

- Single Supply Operation: 2V to 36V
- Dual Supply Operation:  $\pm 1V$  to  $\pm 18V$
- Allow Comparison of Voltages Near Ground Potential
- Low Current Drain 800 $\mu A$  Typ.
- Compatible with all Forms of Logic
- Low Input Bias Current 25nA Typ.
- Low Input Offset Current  $\pm 5nA$  Typ.
- Low Offset Voltage  $\pm 1mV$  Typ.

### Description

The LM2903, LM393/LM393A, LM293A consist of two independent voltage comparators designed to operate from a single power supply over a wide voltage range.

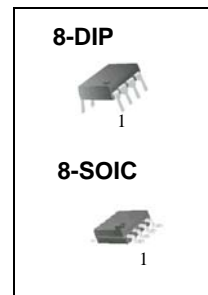

### Internal Block Diagram

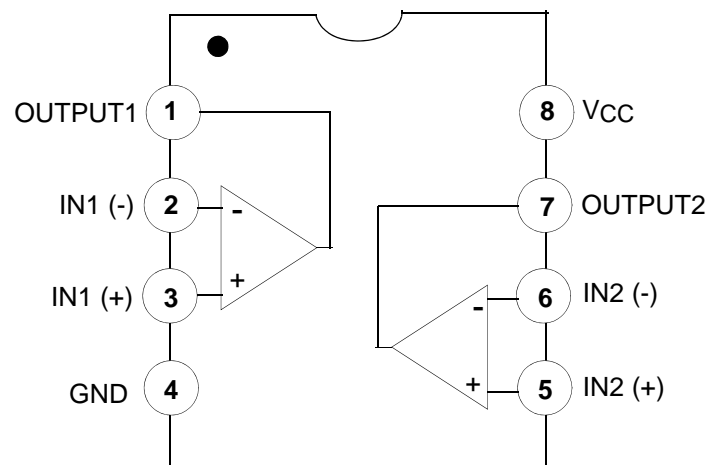

## Schematic Diagram

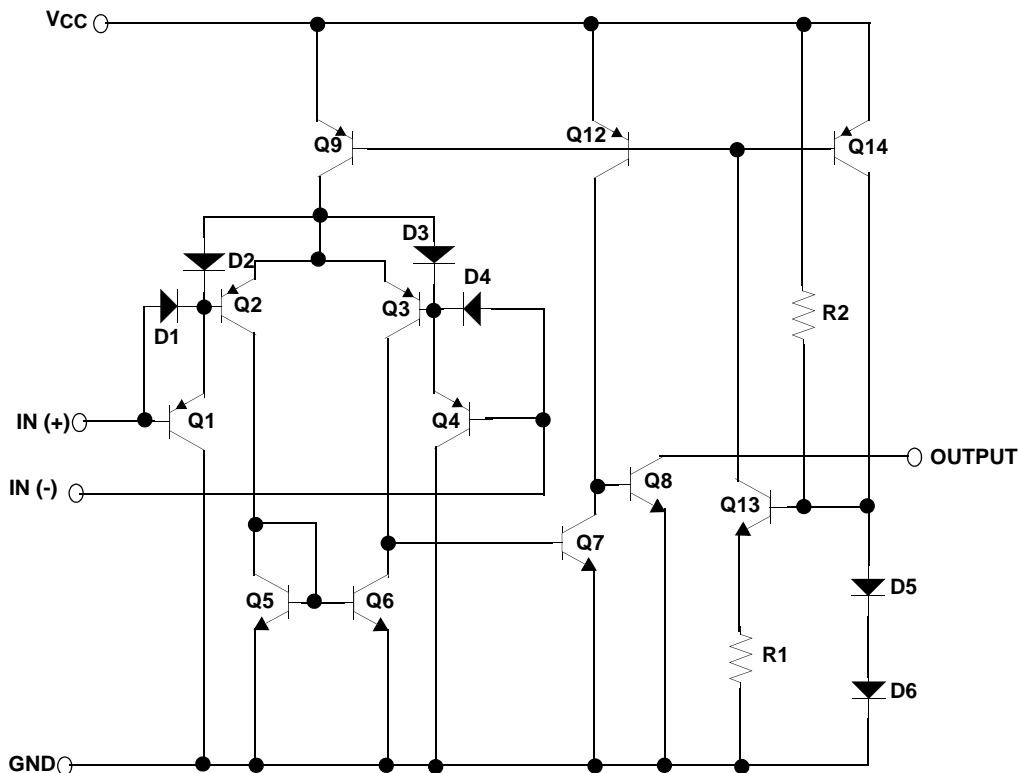

## Absolute Maximum Ratings

Parameter	Symbol	Value	Unit
Power Supply Voltage	VCC	±18 or 36	V
Differential Input Voltage	VI(DIFF)	36	V
Input Voltage	VI	-0.3 to +36	V
Output Short Circuit to GND	-	Continuous	-
Power Dissipation, Ta = 25°C 8-DIP 8-SOIC	PD	1040 480	mW
Operating Temperature LM393/LM393A LM2903 LM293A	TOPR	0 ~ +70 -40 ~ +105 -25 ~ +85	°C
Storage Temperature	TSTG	-65 ~ +150	°C

## Thermal Data

Parameter	Symbol	Value	Unit
Thermal Resistance Junction-Ambient Max. 8-DIP 8-SOIC	Rθja	120 260	°C/W

## Electrical Characteristics

( $V_{CC} = 5V$ ,  $T_A = 25^\circ C$ , unless otherwise specified)

Parameter	Symbol	Conditions	LM293A/LM393A			LM393			Unit
			Min.	Typ.	Max.	Min.	Typ.	Max.	
Input Offset Voltage	$V_{IO}$	$V_{O(P)} = 1.4V$ , $R_S = 0\Omega$	-	$\pm 1$	$\pm 2$	-	$\pm 1$	$\pm 5$	mV
		$V_{CM} = 0$ to $1.5V$   Note1	-	-	$\pm 4.0$	-	-	$\pm 9.0$	
Input Offset Current	$I_{IO}$		-	$\pm 5$	$\pm 50$	-	$\pm 5$	$\pm 50$	nA
		Note1	-	-	$\pm 150$	-	-	$\pm 150$	
Input Bias Current	$I_{BIAS}$		-	65	250	-	65	250	nA
		Note1	-	-	400	-	-	400	
Input Common Mode Voltage Range	$V_{I(R)}$		0	-	$V_{CC} - 1.5$	0	-	$V_{CC} - 1.5$	V
		Note1	0	-	$V_{CC} - 2$	0	-	$V_{CC} - 2$	
Supply Current	$I_{CC}$	$R_L = \infty$ , $V_{CC} = 5V$	-	0.6	1	-	0.6	1	mA
		$R_L = \infty$ , $V_{CC} = 30V$	-	0.8	2.5	-	0.8	2.5	
Voltage Gain	$G_V$	$V_{CC} = 15V$ , $R_L \geq 15k\Omega$ (for large $V_{O(P-P)}$ swing)	50	200	-	50	200	-	V/mV
Large Signal Response Time	$T_{LRES}$	$V_I = \text{TTL Logic Swing}$ $V_{REF} = 1.4V$ , $V_{RL} = 5V$ , $R_L = 5.1k\Omega$	-	350	-	-	350	-	nS
Response Time	$T_{RES}$	$V_{RL} = 5V$ , $R_L = 5.1k\Omega$	-	1.4	-	-	1.4	-	$\mu S$
Output Sink Current	$I_{SINK}$	$V_{I(-)} \geq 1V$ , $V_{I(+)} = 0V$ , $V_{O(P)} \leq 1.5V$	6	18	-	6	18	-	mA
Output Saturation Voltage	$V_{SAT}$	$V_{I(-)} \geq 1V$ , $V_{I(+)} = 0V$	-	160	400	-	160	400	mV
		$I_{SINK} = 4mA$   Note1	-	-	700	-	-	700	
Output Leakage Current	$I_{O(LKG)}$	$V_{I(-)} = 0V$ , $V_{I(+)} = 1V$		$V_{O(P)} = 5V$	-	0.1	-	0.1	nA
				$V_{O(P)} = 30V$	-	-	1.0	-	1.0

### Note1

LM393/LM393A:  $0 \leq T_A \leq +70^\circ C$

LM2903:  $-40 \leq T_A \leq +105^\circ C$

LM293A :  $-25 \leq T_A \leq +85^\circ C$

**Electrical Characteristics** (Continued)(V<sub>CC</sub> = 5V, T<sub>A</sub> = 25°C, unless otherwise specified)

Parameter	Symbol	Conditions	LM2903			Unit
			Min.	Typ.	Max.	
Input Offset Voltage	V <sub>IO</sub>	V <sub>O(P)</sub> = 1.4V, R <sub>S</sub> = 0Ω	-	±1	±7	mV
		V <sub>CM</sub> = 0 to 1.5V   Note1	-	±9	±15	
Input Offset Current	I <sub>IO</sub>		-	±5	±50	nA
		Note1	-	±50	±200	
Input Bias Current	I <sub>BIAS</sub>		-	65	250	nA
		Note1	-	-	500	
Input Common Mode Voltage Range	V <sub>I(R)</sub>		0	-	V <sub>CC</sub> - 1.5	V
		Note1	0	-	V <sub>CC</sub> - 2	
Supply Current	I <sub>CC</sub>	R <sub>L</sub> = ∞, V <sub>CC</sub> = 5V	-	0.6	1	mA
		R <sub>L</sub> = ∞, V <sub>CC</sub> = 30V	-	1	2.5	
Voltage Gain	GV	V <sub>CC</sub> = 15V, R <sub>L</sub> ≥ 15kΩ (for large V <sub>O(P-P)</sub> swing)	25	100	-	V/mV
Large Signal Response Time	T <sub>LR</sub>	V <sub>I</sub> = TTL Logic Swing V <sub>REF</sub> = 1.4V, V <sub>R</sub> = 5V, R <sub>L</sub> = 5.1kΩ	-	350	-	nS
Response Time	T <sub>R</sub>	V <sub>R</sub> = 5V, R <sub>L</sub> = 5.1kΩ	-	1.5	-	μS
Output Sink Current	I <sub>SINK</sub>	V <sub>I(-)</sub> ≥ 1V, V <sub>I(+)</sub> = 0V, V <sub>O(P)</sub> ≤ 1.5V	6	16	-	mA
Output Saturation Voltage	V <sub>SAT</sub>	V <sub>I(-)</sub> ≥ 1V, V <sub>I(+)</sub> = 0V	-	160	400	mV
		I <sub>SINK</sub> = 4mA   Note1	-	-	700	
Output Leakage Current	I <sub>O(LKG)</sub>	V <sub>I(-)</sub> = 0V, V <sub>O(P)</sub> = 5V	-	0.1	-	nA
		V <sub>I(+)</sub> = 1V, V <sub>O(P)</sub> = 30V	-	-	1.0	μA

**Note1**LM393/LM393A: 0 ≤ T<sub>A</sub> ≤ +70°CLM2903: -40 ≤ T<sub>A</sub> ≤ +105°CLM293A : -25 ≤ T<sub>A</sub> ≤ +85°C

# Typical Performance Characteristics

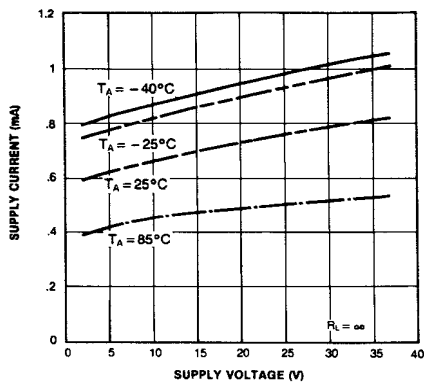

Figure 1. Supply Current vs Supply Voltage

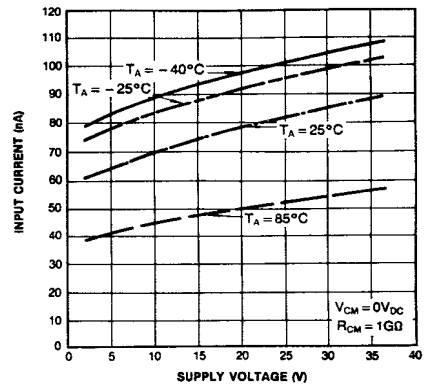

Figure 2. Input Current vs Supply Voltage

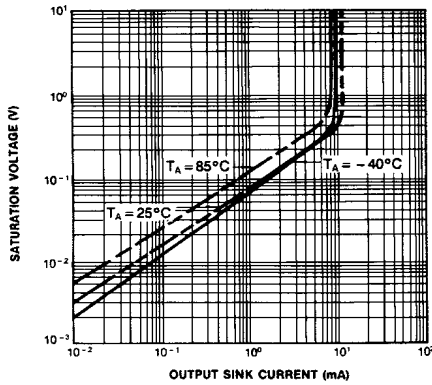

Figure 3. Output Saturation Voltage vs Sink Current

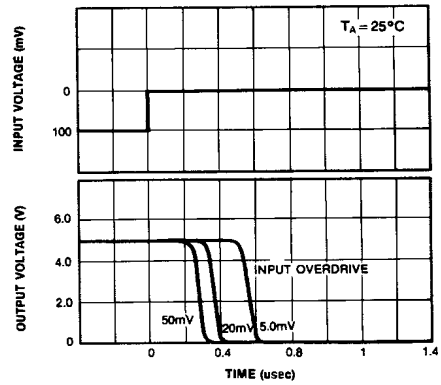

Figure 4. Response Time for Various Input Overdrive-Negative Transition

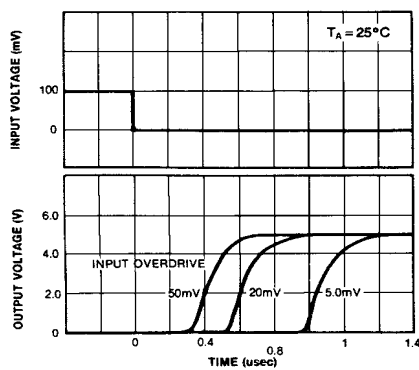

Figure 5. Response Time for Various Input Overdrive-Positive Transition

# Mechanical Dimensions

## Package

Dimensions in millimeters

### 8-DIP

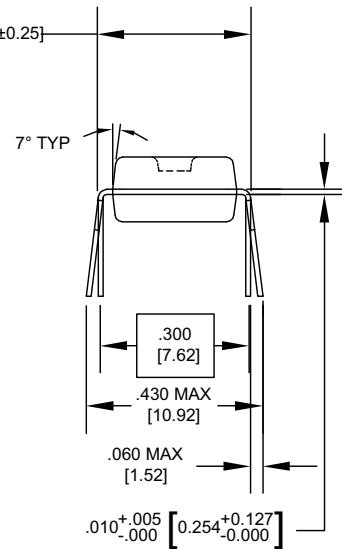
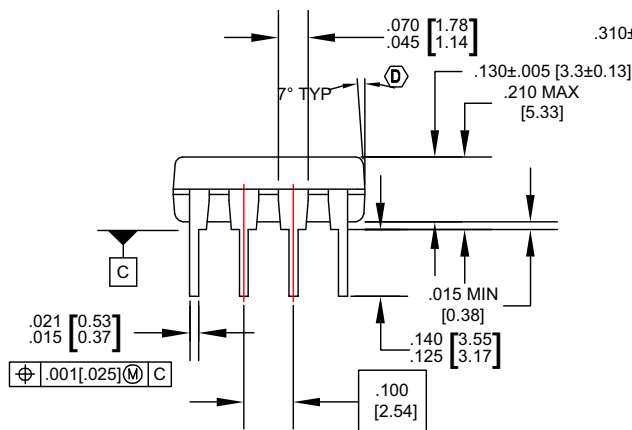
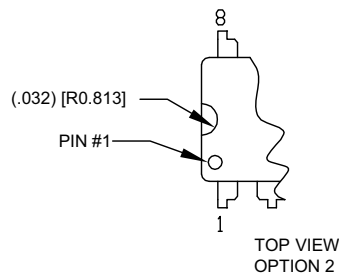
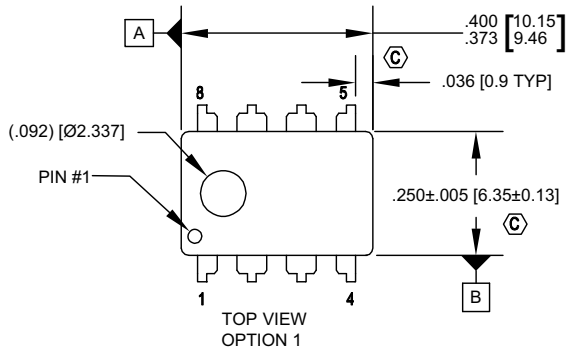

### NOTES:

- A. CONFORMS TO JEDEC REGISTRATION MS-001, VARIATIONS BA
- B. CONTROLLING DIMENSIONS ARE IN INCHES  
REFERENCE DIMENSIONS ARE IN MILLIMETERS
- C. DOES NOT INCLUDE MOLD FLASH OR PROTRUSIONS.  
MOLD FLASH OR PROTRUSIONS SHALL NOT EXCEED .010 INCHES OR 0.25MM.
- D. DOES NOT INCLUDE DAMBAR PROTRUSIONS.  
DAMBAR PROTRUSIONS SHALL NOT EXCEED .010 INCHES OR 0.25MM.
- E. DIMENSIONING AND TOLERANCING PER ASME Y14.5M-1994.

N08EREVG



## Ordering Information

Product Number	Operating Temperature	Package	Packing Method
LM393N	0 ~ +70°C	8-DIP	Rail
LM393AN			Rail
LM393M		8-SOIC	Rail
LM393MX			Tape & Reel
LM393AM			Rail
LM393AMX			Tape & Reel
LM2903N	-40 ~ +105°C	8-DIP	Rail
LM2903M		8-SOIC	Rail
LM2903MX			Tape & Reel
LM293AN	-25 ~ +85°C	8-DIP	Rail

### DISCLAIMER

FAIRCHILD SEMICONDUCTOR RESERVES THE RIGHT TO MAKE CHANGES WITHOUT FURTHER NOTICE TO ANY PRODUCTS HEREIN TO IMPROVE RELIABILITY, FUNCTION OR DESIGN. FAIRCHILD DOES NOT ASSUME ANY LIABILITY ARISING OUT OF THE APPLICATION OR USE OF ANY PRODUCT OR CIRCUIT DESCRIBED HEREIN; NEITHER DOES IT CONVEY ANY LICENSE UNDER ITS PATENT RIGHTS, NOR THE RIGHTS OF OTHERS.

### LIFE SUPPORT POLICY

FAIRCHILD'S PRODUCTS ARE NOT AUTHORIZED FOR USE AS CRITICAL COMPONENTS IN LIFE SUPPORT DEVICES OR SYSTEMS WITHOUT THE EXPRESS WRITTEN APPROVAL OF THE PRESIDENT OF FAIRCHILD SEMICONDUCTOR CORPORATION. As used herein:

1. Life support devices or systems are devices or systems which, (a) are intended for surgical implant into the body, or (b) support or sustain life, and (c) whose failure to perform when properly used in accordance with instructions for use provided in the labeling, can be reasonably expected to result in a significant injury of the user.
2. A critical component in any component of a life support device or system whose failure to perform can be reasonably expected to cause the failure of the life support device or system, or to affect its safety or effectiveness.



Компания «Океан Электроники» предлагает заключение долгосрочных отношений при поставках импортных электронных компонентов на взаимовыгодных условиях!

Наши преимущества:

- Поставка оригинальных импортных электронных компонентов напрямую с производств Америки, Европы и Азии, а так же с крупнейших складов мира;
- Широкая линейка поставок активных и пассивных импортных электронных компонентов (более 30 млн. наименований);
- Поставка сложных, дефицитных, либо снятых с производства позиций;
- Оперативные сроки поставки под заказ (от 5 рабочих дней);
- Экспресс доставка в любую точку России;
- Помощь Конструкторского Отдела и консультации квалифицированных инженеров;
- Техническая поддержка проекта, помощь в подборе аналогов, поставка прототипов;
- Поставка электронных компонентов под контролем ВП;
- Система менеджмента качества сертифицирована по Международному стандарту ISO 9001;
- При необходимости вся продукция военного и аэрокосмического назначения проходит испытания и сертификацию в лаборатории (по согласованию с заказчиком);
- Поставка специализированных компонентов военного и аэрокосмического уровня качества (Xilinx, Altera, Analog Devices, Intersil, Interpoint, Microsemi, Actel, Aeroflex, Peregrine, VPT, Syfer, Eurofarad, Texas Instruments, MS Kennedy, Miteq, Cobham, E2V, MA-COM, Hittite, Mini-Circuits, General Dynamics и др.);

Компания «Океан Электроники» является официальным дистрибьютором и эксклюзивным представителем в России одного из крупнейших производителей разъемов военного и аэрокосмического назначения «JONHON», а так же официальным дистрибьютором и эксклюзивным представителем в России производителя высокотехнологичных и надежных решений для передачи СВЧ сигналов «FORSTAR».



## JONHON

«JONHON» (основан в 1970 г.)

Разъемы специального, военного и аэрокосмического назначения:

(Применяются в военной, авиационной, аэрокосмической, морской, железнодорожной, горно- и нефтедобывающей отраслях промышленности)

«FORSTAR» (основан в 1998 г.)

ВЧ соединители, коаксиальные кабели, кабельные сборки и микроволновые компоненты:

(Применяются в телекоммуникациях гражданского и специального назначения, в средствах связи, РЛС, а так же военной, авиационной и аэрокосмической отраслях промышленности).



Телефон: 8 (812) 309-75-97 (многоканальный)

Факс: 8 (812) 320-03-32

Электронная почта: [ocean@oceanchips.ru](mailto:ocean@oceanchips.ru)

Web: <http://oceanchips.ru/>

Адрес: 198099, г. Санкт-Петербург, ул. Калинина, д. 2, корп. 4, лит. А