

nRF905

Single chip 433/868/915MHz Transceiver

Product Specification

Key Features

- True single chip GFSK transceiver in a small 32 pin package (32L QFN 5x5mm)
- ShockBurst™ mode for low power operation
- Power supply range 1.9 to 3.6 V
- Multi channel operation – ETSI/FCC Compatible
- Channel switching time <650µs
- Extremely low cost Bill of Material (BOM)
- No external SAW filter
- Adjustable output power up to 10dBm
- Carrier detect for "listen before transmit" protocols
- Data Ready signal when a valid data packet is received or transmitted
- Address Match for detection of incoming packet
- Automatic retransmission of data packet
- Automatic CRC and preamble generation
- Low supply current (TX), typical 9mA @ -10dBm output power
- Low supply current (RX), typical 12.5mA

Applications

- Wireless data communication
- Alarm and security system
- Home automation
- Remote control
- Surveillance
- Automotive
- Telemetry
- Keyless entry
- Toys

Liability disclaimer

Nordic Semiconductor ASA reserves the right to make changes without further notice to the product to improve reliability, function or design. Nordic Semiconductor ASA does not assume any liability arising out of the application or use of any product or circuits described herein.

All application information is advisory and does not form part of the specification.

Limiting values

Stress above one or more of the limiting values may cause permanent damage to the device. These are stress ratings only and operation of the device at these or at any other conditions above those given in the specifications are not implied. Exposure to limiting values for extended periods may affect device reliability.

Life support applications

These products are not designed for use in life support appliances, devices, or systems where malfunction of these products can reasonably be expected to result in personal injury. Nordic Semiconductor ASA customers using or selling these products for use in such applications do so at their own risk and agree to fully indemnify Nordic Semiconductor ASA for any damages resulting from such improper use or sale.

| Data sheet status | |
|-----------------------------------|---|
| Objective product specification | This product specification contains target specifications for product development. |
| Preliminary product specification | This product specification contains preliminary data; supplementary data may be published from Nordic Semiconductor ASA later. |
| Product specification | This product specification contains final product specifications. Nordic Semiconductor ASA reserves the right to make changes at any time without notice in order to improve design and supply the best possible product. |

Contact details

Visit www.nordicsemi.no for Nordic Semiconductor sales offices and distributors worldwide

Main office:

Otto Nielsens vei 12
7004 Trondheim
Phone: +47 72 89 89 00
Fax: +47 72 89 89 89
www.nordicsemi.no



Writing conventions

This product specification follows a set of typographic rules that makes the document consistent and easy to read. The following writing conventions are used:

- Commands, bit state conditions, and register names are written in *Courier*.
- Pin names and pin signal conditions are written in *Courier bold*.
- Cross references are [underlined and highlighted in blue](#).

Revision history

| Date | Version | Description |
|------------|---------|--|
| June 2006 | 1.4 | |
| April 2008 | 1.5 | <ul style="list-style-type: none">• Restructured layout in the new template• Updated package information• Added moisture sensitivity level to the absolute maximum ratings |

Attention!

Observe precaution for handling
Electrostatic Sensitive Device.



Datasheet order code: 051005nRF905

Contents

| | | |
|-----------|--|-----------|
| 1 | Introduction | 6 |
| 2 | Quick reference data..... | 7 |
| 3 | Block Diagram | 8 |
| 4 | Absolute maximum ratings | 9 |
| 5 | Electrical Specifications | 10 |
| 6 | Current Consumption | 13 |
| 7 | Pin information | 14 |
| 7.1 | Pin Assignment | 14 |
| 7.2 | Pin Functions | 15 |
| 8 | Modes of Operation | 16 |
| 8.1 | Active Modes | 16 |
| 8.2 | Power Saving Modes | 16 |
| 8.3 | nRF ShockBurst™ Mode | 16 |
| 8.4 | Typical ShockBurst™ TX | 16 |
| 8.5 | Typical ShockBurst™ RX..... | 18 |
| 8.6 | Power Down Mode | 19 |
| 8.7 | Standby Mode | 19 |
| 9 | Device Configuration | 20 |
| 9.1 | SPI Register Configuration..... | 20 |
| 9.2 | SPI Instruction Set | 21 |
| 9.3 | SPI Timing..... | 21 |
| 9.4 | RF – Configuration Register Description..... | 23 |
| 9.5 | Register Contents | 24 |
| 10 | Important Timing Data | 26 |
| 10.1 | Device Switching Times | 26 |
| 10.2 | ShockBurst™ TX timing | 26 |
| 10.3 | ShockBurst™ RX timing..... | 27 |
| 10.4 | Preamble..... | 27 |
| 10.5 | Time On Air | 27 |
| 11 | Peripheral RF Information | 28 |
| 11.1 | Crystal Specification..... | 28 |
| 11.2 | External Clock Reference | 28 |
| 11.3 | Microprocessor Output Clock..... | 28 |
| 11.4 | Antenna Output | 29 |
| 11.5 | Output Power Adjustment | 29 |
| 11.6 | Modulation | 29 |
| 11.7 | Output Frequency | 29 |
| 11.8 | PCB Layout and Decoupling Guidelines | 30 |
| 12 | nRF905 features | 31 |
| 12.1 | Carrier Detect..... | 31 |
| 12.2 | Address Match | 31 |
| 12.3 | Data Ready | 31 |
| 12.4 | Auto Retransmit | 31 |
| 12.5 | RX Reduced Power Mode..... | 32 |
| 13 | Mechanical specifications | 33 |

| | | |
|-----------|--|-----------|
| 14 | Ordering information | 34 |
| 14.1 | Package marking..... | 34 |
| 14.1.1 | Abbreviations | 34 |
| 14.2 | Product options..... | 34 |
| 14.2.1 | RF silicon | 34 |
| 14.2.2 | Development tools | 34 |
| 15 | Application Examples | 35 |
| 15.1 | Differential Connection to a Loop Antenna..... | 35 |
| 15.2 | PCB Layout Example; Differential Connection to a Loop Antenna..... | 36 |
| 15.3 | Single ended connection to 50W antenna..... | 37 |
| 15.4 | PCB Layout Example; Single Ended Connection to 50W Antenna | 40 |
| 16 | Glossary of terms | 41 |

1 Introduction

nRF905 is a single chip radio transceiver for the 433/868/915MHz ISM band. The transceiver consists of a fully integrated frequency synthesizer, receiver chain with demodulator, a power amplifier, a crystal oscillator and, a modulator. The ShockBurst™ feature automatically handles preamble and CRC. You can easily configure the nRF905 through the SPI. Current consumption is very low, in transmit only 9mA at an output power of -10dBm, and in receive mode 12.5mA. Built-in power down modes makes power saving easily realizable.

2 Quick reference data

| Parameter | Value | Unit |
|--|------------|------|
| Minimum supply voltage | 1.9 | V |
| Maximum transmit output power | 10 | dBm |
| Data rate | 50 | kbps |
| Supply current in transmit @ -10dBm output power | 9 | mA |
| Supply current in receive mode | 12.5 | mA |
| Temperature range | -40 to +85 | °C |
| Typical sensitivity | -100 | dBm |
| Supply current in power down mode | 2.5 | μA |

Table 1. nRF905 quick reference data.

3 Block Diagram

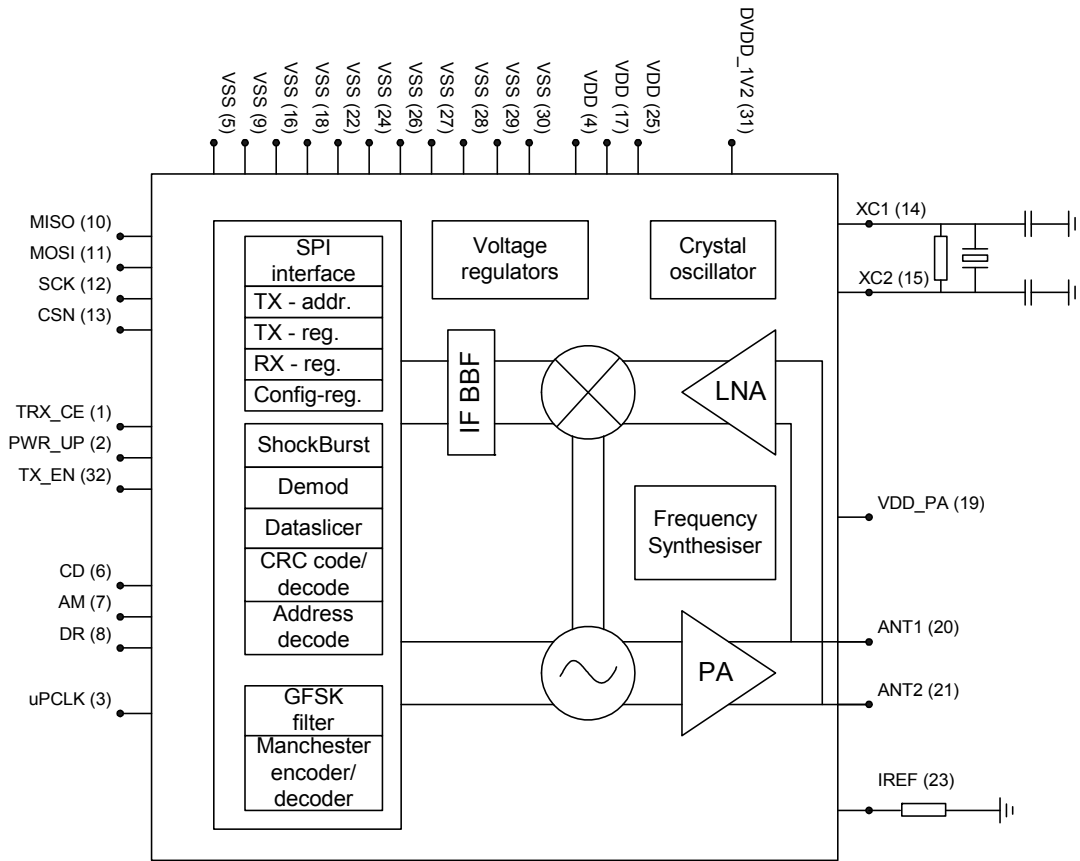

Figure 1. nRF905 with external components.

4 Absolute maximum ratings

| Operating conditions | Minimum | Maximum | Units |
|-----------------------------------|---------|----------|------------------|
| Supply voltages | | | |
| VDD | -0.3 | +3.6 | V |
| VSS | | 0 | V |
| Input voltage | | | |
| V_I | -0.3 | VDD +0.3 | V |
| Output voltage | | | |
| V_O | -0.3 | VDD +0.3 | V |
| Total power dissipation | | | |
| $P_D (T_A=85^\circ\text{C})$ | | 200 | mW |
| Temperatures | | | |
| Operating temperature | -40 | +85 | $^\circ\text{C}$ |
| Storage temperature | -40 | +125 | $^\circ\text{C}$ |
| Moisture sensitivity level | | | |
| | | 260 | $^\circ\text{C}$ |

Note: Stress exceeding one or more of the limiting values may cause permanent damage to the device.

Table 2. Absolute maximum ratings

5 Electrical Specifications

Conditions: VDD = +3V VSS = 0V, TEMP = -40°C to +85°C (typical +27°C)

| Symbol | Parameter (condition) | Notes | Min. | Typ. | Max. | Units |
|--------|-----------------------|-------|------|------|------|-------|
| VDD | Supply voltage | | 1.9 | | 3.6 | V |
| TEMP | Operating temperature | | -40 | | 85 | °C |

Table 3. Operating conditions

| Symbol | Parameter (condition) | Notes | Min. | Typ. | Max. | Units |
|-----------------|--|-------|---------|------|---------|-------|
| V _{IH} | HIGH level input voltage | | 0.7·VDD | | VDD | V |
| V _{IL} | LOW level input voltage | | VSS | | 0.3·VDD | V |
| C _i | Pin capacitance | | | | 5 | pF |
| I _{iL} | Pin leakage current | a | | | ±10 | nA |
| V _{OH} | HIGH level output voltage (I _{OH} =-0.5mA) | | VDD-0.3 | | VDD | V |
| V _{OL} | LOW level output voltage (I _{OL} =0.5mA) | | VSS | | 0.3 | V |

a. Max value determined by design and characterization testing.

Table 4. Digital input/output

| Symbol | Parameter (condition) | Notes | Min. | Typ. | Max. | Units |
|------------------------|--|-------|------|------|------|-------|
| I _{stby_eclk} | Supply current in standby, uCLK enabled | a | | 100 | | μA |
| I _{stby_dclk} | Supply current in standby, uCLK disabled | b | | 12.5 | | μA |
| I _{PD} | Supply current in power down mode | c | | 2.5 | | μA |
| I _{SPI} | Supply current in SPI programming | d | | 20 | | μA |

- a. Output frequency is 4MHz load of external clock pin is 5pF, Crystal is 4MHz.
- b. Crystal is 4MHz.
- c. Pin voltages are VSS or VDD.
- d. Chip in power down, SPI_SCK frequency is 1MHz.

Table 5. Electrical specifications

| Symbol | Parameter (condition) | Notes | Min. | Typ. | Max. | Units |
|-----------------|-------------------------------------|-------|----------|----------|----------|-------|
| f_{OP} | Operating frequency | a | 430 | | 928 | MHz |
| f_{XTAL} | Crystal frequency | b | 4 | | 20 | MHz |
| Δf | Frequency deviation | | ± 42 | ± 50 | ± 58 | kHz |
| BR | Data rate | c | | 50 | | kbps |
| f_{CH433} | Channel spacing for 433MHz band | | | 100 | | kHz |
| $f_{CH868/915}$ | Channel spacing for 868/915MHz band | | | 200 | | kHz |

- a. Operates in the 433, 868 and 915MHz ISM band.
b. The crystal frequency may be chosen from 5 different values (4, 8, 12, 16, and 20MHz).
c. Data is Manchester encoded before GFSK modulation.

Table 6. General RF conditions

| Symbol | Parameter (condition) | Notes | Min. | Typ. | Max. | Units |
|----------------|---|-------|------|------|------|-------|
| P_{RF10} | Output power 10dBm setting | a | 7 | 10 | 11 | dBm |
| P_{RF6} | Output power 6dBm setting | a | 3 | 6 | 9 | dBm |
| P_{RF-2} | Output power -2dBm setting | a | -6 | -2 | 2 | dBm |
| P_{RF-10} | Output power -10dBm setting | a | -14 | -10 | -6 | dBm |
| $P_{BW_{-16}}$ | -16dBc bandwidth for modulated carrier | b | | 173 | | kHz |
| $P_{BW_{-24}}$ | -24dBc bandwidth for modulated carrier | b | | 222 | | kHz |
| $P_{BW_{-32}}$ | -32dBc bandwidth for modulated carrier | b | | 238 | | kHz |
| $P_{BW_{-36}}$ | -36dBc bandwidth for modulated carrier | b | | 313 | | kHz |
| P_{RF1} | 1 st adjacent channel transmit power | c | | -27 | | dBc |
| P_{RF2} | 2 nd adjacent channel transmit power | c | | -54 | | dBc |
| $I_{TX10dBm}$ | Supply current @ 10dBm output power | | | 30 | | mA |
| $I_{TX-10dBm}$ | Supply current @ -10dBm output power | | | 9 | | mA |

- a. Optimum load impedance, please see peripheral RF information.
b. Data is Manchester encoded before GFSK modulation.
c. Channel width and channel spacing is 200kHz.

Table 7. Transmitter operation

| Symbol | Parameter (condition) | Notes | Min. | Typ. | Max. | Units |
|-------------|---|-------|------|------|------|-------|
| I_{RX} | Supply current in receive mode | | | 12.5 | | mA |
| RX_{SENS} | Sensitivity at 0.1%BER | | | -100 | | dBm |
| RX_{MAX} | Maximum received signal | | 0 | | | dBm |
| C/I_{CO} | C/I Co-channel | a | | 13 | | dB |
| C/I_{1ST} | 1 st adjacent channel selectivity C/I 200kHz | a | | -7 | | dB |
| C/I_{2ND} | 2 nd adjacent channel selectivity C/I 400kHz | a | | -16 | | dB |
| C/I_{+1M} | Blocking at +1MHz | a | | -40 | | dB |
| C/I_{-1M} | Blocking at -1MHz | a | | -50 | | dB |
| C/I_{-2M} | Blocking at -2MHz | a | | -63 | | dB |

| Symbol | Parameter (condition) | Notes | Min. | Typ. | Max. | Units |
|---------------------|-----------------------|-------|------|------|------|-------|
| C/I _{+5M} | Blocking at +5MHz | a | | -70 | | dB |
| C/I _{-5M} | Blocking at -5MHz | a | | -65 | | dB |
| C/I _{+10M} | Blocking at +10MHz | a | | -69 | | dB |
| C/I _{-10M} | Blocking at -10MHz | a | | -67 | | dB |
| C/I _{IM} | Image rejection | a | | -36 | | dB |

a. Channel Level +3dB over sensitivity, interfering signal a standard CW, image lies 2MHz above wanted.

Table 8. Receiver operation

6 Current Consumption

| Mode | Crystal freq. (MHz) | Output clock Freq. (MHz) | Typical current |
|--|---------------------|--------------------------|-----------------|
| Power Down | 16 | OFF | 2.5uA |
| Standby | 4 | OFF | 12uA |
| Standby | 8 | OFF | 25uA |
| Standby | 12 | OFF | 27uA |
| Standby | 16 | OFF | 32uA |
| Standby | 20 | OFF | 46uA |
| Standby | 4 | 0.5 | 110uA |
| Standby | 8 | 0.5 | 125uA |
| Standby | 12 | 0.5 | 130uA |
| Standby | 16 | 0.5 | 135uA |
| Standby | 20 | 0.5 | 150uA |
| Standby | 4 | 1 | 130uA |
| Standby | 8 | 1 | 145uA |
| Standby | 12 | 1 | 150uA |
| Standby | 16 | 1 | 155uA |
| Standby | 20 | 1 | 170uA |
| Standby | 4 | 2 | 170uA |
| Standby | 8 | 2 | 185uA |
| Standby | 12 | 2 | 190uA |
| Standby | 16 | 2 | 195uA |
| Standby | 20 | 2 | 210uA |
| Standby | 4 | 4 | 260uA |
| Standby | 8 | 4 | 275uA |
| Standby | 12 | 4 | 280uA |
| Standby | 16 | 4 | 285uA |
| Standby | 20 | 4 | 300uA |
| Rx @ 433 | 16 | OFF | 12.2mA |
| Rx @ 868/915 | 16 | OFF | 12.8mA |
| Reduced Rx | 16 | OFF | 10.5mA |
| Tx @ 10dBm | 16 | OFF | 30mA |
| Tx @ 6dBm | 16 | OFF | 20mA |
| Tx @ -2dBm | 16 | OFF | 14mA |
| Tx @ -10dBm | 16 | OFF | 9mA |
| Conditions: VDD = 3.0V, VSS = 0V, T _A = 27°C, Load capacitance of external clock = 13pF, Crystal load capacitance = 12pF | | | |

Table 9. nRF905 current consumption

7 Pin information

7.1 Pin Assignment

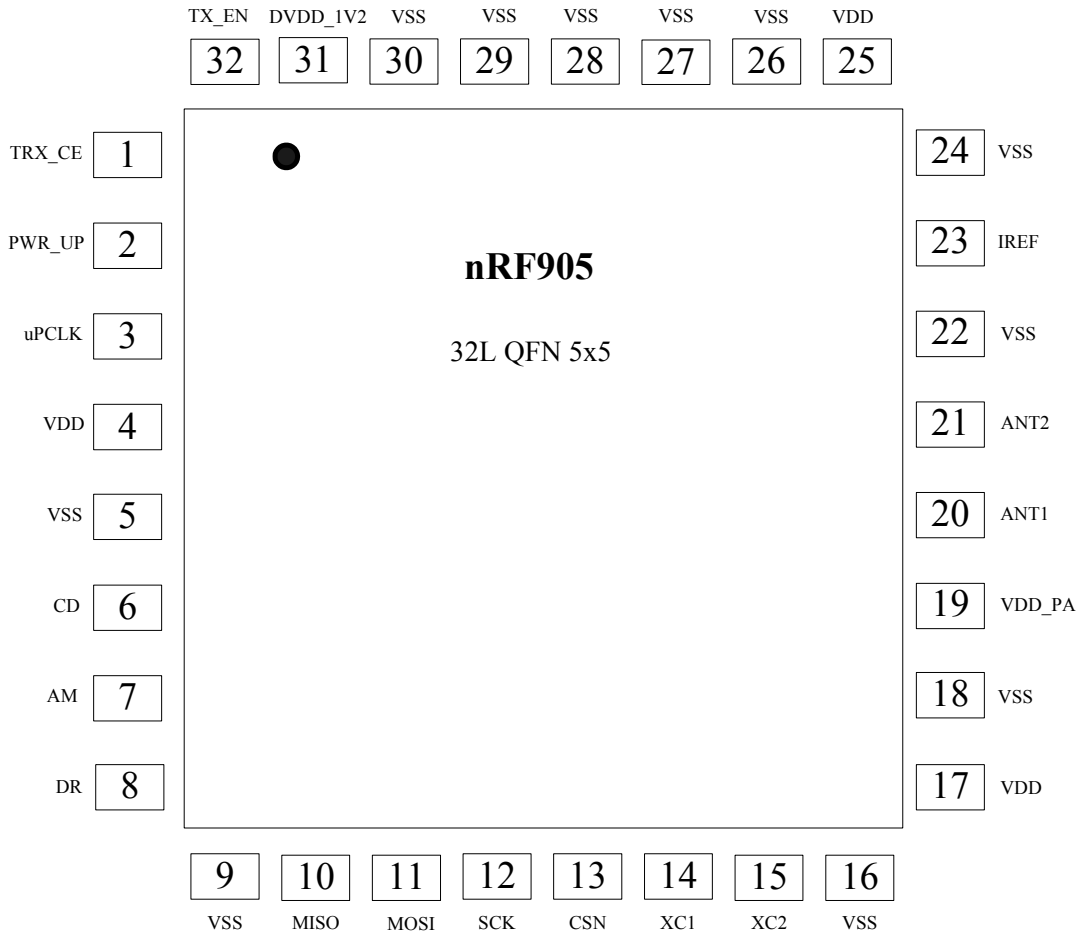

Figure 2. nRF905 pin assignment (top view) for a 32L QFN 5x5 package

7.2 Pin Functions

| Pin | Name | Pin function | Description |
|-----|----------|-----------------|---|
| 1 | TRX_CE | Digital input | Enables chip for receive and transmit |
| 2 | PWR_UP | Digital input | Power up chip |
| 3 | uPCLK | Clock output | Output clock, divided crystal oscillator full swing clock |
| 4 | VDD | Power | Power supply (+3V DC) |
| 5 | VSS | Power | Ground (0V) |
| 6 | CD | Digital output | Carrier Detect |
| 7 | AM | Digital output | Address Match |
| 8 | DR | Digital output | Receive and transmit Data Ready |
| 9 | VSS | Power | Ground (0V) |
| 10 | MISO | SPI - interface | SPI output |
| 11 | MOSI | SPI - interface | SPI input |
| 12 | SCK | SPI - Clock | SPI clock |
| 13 | CSN | SPI - enable | SPI enable, active low |
| 14 | XC1 | Analog Input | Crystal pin 1/ External clock reference pin |
| 15 | XC2 | Analog Output | Crystal pin 2 |
| 16 | VSS | Power | Ground (0V) |
| 17 | VDD | Power | Power supply (+3V DC) |
| 18 | VSS | Power | Ground |
| 19 | VDD_PA | Power output | Positive supply (1.8V) to nRF905 power amplifier |
| 20 | ANT1 | RF | Antenna interface 1 |
| 21 | ANT2 | RF | Antenna interface 2 |
| 22 | VSS | Power | Ground (0V) |
| 23 | IREF | Analog Input | Reference current |
| 24 | VSS | Power | Ground (0V) |
| 25 | VDD | Power | Power supply (+3V DC) |
| 26 | VSS | Power | Ground (0V) |
| 27 | VSS | Power | Ground (0V) |
| 28 | VSS | Power | Ground (0V) |
| 29 | VSS | Power | Ground (0V) |
| 30 | VSS | Power | Ground (0V) |
| 31 | DVDD_1V2 | Power | Low voltage positive digital supply output for decoupling |
| 32 | TX_EN | Digital input | TX_EN="1"TX mode, TX_EN="0"RX mode |

Table 10. nRF905 pin function.

8 Modes of Operation

The nRF905 has two active (RX/TX) modes and two power saving modes:

8.1 Active Modes

- ShockBurst™ RX
- ShockBurst™ TX

8.2 Power Saving Modes

- Power down and SPI programming
- Standby and SPI programming

The nRF905 mode is decided by the settings of TRX_CE, TX_EN and PWR_UP.

| PWR_UP | TRX_CE | TX_EN | Operating Mode |
|--------|--------|-------|--------------------------------|
| 0 | X | X | Power down and SPI programming |
| 1 | 0 | X | Standby and SPI programming |
| 1 | X | 0 | Read data from RX register |
| 1 | 1 | 0 | Radio Enabled - ShockBurst™ RX |
| 1 | 1 | 1 | Radio Enabled - ShockBurst™ TX |

Table 11. nRF905 operational modes.

8.3 nRF ShockBurst™ Mode

The nRF905 uses the ShockBurst™ feature. ShockBurst™ makes it possible to use the high data rate offered by the nRF905 without the need of a costly, high-speed microcontroller (MCU) for data processing/clock recovery. By placing all high speed signal processing related to RF protocol on-chip, the nRF905 offers the application microcontroller a simple SPI, the data rate is decided by the interface speed the microcontroller sets up. By allowing the digital part of the application to run at low speed, while maximizing the data rate on the RF link, the nRF905 ShockBurst™ mode reduces the average current consumption in applications. In ShockBurst™ RX, Address Match (AM) and Data Ready (DR) notifies the MCU when a valid address and payload is received respectively. In ShockBurst™ TX, the nRF905 automatically generates preamble and CRC. Data Ready (DR) notifies the MCU that the transmission is completed. This means reduced memory demand in the MCU resulting in a low cost MCU, as well as reduced software development time.

8.4 Typical ShockBurst™ TX

1. When the application MCU has data for a remote node, the address of the receiving node (TX-address) and payload data (TX-payload) are clocked into nRF905 through the SPI. The application protocol or MCU sets the speed of the interface.
2. MCU sets TRX_CE and TX_EN high, this activates a nRF905 ShockBurst™ transmission.
3. nRF905 ShockBurst™ does the following:
 - ▶ Radio is automatically powered up.
 - ▶ Data packet is completed (preamble added, CRC calculated).
 - ▶ Data packet is transmitted (50kbps).
 - ▶ Data Ready is set high when transmission is completed.

4. If AUTO_RETRAN is set high, the nRF905 continuously retransmits the packet until TRX_CE is set low.
5. When TRX_CE is set low, the nRF905 finishes transmitting the outgoing packet and then sets itself into standby mode.

If TX_EN is set low while TRX_CE is kept high, the nRF905 finishes transmitting the outgoing packet and enters RX mode in the channel already programmed in the RF-CONFIG register.

The ShockBurst™ mode ensures that a transmitted packet that has started always finishes regardless of what TRX_EN and TX_EN are set to during transmission. The new mode is activated when the transmission is completed.

For test purposes such as antenna tuning and measuring output power it is possible to set the transmitter so that a constant carrier is produced. To do this, TRX_CE must be maintained high instead of being pulsed and Auto Retransmit should be switched off. After the burst of data is sent the device continues to send the unmodulated carrier.

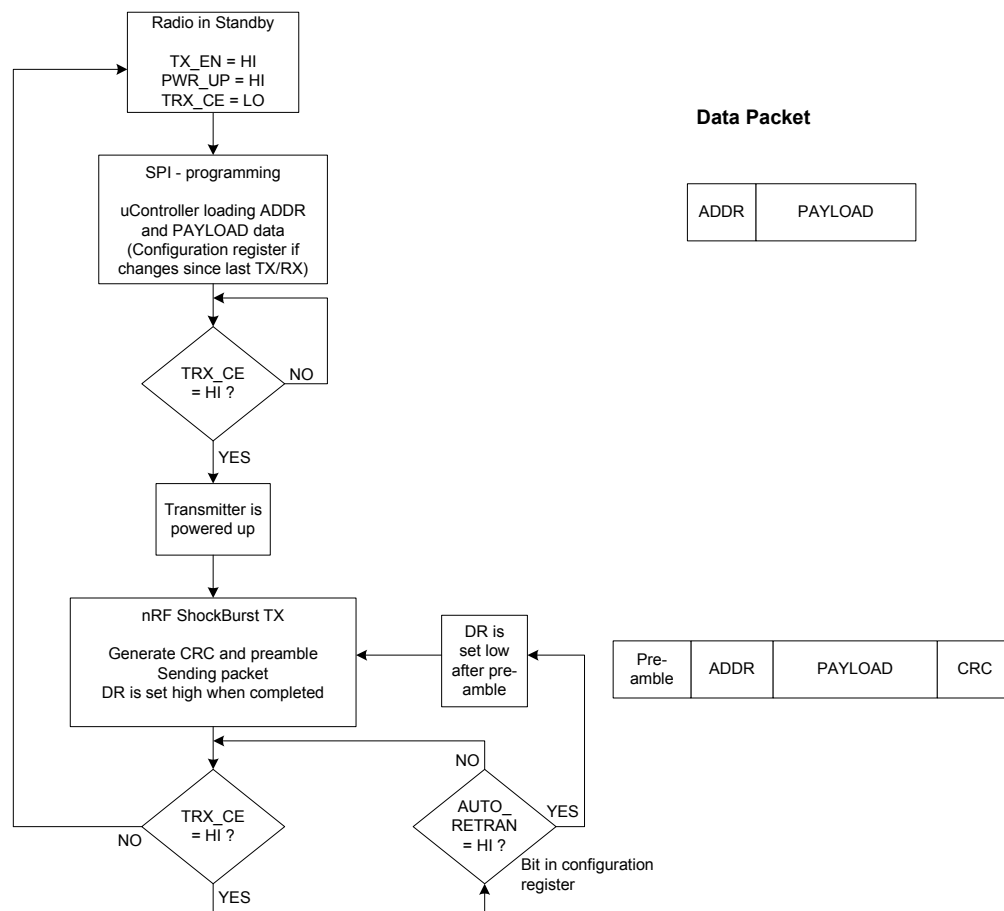

Figure 3. Flowchart ShockBurst™ transmit of nRF905.

Note: When DR is set high it can be set low again under the following conditions:

- If TX_EN is set low
- If PWR_UP is set low

8.5 Typical ShockBurst™ RX

1. ShockBurst™ RX is selected by setting TRX_CE high and TX_EN low.
2. After 650µs nRF905 is monitoring the air for incoming communication.
3. When the nRF905 senses a carrier at the receiving frequency, Carrier Detect (CD) pin is set high.
4. When a valid address is received, Address Match (AM) pin is set high.
5. When a valid packet has been received (correct CRC found), nRF905 removes the preamble, address and CRC bits, and the Data Ready (DR) pin is set high.
6. MCU sets the TRX_CE low to enter standby mode (low current mode).
7. MCU can clock out the payload data at a suitable rate through the SPI.
8. When all payload data is retrieved, nRF905 sets Data Ready (DR) and Address Match (AM) low again.
9. The chip is now ready for entering ShockBurst™ RX, ShockBurst™ TX or, power down mode.

If TX_EN is set high while TRX_CE is kept high, the nRF905 would enter ShockBurst™ TX and start a transmission according to the present contents in the SPI registers.

If TRX_CE or TX_EN is changed during an incoming packet, the nRF905 changes mode immediately and the packet is lost. However, if the MCU is sensing the Address Match (AM) pin, it knows when the chip is receiving an incoming packet and can therefore decide whether to wait for the Data Ready (DR) signal or enter a different mode.

To avoid spurious address matches it is recommended that the address length be 24 bits or higher in length. Small addresses such as 8 or 16 bits can often lead to statistical failures due to the address being repeated as part of the data packet. This can be avoided by using a longer address.

Each byte within the address should be unique. Repeating bytes within the address reduces the effectiveness of the address and increases its susceptibility to noise which increases the packet error rate. The address should also have several level shifts (that is, 10101100) reducing the statistical effect of noise and the packet error rate.

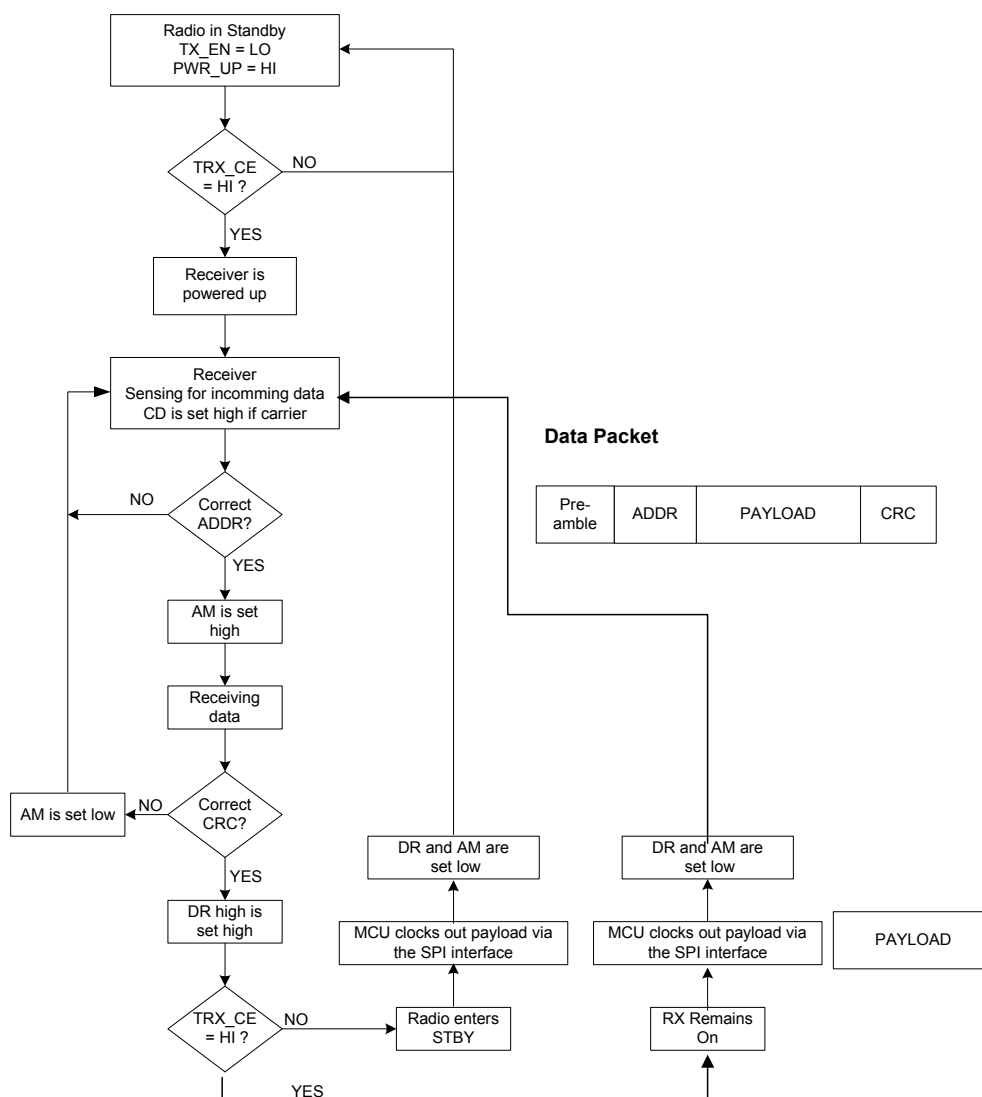

Figure 4. Flowchart ShockBurst™ receive of nRF905.

8.6 Power Down Mode

In power down the nRF905 is disabled with minimal current consumption, typically less than 2.5µA. When the device enters this mode it is not active which minimizes average current consumption and maximizes battery lifetime. The configuration word content is maintained during power down.

8.7 Standby Mode

Standby mode is used to minimize average current consumption while maintaining short start up times to ShockBurst™ RX and ShockBurst™ TX. In this mode part of the crystal oscillator is active. Current consumption is dependent on crystal frequency, Ex: I_{DD} = 12µA @4MHz and I_{DD} = 46µA @20MHz. If the uP-clock (pin 3) of nRF905 is enabled, current consumption increases and is dependent on the load capacitance and frequency. The configuration word content is maintained during standby.

9 Device Configuration

All configuration of the nRF905 is through the SPI. The interface consists of five registers. A SPI instruction set is used to decide which operation shall be performed. The SPI can be activated in any mode however, we recommend that the chip is in standby or power down mode.

9.1 SPI Register Configuration

The SPI consists of five internal registers. A register readback mode is implemented to allow verification of the register contents.

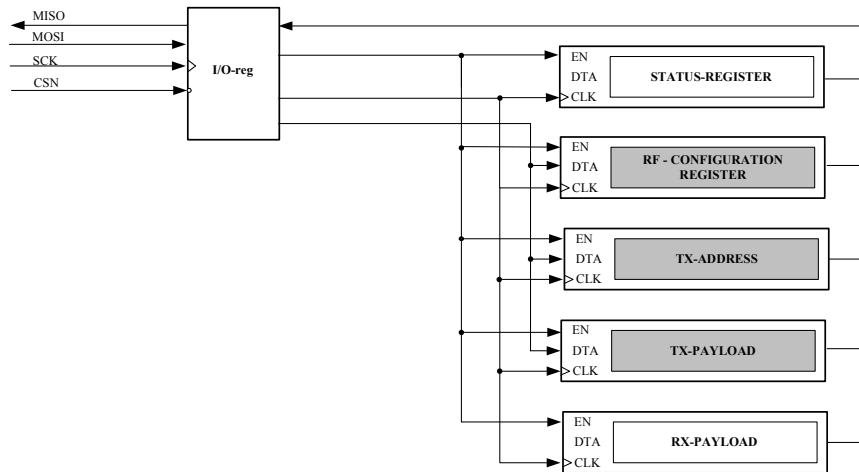

Figure 5. SPI – interface and the five internal registers.

| Internal registers | Description |
|-----------------------------|--|
| Status – Register | Register contains status of Data Ready (DR), Address Match (AM). |
| RF – Configuration Register | Register contains transceiver setup information such as frequency and output power ext. |
| TX – Address | Register contains address of target device. How many bytes used is set in the configuration register. |
| TX – Payload | Register containing the payload information to be sent in a Shock-Burst™ packet. How many bytes used is set in the configuration register. |
| RX – Payload | Register containing the payload information derived from a received valid ShockBurst™ packet. How many bytes used is set in the configuration register. Valid data in the RX-Payload register is indicated with a high Date Ready (DR) signal. |

Table 12. Internal registers description

9.2 SPI Instruction Set

The available commands used on the SPI are shown below. Whenever CSN is set low the interface expects an instruction. Every new instruction must be started by a high to low transition on CSN.

| Instruction set for the nRF905 SPI | | |
|------------------------------------|------------------------|--|
| Instruction Name | Instruction Format | Operation |
| W_CONFIG (WC) | 0000 AAAA | Write Configuration register. AAAA indicates which byte the write operation is to be started from. Number of bytes depends on start address AAAA. |
| R_CONFIG (RC) | 0001 AAAA | Read Configuration register. AAAA indicates which byte the read operation is to be started from. Number of bytes depends on start address AAAA. |
| W_TX_PAYLOAD AD (WTP) | 0010 0000 | Write TX-payload: 1 – 32 bytes. A write operation always starts at byte 0. |
| R_TX_PAYLOAD AD (RTP) | 0010 0001 | Read TX-payload: 1 – 32 bytes. A read operation always starts at byte 0. |
| W_TX_ADDRESS SS (WTA) | 0010 0010 | Write TX-address: 1 – 4 bytes. A write operation always starts at byte 0. |
| R_TX_ADDRESS SS (RTA) | 0010 0011 | Read TX-address: 1 – 4 bytes. A read operation always starts at byte 0. |
| R_RX_PAYLOAD AD (RRP) | 0010 0100 | Read RX-payload: 1 – 32 bytes. A read operation always starts at byte 0. |
| CHANNEL_CONFIGURATION (CC) | 1000 pphc cccc cccc | Special command for fast setting of CH_NO, HFREQ_PLL and PA_PWR in the CONFIGURATION REGISTER. CH_NO= cccccccc, HFREQ_PLL = h PA_PWR = pp |
| STATUS REGISTER | N.A. | The content of the status register (S[7:0]) is always read to MISO after a high to low transition on CSN as shown in Figure 6 . and Figure 7 . |

Table 13. Instruction set for the nRF905 SPI.

A read or a write operation may operate on a single byte or on a set of succeeding bytes from a given start address defined by the instruction. When accessing succeeding bytes, you read or write the MSB of the byte with the smallest byte number first.

9.3 SPI Timing

The interface supports SPI mode 0. SPI operation and timing is given in [Figure 6](#). to [Figure 8](#). and in [Table 14](#). The device must be in one of the power saving modes for you to read or write to the configuration registers.

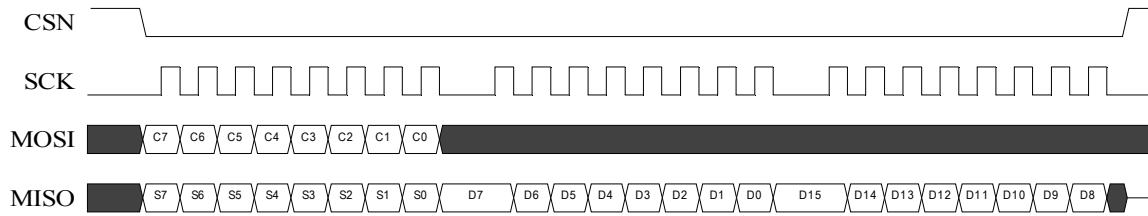

Figure 6. SPI read operation.

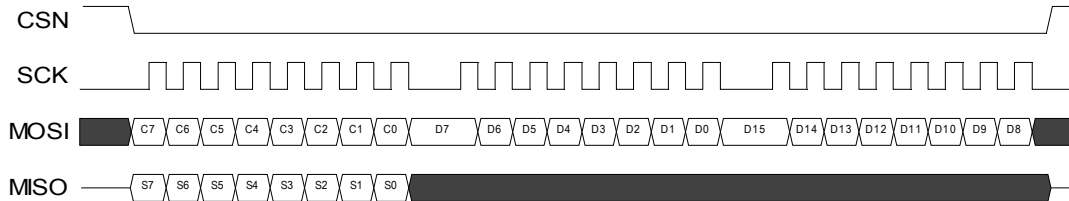

Figure 7. SPI write operation.

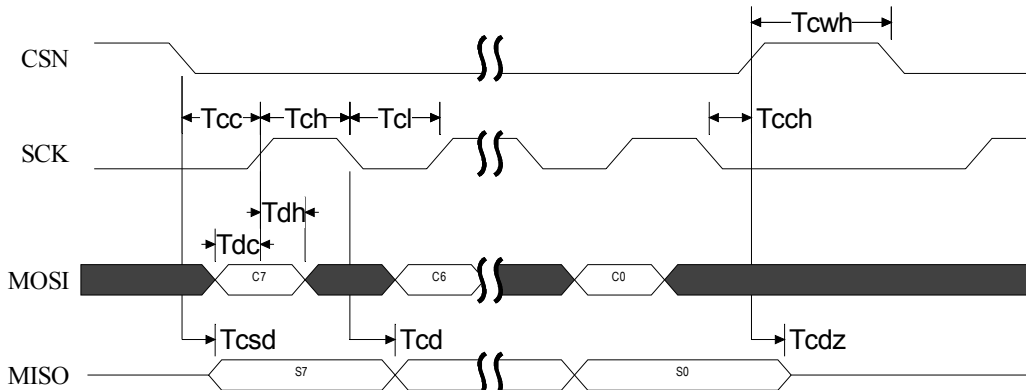

Figure 8. SPI NOP timing diagram.

| PARAMETER | SYMBOL | MIN | MAX | UNITS |
|----------------------|--------|-----|-----|-------|
| Data to SCK Setup | Tdc | 5 | | ns |
| SCK to Data Hold | Tdh | 5 | | ns |
| CSN to Data Valid | Tcsd | | 45 | ns |
| SCK to Data Valid | Tcd | | 45 | ns |
| SCK Low Time | Tcl | 40 | | ns |
| SCK High Time | Tch | 40 | | ns |
| SCK Frequency | Tsck | DC | 10 | MHz |
| SCK Rise and Fall | Tr,Tf | | 100 | ns |
| CSN to SCK Setup | Tcc | 5 | | ns |
| SCK to CSN Hold | Tcch | 5 | | ns |
| CSN Inactive time | Tcwh | 500 | | ns |
| CSN to Output High Z | Tcdz | | 45 | ns |

Table 14. SPI timing parameters ($C_{load} = 10pF$)

9.4 RF – Configuration Register Description

| Parameter | Bitwidth | Description |
|-------------|----------|--|
| CH_NO | 9 | Sets center frequency together with HFREQ_PLL (default = $001101100_b = 108_d$). $f_{RF} = (422.4 + CH_NO_d / 10) * (1 + HFREQ_PLL_d)$ MHz |
| HFREQ_PLL | 1 | Sets PLL in 433 or 868/915MHz mode (default = 0). '0' – Chip operating in 433MHz band '1' – Chip operating in 868 or 915 MHz band |
| PA_PWR | 2 | Output power (default = 00). '00' -10dBm '01' -2dBm '10' +6dBm '11' +10dBm |
| RX_RED_PWR | 1 | Reduces current in RX mode by 1.6mA. Sensitivity is reduced (default = 0). '0' – Normal operation '1' – Reduced power |
| AUTO_RETRAN | 1 | Retransmit contents in TX register if TRX_CE and TXEN are high (default = 0). '0' – No retransmission '1' – Retransmission of data packet |
| RX_AFW | 3 | RX-address width (default = 100). '001' – 1 byte RX address field width '100' – 4 byte RX address field width |
| TX_AFW | 3 | TX-address width (default = 100). '001' – 1 byte TX address field width '100' – 4 byte TX address field width |
| RX_PW | 6 | RX-payload width (default = 100000). '000001' – 1 byte RX payload field width '000010' – 2 byte RX payload field width . '100000' – 32 byte RX payload field width |
| TX_PW | 6 | TX-payload width (default = 100000). '000001' – 1 byte TX payload field width '000010' – 2 byte TX payload field width . '100000' – 32 byte TX payload field width |
| RX_ADDRESS | 32 | RX address identity. Used bytes depend on RX_AFW (default = E7E7E7E7 _h). |
| UP_CLK_FREQ | 2 | Output clock frequency (default = 11). '00' – 4MHz '01' – 2MHz '10' – 1MHz '11' – 500kHz |
| UP_CLK_EN | 1 | Output clock enable (default = 1). '0' – No external clock signal available '1' – External clock signal enabled |

| Parameter | Bitwidth | Description |
|-----------|----------|--|
| XOF | 3 | Crystal oscillator frequency. Must be set according to external crystal resonant frequency (default = 100). '000' – 4MHz '001' – 8MHz '010' – 12MHz '011' – 16MHz '100' – 20MHz |
| CRC_EN | 1 | CRC – check enable (default = 1). '0' – Disable '1' – Enable |
| CRC_MODE | 1 | CRC – mode (default = 1). '0' – 8 CRC check bit '1' – 16 CRC check bit |

Table 15. Configuration register description

9.5 Register Contents

| RF-CONFIG_REGISTER (R/W) | | |
|--------------------------|--|------------|
| Byte # | Content bit[7:0], MSB = bit[7] | Init value |
| 0 | CH_NO[7:0] | 0110_1100 |
| 1 | bit[7:6] not used, AUTO_RETRAN, RX_RED_PWR, PA_PWR[1:0], HFREQ_PLL, CH_NO[8] | 0000_0000 |
| 2 | bit[7] not used, TX_AFW[2:0], bit[3] not used, RX_AFW[2:0] | 0100_0100 |
| 3 | bit[7:6] not used, RX_PW[5:0] | 0010_0000 |
| 4 | bit[7:6] not used, TX_PW[5:0] | 0010_0000 |
| 5 | RX_ADDRESS (device identity) byte 0 | E7 |
| 6 | RX_ADDRESS (device identity) byte 1 | E7 |
| 7 | RX_ADDRESS (device identity) byte 2 | E7 |
| 8 | RX_ADDRESS (device identity) byte 3 | E7 |
| 9 | CRC_MODE, CRC_EN, XOF[2:0], UP_CLK_EN, UP_CLK_FREQ[1:0] | 1110_0111 |

Table 16. RF config register

| TX_PAYLOAD (R/W) | | |
|------------------|--------------------------------|------------|
| Byte # | Content bit[7:0], MSB = bit[7] | Init value |
| 0 | TX_PAYLOAD[7:0] | X |
| 1 | TX_PAYLOAD[15:8] | X |
| - | - | X |
| - | - | X |
| 30 | TX_PAYLOAD[247:240] | X |
| 31 | TX_PAYLOAD[255:248] | X |

Table 17. TX payload register

| TX_ADDRESS (R/W) | | |
|------------------|--------------------------------|------------|
| Byte # | Content bit[7:0], MSB = bit[7] | Init value |
| 0 | TX_ADDRESS[7:0] | E7 |
| 1 | TX_ADDRESS[15:8] | E7 |
| 2 | TX_ADDRESS[23:16] | E7 |
| 3 | TX_ADDRESS[31:24] | E7 |

Table 18. TX address register

| RX_PAYLOAD (R) | | |
|----------------|--------------------------------|------------|
| Byte # | Content bit[7:0], MSB = bit[7] | Init value |
| 0 | RX_PAYLOAD[7:0] | X |
| 1 | RX_PAYLOAD[15:8] | X |
| | - | X |
| | - | X |
| 30 | RX_PAYLOAD[247:240] | X |
| 31 | RX_PAYLOAD[255:248] | X |

Table 19. RX payload register

| STATUS_REGISTER (R) | | |
|---------------------|--|------------|
| Byte # | Content bit[7:0], MSB = bit[7] | Init value |
| 0 | AM, bit [6] not used, DR, bit [0:4] not used | X |

Table 20. Status register

The length of all registers is fixed. However, the bytes in TX_PAYLOAD, RX_PAYLOAD, TX_ADDRESS and RX_ADDRESS used in ShockBurst™ RX/TX are set in the configuration register. Register content is not lost when the device enters one of the power saving modes.

10 Important Timing Data

The following timing must be obeyed during nRF905 operation.

10.1 Device Switching Times

| nRF905 timing | Max. |
|---------------------------------|---------------------|
| PWR_DWN → ST_BY mode | 3 ms |
| STBY → TX ShockBurst™ | 650 μs |
| STBY → RX ShockBurst™ | 650 μs |
| RX ShockBurst™ → TX ShockBurst™ | 550 μs ^a |
| TX ShockBurst™ → RX ShockBurst™ | 550 μs |

a. RX to TX or TX to RX switching is available without re-programming the RF configuration register. The same frequency channel is maintained.

Table 21. Switching times for nRF905.

10.2 ShockBurst™ TX timing

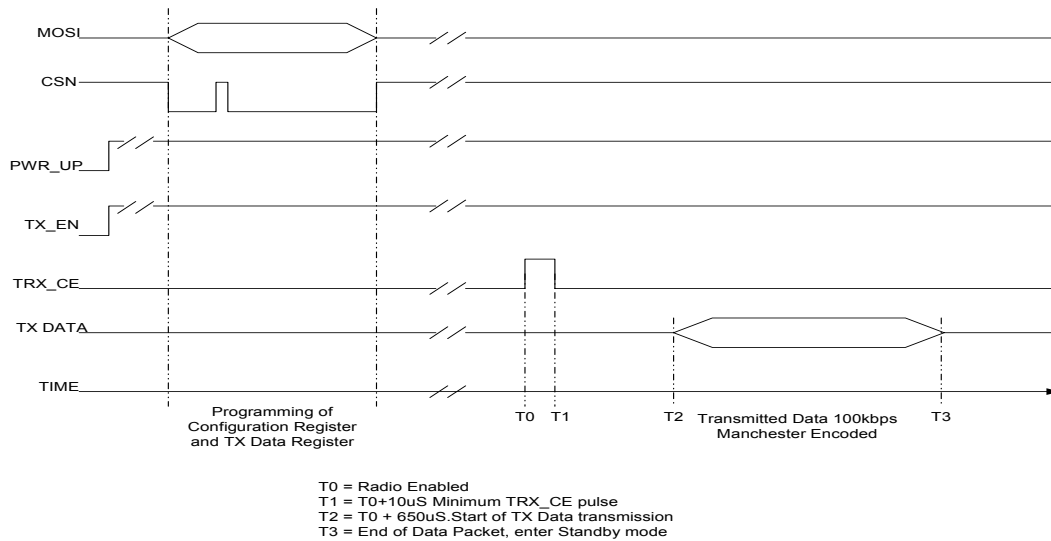

Figure 9. Timing diagram for standby to transmit

After a data packet has finished transmitting, the device automatically enters Standby mode and waits for the next pulse of TRX_CE. If the auto retransmit function is enabled the data packet continues resending the same data packet until TRX_CE is set low.

10.3 ShockBurst™ RX timing

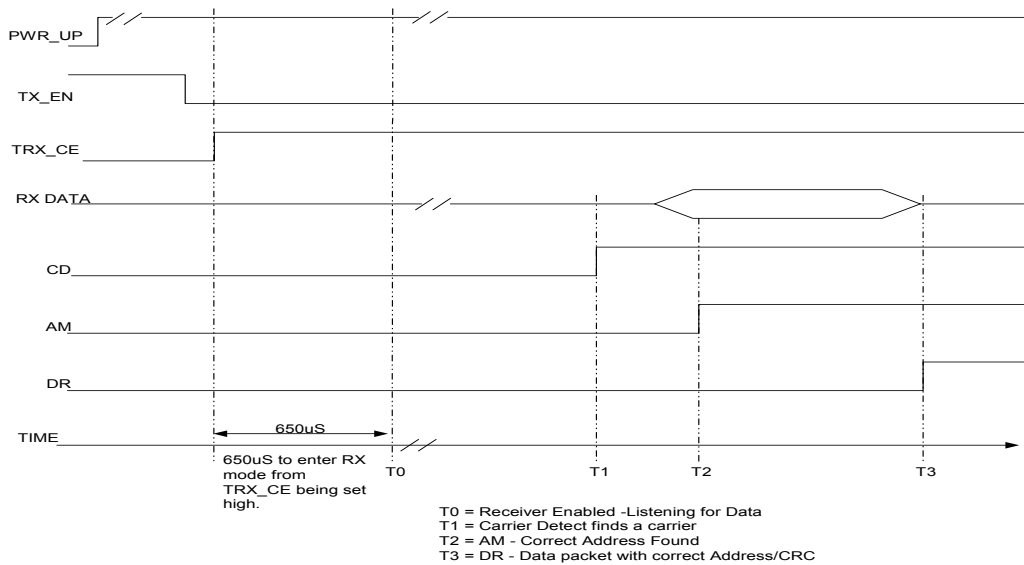

Figure 10. Timing diagram for standby to receiving

After the Data Ready (DR) has been set high a valid data packet is available in the RX data register. This may be clocked out in RX mode or standby mode. After the data has been clocked out through the SPI the Data Ready (DR) and Address Match (AM) pins are reset to low.

The RX register is reset if the PWR_UP pin is taken low or if the device is switched into TX mode, that is, TXEN is taken high. This also results in the Data Ready (DR) and Address Match (AM) pins being reset to low.

10.4 Preamble

In each data packet transmitted by the nRF905 a preamble is added automatically. The preamble is a pre-defined bit sequence used to adjust the receiver for optimal performance. A ten bit sequence is used as preamble in nRF905. The length of the preamble, $t_{preamble}$, is then 200µs.

10.5 Time On Air

The time on air is the sum of the radio start up time and the data packet length. The length of the preamble, address field, payload and CRC checksum give the data packet length while the radio start up time is given in Table 11. While preamble length and start up time are fixed the user sets the other parameters in the RF configuration register. The below equation shows how to calculate TOA:

$$TOA = t_{startup} + t_{preamble} + \frac{N_{address} + N_{payload} + N_{CRC}}{BR}$$

$t_{startup}$ and $t_{preamble}$ are RF start up time and preamble time respectively. $N_{address}$, $N_{payload}$ and N_{CRC} are numbers of bits in the address, payload and CRC checksum while BR is the bitrate, which is equal to 50kbps.

11 Peripheral RF Information

11.1 Crystal Specification

Tolerance includes initial accuracy and tolerance over temperature and aging.

| Frequency | C _L | ESR | C _{0max} | Tolerance @ 868/915 MHz | Tolerance @ 433 MHz |
|-----------|----------------|------|-------------------|-------------------------|---------------------|
| 4MHz | 8pF – 16pF | 150Ω | 7.0pF | ±30ppm | ±60ppm |
| 8MHz | 8pF – 16pF | 100Ω | 7.0pF | ±30ppm | ±60ppm |
| 12MHz | 8pF – 16pF | 100Ω | 7.0pF | ±30ppm | ±60ppm |
| 16MHz | 8pF – 16pF | 100Ω | 7.0pF | ±30ppm | ±60ppm |
| 20MHz | 8pF – 16pF | 100Ω | 7.0pF | ±30ppm | ±60ppm |

Table 22. Crystal specification of nRF905

To achieve a crystal oscillator solution with low power consumption and fast start up time, it is recommended to specify the crystal with a low value of crystal load capacitance. Specifying a lower value of crystal parallel equivalent capacitance, Co=1.5pF is also good, but this can increase the price of the crystal itself. Typically Co=1.5pF at a crystal specified for Co_max=7.0pF.

The crystal load capacitance, C_L, is given by:

$$C_L = \frac{C_1' \cdot C_2'}{C_1' + C_2'}, \quad \text{where } C_1' = C_1 + C_{PCB1} + C_{I1} \text{ and } C_2' = C_2 + C_{PCB2} + C_{I2}$$

C₁ and C₂ are 0603 SMD capacitors as shown in the application schematics. C_{PCB1} and C_{PCB2} are the layout parasitic on the circuit board. C_{I1} and C_{I2} are the capacitance seen into the XC1 and XC2 pin respectively; the value is typical 1pF.

11.2 External Clock Reference

An external reference clock, such as an MCU clock, may be used instead of a crystal. The clock signal should be applied directly to the XC1 pin, the XC2 pin can be left high impedance. When operating with an external clock instead of a crystal the clock must be applied in standby mode to achieve low current consumption. If the device is set into standby mode with no external clock or crystal then the current consumption increases up to a maximum of 1mA.

11.3 Microprocessor Output Clock

By default a microprocessor clock output is provided. Providing an output clock increases the current consumption in standby mode. The current consumption in standby depends on frequency and load of external crystal, frequency of output clock and capacitive load of the provided output clock. Typical current consumption values are found in [Table 9. on page 13](#).

11.4 Antenna Output

The ANT1 and ANT2 output pins provide a balanced RF output to the antenna. The pins must have a DC path to VDD_PA, either through a RF choke or through the center point in a dipole antenna. The load impedance seen between the ANT1/ANT2 outputs should be in the range 200-700Ω. The optimum differential load impedance at the antenna ports is given as:

900MHz225Ω+j210

430MHz300Ω+j100

A low load impedance (for instance 50Ω) can be obtained by fitting a simple matching network or a RF transformer (balun). Further information regarding balun structures and matching networks may be found in [chapter 15 on page 35](#).

11.5 Output Power Adjustment

The power amplifier in nRF905 can be programmed to four different output power settings by the configuration register. By reducing output power, the total TX current is reduced.

| Power setting | RF output power | DC current consumption |
|--|-----------------|------------------------|
| 00 | -10 dBm | 9.0 mA |
| 01 | -2 dBm | 14.0 mA |
| 10 | 6 dBm | 20.0 mA |
| 11 | 10 dBm | 30.0 mA |
| Conditions: VDD = 3.0V, VSS = 0V, T _A = 27°C, Load impedance = 400 Ω. | | |

Table 23. RF output power setting for the nRF905

11.6 Modulation

The modulation of nRF905 is Gaussian Frequency Shift Keying (GFSK) with a data rate of 100kbps. Deviation is ±50kHz. GFSK modulation results in a more bandwidth effective transmission link compared with ordinary FSK modulation.

The data is internally Manchester encoded (TX) and Manchester decoded (RX). That is, the effective symbol rate of the link is 50kbps. By using internally Manchester encoding, no scrambling in the microcontroller is needed.

11.7 Output Frequency

The operating RF frequency of nRF905 is set in the configuration register by CH_NO and HFREQ_PLL. The operating frequency is given by:

$$f_{op} = (422.4 + (CH_NO/10)) \cdot (1 + HFREQ_PLL) \text{ MHz}$$

When HFREQ_PLL is '0' the frequency resolution is 100kHz and when it is '1' the resolution is 200kHz.

The application operating frequency must be chosen to apply with the Short Range Device regulation in the area of operation.

| Operating frequency | HFREQ_PLL | CH_NO |
|---------------------|-----------|-------------|
| 430.0 MHz | [0] | [001001100] |
| 433.1 MHz | [0] | [001101011] |
| 433.2 MHz | [0] | [001101100] |
| 434.7 MHz | [0] | [001111011] |
| | | |
| 862.0 MHz | [1] | [001010110] |
| 868.2 MHz | [1] | [001110101] |
| 868.4 MHz | [1] | [001110110] |
| 869.8 MHz | [1] | [001111101] |
| | | |
| 902.2 MHz | [1] | [100011111] |
| 902.4 MHz | [1] | [100100000] |
| 927.8 MHz | [1] | [110011111] |

Table 24. Examples of real operating frequencies

11.8 PCB Layout and Decoupling Guidelines

nRF905 is an extremely robust RF device due to internal voltage regulators and requires the minimum of RF layout protocols. However, the following design rules should still be incorporated into the layout design.

A PCB with a minimum of two layers including a ground plane is recommended for optimum performance. The DC supply voltage should be decoupled as close as possible to the VDD pins with high performance RF capacitors. It is preferable to mount a large surface mount capacitor (for example, 4.7µF tantalum) in parallel with the smaller value capacitors. The supply voltage should be filtered and routed separately from the supply voltages of any digital circuitry.

Long power supply lines on the PCB should be avoided. All device grounds, VDD connections and VDD bypass capacitors must be connected as close as possible to the IC. For a PCB with a topside RF ground plane, the VSS pins should be connected directly to the ground plane. For a PCB with a bottom ground plane, the best technique is to place via holes as close as possible to the VSS pins. A minimum of one via hole should be used for each VSS pin.

Full swing digital data or control signals should not be routed close to the crystal or the power supply lines.

A fully qualified RF layout for the nRF905 and its surrounding components, including antennas and matching networks, can be downloaded from www.nordicsemi.no.

12 nRF905 features

12.1 Carrier Detect

When the nRF905 is in ShockBurst™ RX, the Carrier Detect (CD) pin is set high if a RF carrier is present at the channel the device is programmed to. This feature is very effective to avoid collision of packets from different transmitters operating at the same frequency. Whenever a device is ready to transmit it could first be set into receive mode and sense whether or not the wanted channel is available for outgoing data. This forms a very simple listen before transmit protocol. Operating Carrier Detect (CD) with Reduced RX Power mode is an extremely power efficient RF system. Typical Carrier Detect level (CD) is typically 5dB lower than sensitivity, that is, if sensitivity is -100dBm then the Carrier Detect function senses a carrier wave as low as -105dBm . Below -105dBm the Carrier Detect signal is low, that is, 0V. Above -95dBm the Carrier Detect signal is high, that is, Vdd. Between approximately -95 to -105 the Carrier Detect Signal toggles.

12.2 Address Match

When the nRF905 is in ShockBurst™ RX mode, the Address Match (AM) pin is set high as soon as an incoming packet with an address that is identical with the device's own identity is received. With the Address Match pin the controller is alerted that the nRF905 is receiving data actually before the Data Ready (DR) signal is set high. If the Data Ready (DR) pin is not set high, that is, the CRC is incorrect then the Address Match (AM) pin is reset to low at the end of the received data packet. This function can be very useful for an MCU. If Address Match (AM) is high then the MCU can make a decision to wait and see if Data Ready (DR) is set high indicating a valid data packet has been received or ignore that a possible packet is being received and switch modes.

12.3 Data Ready

The Data Ready (DR) signal makes it possible to largely reduce the complexity of the MCU software program.

In ShockBurst™ TX, the Data Ready (DR) signal is set high when a complete packet is transmitted, telling the MCU that the nRF905 is ready for new actions. It is reset to low at the start of a new packet transmission or when switched to a different mode, that is, receive mode or standby mode.

In ShockBurst™ TX Auto Retransmit the Data Ready (DR) signal is set high at the beginning of the preamble and is set low at the end of the preamble. The Data Ready (DR) signal therefore pulses at the beginning of each transmitted data packet.

In ShockBurst™ RX, the signal is set high when nRF905 has received a valid packet, that is, a valid address, packet length and correct CRC. The MCU can then retrieve the payload through the SPI. The Data Ready (DR) pin is reset to low once the data has been clocked out of the data buffer or the device is switched to transmit mode.

12.4 Auto Retransmit

One way to increase system reliability in a noisy environment or in a system without collision control is to transmit a packet several times. This is easily accomplished with the Auto Retransmit feature in nRF905. By setting the AUTO_RETRAN bit to "1" in the configuration register, the circuit keeps sending the same data packet as long as TRX_CE and TX_EN is high. As soon as TRX_CE is set low the device finishes sending the packet it is currently transmitting and then returns to standby mode.

12.5 RX Reduced Power Mode

To maximize battery lifetime in application where the nRF905 high sensitivity is not necessary; nRF905 offers a built in reduced power mode. In this mode, the receive current consumption reduces from 12.5mA to only 10.5mA. The sensitivity is reduced to typical -85dBm , $\pm 10\text{dB}$. Some degradation of the nRF905 blocking performance should be expected in this mode. The reduced power mode is an excellent option when using Carrier Detect to sense if the wanted channel is available for outgoing data.

13 Mechanical specifications

nRF905 uses the QFN 32L 5x5 green package with a mat tin finish. Dimensions are in mm. Recommended soldering reflow profile can be found in application note nAN400-08, QFN soldering reflow guidelines, www.nordicsemi.no.

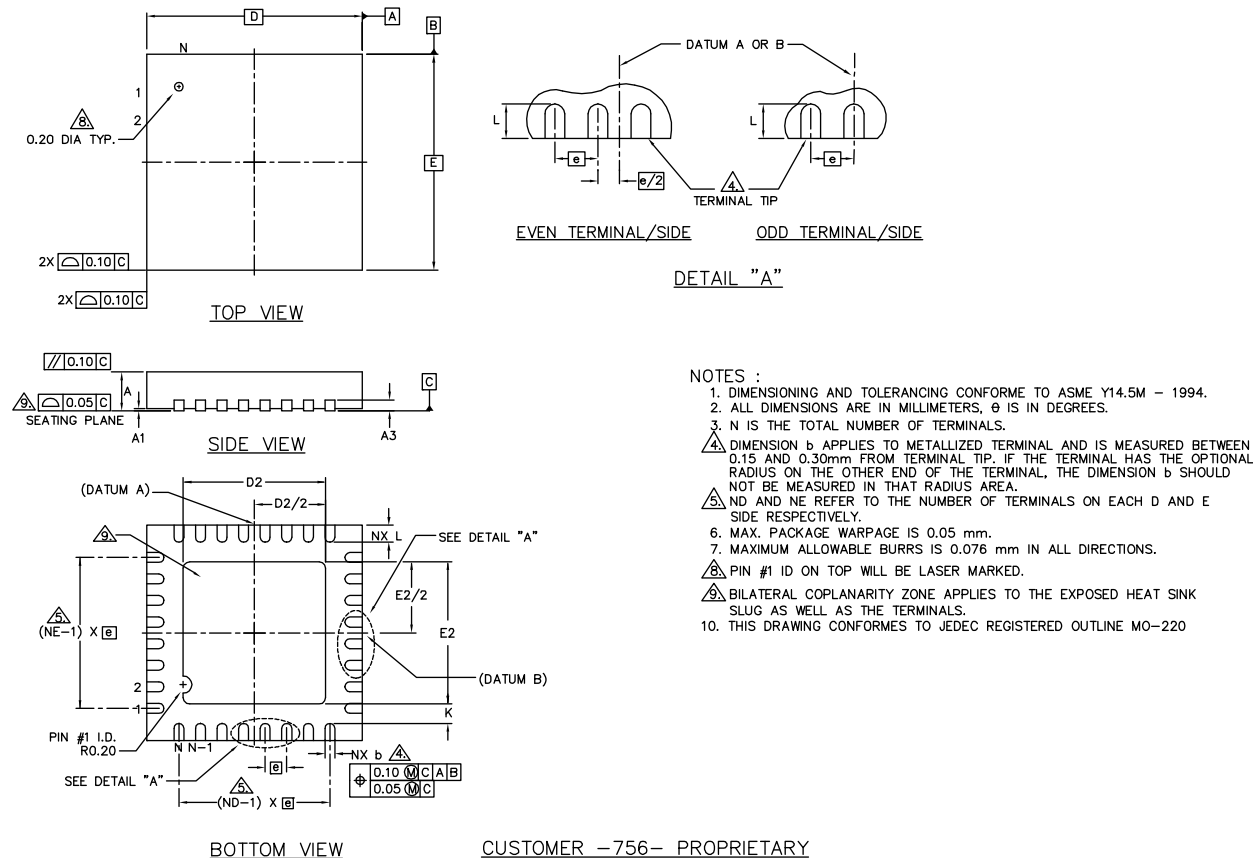

CUSTOMER -756- PROPRIETARY

| Package | | A | A1 | A3 | b | D | E | e | J | K | L | N | ND | NE | θ |
|-------------------|------|------|------|------|------|-------|-------|---------|------|-----|------|----|----|----|----------|
| QFN32 (5x5 mm) | Min. | 0.8 | 0.0 | 0.2 | 0.18 | 5 BSC | 5 BSC | 0.5 BSC | 3.2 | 0.2 | 0.35 | 32 | 8 | 8 | 0 |
| | Typ. | 0.85 | 0.02 | 0.23 | 3.3 | | | | 0.4 | 12 | | | | | |
| | Max. | 0.9 | 0.05 | 0.3 | 3.4 | | | | 0.45 | 12 | | | | | |

Figure 11. nRF905 package outline

14 Ordering information

14.1 Package marking

| | | | | | |
|---|---|---|---|---|---|
| n | R | F | | B | X |
| 9 | 0 | 5 | | | |
| Y | Y | W | W | L | L |

14.1.1 Abbreviations

| Abbreviation | Definition |
|--------------|---|
| 905 | Product number |
| B | Build Code, that is, unique code for production sites, package type and, test platform. |
| X | "X" grade, that is, Engineering Samples (optional). |
| YY | Two digit Year number |
| WW | Two digit week number |
| LL | Two letter wafer lot number code |

Table 25. Abbreviations

14.2 Product options

14.2.1 RF silicon

| Ordering code | Package | Container | MOQ ^a |
|---------------|-------------------------------------|-----------|------------------|
| nRF905 | 5x5mm 32-pin QFN, lead free (green) | Tray | 490 |
| nRF905-REEL | 5x5mm 32-pin QFN, lead free (green) | 13" reel | 2500 |

a. Minimum Order Quantity

Table 26. nRF905 RF silicon options

14.2.2 Development tools

| Type Number | Description | Version |
|----------------------|-----------------------------------|---------|
| nRF905-EVKIT 433 | nRF905 Development kit 433MHz | 1.0 |
| nRF905-EVKIT 868/915 | nRF905 Development kit 868/915MHz | 1.0 |

Table 27. nRF905 solution options

15 Application Examples

15.1 Differential Connection to a Loop Antenna

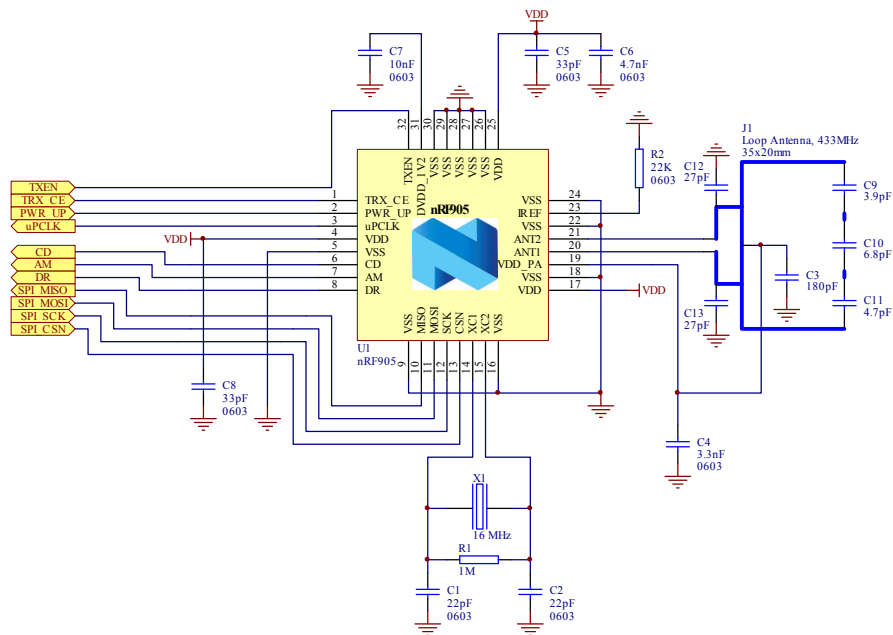

Figure 12. nRF905 Application schematic, differential connection to a loop antenna (433MHz)

| Component | Description | Size | Value | Tol. | Units |
|-----------|--|---------------------|-------|--------|-------|
| C1 | NP0 ceramic chip capacitor, (Crystal oscillator) | 0603 | 22 | ±5% | pF |
| C2 | NP0 ceramic chip capacitor, (Crystal oscillator) | 0603 | 22 | ±5% | pF |
| C3 | NP0 ceramic chip capacitor, (PA supply decoupling) | 0603 | 180 | ±5% | pF |
| C4 | X7R ceramic chip capacitor, (PA supply decoupling) | 0603 | 3.3 | ±10% | nF |
| C5 | NP0 ceramic chip capacitor, (Supply decoupling) | 0603 | 33 | ±5% | pF |
| C6 | X7R ceramic chip capacitor, (Supply decoupling) | 0603 | 4.7 | ±10% | nF |
| C7 | X7R ceramic chip capacitor, (Supply decoupling) | 0603 | 10 | ±10% | nF |
| C8 | NP0 ceramic chip capacitor, (Supply decoupling) | 0603 | 33 | ±5% | pF |
| C9 | NP0 ceramic chip capacitor, (Antenna tuning) | 0603 | 3.9 | ±0.1 | pF |
| C10 | NP0 ceramic chip capacitor, (Antenna tuning) | 0603 | 6.8 | ±0.1 | pF |
| C11 | NP0 ceramic chip capacitor, (Antenna tuning) | 0603 | 4.7 | ±0.1 | pF |
| C12 | NP0 ceramic chip capacitor, (Antenna tuning) | 0603 | 27 | ±5% | pF |
| C13 | NP0 ceramic chip capacitor, (Antenna tuning) | 0603 | 27 | ±5% | pF |
| R1 | 0.1W chip resistor, (Crystal oscillator bias) | 0603 | 1 | ±5% | MΩ |
| R2 | 0.1W chip resistor, (Reference bias) | 0603 | 22 | ±1% | kΩ |
| U1 | nRF905 Transceiver | QFN32L/5x5 | | | |
| X1 | Crystal, $C_L = 12\text{pF}$ | LxWxH = 4.0x2.5x0.8 | 16 | ±60ppm | MHz |

Table 28. Recommended external components, differential connection to a loop antenna (433MHz)

15.2 PCB Layout Example; Differential Connection to a Loop Antenna

Figure 13. shows a PCB layout example for the application schematic in **Figure 12.** A double sided FR-4 board of 1.6mm thickness is used. This PCB has a ground plane on the bottom layer. Additionally, there are ground areas on the component side of the board to ensure sufficient grounding of critical components. A large number of via holes connect the top layer ground areas to the bottom layer ground plane. There is no ground plane beneath the antenna.

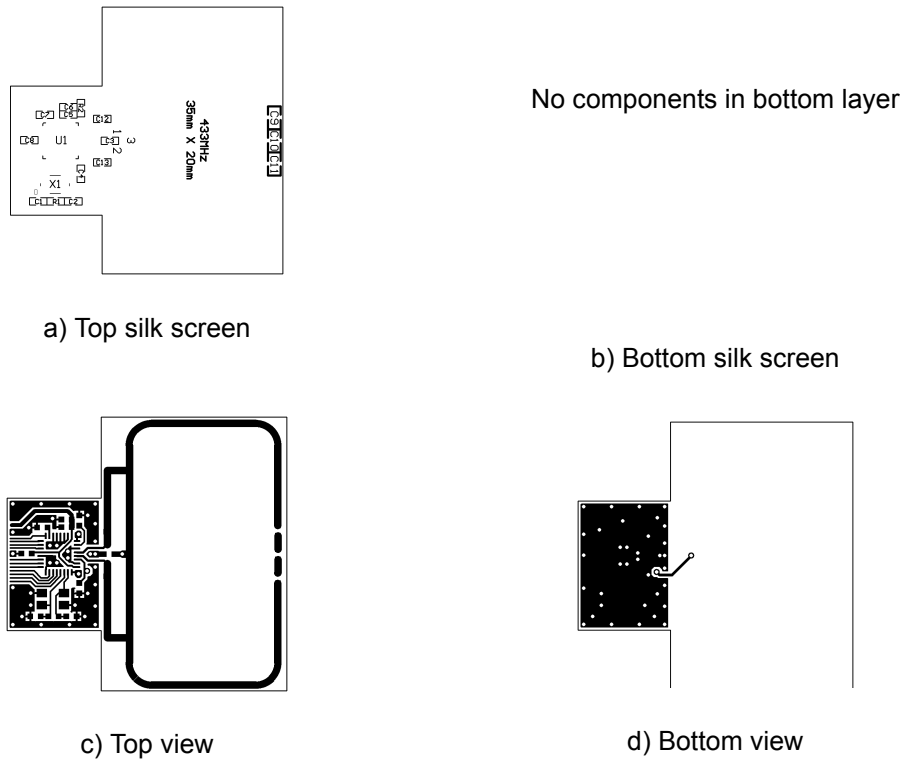

Figure 13. PCB layout example for nRF905, differential connection to a loop antenna

A fully qualified RF layout for the nRF905 and its surrounding components, including antennas and matching networks, can be downloaded from www.nordicsemi.no.

15.3 Single ended connection to 50Ω antenna

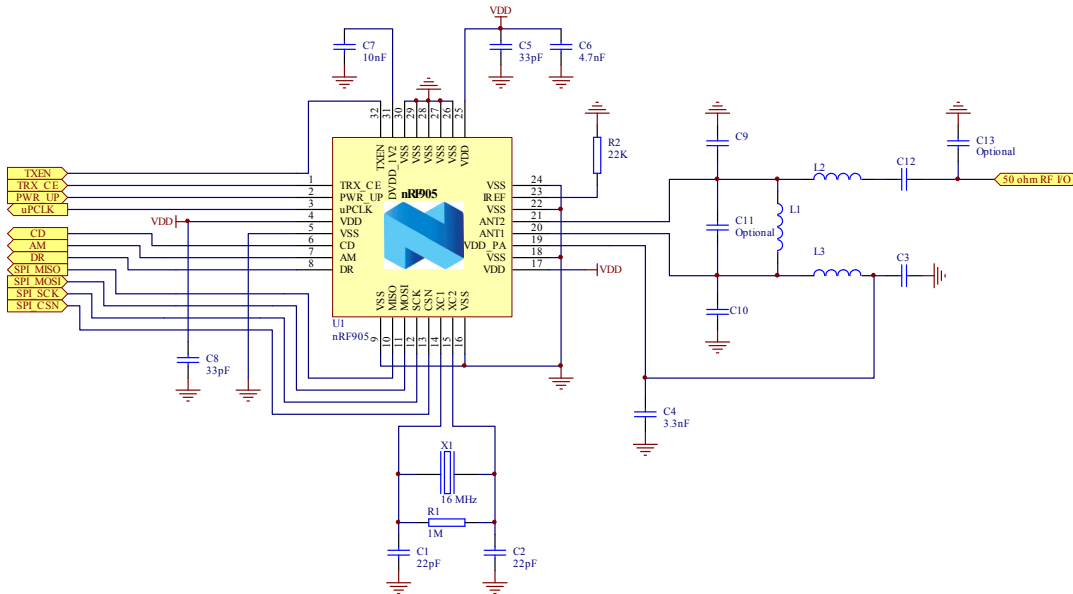

Figure 14. 433 MHz operating nRF905 application schematic, single ended connection to 50Ω antenna by using a differential to single ended matching network

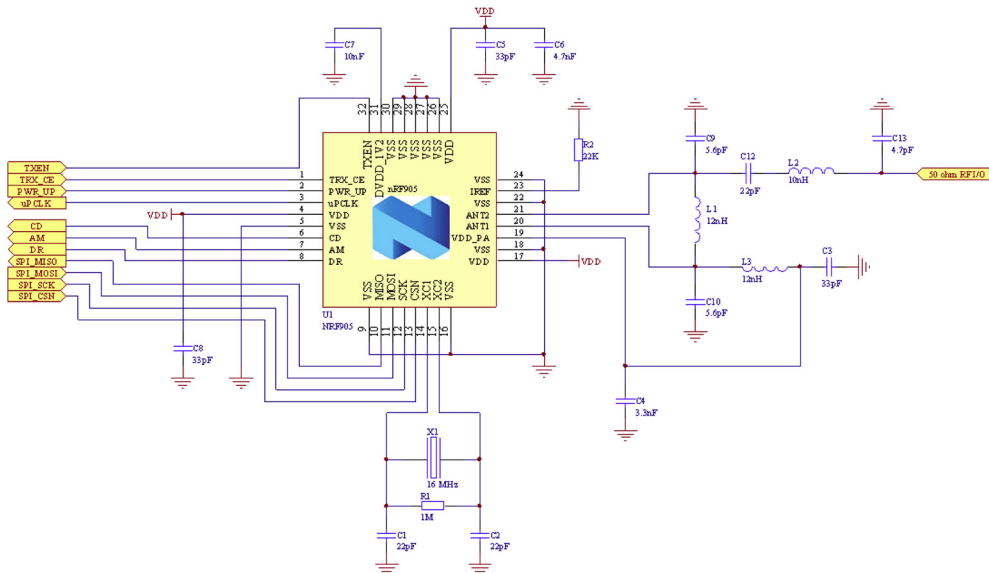

Figure 15. 868-915 MHz operating nRF905 application schematic, single ended connection to 50Ω antenna by using a differential to single ended matching network

| Component | Description | Size | Value | Tol. | Units |
|-----------|--|------|--------------------------|-----------------------------|-------|
| C1 | NP0 ceramic chip capacitor, (Crystal oscillator) | 0603 | 22 | ±5% | pF |
| C2 | NP0 ceramic chip capacitor, (Crystal oscillator) | 0603 | 22 | ±5% | pF |
| C3 | NP0 ceramic chip capacitor, (PA supply decoupling) @ 433MHz @ 868MHz @ 915MHz | 0603 | 180 33 33 | ±5% | pF |
| C4 | X7R ceramic chip capacitor, (PA supply decoupling) | 0603 | 3.3 | ±10% | nF |
| C5 | NP0 ceramic chip capacitor, (Supply decoupling) | 0603 | 33 | ±5% | pF |
| C6 | X7R ceramic chip capacitor, (Supply decoupling) | 0603 | 4.7 | ±10% | nF |
| C7 | X7R ceramic chip capacitor, (Supply decoupling) | 0603 | 10 | ±10% | nF |
| C8 | NP0 ceramic chip capacitor, (Supply decoupling) | 0603 | 33 | ±5% | pF |
| C9 | NP0 ceramic chip capacitor, (Impedance matching) @ 433MHz @ 868MHz @ 915MHz | 0603 | 18 5.6 5.6 | ±5% <±0.25pF <±0.25pF | pF |
| C10 | NP0 ceramic chip capacitor, (Impedance matching) @ 433MHz @ 868MHz @ 915MHz | 0603 | 18 5.6 5.6 | ±5% <±0.25pF <±0.25pF | pF |
| C11 | NP0 ceramic chip capacitor, (Impedance matching) | 0603 | Not fitted | | pF |
| C12 | NP0 ceramic chip capacitor, (Impedance matching) @ 433MHz @ 868MHz @ 915MHz | 0603 | 6.8 22 22 | ±5% ±5% ±5% | pF |
| C13 | NP0 ceramic chip capacitor, (Impedance matching) @ 433MHz @ 868MHz @ 915MHz | 0603 | Not fitted 4.7 4.7 | | pF |
| L1 | Chip inductor, (Impedance matching) @ 433MHz: SRF> 433MHz @ 868MHz: SRF> 868MHz @ 915MHz: SRF> 915MHz | 0603 | 12 12 12 | ±5% | nH |
| L2 | Chip inductor, (Impedance matching) @ 433MHz: SRF> 433MHz @ 868MHz: SRF> 868MHz @ 915MHz: SRF> 915MHz | 0603 | 39 10 10 | ±5% ±5% ±5% | nH |

| Component | Description | Size | Value | Tol. | Units |
|-----------|--|------------------------|----------------|----------------------------|-------|
| L3 | Chip inductor, (Impedance matching) @ 433MHz: SRF> 433MHz @ 868MHz: SRF> 868MHz @ 915MHz: SRF> 915MHz | 0603 | 39 12 12 | ±5% ±5% ±5% | nH |
| R1 | 0.1W chip resistor, (Crystal oscillator bias) | 0603 | 1 | ±5% | MΩ |
| R2 | 0.1W chip resistor, (Reference bias) | 0603 | 22 | ±1% | kΩ |
| U1 | nRF905 Transceiver | QFN32L/5x5 | | | |
| X1 | Crystal, $C_L = 12\text{pF}$ @ 433MHz @ 868MHz @ 915MHz | LxWxH = 4.0x2.5x0.8 | 16 | ±60ppm ±30ppm ±30ppm | MHz |

Table 29. Recommended external components, single ended connection to 50Ω antenna

15.4 PCB Layout Example; Single Ended Connection to 50Ω Antenna

Figure 16. shows a PCB layout example for the application schematic in Figure 14. and Figure 17. shows a PCB layout example for the application schematic in Figure 15. A double sided FR-4 board of 1.6mm thickness is used. This PCB has a ground plane on the bottom layer. Additionally, there are ground areas on the component side of the board to ensure sufficient grounding of critical components. A large number of via holes connect the top layer ground areas to the bottom layer ground plane.

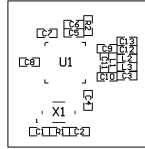

No components in bottom layer

a) Top silk screen

b) Bottom silk screen

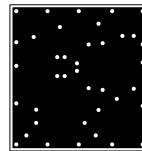
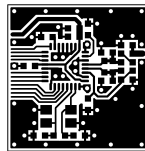

c) Top view

d) Bottom view

Figure 16. PCB layout example for 433 MHz operation on nRF905, single ended connection to 50Ω antenna by using a differential to single ended matching network

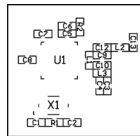

No components in bottom layer

b) Bottom silk screen

a) Top silk screen

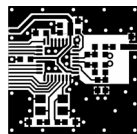

c) Top view

d) Bottom view

Figure 17. PCB layout example for 868-915 MHz operation on nRF905, single ended connection to 50Ω antenna by using a differential to single ended matching network

A fully qualified RF layout for the nRF905 and its surrounding components, including antennas and matching networks, can be downloaded from www.nordicsemi.no

16 Glossary of terms

| Term | Description |
|---------|---------------------------------|
| ADC | Analog to Digital Converter |
| AM | Address Match |
| CD | Carrier Detect |
| CLK | Clock |
| CRC | Cyclic Redundancy Check |
| DR | Data Ready |
| GFSK | Gaussian Frequency Shift Keying |
| ISM | Industrial-Scientific-Medical |
| kSPS | kilo Samples per Second |
| MCU | Micro Controller Unit |
| PWR_DWN | Power Down |
| PWR_UP | Power Up |
| RX | Receive |
| SPI | Serial Programmable Interface |
| CSN | SPI Chip Select Not |
| MISO | SPI Master In Slave Out |
| MOSI | SPI Master Out Slave In |
| SCK | SPI Serial Clock |
| SPS | Samples per Second |
| STBY | Standby |
| TRX_EN | Transmit/Receive Enable |
| TX | Transmit |
| TX_EN | Transmit Enable |

Table 30. Glossary of terms.

Компания «Океан Электроники» предлагает заключение долгосрочных отношений при поставках импортных электронных компонентов на взаимовыгодных условиях!

Наши преимущества:

- Поставка оригинальных импортных электронных компонентов напрямую с производств Америки, Европы и Азии, а так же с крупнейших складов мира;
- Широкая линейка поставок активных и пассивных импортных электронных компонентов (более 30 млн. наименований);
- Поставка сложных, дефицитных, либо снятых с производства позиций;
- Оперативные сроки поставки под заказ (от 5 рабочих дней);
- Экспресс доставка в любую точку России;
- Помощь Конструкторского Отдела и консультации квалифицированных инженеров;
- Техническая поддержка проекта, помощь в подборе аналогов, поставка прототипов;
- Поставка электронных компонентов под контролем ВП;
- Система менеджмента качества сертифицирована по Международному стандарту ISO 9001;
- При необходимости вся продукция военного и аэрокосмического назначения проходит испытания и сертификацию в лаборатории (по согласованию с заказчиком);
- Поставка специализированных компонентов военного и аэрокосмического уровня качества (Xilinx, Altera, Analog Devices, Intersil, Interpoint, Microsemi, Actel, Aeroflex, Peregrine, VPT, Syfer, Eurofarad, Texas Instruments, MS Kennedy, Miteq, Cobham, E2V, MA-COM, Hittite, Mini-Circuits, General Dynamics и др.);

Компания «Океан Электроники» является официальным дистрибьютором и эксклюзивным представителем в России одного из крупнейших производителей разъемов военного и аэрокосмического назначения «**JONHON**», а так же официальным дистрибьютором и эксклюзивным представителем в России производителя высокотехнологичных и надежных решений для передачи СВЧ сигналов «**FORSTAR**».



JONHON

«**JONHON**» (основан в 1970 г.)

Разъемы специального, военного и аэрокосмического назначения:

(Применяются в военной, авиационной, аэрокосмической, морской, железнодорожной, горно- и нефтедобывающей отраслях промышленности)

«**FORSTAR**» (основан в 1998 г.)

ВЧ соединители, коаксиальные кабели,
кабельные сборки и микроволновые компоненты:

(Применяются в телекоммуникациях гражданского и специального назначения, в средствах связи, РЛС, а так же военной, авиационной и аэрокосмической отраслях промышленности).



Телефон: 8 (812) 309-75-97 (многоканальный)

Факс: 8 (812) 320-03-32

Электронная почта: ocean@oceanchips.ru

Web: <http://oceanchips.ru/>

Адрес: 198099, г. Санкт-Петербург, ул. Калинина, д. 2, корп. 4, лит. А